

# SIDE STEP

————— User Manual —————

2018-2022 Wrangler JL 4 Door



Model:	NJL02C108
Material:	Q235A
Product Dimensions:	64.64 x 7.68 x 5.32 inch
Package Dimensions:	40.15 x 16.68 x 9.84 inch
Product Weight:	49.82 lbs

---

※Thank you for purchasing the SIDE STEP. Please read this manual carefully and keep it properly if you need to refer to it afterward. If you need any support or assistance, please contact us with your product model number and order number, and our support team will help you solve problems.

**⚠ WARNING**





※ This product is designed primarily to enhance the appearance of the vehicle. Do not rely in any way on the components of this product to protect against injury or death in the event of an accident. To reduce the risk of serious injury or property damage, please read all safety messages and understand all instructions and procedure notices before attempting to install or use this product.

**⚠ CAUTION**







※ Properly torque and recheck fasteners and security of step tread after 250 miles and inspect frequently. Do not use if damaged.

※ Side Steps are heavy, and we strongly suggest the assistance of an able-bodied assistant during the lifting and installation of your Side Step.

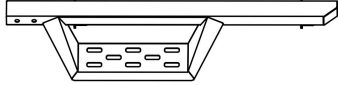
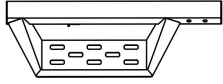
# REQUIRED TOOLS

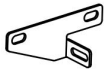
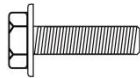
<p>Socket</p> 	<p>Ratchet</p> 	<p>Wrench</p> 	<p>Safety Glasses</p> 
---	--	--	---

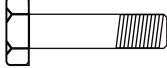
## Parts Information

Parts NO.	Parts Name	Size	Line Graph	Qty	Color
/	Front Side Step	/		2	Black
/	Rear Side Step	/		2	Black
/	Connector	/		2	Black
/	Basket	/		6	Black
/	Support Basket	/		6	Black
B42	Hex Flange Bolts	M8x25-8.8		37	Blue Zinc Plating
W31	Flat Washer	Φ8x24x2		37	Blue Zinc Plating
N25	Hex Flange Nuts	M8		31	Blue Zinc Plating
B54	Hex Bolts	M10x80-8.8		9	Dacro Black
N17	Hex Flange Nuts	M10		9	Dacro Black

**\*Note: spare parts such as B42, W31, N25, B54, and N17 are provided with 1PCS each (included in the number of parts details).**

# Installation Instructions

※**Note:** This installation manual takes a single side as a sample, please repeat the steps for the other side.

**Step 1:** Before installing the pedal, ensure that after installation, the height of the pedal from the ground is greater than the original height of the bottom of the car (as shown in the figure).

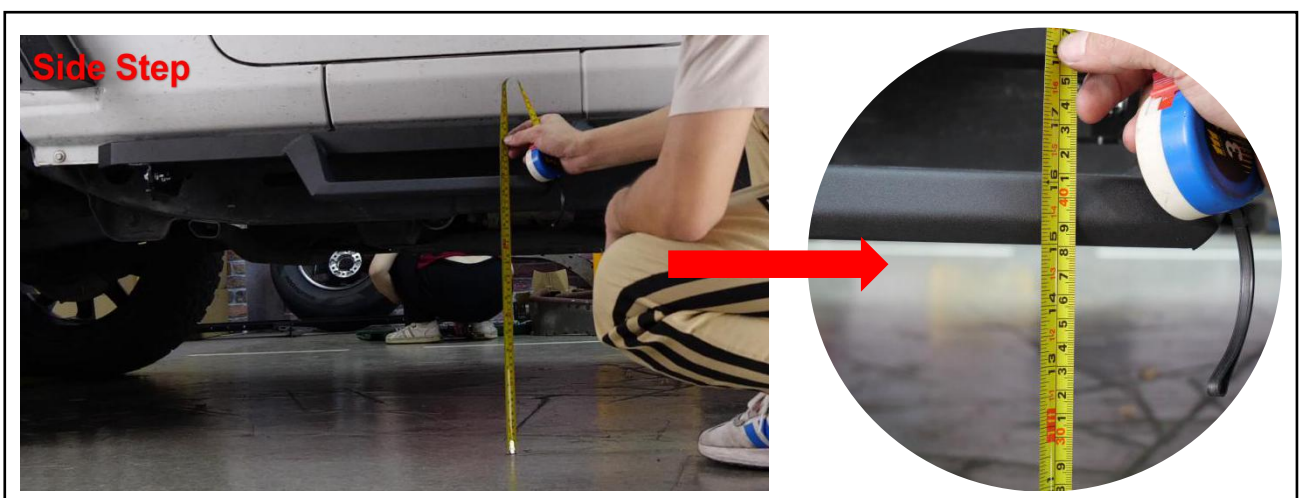
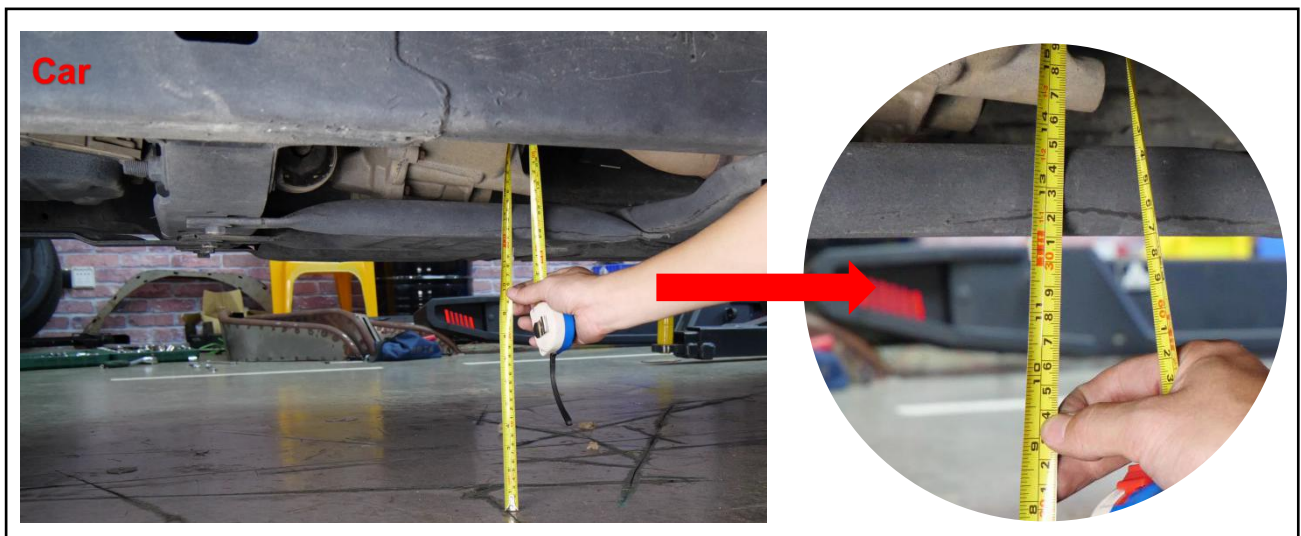

**Step 2:** Open the carton and take out the parts. Check whether the number of components is complete.

### Step 3: Splice the Side Step.

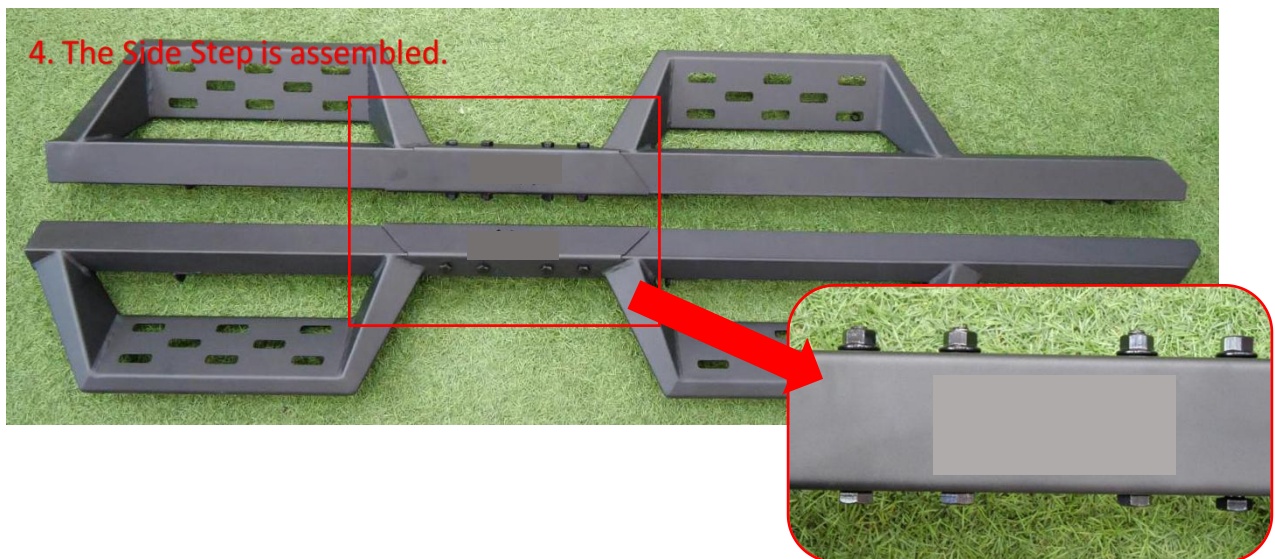
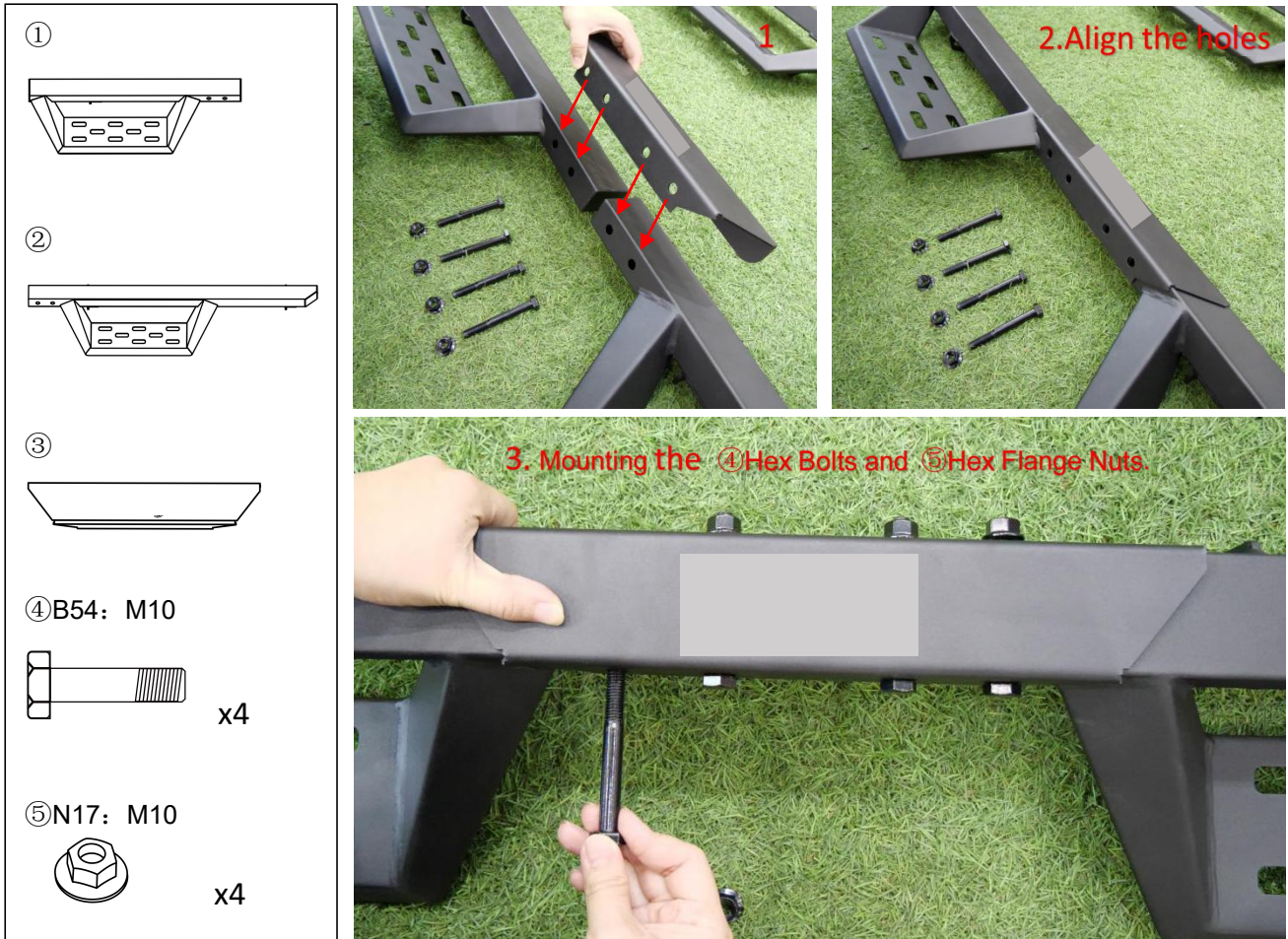

**NOTICE:** Before installing the Side Step on to the car, please ensure that the connecting bolts on the Side Step are all tightened.

**Step 4:** Remove the original side skirt and clean the surface of the rocker panel to ensure it is free of dust, dirt, and debris.



**Step 5:** Mount the Basket and Support Basket.

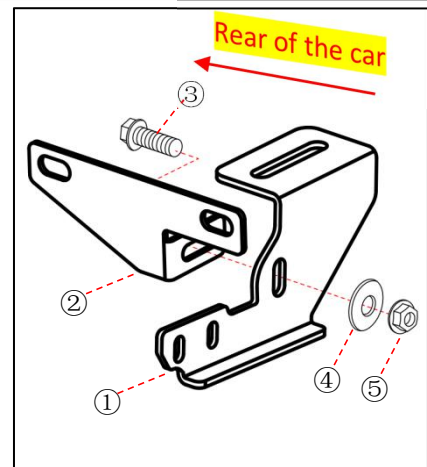
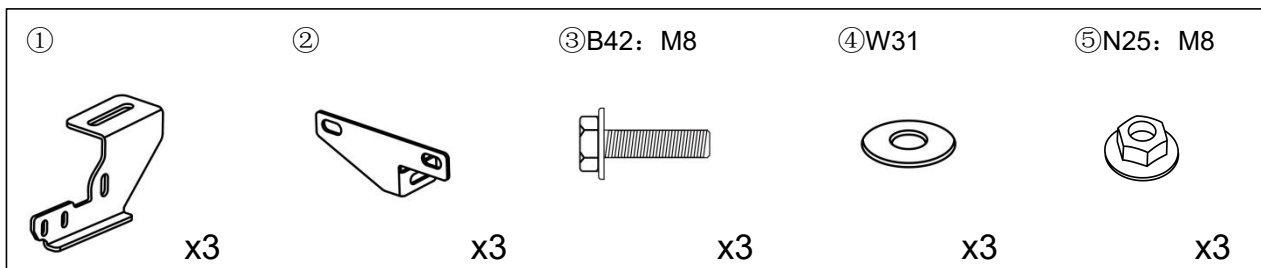

**NOTICE:** Pay attention to the right and left sides of the bracket and Support Basket. Do not tighten the screw.

**Step 6:** Install the Bracket and Support Basket onto the car body.

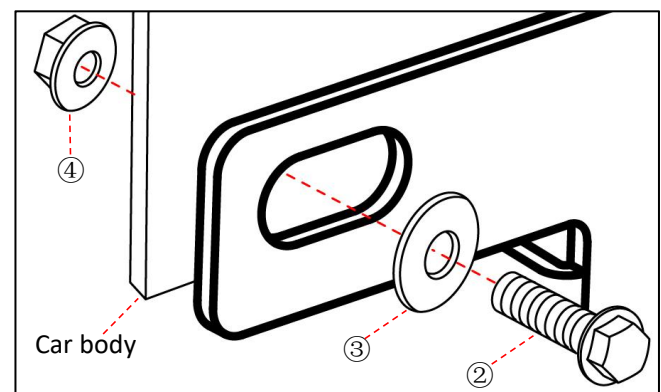
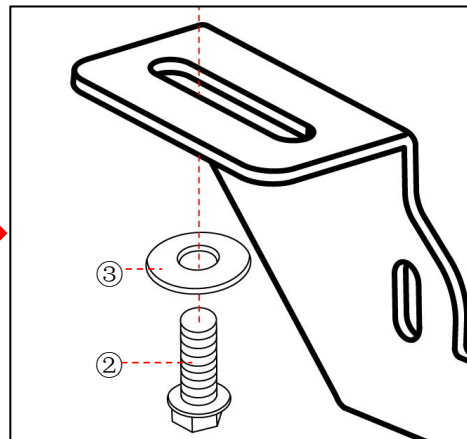
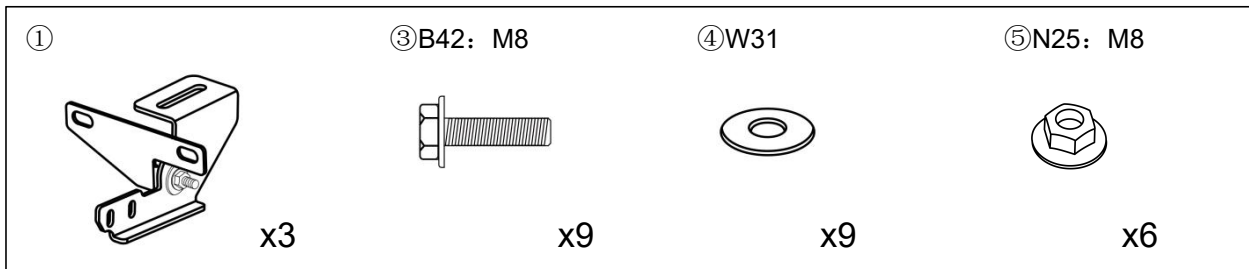

**NOTICE:** Do not tighten the screw in this step.



**Step 7:** Tighten the bolts fixed between the Support Basket and the car body.



**Step 8:** Install the entire Side Step.

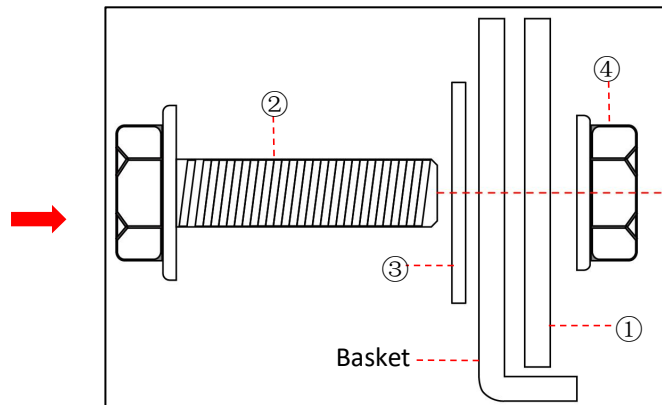
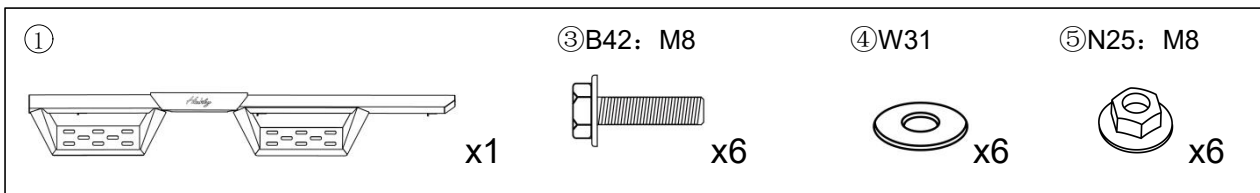



**NOTICE:** Do not tighten the screw in this step.



**Step 9:** Adjust the balance of the Side Step and the car side, and tighten the corresponding bolts.

**Tips:** Stretch your hands into the gap between the Side Step and the side of the car (one finger width or so) to adjust the distance.



**Step 10:** Adjust the balance of the pedal to the ground and tighten the corresponding bolts.

**Tips:** Use a stretch ruler to measure and balance the left and right sides of the pedal. Please ensure that the pedal has the same distance to the ground on both sides.

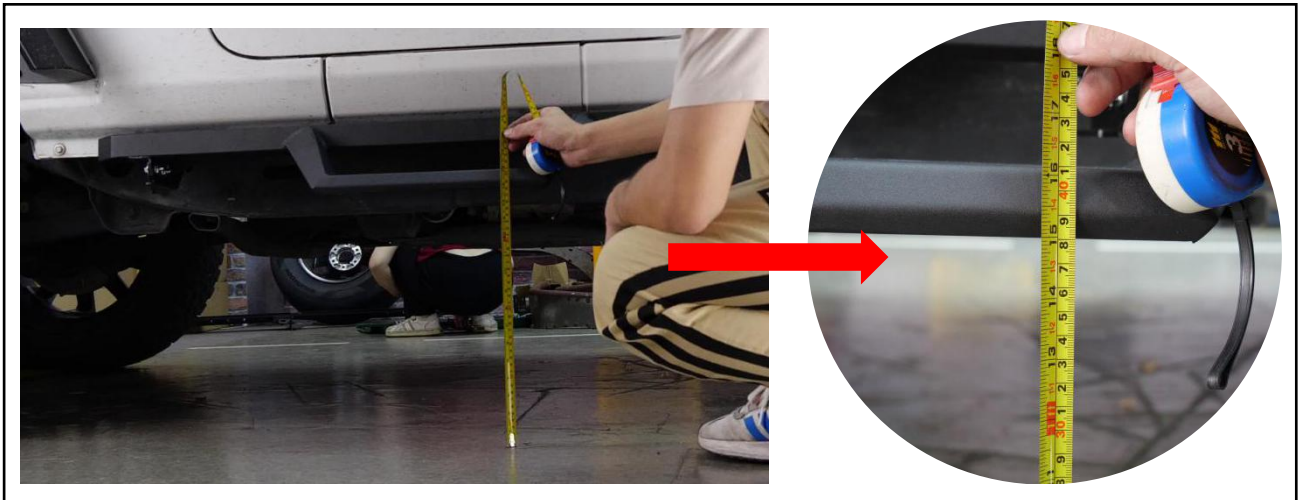

**Step 11:** Installation of a Side Step is complete. Please do periodic inspections of the Side Step to make sure that all hardware is secure and tight.