

# SIDE STEP

— User Manual —

2007-2018 Jeep Wrangler JK 4 Doors



Model:	NJK02C107
Material:	Q235A
Product Dimensions:	65.8 x 8.1 x 5.6 inch
Package Dimensions:	41.7x 19.6 x 9.8 inch
Product Weight:	48 lbs

---

※ Thank you for purchasing the SIDE STEP. Please read this manual carefully and keep it properly if you need to refer to it afterward. If you need any support or assistance, please contact us with your product model number and order number, and our support team will help you solve problems.



**⚠ WARNING**

※ This product is designed primarily to enhance the appearance of the vehicle. Do not rely in any way on the components of this product to protect against injury or death in the event of an accident. To reduce the risk of serious injury or property damage, please read all safety messages and understand all instructions and procedure notices before attempting to install or use this product.





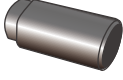

**⚠ CAUTION**

※ Properly torque and recheck fasteners and security of step tread after 250 miles and inspect frequently. Do not use if damaged.

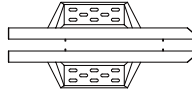
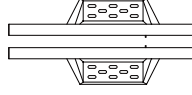
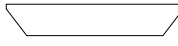
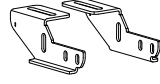
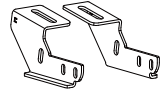
# REQUIRED TOOLS

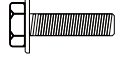
Socket 	Ratchet 	Safety Glasses 
---	--	---

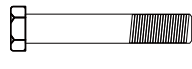
## Parts Information

NO.	Parts Name	Size	Line Graph	Qty	Color
/	Front Side Step L/R	/		1	Black
/	Rear Side Step L/R	/		1	Black
/	Connectors	/		2	Black
/	Front & Mid Barkecks L & R	/		2	Black
/	Rear Barkecks L & R	/		1	Black
/	Support Barkecks	/		3	Black
B42	Hex Flange Bolts	M8x25		37	Blue Zinc Plating
W31	Flat Washer	Φ8x24x2		37	Blue Zinc Plating
N25	Hex Flange Nuts	M8		31	Blue Zinc Plating
B54	Hex Bolts	M10x80		9	Black
N17	Hex Flange Nuts	M10		9	Black



**\*Note: spare parts such as B42, W31, N25, B54, and N17 are provided with 1PCS each (included in the number of parts details).**

# Installation Instructions

※ **Note:** This installation manual takes a single side as a sample, please repeat the steps for the other side.

**Step 1:** Open the carton and take out the parts. Check whether the number of components is complete.

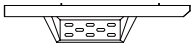
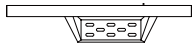
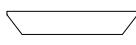
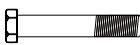
**Step 2:** Splice the Side Step.

①Front Side Step  x1	②Rear Side Step  x1	②Connectors  x1	④B54: M10x80  x4	⑤N17: M10  x4
---	--	--	---	--



**NOTICE:** Before installing the Side Step on to the car, please ensure that the connecting bolts on the Side Step are all tightened.

### Step 3: Splicing the Bumper.

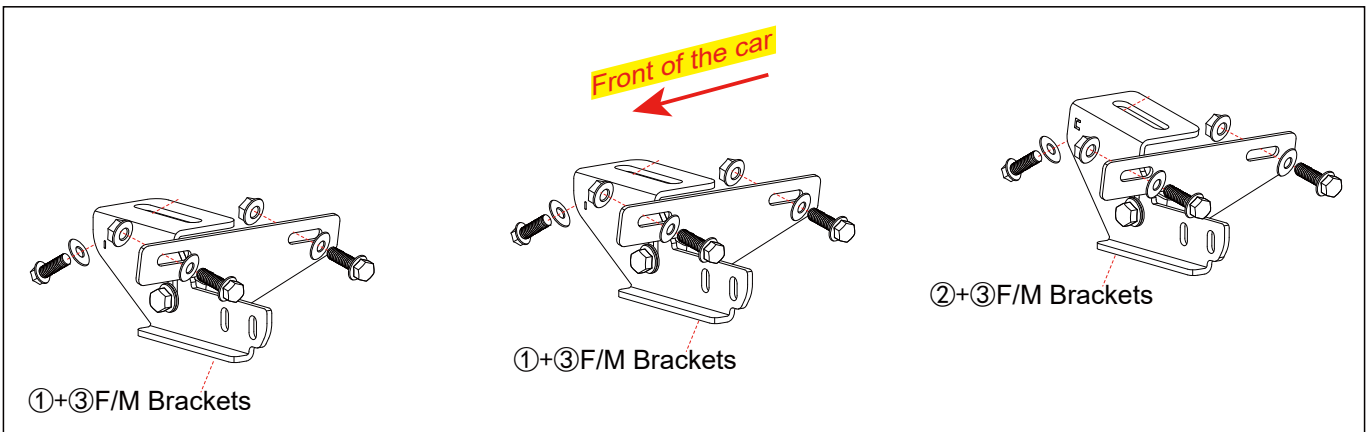
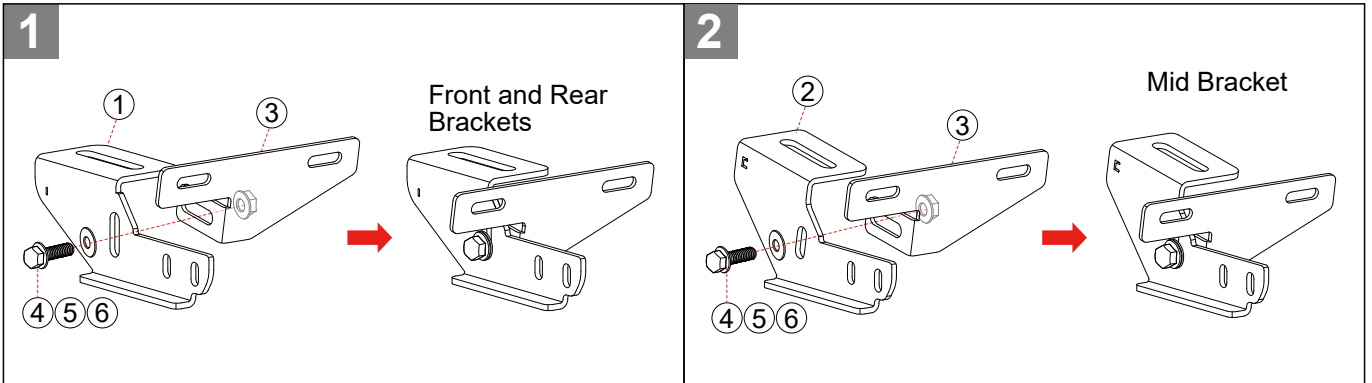
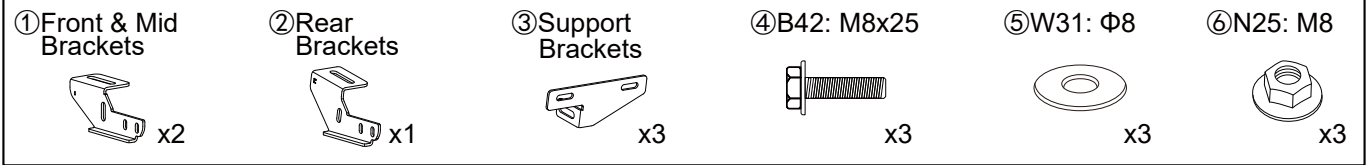

### Step 4: Install the Side Step.

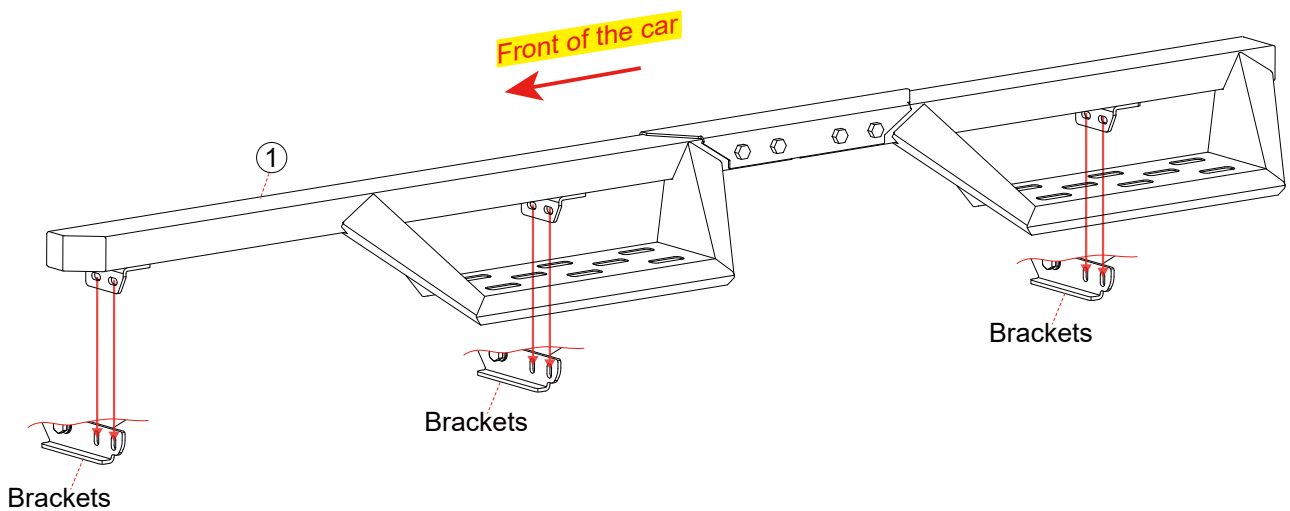
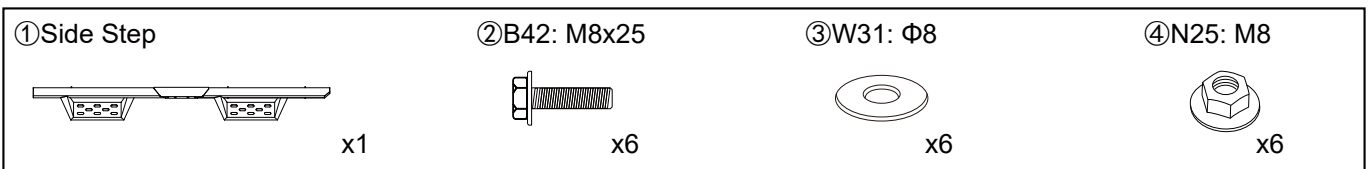

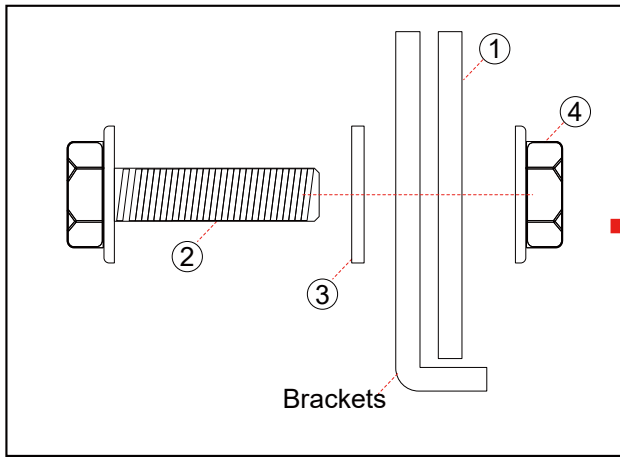

**Step 5:** Adjust the balance of the Side Step and the car side, and tighten the corresponding bolts.

**Step 6:** Adjust the balance of the pedal to the ground and tighten the corresponding bolts.

**Tips:** Use a stretch ruler to measure and balance the left and right sides of the pedal. Please ensure that the pedal has the same distance to the ground on both sides.

**Step 7:** Installation of a Side Step is complete. Please do periodic inspections of the Side Step to make sure that all hardware is secure and tight.