

REAR BUMPER

————— User Manual —————

17-22 Ford F-250

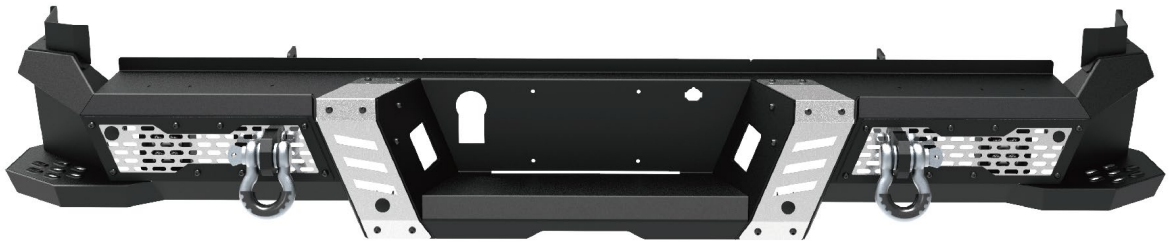

NF201B101

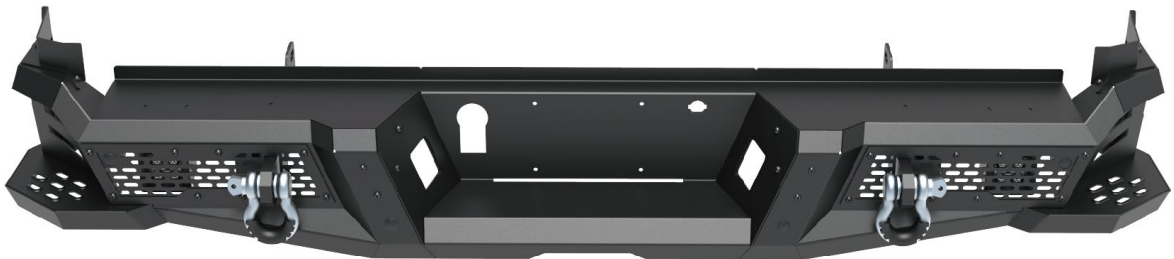

NF201B102

Model:	NF201B101 & NF201B102
Material:	Q235A
Product Dimensions:	76 x 15.3 x 10.8 inch
Package Dimensions:	34.6 x 22 x 12.6 inch
Product Weight:	81.2 lbs

※ Thank you for purchasing the REAR BUMPER. Please read this manual carefully and keep it properly if you need to refer to it afterward. If you need any support or assistance, please contact us with your product model number and order number, and our support team will help you solve problems.





⚠ WARNING

※ This product is designed primarily to enhance the appearance of the vehicle. Do not rely in any way on the components of this product to protect against injury or death in the event of an accident. To reduce the risk of serious injury or property damage, please read all safety messages and understand all instructions and procedure notices before attempting to install or use this product.





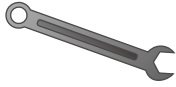

⚠ CAUTION



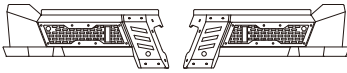
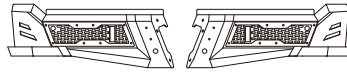
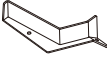

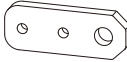

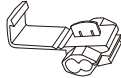
※ Properly torque and recheck fasteners and security of step tread after 250 miles and inspect frequently. Do not use if damaged.

REQUIRED TOOLS

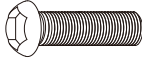
Socket 	Ratchet 	Wrench 	Allen Wrench 	Safety Glasses 
---	--	---	--	---

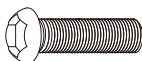
Parts Information

NO.		Parts Name	Size	Line Graph	Qty	Color
①	/	Mid Bumper	/		1	Black
②	101	Side Wings	/		1	Black
	102		/	 or 		
③	/	Side Wings Cover L/R	/		2	Black
④	/	Brackets L/R	/		2	Black
⑤	/	Trailer Hitch	/		2	Black
⑥	/	Led lights	4inch		2	/
⑦	/	Cable Wires	2x0.75mm		2	/
⑧	/	Wire Connector Clips	/		8	/
⑨	/	Shackles	/		2	/
⑩	/	Zip ties	/		10	/

NO.		Parts Name	Size	Line Graph	Qty	Color
⑪	B15	Half Head Allen Bolts	M8x20		9	Dacro Black
⑫	N14	Hex Flange Nuts	M8		9	Dacro Black
⑬	B74	Half Head Allen Bolts	M6x35		5	Dacro Black
⑭	N11	Hex Lock Nuts	M6		5	Dacro Black
⑮	B06	Half Head Allen Bolts	M6x15		5	Dacro Black
⑯	N09	Hex Flange Nuts	M6		5	Dacro Black
⑰	B75	Hex Bolts	M12x45		9	Blue Zinc Plating
⑱	W29	Spring Washer	Φ12		9	Blue Zinc Plating
⑲	W28	Flat Washer	Φ12x30x3		17	Blue Zinc Plating
⑳	N24	Hex Nuts	M12		9	Blue Zinc Plating

NOTE:

Spare parts such as B15、 N14、 B74、 N11、 B06、 N09、 B75、 W29、 W28、 and N24 are provided with 1PCS each (included in the number of parts details).

Installation Instructions

- Step 1:** Open the carton and take out the parts. Check whether the number of components is complete.
- Step 2:** Unplug the connector on the back side of the trailer plug and the parking sensor/license plate light connector. The parking sensor/license plate light connect sits right next to the trailer plug connector and is accessible from underneath the truck. **(Figure 1)**
- Step 3:** Use the vehicle's key to unlock the spare tire lock and remove it from the OEM bumper. **(Figure 2)**

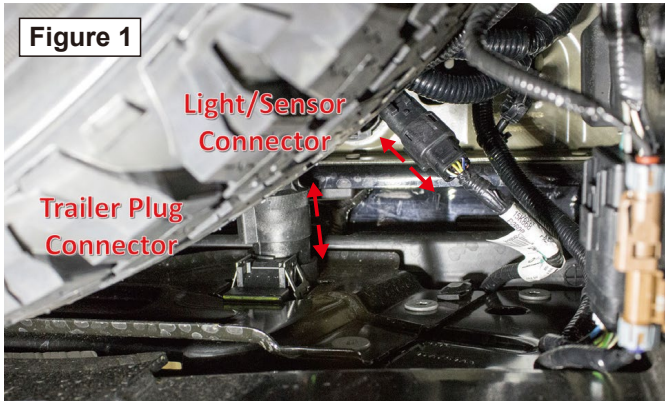

- Step 4:** Remove the trailer plug from your OEM bumper by pressing in the tabs on the back side of the trailer plug and pushing the trailer plug out the front side of the bumper. **(Figure 3)**
- Step 5:** Remove the metal bracket on the top side of the trailer hitch. Do this by using a 13mm to remove both mounting bolts. **(Figure 4)**



Step 6: There are two outer bumper mounting bolts per side. Use a 21mm Socket to remove these bolts. Then, remove the OEM bumper. **(Figure 5~6)**

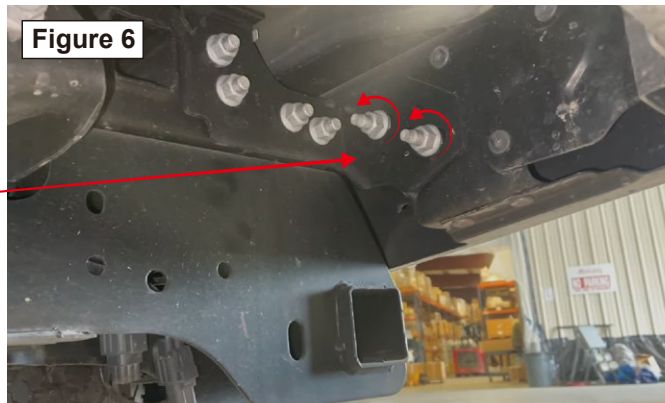
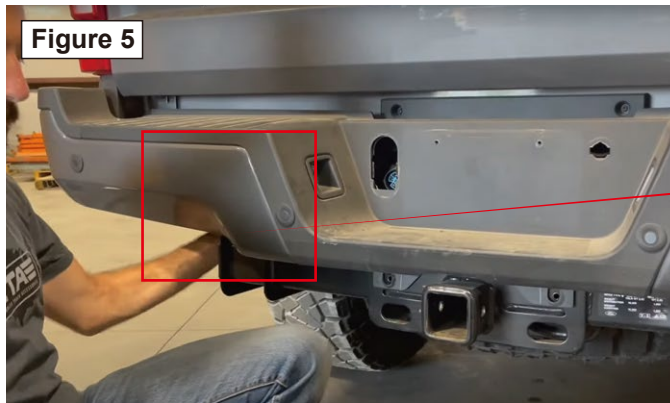

Step 7: Remove the OEM Bumper Mounting Brackets. Use a 21mm Socket to remove the four mounting bolts (per side). Then, remove the brackets. **(Figure 7)**

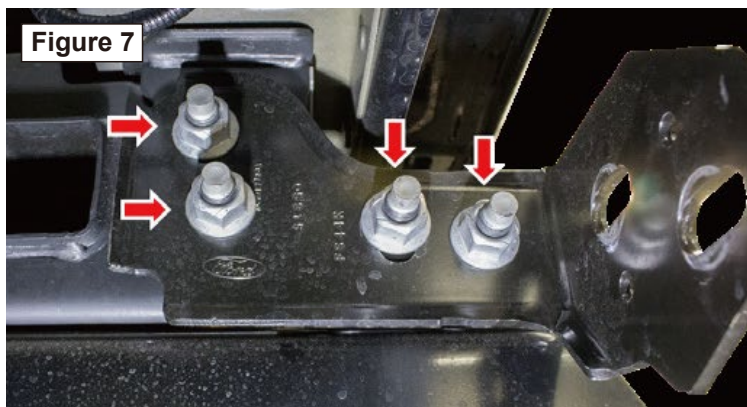

Step 8: Use a T30 Torx Socket to remove the plastic trim piece directly under the tailgate. **(Figure 8)**

Step 9: Remove the parking sensors from their outer mounting rings. Do this by spreading the two tabs on the back side of the outer mounting ring. Then, push the sensor out the back side of the mounting ring. Leave the parking sensors plugged into the rear bumper wiring harness. Make sure to keep track of where each sensor was mounted on the OEM bumper. You have to mount them on your new bumper in the same order. **(Figure 9)**

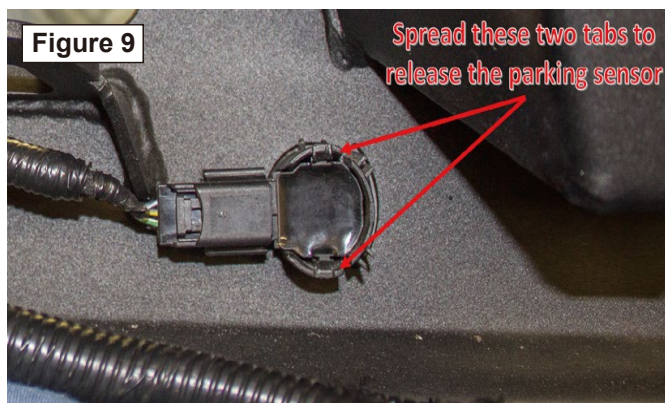
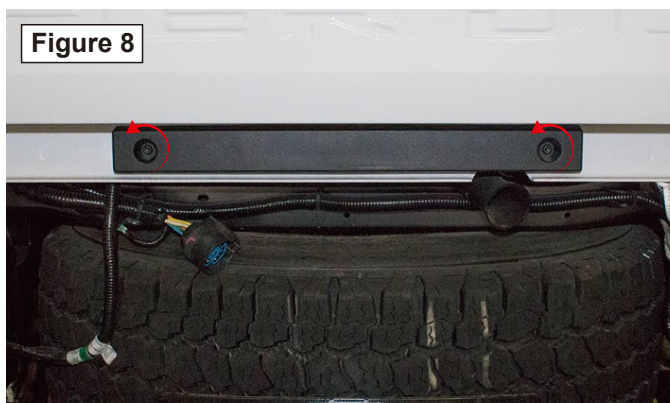

Step 10: Disconnect the license plate light plug from the parking sensor harness. **(Figure 10)**

Step 11: Remove the license plate light housings from your OEM Bumper by pressing in the tabs on the back side of the housings and pushing the housings out the front side of the bumper. **(Figure 11)**



Step 12: Splicing the rear bumper.

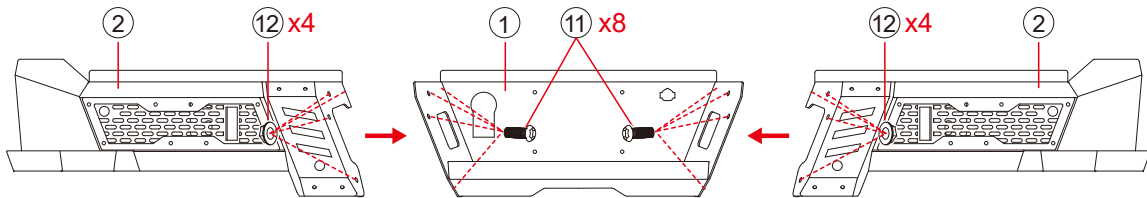
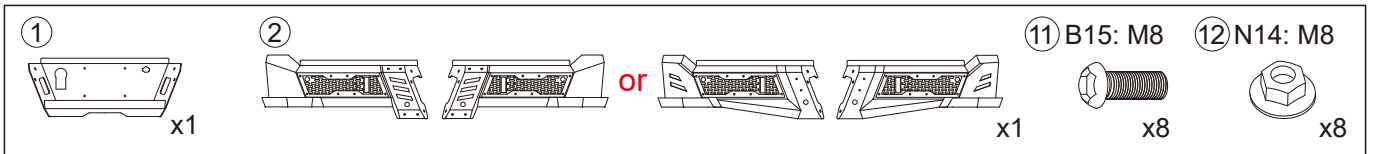

NF201B101

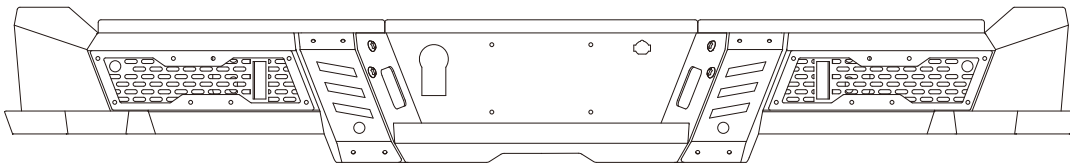



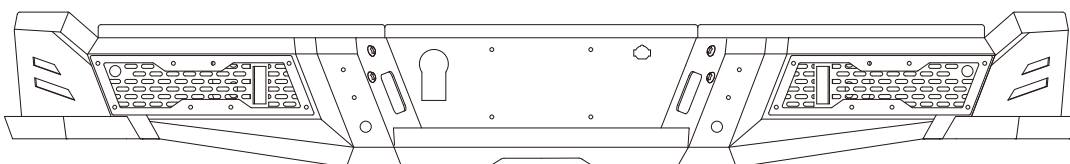

or

NF201B102

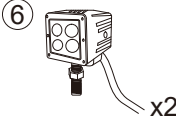
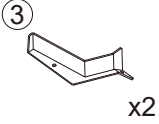

The bumper is assembled

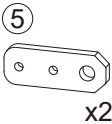
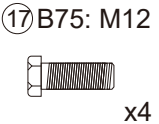
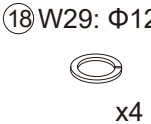
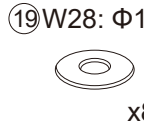
Step 13: Install the Side Wings Cover L/R, Led lights and Trailer Hitch.

 <p>⑥ x2</p>	 <p>③ x2</p>	 <p>⑮ B06: M6 x4</p>	 <p>⑯ N09: M6 x4</p>	
 <p>⑤ x2</p>	 <p>⑰ B75: M12 x4</p>	 <p>⑱ W29: Φ12 x4</p>	 <p>⑲ W28: Φ12 x8</p>	 <p>⑳ N24: M12 x4</p>

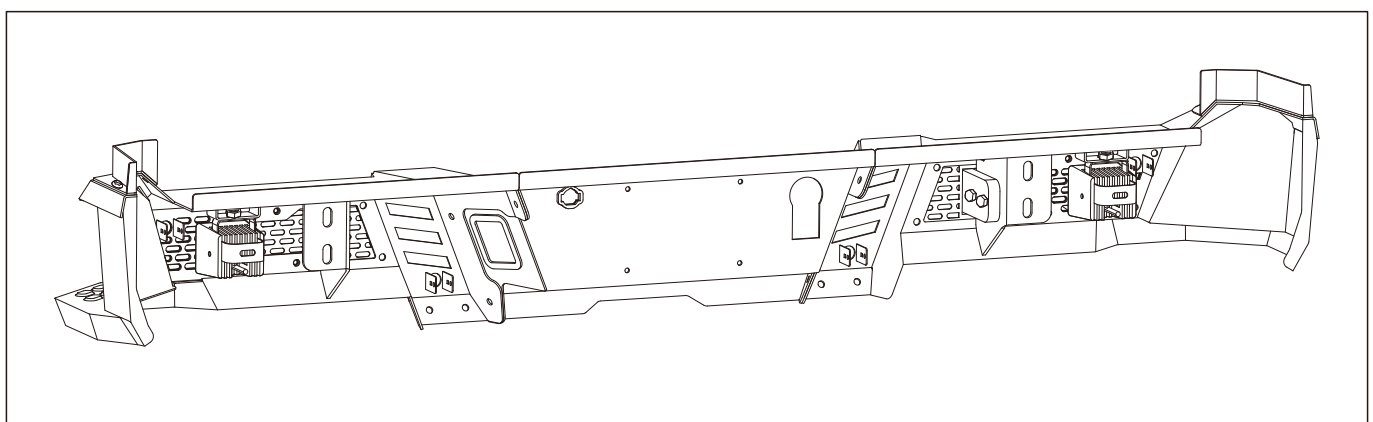
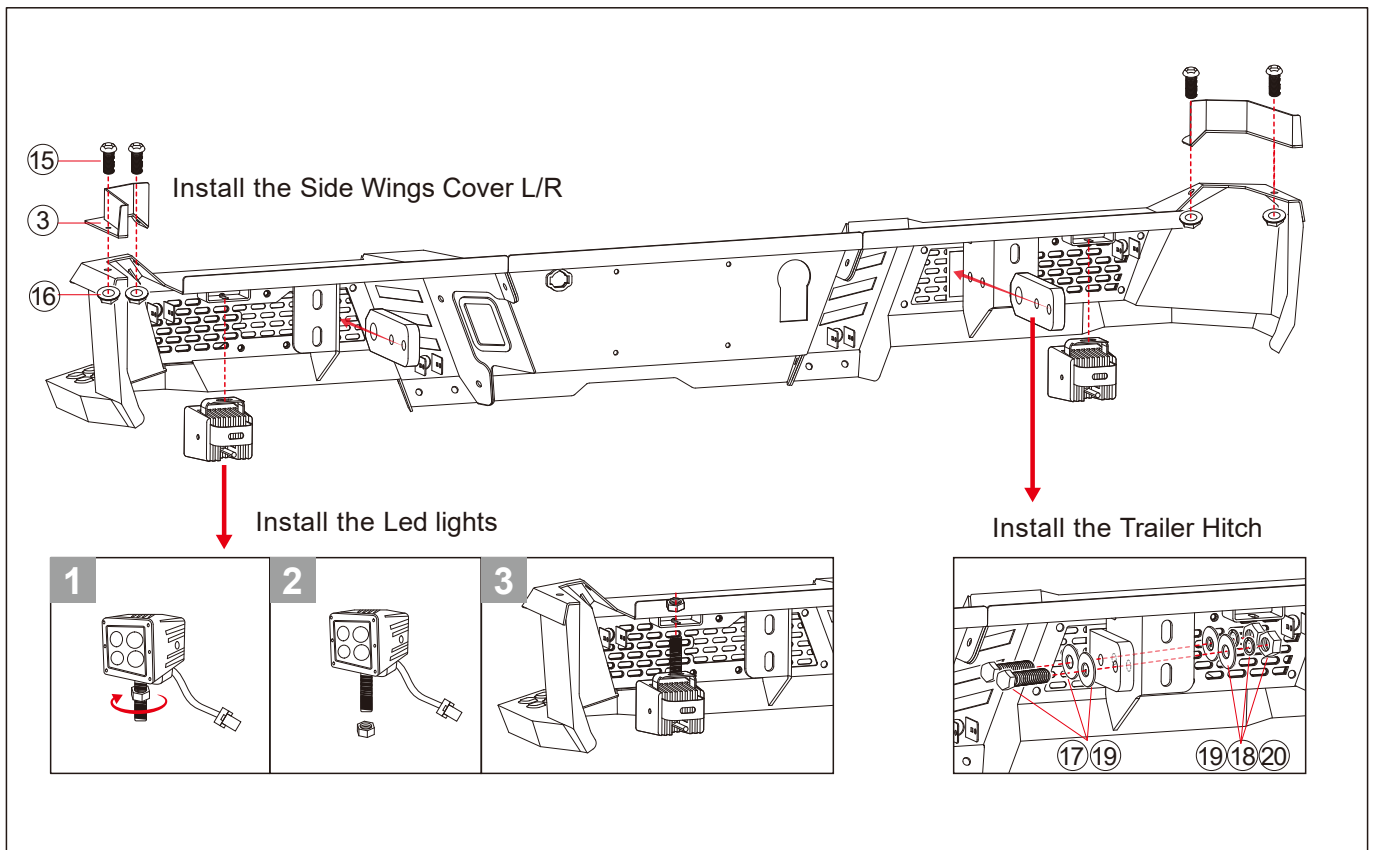

Step 14: Install the Shackles.

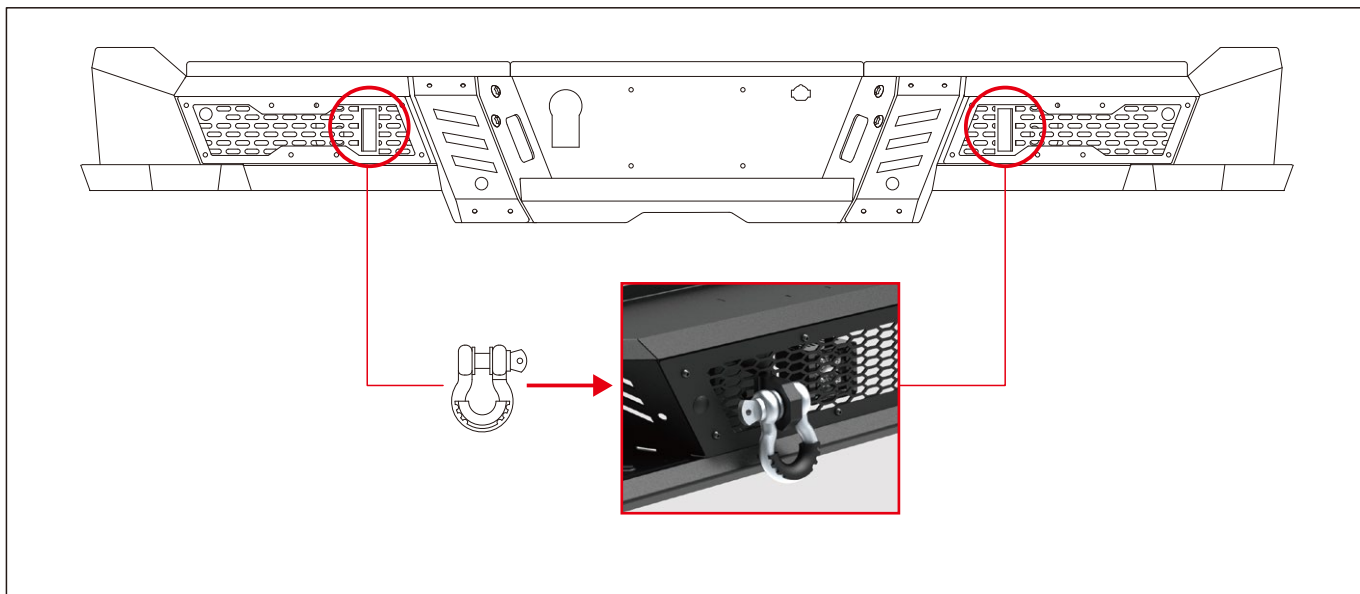

Step 15: Install the license plate light. Seat the clips when installed. (Figure 12~13)

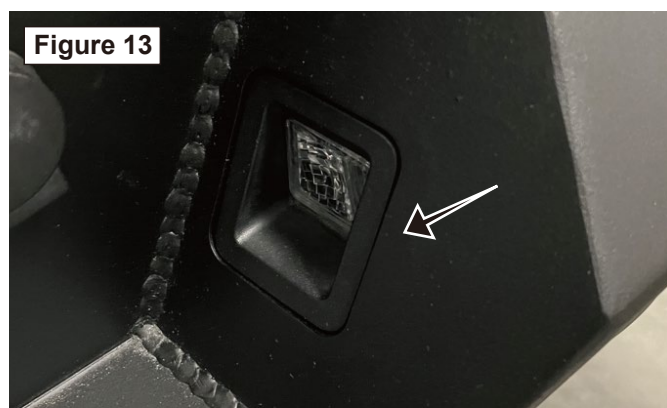

Step 16: Install the spare tire lock. (Figure 14-15)



Step 17: Install the original 7-way trailer plug wiring harness. (Figure 16~17)

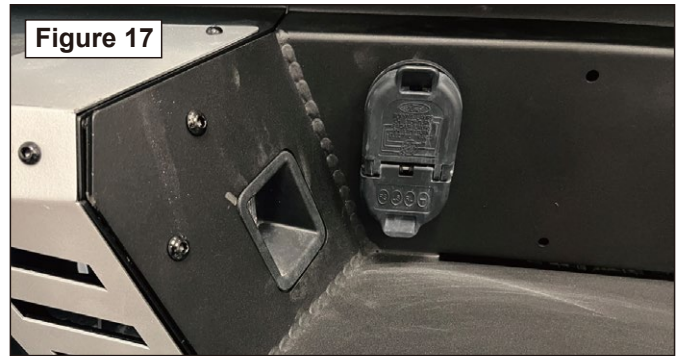

Step 18: Connect the Trailer plug wiring, 4inch Led lights and ⑦ Cabel wires.

7-Way Connector Wiring/Function Diagram

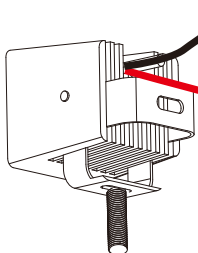
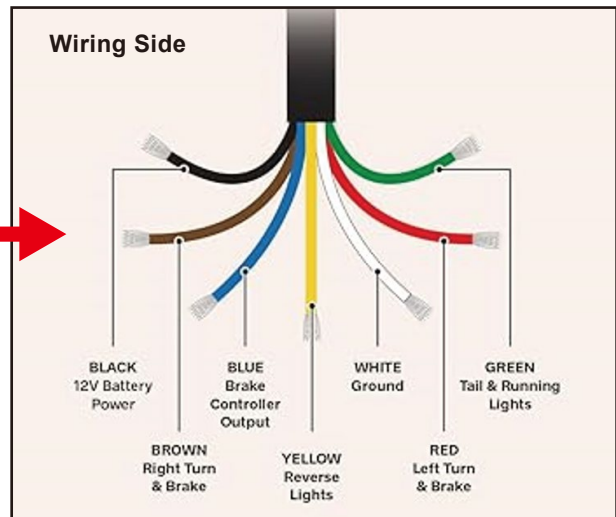
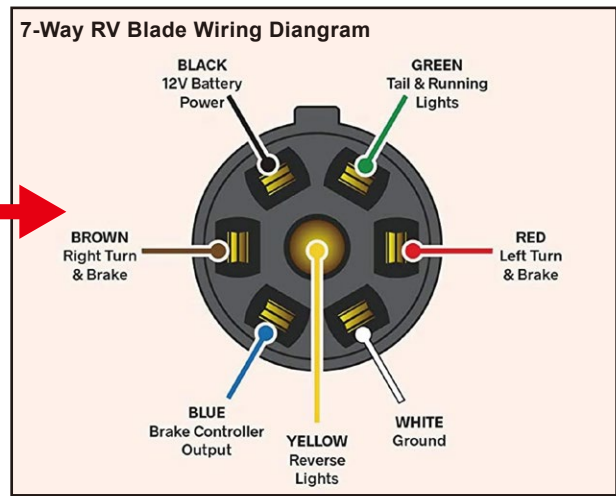

4inch Led light



Cabel wire

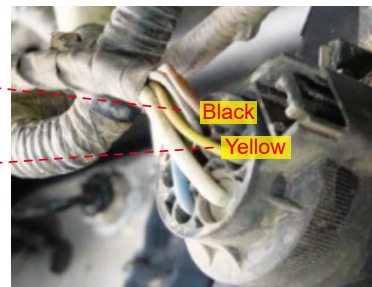

Trailer plug wiring

Step 19: Install the Radar Probe.

NOTE: If the car does not have a radar probe, this step can be ignored.

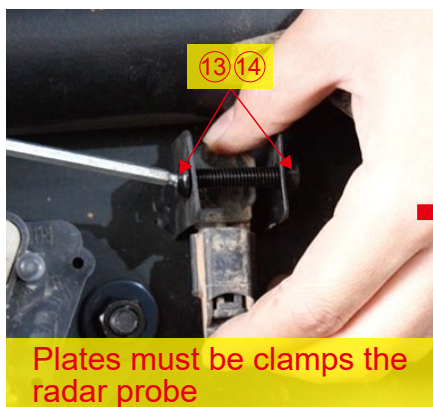
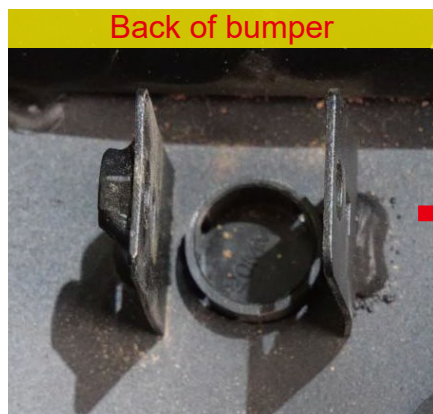

Step 20: Install the Brackets.

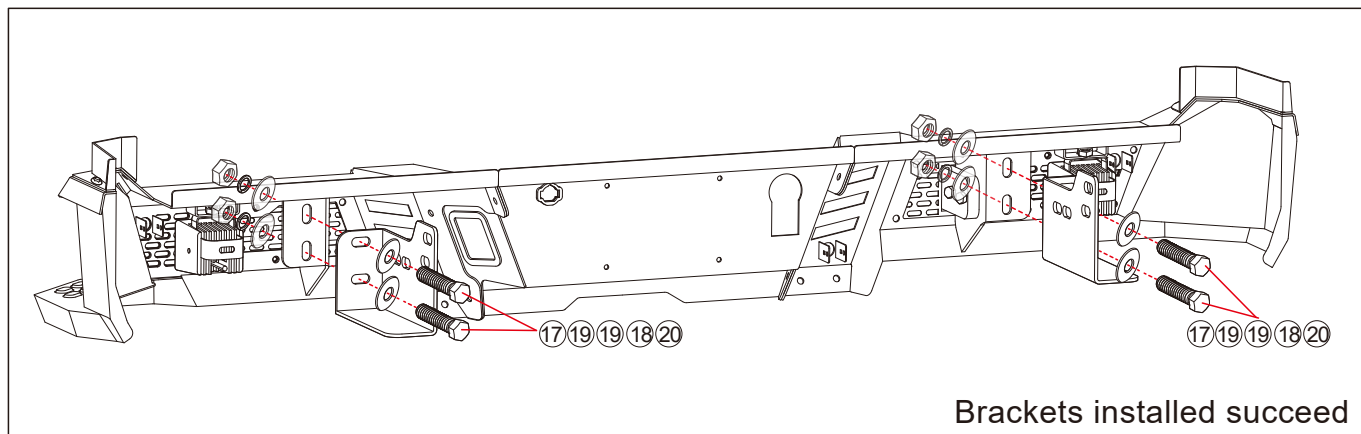
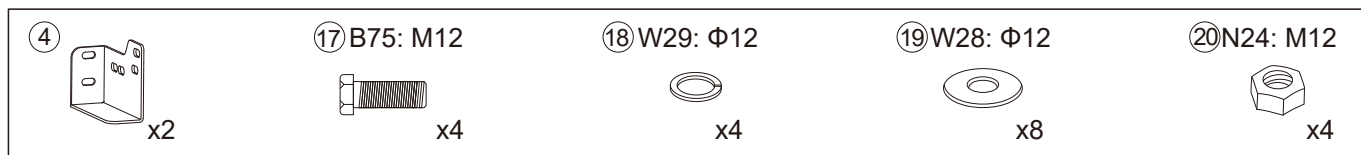

Step 21: Installed the rear bumper on the car using the original bolts.

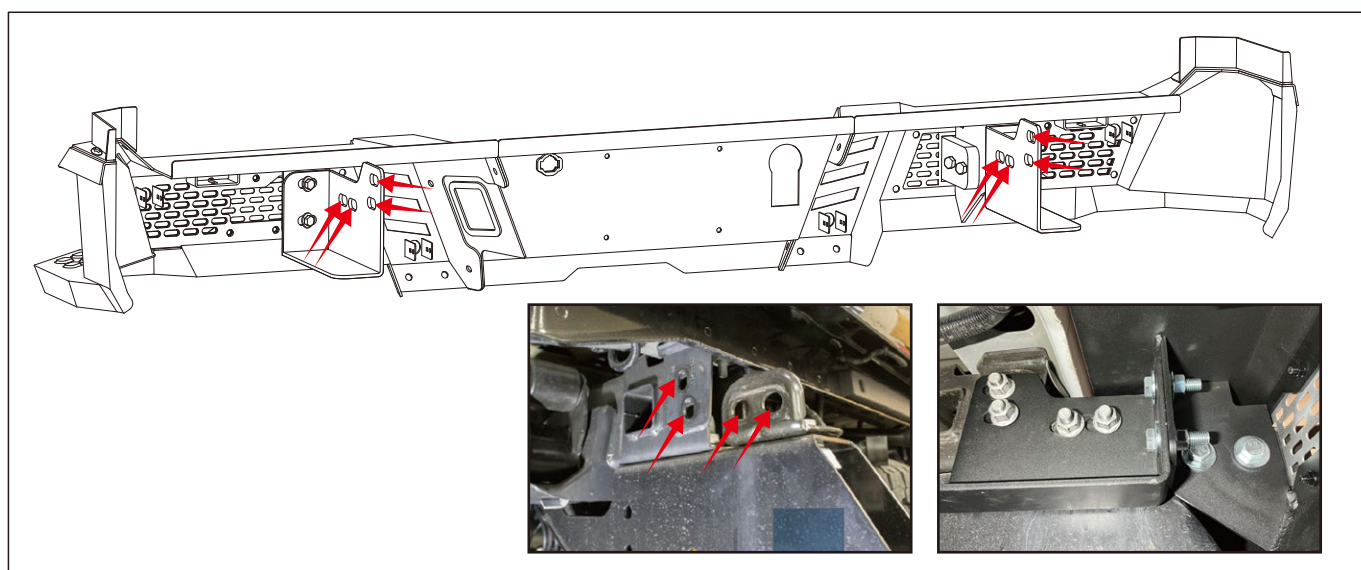

Step 22: Plug in all connectors.

Step 23: Stand back and enjoy your new Rear Bumper.

Step 24: Check and re-tighten, if needed, all mounting bolts after 100 miles and periodically thereafter.

Step 25: The rear bumper is installed.

