

# Greenworks Lithium-ion Battery User Manual

100 Ah

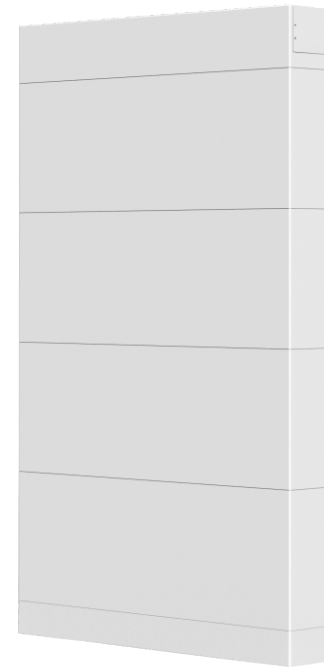

## Copyright Declaration

The copyright of this manual belongs to Greenworks North America, LLC. Any corporation or individual should not plagiarize, partially or fully copy (including software, etc.), and no reproduction or distribution of it in any form or by any means. All rights reserved. Greenworks North America, LLC reserves the right of final interpretation.

# Contents

1	NOTE ON THIS MANUAL	1	6	WIRING	41
1.1	SCOPE OF VALIDITY	1	7	COMMISSIONING	43
1.2	TARGET GROUP	1	7.1	COMMISSIONING	43
1.3	SYMBOLS	1	7.2	STATUS INDICATORS	44
2	SAFETY	2	7.2.1	BMS (GWU-BAT-BMS)	44
2.1	SAFETY INSTRUCTIONS	2	7.3	SHUTTING DOWN GWU-BAT SYSTEM	46
2.1.1	GENERAL SAFETY PRECAUTIONS	2	8	TROUBLESHOOTING	47
2.1.2	EXPLANATION OF SYMBOLS	3	8.1	TROUBLESHOOTING	47
2.2	RESPONSE TO EMERGENCY SITUATIONS	4	9	DECOMMISSIONING	51
2.2.1	LEAKING BATTERIES	4	9.1	DISMANTLING THE BATTERY	51
2.2.2	FIRE	4	9.2	PACKING	51
2.2.3	WET BATTERIES AND DAMAGED BATTERIES	4	10	MAINTENANCE	52
2.3	QUALIFIED INSTALLER	5	11	DISCLAIMER	53
3	PRODUCT INFORMATION	6			
3.1	DIMENSIONS AND WEIGHT	6	*	WARRANTY REGISTRATION FORM	
3.2	APPEARANCE	7			
3.3	BASIC FEATURES	9			
3.2.1	FEATURES	9			
3.2.2	CERTIFICATIONS	9			
3.4	SPECIFICATIONS	10			
3.4.1	GWU-BAT CONFIGURATION LIST	10			
3.4.2	PERFORMANCE	10			
4	PREPARATION BEFORE INSTALLATION	11			
4.1	PREREQUISITES	11			
4.2	SAFETY GEAR	12			
4.3	TOOLS	12			
4.4	INSPECTION	13			
4.4.1	CHECK FOR TRANSPORT DAMAGE	13			
4.4.2	UNPACKING	13			
4.4.3	ACCESSORIES	14			
5	INSTALLMENT	16			
5.1	INSTALLATION ENVIRONMENT REQUIREMENTS	16			
5.2	INSTALLATION MODE	16			
5.3	FLOOR MOUNTING	17			
5.3.1	OVERVIEW	17			
5.3.2	STEP	20			
5.4	WALL MOUNTING	28			
5.4.1	OVERVIEW	28			
5.4.2	STEP	31			
5.5	STEPS FOR INCREASING BATTERY CAPACITY	40			

## 1 Note on this Manual

### 1.1 Scope of Validity

This manual is an integral part of the GWU-BAT Series. It describes the assembly, installation, commissioning, maintenance and failure of the product. Read it carefully prior to operation.

GWU-BAT-5.0 BMS

---

GWU-BAT-BMS

---

GWU-BAT-5.0 Module

---

GWU-BAT-5.0H

---

Note: There are 3 models of GWU-BAT system, which includes the BMS, battery module(s) and base. Refer to section 3.3.1 GWU-BAT Configuration List on Page 11 for detailed models.

### 1.2 Target Group

This manual is for qualified electricians. The tasks described in this manual may only be performed by qualified electricians.

### 1.3 Symbols

The following types of safety instructions appear in this document and are described below:



#### DANGER!

“DANGER” indicates a hazardous situation which, if not avoided, will result in serious injury or death.



#### WARNING!

“WARNING” indicates a hazardous situation which, if not avoided, could result in serious injury or death.



#### CAUTION!

“CAUTION” indicates a hazardous situation which, if not avoided, could result in minor or moderate injury.



#### NOTE!

“NOTE” provides tips that are valuable for the optimal operation of your product.

## 2 Safety

### 2.1 Safety Instructions

For safety reasons, installers are responsible for familiarizing themselves with the contents of this manual and all warnings before performing installation.

#### 2.1.1 General Safety Precautions

	<p><b>WARNING!</b> Do not crush or impact the battery, and always dispose of it according to safety regulations.</p>
---	--









Observe the following precautions:

- Risks of explosion:
  - Do not subject the battery module to heavy impacts.
  - Do not crush or puncture the battery module.
  - Do not dispose of the battery module in a fire.
- Risks of fire:
  - Do not expose the battery module to temperatures in excess of 140°F (6°C).
  - Do not place the battery module near a heat source, such as a fireplace.
  - Do not expose the battery module to direct sunlight.
  - Do not allow the battery connectors to touch conductive objects such as wires.
- Risks of electric shock:
  - Do not disassemble the battery module.
  - Do not touch the battery module with wet hands.
  - Do not expose the battery module to moisture or liquids.
  - Keep the battery module away from children and animals.
- Risks of damage to the battery module:
  - Do not expose the battery module to liquids.
  - Do not subject the battery module to high pressures.
  - Do not place any objects on top of the battery module.

GWU-BAT should only be installed for residential applications and not be for commercial applications.

	<p><b>CAUTION!</b> If the battery is not installed within one month after receipt, it must be charged for maintenance. Non-operational batteries should be discarded according to local regulations.</p>
---	--

#### 2.1.2 Explanation of Symbols

Symbol	Explanation
	CSA mark for UL1973
	The battery system must be disposed of at a proper facility for environmentally-safe recycling.
	Do not dispose of the battery together with household waste.
	Read the enclosed documentation.
	Keep the battery system away from open flames or ignition sources.
	Keep the battery system away from children.
	Caution, risk of electric shock
	Caution, risk of danger
	The battery module may explode.

## 2.2 Response to Emergency Situations

### 2.2.1 Leaking Batteries

In case the leakage of electrolyte solution occurs, please avoid direct contact with the electrolyte solution and the gas that may be generated by it. Direct contact may lead to skin irritation or chemical burns. If the user comes into contact with the electrolyte solution, please do as follows:

Accidental inhalation of harmful substances: Evacuate from the contaminated area, and seek medical attention immediately.

Eye contact: Rinse eyes with flowing water for 15 minutes, and seek medical attention immediately.

Dermal contact: Wash the affected area thoroughly with soap and water, and seek medical attention immediately.

Ingestion: Induce vomiting, and seek medical attention immediately.

### 2.2.2 Fire

Please keep a Class ABC fire extinguisher or a carbon dioxide extinguisher near the equipment.



**WARNING!**  
The battery module may catch fire when heated above 302°F.

If a fire breaks out where the battery module is installed, please do as follows:

- 1) Extinguish the fire before the battery module catches fire;
- 2) If the battery module catches fire, please do not try to put out the fire, and evacuate immediately.

**WARNING!**  
In case of catching fire, the battery module will produce noxious and poisonous gases, and please keep away the battery.

### 2.2.3 Wet Batteries and Damaged Batteries

Do not touch the battery module after being wet from and soaked in the water. Do not use the battery module if it is damaged. Otherwise, the loss to life and property will be caused.

Please pack the battery in its original packaging, and return it to Greenworks or the distributor.

**CAUTION!**  
Damaged batteries may leak electrolyte or produce flammable gas. If a user suspects that the battery is damaged, please immediately contact Greenworks for advice and information.

## 2.3 Qualified Installer

**WARNING!**  
All operations of GWU-BAT relating to electrical connection and installation must be carried out by qualified personnel.

A skilled worker is defined as a trained and qualified electrician or installer who has all of the following skills and experience:

- Knowledge of the functional principles and operation of grid-tied systems;
- Knowledge of the dangers and risks associated with installing and using electrical devices and acceptable mitigation methods;
- Knowledge of the installation of electrical devices;
- Knowledge of and adherence to this manual and all safety precautions and best practices.

### 3 Product Information

#### 3.1 Dimensions and Weight

A battery management system (BMS) is an electronic system that manages a rechargeable battery.

A battery module is a type of electrical battery which can charge or discharge loads.

The whole system mainly comprises a BMS, a battery module and a base.

	Base	GWU-BAT-BMS	GWU-BAT-5.0H
Length	33.46 in./850.00 mm	33.46 in./850.00 mm	33.46 in./850.00 mm
Width	5.83 in./148.00 mm	5.83 in./148.00 mm	5.83 in./148.00 mm
Height	2.95 in./75.00 mm	5.24 in./133.00 mm	11.81 in./300.00 mm
Weight	9.92 lbs/4.50 kg	22.05 lbs/10.00 kg	117.95 lbs/54.00 kg

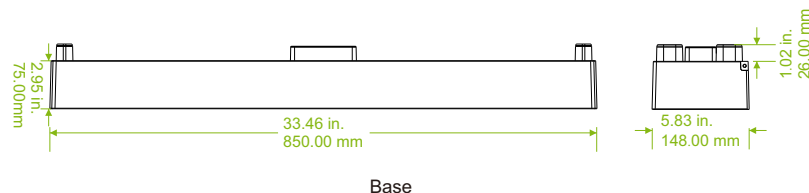
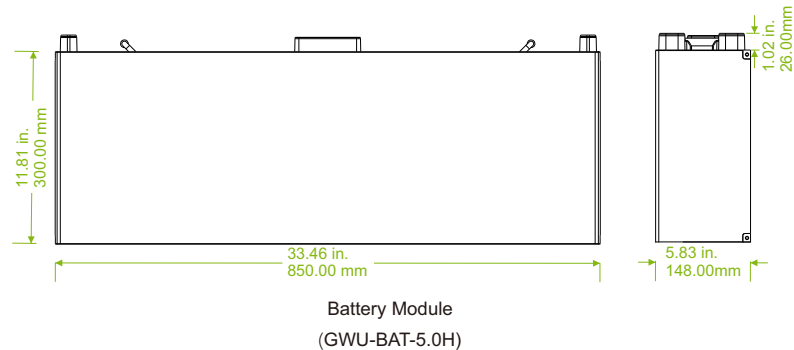
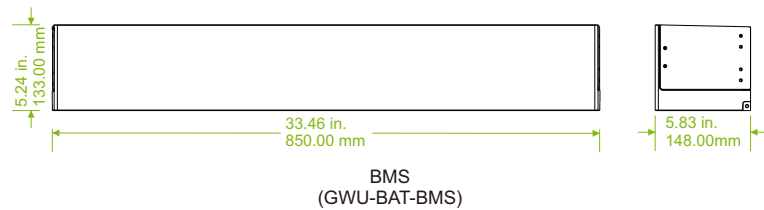

#### 3.2 Appearance

- Section View of BMS

Right

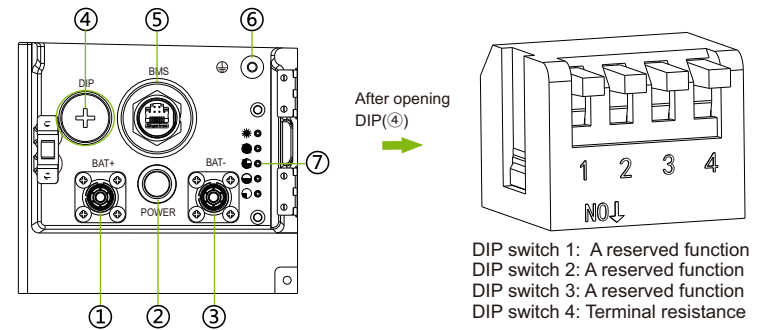

Item	Description
①	BAT+: Connect BMS's BAT+ to the inverter's BAT+
②	Button: BMS's power button
③	BAT-: Connect BMS's BAT- to the inverter's BAT-
④	DIP: Realize the battery's parallel function (A reserved function)
⑤	BMS: Connect the inverter to BMS's communication
⑥	GND: BMS's GND
⑦	Lamp Panel: Status light and SOC power indicators to display battery status

Left

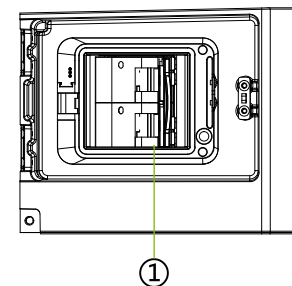

Item	Description
①	Circuit breaker: A switch for battery's input and output

- Section view of battery module

Top

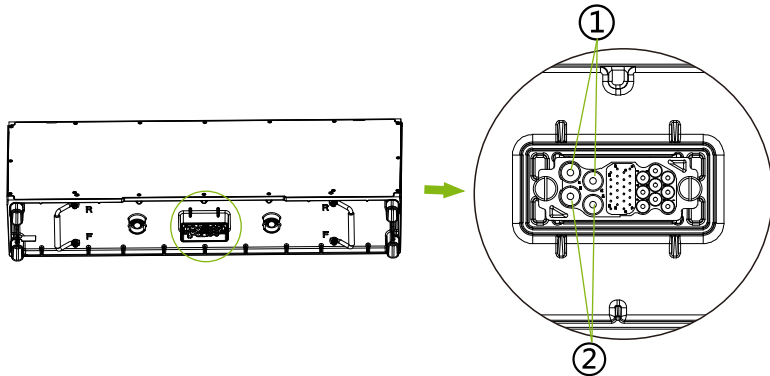

The hot-plug interface is connected to BMS or the bottom of battery	
①	BAT+: Battery's positive output pole (+)
②	BAT-: Battery's negative output pole (-)

Bottom

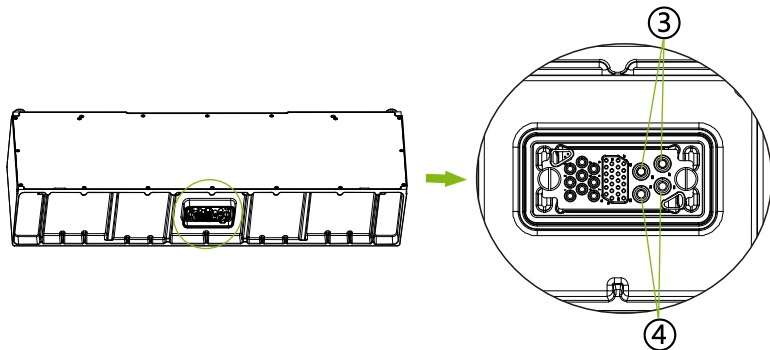

The hot-plug interface is connected to base or the top of battery	
③	Connect the next battery's positive pole or base's shorting stub
④	Connect the next battery's negative pole or base's shorting stub

### 3.3 Basic Features

#### 3.2.1 Features

The GWU-BAT, adopting advanced technology and having the characteristics of high reliability and convenient to control, is one of the most advanced energy storage systems in today's market, with details as below:

- 90% DOD
- 95% Battery Roundtrip Efficiency
- Cycle Life > 6000 Cycles
- Secondary Protection
- IP65 Protection Level
- Safety & Reliability
- Small Occupied Area
- Floor or Wall Mounting

#### 3.2.2 Certification

BAT system safety	UL9540A, UL1973, CE, RCM, IEC 62619
UN number	UN 3480
Hazardous materials classification	Class 9
UN transportation testing requirements	UN 38.3
International protection marking	IP 65

## 3.4 Specifications

### 3.4.1 GWU-BAT Configuration List

No.	Model	BMS	Battery Module	Energy(kWh)	Voltage (V)
1	GWU-BAT-10.0H	GWU-BAT-BMS×1	GWU-BAT-5.0H × 2	10	90-116
2	GWU-BAT-15.0H	GWU-BAT-BMS×1	GWU-BAT-5.0H × 3	15	135-174
3	GWU-BAT-20.0H	GWU-BAT-BMS×1	GWU-BAT-5.0H × 4	20	180-232

### 3.4.2 Performance Parameters

Model	GWU-BAT-10.0H	GWU-BAT-15.0H	GWU-BAT-20.0H
Nominal Voltage (Vdc)	102.4	153.6	204.8
Operating Voltage (Vdc)	90-116	135-174	180-232
Nominal Capacity (Ah) <sup>①</sup>	100	100	100
Nominal Energy (kWh) <sup>①</sup>	10	15	20
Usable Energy 90% DOD (kWh) <sup>②</sup>	9.2	13.8	18.4
Max. Charge/Discharge Current (A) <sup>③</sup>	54	54	54
Recommend Charge/Discharge Current (A)	50	50	50
Standard Power (kW)	5.12	7.68	10.24
Max. Power (kW)	5.5	8.3	11.1
Battery Roundtrip Efficiency(0.2C, 25°C/77°F)	95%		
Expected Lifetime (25°C/77°F)	10 years		
Cycle Life 90% DOD (25°C/77°F)	6000 cycles		
Charge Temperature	32°F~127.4°F/0°C~53°C <sup>④</sup>		
Discharge Temperature	-14°F~127.4°F/-10°C~53°C <sup>④</sup>		
Storage Temperature	-4°F~122°F/-20°C~50°C (3 months)		
	32°F~104°F/0°C~40°C (12 months)		
Ingress Protection	IP65		

Note:

- ① Test conditions: 100% DOD, 0.2C charge & discharge @+ 77°F/25°C.  
 ② 90% DOD; System usable energy may vary with inverter different setting.  
 ③ Discharge: In case of the battery core's temperature range of 14°F~41°F/-10°C~5°C and 113°F~127.4°F/45°C~53°C, the discharge current will be reduced; Charge: In case of the battery core's temperature range of 32°F~68°F/0°C~20°C and 113°F~127.4°F/45°C~53°C, the charge current will be reduced. Product charge or discharge power depends on the actual temperature of the battery pack.  
 ④ The battery can only be discharged and cannot be charged at -14°F~32°F/-10°C~0°C.

## 4 Preparation before Installation

### 4.1 Prerequisites

When assembling the system, avoid touching the battery terminals with any metal object or bare hands. According to the design principles, GWU-BAT will provide a safe and reliable energy. Improper operation and equipment damage may cause overheating and electrolyte leakage. Therefore, the above-mentioned safety precautions and warning information mentioned in this part shall be strictly observed. If you have any question, please contact customer service. The “2 Safety” does not contain the provisions of all laws and regulations at the place where the user located.

Before installation, make sure that the installation site meets the following conditions:

- The building can stand up to earthquakes;
- The site shall be over 0.62 miles/997.79 m away from the sea, to avoid damage caused by salt water and humidity;
- The floor shall be flat;
- No inflammable and explosive goods are placed within at least of 3 ft/0.91 m;
- The ambience shall be shady and cool, away from heat sources and direct sunlight;
- The temperature and humidity remain at a constant level;
- The installation site requires less dust and dirt; and
- There are no corrosive gases, including ammonia and acid vapor.



#### NOTE!

If the ambient temperature exceeds the operating range, the battery pack will stop running to protect itself. The optimal temperature range for running is 59°F/15°C to 86°F/30°C. Frequent exposure to harsh temperatures may deteriorate the performance and lifetime of the battery.



## 4.2 Safety Gear

Installation and maintenance personnel must strictly comply with the applicable federal, state, and local regulations as well as industry standards on product installation. To avoid short circuit and personal injury, respirator, gloves, goggles and shoes must be worn.



Anti-dust respirator



Insulated Gloves



Safety Goggles



Safety Shoes

## 4.3 Tools

Please prepare the following tools before installation.

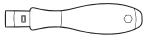

Torque Screw Driver



Phillips-Screw Driver



Hexagon Wrench



Phillips-Head Screw Driver



Torque Wrench



Pencil or Marker

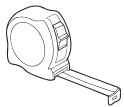

Tape Measure



Drill



Spirit Level

## 4.4 Inspection

### 4.4.1 Check for Transport Damage

Ensure that the battery has been received in good condition. If there is any damage or obvious defect, please contact the dealer immediately.

### 4.4.2 Unpacking

Before opening the battery package, remove the packing tape. After opening the package, ensure that the battery modules and relevant accessories are in good condition, and carefully check the quantity and type of accessories are consistent with the “4.4.3 Accessory”. If any accessory is missing, contact Greenworks or the distributor immediately.



#### CAUTION!

According to the local regulations, more than one person is required to carry the equipment.



#### WARNING!

Strictly follow the installation steps. Greenworks will not be responsible for any injury or loss incurred by improper installation and operation.



#### NOTE!

For the first installation, the interval among manufacture dates of battery modules shall not exceed 3 months.

4.4.3 Accessory

BMS (GWU-BAT-BMS):



Accessories included are shown as follows:		
Item	Description	Quantity
A	BMS	1
B	User Manual	1

One Battery Module (GWU-BAT-5.0H×1):

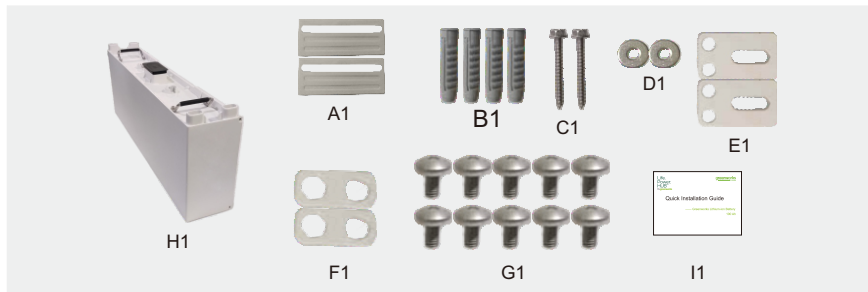

Accessories included are shown as follows:		
Item	Description	Quantity
A1	Wall Bracket	2
B1	Expansion Bolt	4
C1	Tapping Screw	2
D1	Washer	2
E1	Platen (3 holes)	2
F1	Platen (2 holes)	2
G1	M5*10 Phillips-head Screw	10
H1	Battery Module	1
I1	Document	1

Note: The above-mentioned accessories are only for one battery module. Greenworks will provide corresponding accessories according to the number of battery modules.

All Accessories Required for Two Installation Modes



Accessories included are shown as follows:		
Item	Description	Quantity
A2	Base Support	2
B2	Transverse Plate	1
C2	Expansion Screw	6
D2	M5*8 Countersunk Head Screw	4
E2	M5*20 Countersunk Screw	6
F2	Adjustment Screw	4
G2	Self-tapping Screw	6
H2	Washer	6

Note: The above-mentioned accessories are necessities for both floor and wall mounting.

Base for GWU-BAT-5.0H Battery:

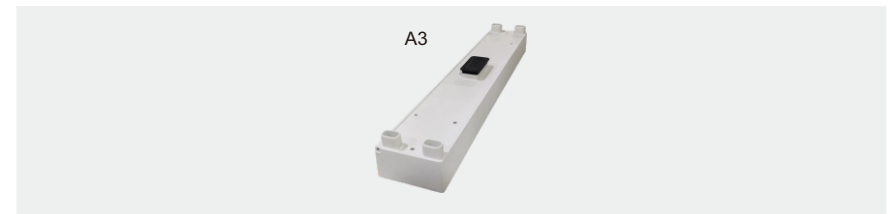

Accessories included are shown as follows:		
Item	Description	Quantity
A3	Base	1

## 5. Installation

### 5.1 Installation Environment Requirements

- Ensure that the equipment is installed in a well ventilated environment.
- To prevent fire due to high temperature, ensure that the ventilation vents or heat dissipation system are not blocked when the equipment is running.
- Do not expose the equipment to flammable or explosive gas or smoke. Do not perform any operation on the equipment in such environment.
- A distance of at least 11.81 in./300 mm shall be set aside from the equipment to both left and right sides.
- In case of Wall Mounting, make sure the wall is strong enough to withstand the weight of battery. In case of wooden wall, it must bear the load of at least 2,204.62 lbs/1,000.00 kg.
- In case of Wall Mounting, do not install on the hollow concrete block wall.

### 5.2 Installation Mode

There are two alternative installation modes and three schemes available for users. For details, refer to the following table.

	Floor Mounting			Wall Mounting			
	BMS	Battery Module	Base	BMS	Battery Module	Base	Base Support
Scheme A	1	2	1	1	2	1	1
Scheme B	1	3	1	1	3	1	1
Scheme C	1	4	1	1	4	1	1

Note: The equipment supports the following stub spacing: 20, 24, 28 and 32 in.

### 5.3 Floor Mounting

#### 5.3.1 Overview

There are three schemes available for users.

#### Scheme A

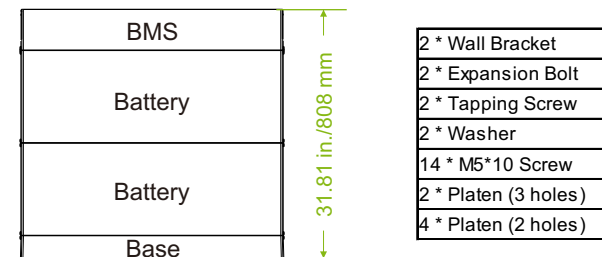

Distance from the equipment:  
 To left side:  $\geq 11.81$  in./300 mm  
 To right side:  $\geq 11.81$  in./300 mm

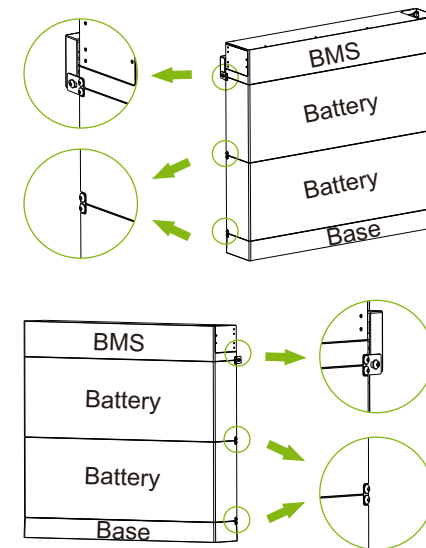

Scheme B

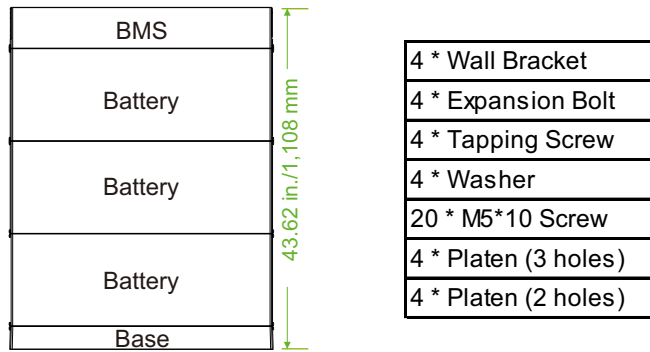

Distance from the equipment:  
 To left side:  $\geq 11.81$  in./300 mm  
 To right side:  $\geq 11.81$  in./300 mm

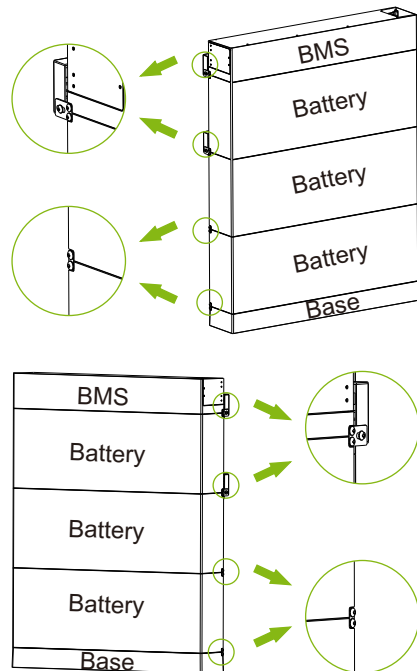

Scheme C

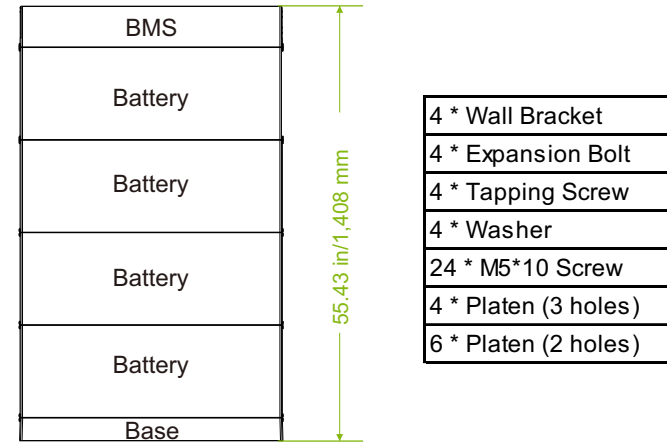

Distance from the equipment:  
 To left side:  $\geq 11.81$  in./300 mm  
 To right side:  $\geq 11.81$  in./300 mm

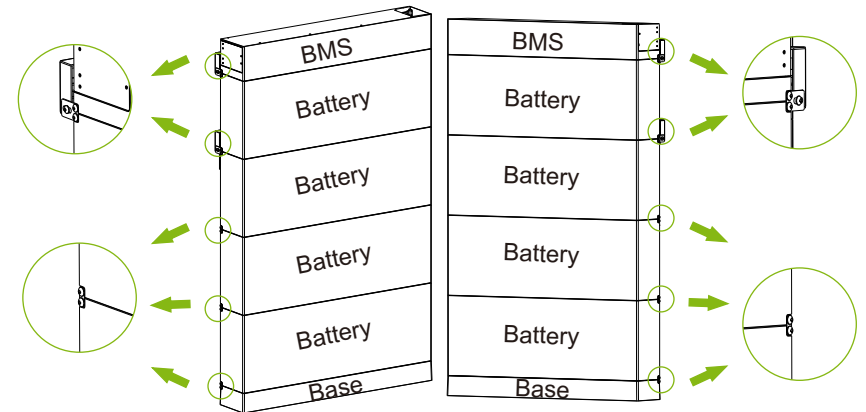

5.3.2 Step

Please reserve enough distance from the equipment to the ceiling/ground for capacity expansion.  
Take Scheme C as an example.

Step 1: Place Base.

(1) Remove the dust cover.

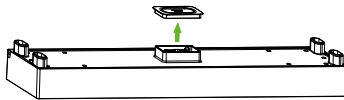

(2) Insert M8\*85 Adjustment Screws from the bottom of Base, to ensure that the Base is even.

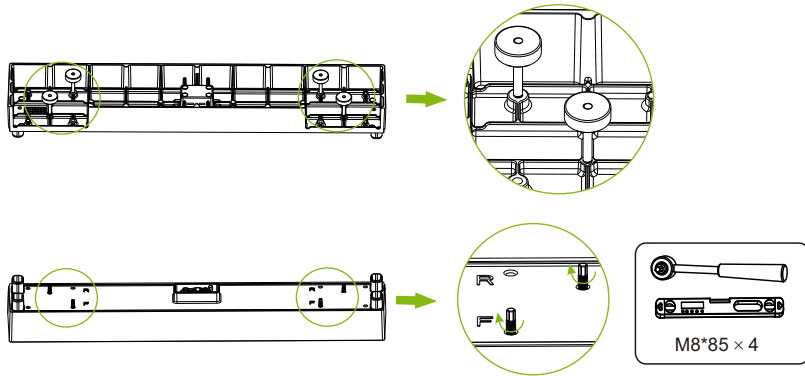

**Note!**

- (a) Use a spirit level to measure the sides of the Base to ensure they are even.
- (b) If not, please adjust the Adjustment Screws by a torque wrench being to ensure that the Base is even.

Step 2: Locate the Base 1.57 in./40 mm away from the wall, accurately mark the location of the Base on both sides with a pen.

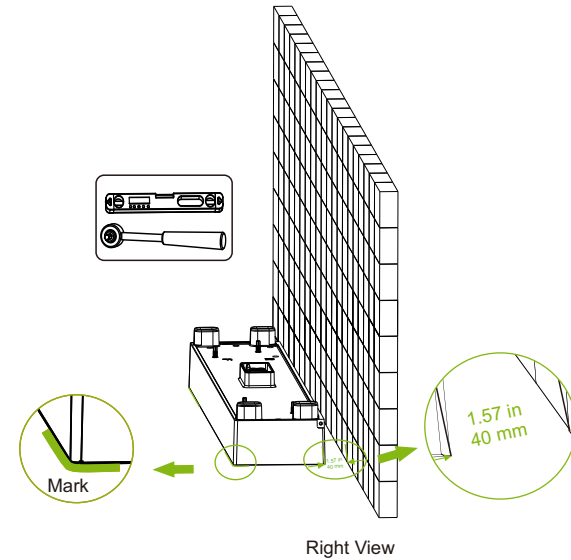

Step 3: Place Battery Module on the Base.

- (1) Remove the top and bottom dust covers.
- (2) Place the Battery Module on the Base.

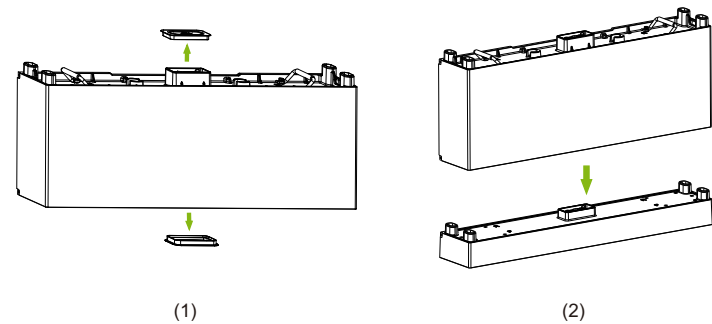

**Note!**

If the Base is shifted after placing a Battery Module, move it to its original location according to the mark previously drawn.

(3) Fix the Platen (2 holes) using M5 \* 10 Phillips-head screw, and secure M5\*10 screws (2) to connect Base and Battery Module (Torque: 2.2-2.5 N·m).

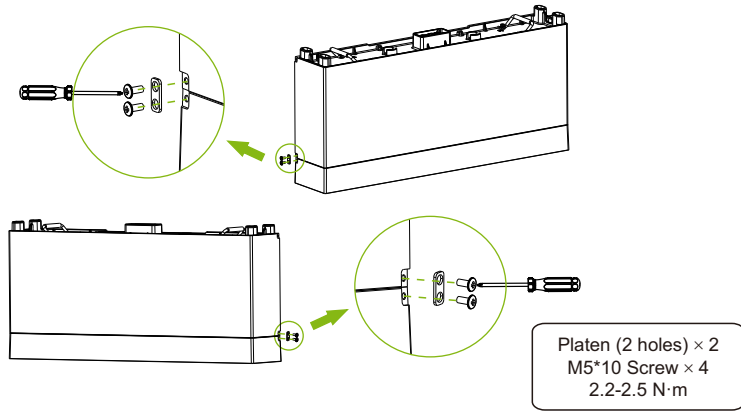

Step 4: Place two Battery Modules in turn, and secure both left and right sides with screws (4 × M5\*10 countersunk screw) (Tighten torque: 2.2-2.5 N·m). Refer to the Step 3 (3).

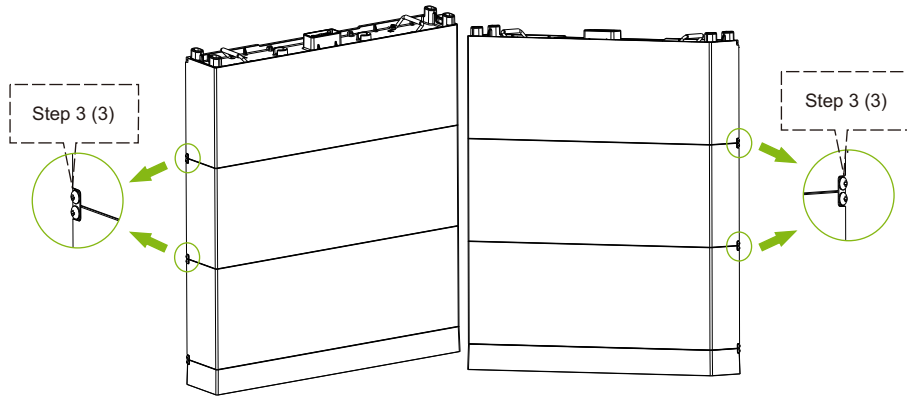

Step 5:

- (1) Attach M5 \* 10 screw to Wall Bracket but be sure not to tighten;
- (2) Place such Wall Bracket to the wall, align its holes to the holes on the Battery Module, and use a spirit level to measure the Wall Bracket to ensure it's even;
- (3) Accurately mark the location of the Wall Bracket on both sides with a pen;
- (4) Draw circles according to the actual stub spacing;
- (5) Remove the Wall Bracket, and then drill the two holes (at least 3.54 in./90 mm) by a Drill ( $\varnothing$  0.39 in./10 mm).

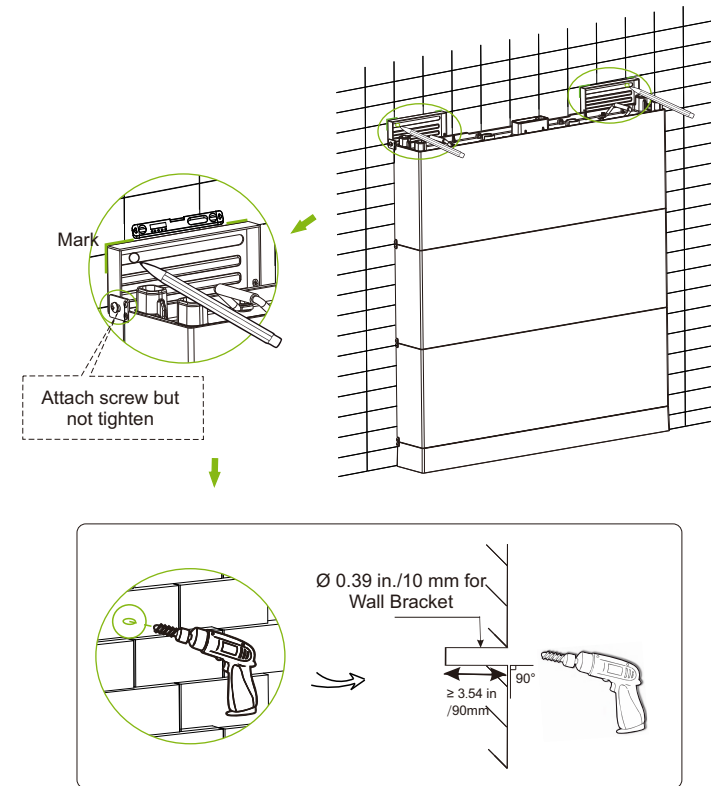

**Note!**

Electric drill dust collector is recommended.

Step 6: Place Expansion Bolts into the two holes (the Expansion Bolt is not required in case of solid wood wall).

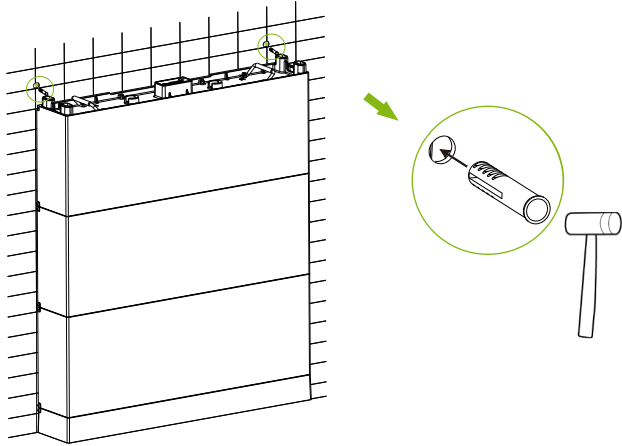

Step 7: Place the Wall Bracket on the wall where the mark is drawn previously, and then secure the Wall Brackets on the wall using Tapping Screws and Washers.

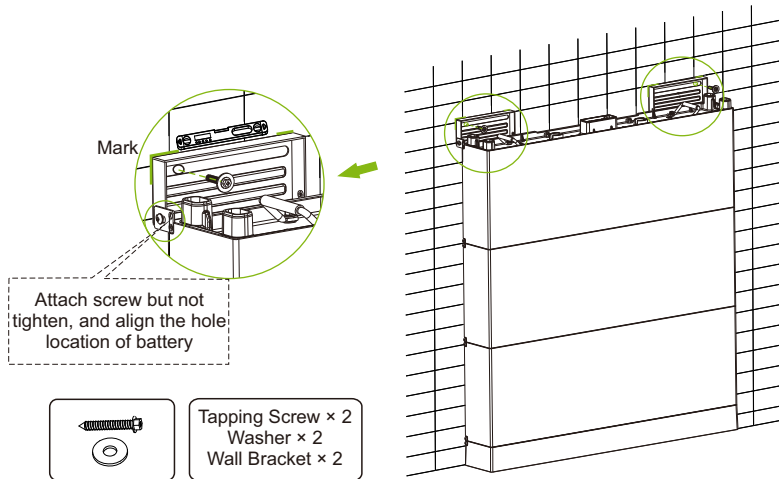

Step 8: Place the fourth battery module.

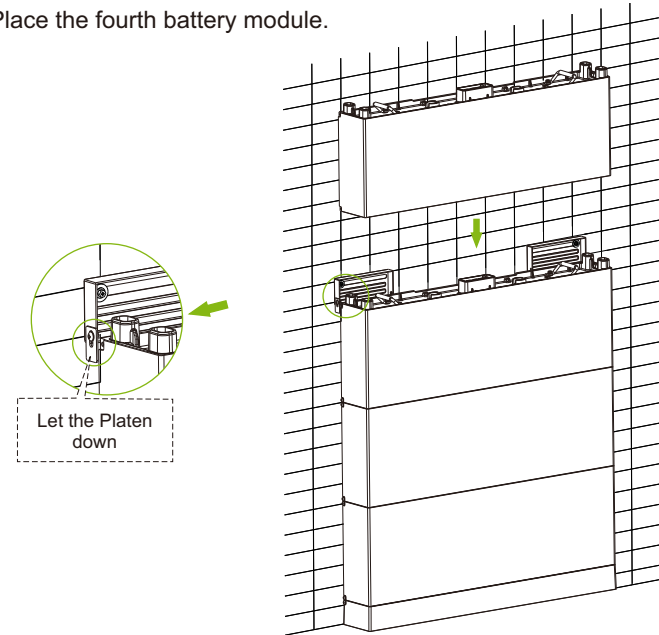

Step 9: Fix the Platen (3 holes) on both sides of Battery Module using M5 \* 10 Phillips-head screw, and then tighten M5\*10 screws (Torque: 2.2-2.5 N·m).

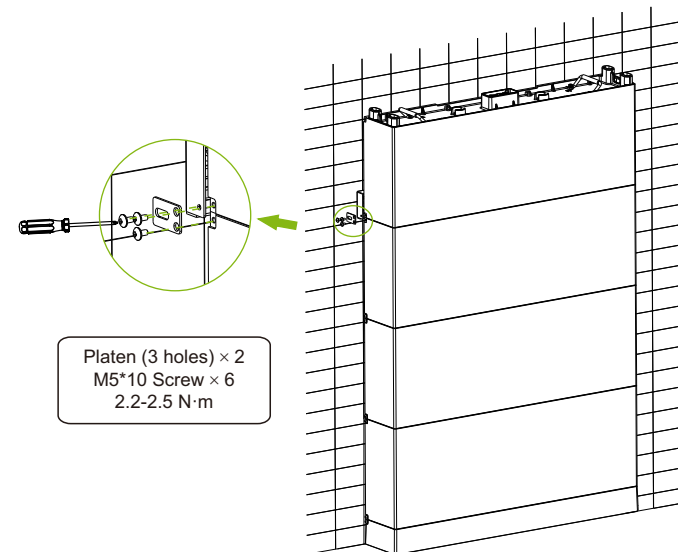

## Step 10:

- (1) Attach M5 \* 10 screw to Wall Bracket but be sure not to tighten;
- (2) Place such Wall Bracket to the wall, align its holes to the holes on the Battery Module, and use a spirit level to measure the Wall Bracket to ensure it's even;
- (3) Accurately mark the location of the Wall Bracket on both sides with a pen;
- (4) Draw circles according to the actual stub spacing;
- (5) Remove the Wall Bracket, and then drill the two holes (at least 3.54 in./90 mm) by a Drill ( $\varnothing$  0.39 in./10 mm);
- (6) Place Expansion Bolts;
- (7) Secure Wall Brackets using Tapping Screws and Washers. Refer to the Steps 5, 6, 7 and 8.

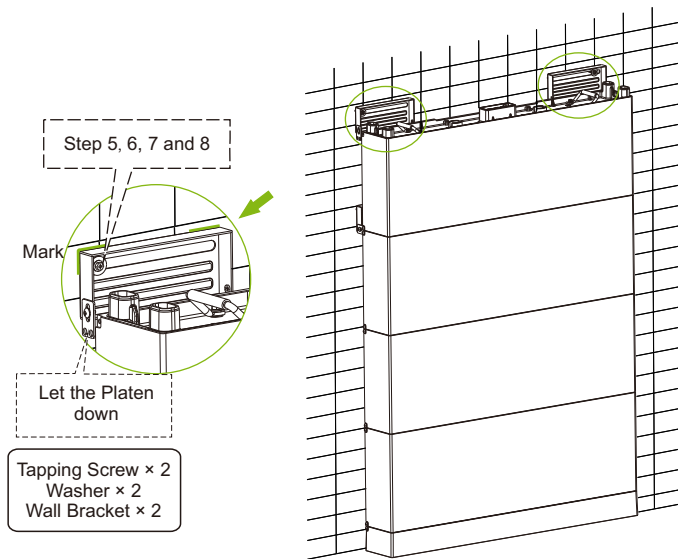
**Note!**

Electric drill dust collector is recommended.

## Step 11: Place BMS on the Battery Module.

- (1) Remove the bottom dust cover.

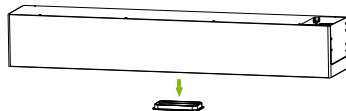

- (2) Place the BMS, fix the Platen (3 holes) on both sides of Battery Module using M5 \* 10 Phillips-head screw, and then tighten M5\*10 screws (Torque: 2.2-2.5 N·m). Refer to Step 9.

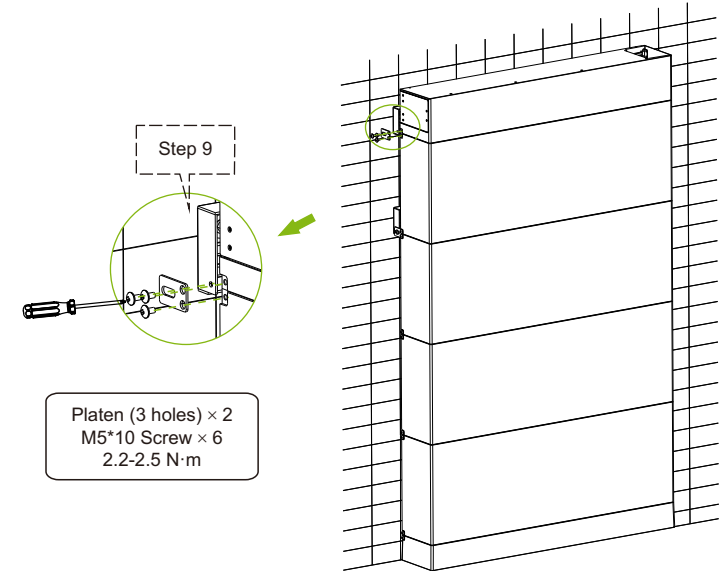
**Note!**

The holes on BMS is for secure inverter. For details, please refer to GWU-GreenE User Manual.



## 5.4 Wall Mounting

### 5.4.1 Overview

There are three schemes available for users.

#### Scheme A

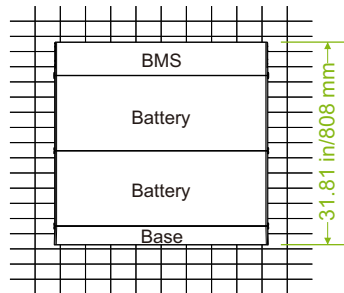

2 * Wall Bracket
2 * Expansion Bolt
2 * Tapping Screw
2 * Washer
14 * M5*10 Screw
2 * Platen (3 holes)
4 * Platen (2 holes)

Distance from the equipment:  
 To left side:  $\geq 11.81$  in./300 mm  
 To right side:  $\geq 11.81$  in./300 mm  
 To the ground :  $> 23.62$  in./600 mm (The distance is reserved for increase of battery, and a battery's height is 11.8 1 in./300 mm.)

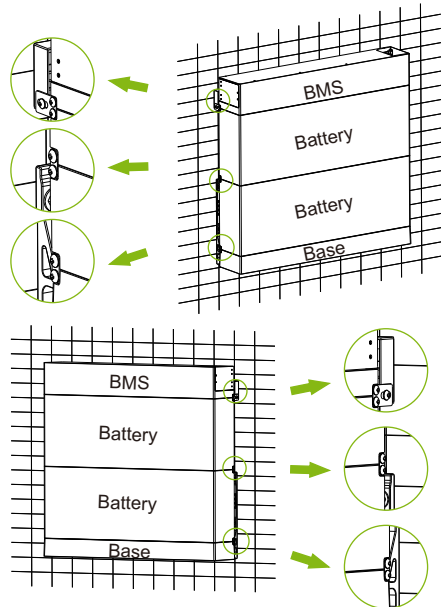

#### Scheme B

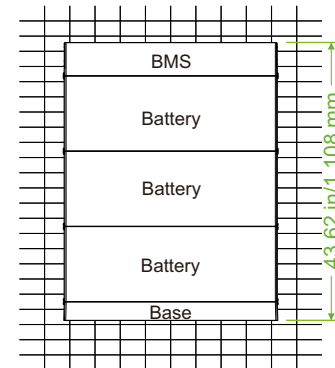

4 * Wall Bracket
4 * Expansion Bolt
4 * Tapping Screw
4 * Washer
20 * M5*10 Screw
4 * Platen (3 holes)
4 * Platen (2 holes)

Distance from the equipment:  
 To left side:  $\geq 11.81$  in./300 mm  
 To right side:  $\geq 11.81$  in./300 mm  
 To the ground :  $> 11.81$  in./300 mm (The distance is reserved for increase of battery, and a battery's height is 11.8 1 in./300 mm.)

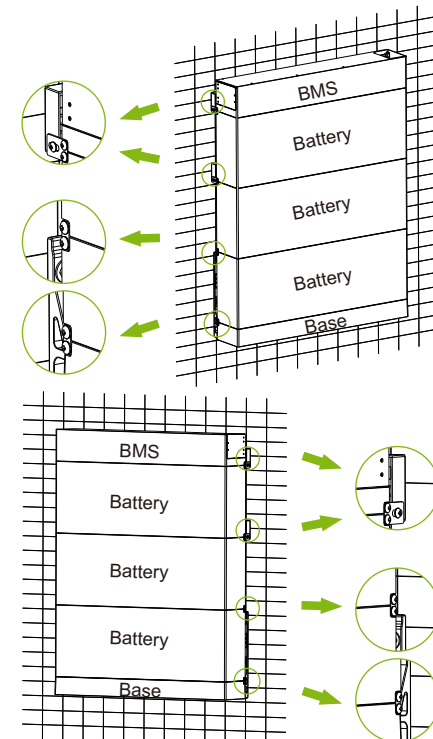

Scheme C

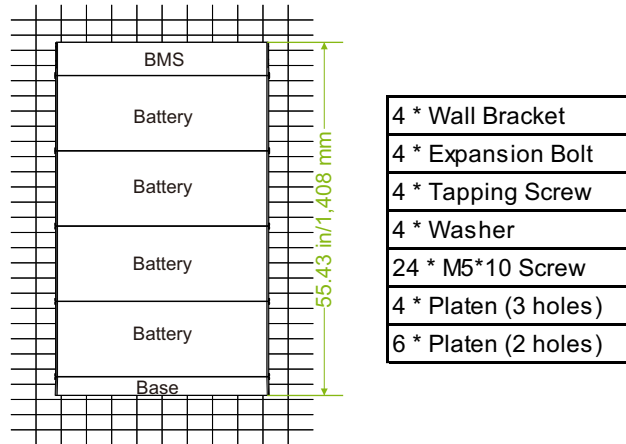

Distance from the equipment:  
 To left side:  $\geq 11.81$  in./300 mm  
 To right side:  $\geq 11.81$  in./300 mm  
 To the ground: It shall be decided according to the local regulations.

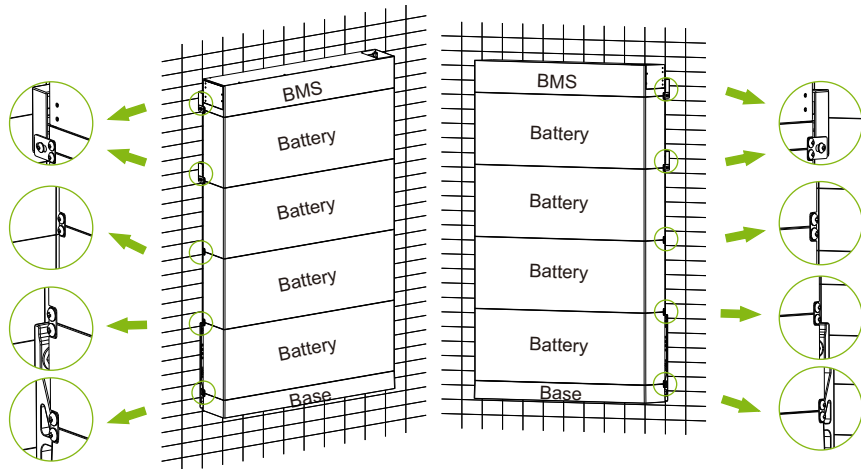

5.4.2 Step

Please reserve enough distance from the equipment to the ceiling/ground for capacity expansion.  
 Take Scheme C as an example.

Step 1: There are two ways to install Transverse Plate to Base Support due to 4 kinds of Stub Spacing, with details as follows: (a) 28 in./711.20 mm or 32 in./812.80 mm; (b) 20 in./508.00 mm or 24 in./609.60 mm.

(1) Insert Transverse Plate to Base Support;  
 (2) In case of (a), secure the Transverse Plate and Base Support using screws (2 × M5\*8 countersunk head screw), and tighten them (Tighten torque: 2.2-2.5 N·m). See figure below.

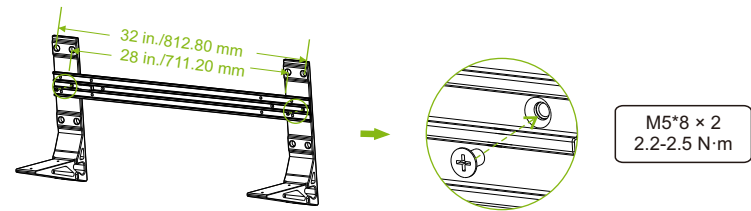

Or, in case of (b), secure the Transverse Plate and Base Support using screws (2 × M5\*8 countersunk head screw) and tighten them (Tighten torque: 2.2-2.5 N·m). See figure below.

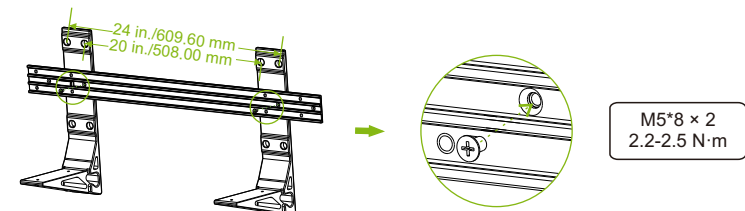

**Step 2:**

- (1) Place the assembled Transverse Plate and Base Support on the wall, look the cylindrical plastic bubble spirit level on the Transverse Plate. If the bubble isn't in the center, slightly bow it to the horizontal.
- (2) Then determine the position of holes.
- (3) Mark it with a pen.
- (4) Remove it and drill the four holes (at least 3.54 in./90 mm) by Drill (Ø 0.47 in./12 mm for concrete wall, or Ø 0.31 in./8 mm solid wood wall)

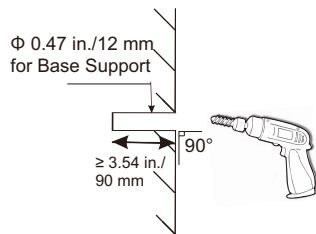
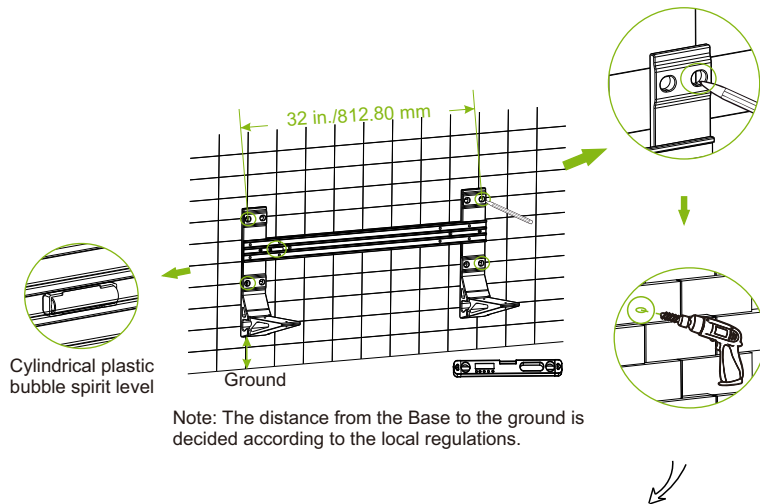

(1) Concrete Wall

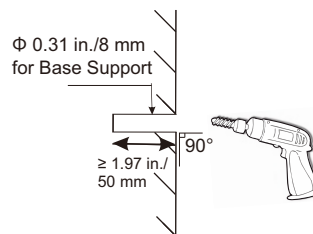

(2) Solid Wood Wall

**Note!**

The bubble spirit level on the Transverse Plate can be used as an auxiliary tool, additionally, please prepare a spirit level to measure whether the Plate is even or not.

**Step 3:**

- (1) Place the assembled Transverse Plate and Base Support to the wall (or solid wood wall);
- (2) Attach the Expansion Screw (or Self-tapping Screw M12 x 60) to the holes but be sure not to tighten;
- (3) Check whether the cylindrical plastic bubble spirit level is horizontal;
- (4) Hammer Expansion Screws with a rubber mallet (expect solid wood wall), and tighten it with torque wrench.

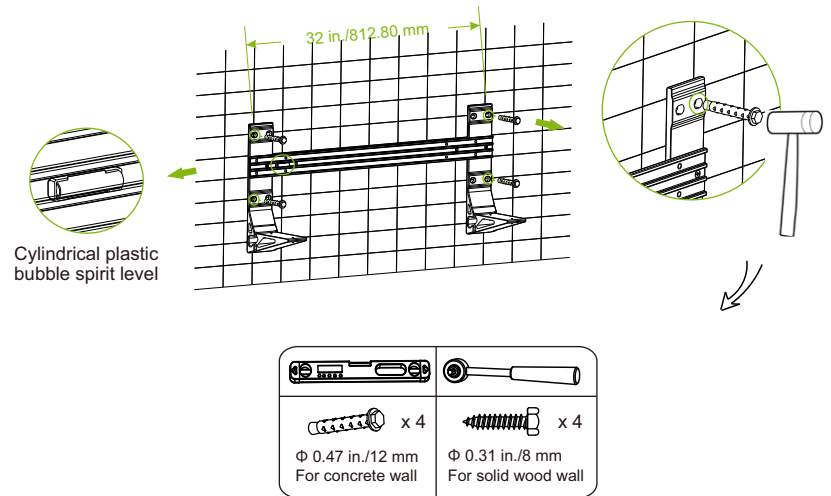

**Note!**

In case of solid wood wall, please directly tighten the screws with torque wrench instead of hammering them with rubber mallet.

Step 4: Place the base.

(1) Remove the dust cover.

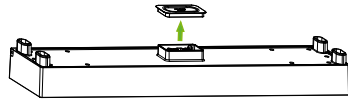

(2) Place Base on the Base Support and secure both left and right sides with screws (4 × M5\*20 countersunk screw) (Tighten torque: 2.2-2.5 N·m).

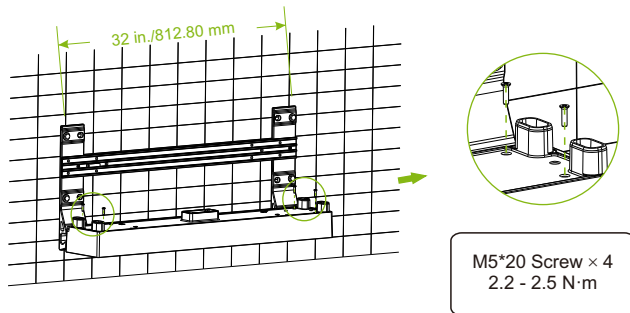

Step 5: Place Battery Module on the Base.

(1) Remove the top and bottom dust covers.

(2) Place the Battery Module on the Base.

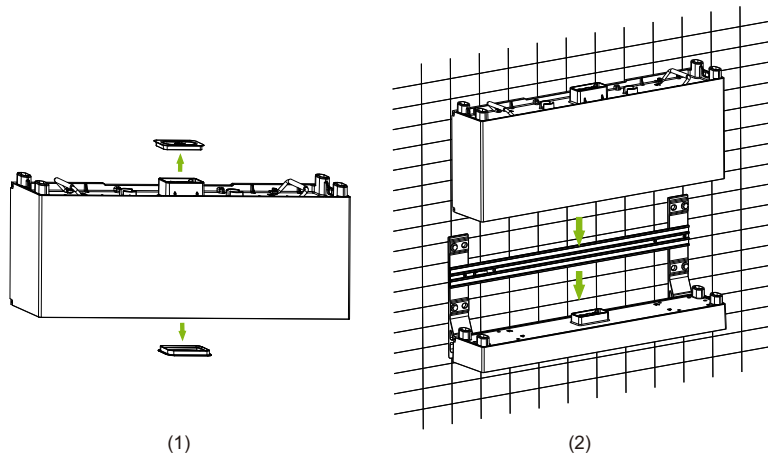

(3) Fix the Platen (2 holes) using M5 \* 10 Phillips-head screw, and secure M5\*10 screws (2) to connect Base and Battery Module (Torque: 2.2-2.5 N·m).

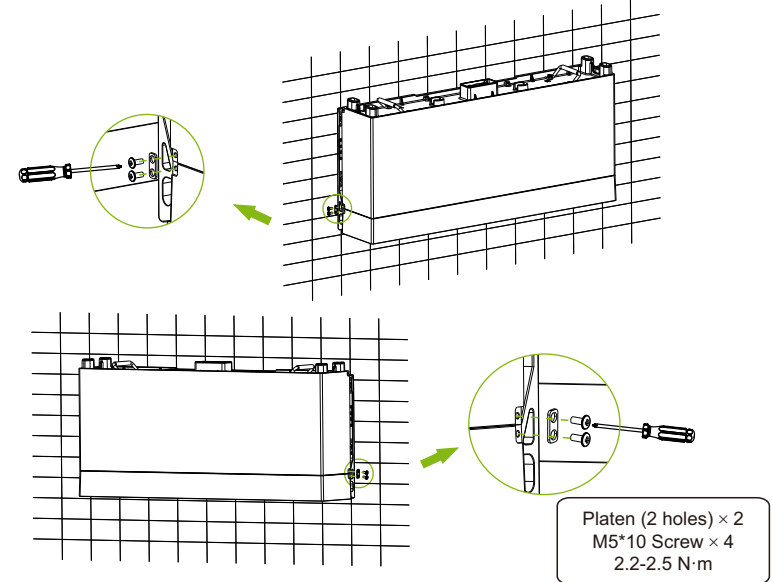

Step 6: Place two Battery Modules in turn, and secure both left and right sides with screws (4 × M5\*20 countersunk screw) (Tighten torque: 2.2-2.5 N·m). Refer to the Step 5 (3).

Please secure Platen and M5\*10 screws immediately after placing a Battery Module.

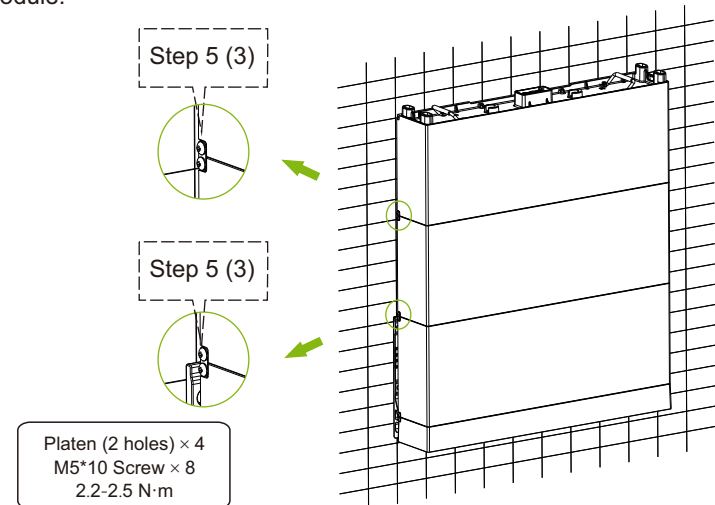

Step 7:

- (1) Attach the M5 \* 10 screw to Wall Bracket but be sure not to tighten;
- (2) Place such Wall Bracket to the wall, align its holes to the holes on the Battery Module, and use a spirit level to measure the Wall Bracket to ensure it's even;
- (3) Accurately mark the location of the Wall Bracket on both sides with a pen;
- (4) Draw circles according to the actual stub spacing;
- (5) Remove the Wall Bracket, and then drill the two holes (at least 3.54 in./90 mm) by a Drill ( $\varnothing$  0.39 in./10 mm).

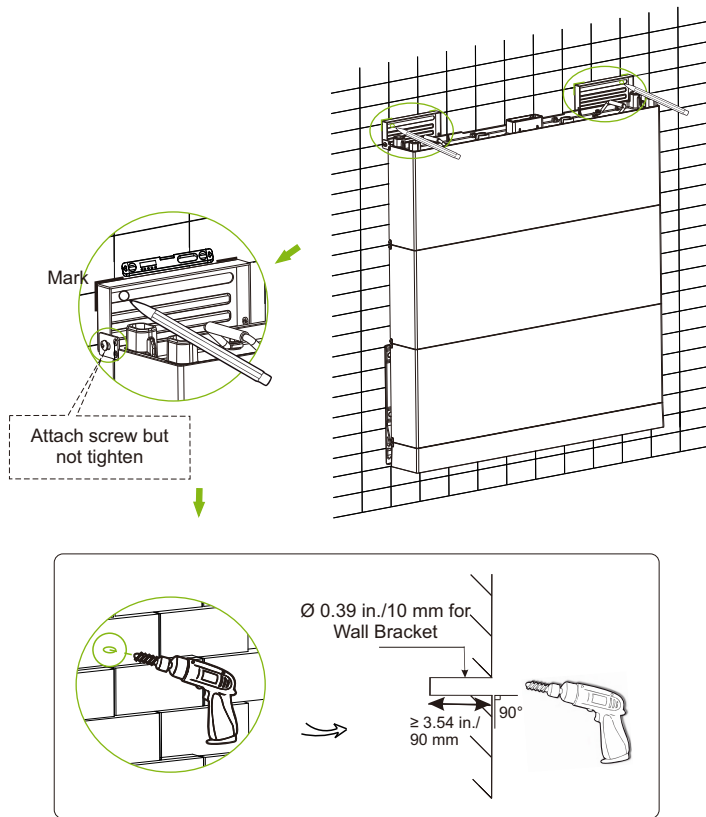

**Note!**

Electric drill dust collector is recommended.

- Step 8: Place Expansion Bolts into the two holes (the Expansion Bolt is not required in case of solid wood wall).

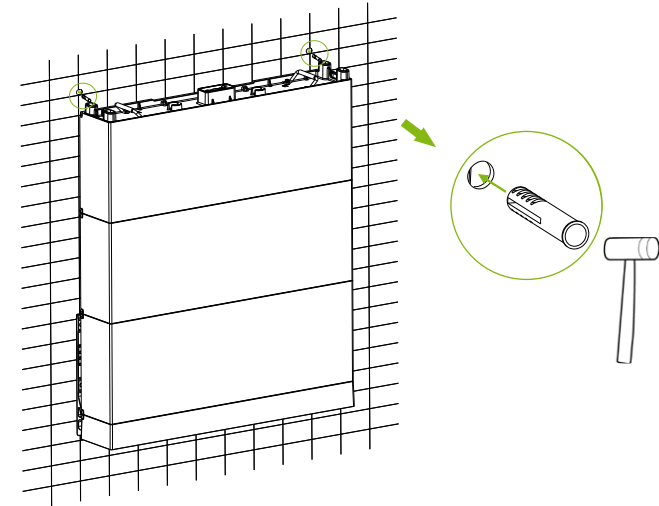

- Step 9: Place the Wall Bracket on the wall where the mark is drawn previously, and then secure the Wall Brackets on the wall using Tapping Screws and Washers.

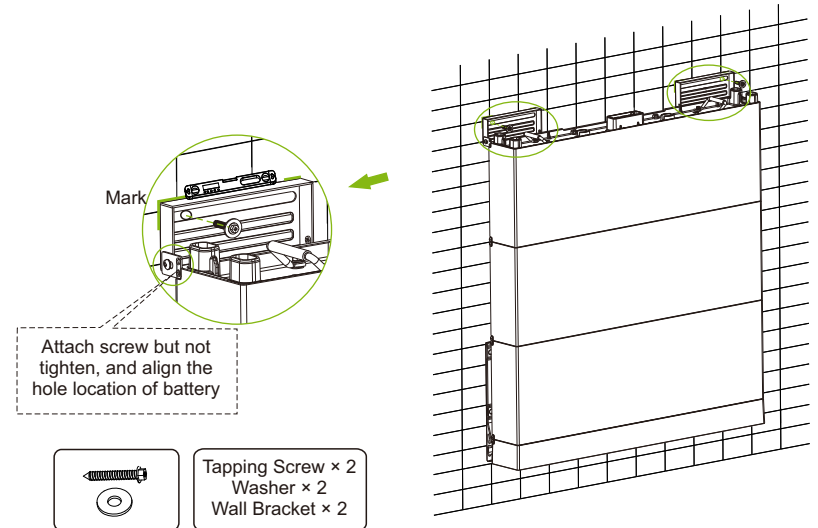

Step 10: Place the fourth battery module.

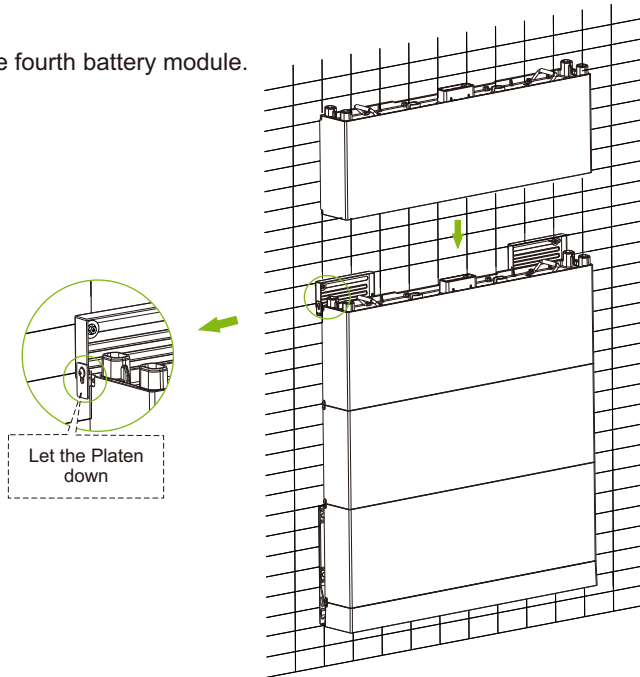

Step 11: Fix the Platen (3 holes) on both sides of Battery Module using M5 \* 10 Phillips-head screw, and then tighten M5\*10 screws (Torque: 2.2-2.5 N·m).

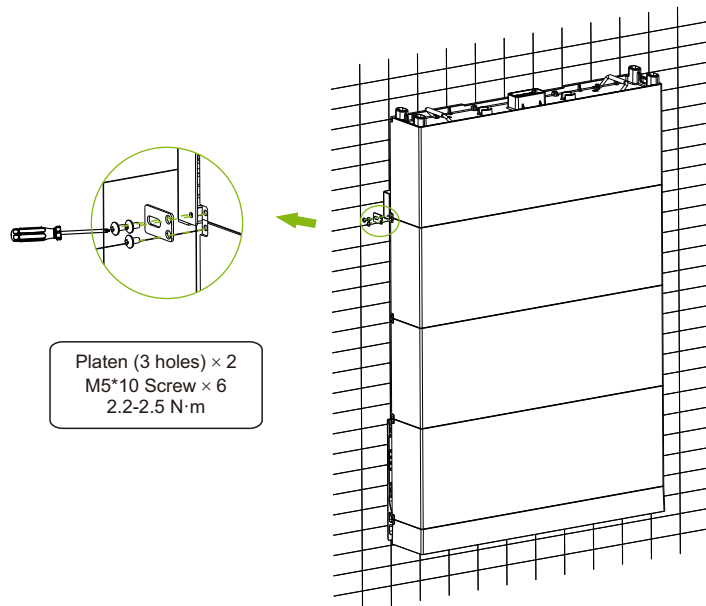

Step 12:

- (1) Attach the M5 \* 10 screw to Wall Bracket but be sure not to tighten;
- (2) Place such Wall Bracket to the wall, align its holes to the holes on the Battery Module, and use a spirit level to measure the Wall Bracket to ensure it's even;
- (3) Accurately mark the location of the Wall Bracket on both sides with a pen;
- (4) Draw circles according to the actual stub spacing;
- (5) Remove the Wall Bracket, and then drill the two holes (at least 3.54 in./90 mm) by a Drill ( $\varnothing$  0.39 in./10 mm);
- (6) Place Expansion Bolts;
- (7) Secure Wall Brackets using Tapping Screws and Washers. Refer to the Steps 7, 8, 9 and 10.

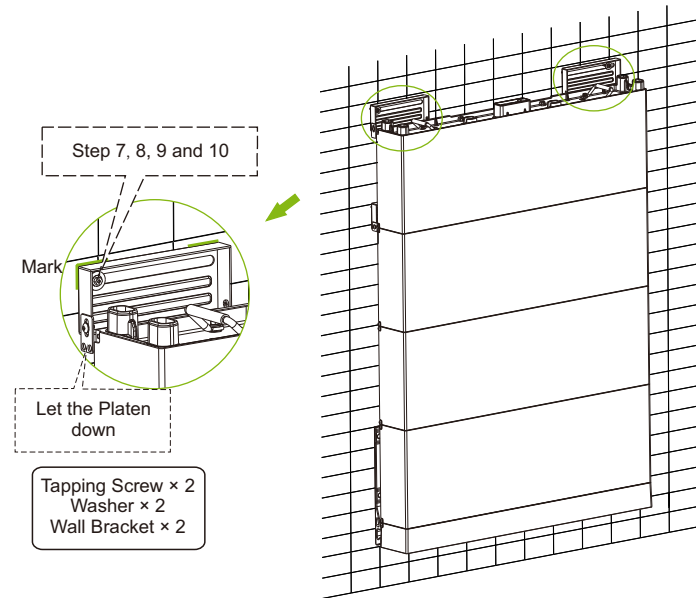

**Note!**

Electric drill dust collector is recommended.

Step 13: Place BMS on the Battery Module.

- (1) Remove the bottom dust cover.

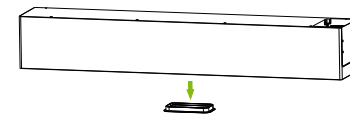

(2) Place the BMS, fix the Platen (3 holes) on both sides of Battery Module using M5 \* 10 Phillips-head screw, and then tighten M5\*10 screws (Torque: 2.2-2.5 N·m). Refer to Step 11.

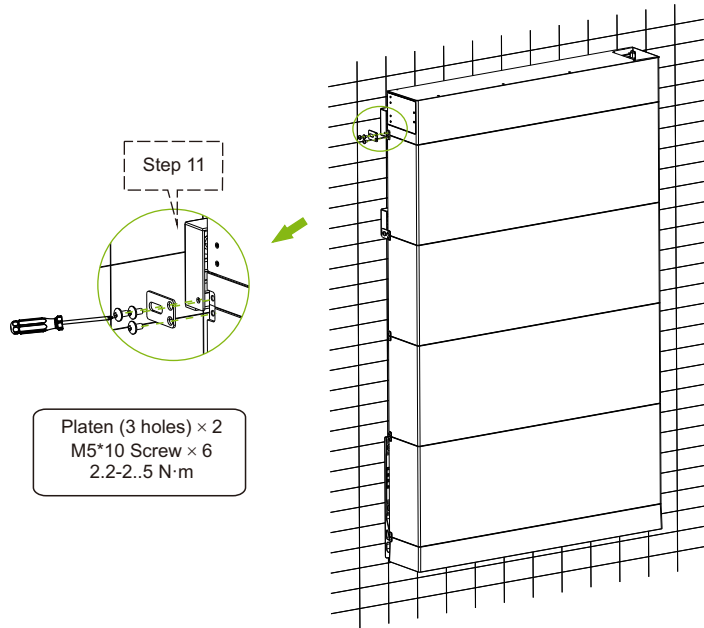

**Note!**

The holes on BMS is for secure inverter. For details, please refer to GWU-GreenE User Manual.

### 5.5 Battery Capacity Expansion

The equipment can support capacity expansion.

There are two circumstances in case the user wants to increase a battery module:

1. For floor mounting, remove the inverter before increase of battery module;
2. For wall mounting, if the distance from the equipment to the ground is enough, do not remove the inverter; otherwise, the inverter shall be removed.

## 6 Wiring

### 6.1 Making a BMS communication cable

To ensure normal operation of BMS and inverter, a BMS communication cable is required to be made before wiring.

The specific definition of the communication cable is shown as follows:

Sequence	1	2	3	4	5	6	7	8
BMS	/	GND	/	BMS_H	BMS_L	/	A1	B1

The wire order of the communication cable is as follows:

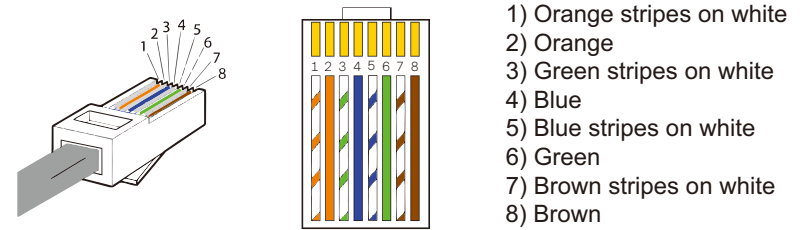

Note: The BMS communication cable shall have a shield layer.

## 6.2 Wiring

### Note!

Before wiring, the guards (if any) shall be removed from connectors. The parts where BMS needs to wire are as follows:

Before wiring,

1. Unscrew the cap at BMS clockwise;
2. Unscrew the screws at BAT+ and BAT- respectively.

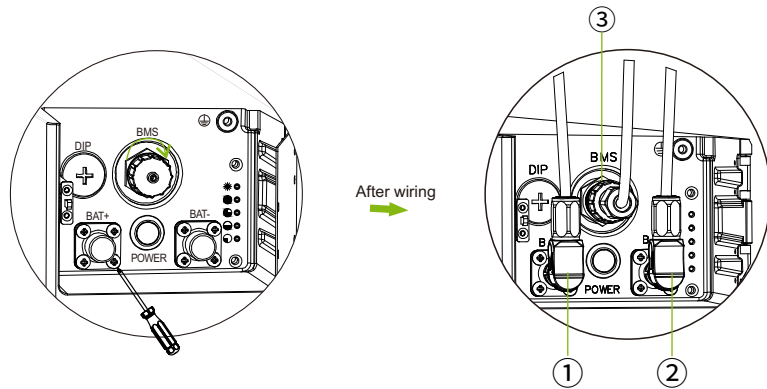

Connect 3 wires of the inverter to the corresponding sockets

Item	Description
①	Insert the orange power line into the orange socket
②	Insert the black power line into the black socket
③	Screw the communication line into the communication socket

### Note!

Don't violently remove cables when they are locked.

## 7 Commissioning

### 7.1 Commissioning

Verify the model number of each battery module to ensure that they are all the same model.

Step	Description
①	After finishing BMS's wiring, press the left side door panel
②	Open the air switch's guard and toggle switch, to ensure that the inverter does charge to the battery
③	Press the right side door panel
④	Press the button for 1 to 2 sec, and then the system starts

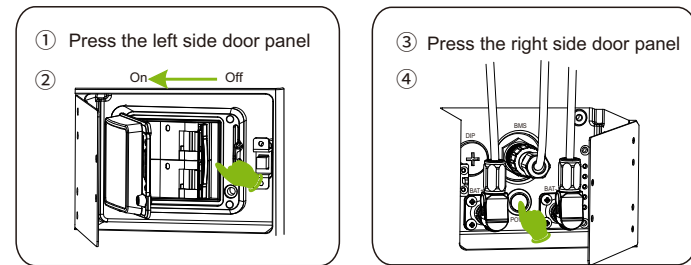

### Note!

- Frequently pressing the POWER button may cause a system error.
- Wait at least 10 seconds after pressing the POWER button prior to making another attempt.

Our equipment can provide Black Start capability, meaning that our energy storage inverter and battery can continue to run even if the power grid and photovoltaic panel are out of service. The startup procedure for Black Start is set forth: Press the POWER button and hold it for 20 sec; release the button after the four SOC indicators (1<sup>st</sup> and 4<sup>th</sup> indicators, 2<sup>nd</sup> and 3<sup>rd</sup> indicators) flash blue alternately; at this point, it will show its current battery charge and enter the Black Start status.

### Note!

We do not recommend the use of Black Start as it may cause the communication port to be charged, resulting in an electric shock.



## 7.2 Status Indicators

### 7.2.1 BMS (GWU-BAT-BMS)

The power indicators show the current battery percentage, with details as show in the figure below.

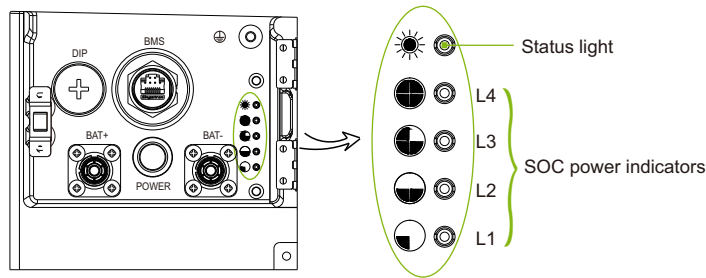

Description of Status Light	
Power Off	Status light and SOC power indicators are off.
Working	When charging, status light will remain on solid green light; when discharging, status light will flash green every 0.5 sec.
Idle State	Status light begins green for 1 sec and turns off for 4 sec; all SOC power indicators are off.
Fault	Status light begins solid red; 10 mins later, the status light will flash red for 1 sec and turn off for 4 sec, and the SOC power indicators will flash to indicate a malfunction (for details, refer to the following table).
Upgrade	Status light flashes green, red and yellow; SOC power indicators flash blue every 0.2 sec.
Black Start	Press the POWER button and hold it for 20 sec; release the button after the four SOC indicators (1st and 4th indicators, 2nd and 3rd indicators) flash blue alternately, and then enter an Black Start status.

Fault	SOC power indicator				Fault code
	L4	L3	L2	L1	
Secondary cell voltage (overvoltage & undervoltage of cell and pack)	Off	Off	Off	F1	1
Temperature fault of secondary cell (overtemperature and undertemperature during charge and discharge)	Off	Off	F1	Off	2
Relay fault (disconnection and connection of relay's anode and cathode)	Off	F1	Off	Off	4
Insulation fault	Off	F1	Off	F1	5
Communication failure between BMS and battery module(s)	F1	Off	Off	Off	8
Communication failure between the 1st battery and 2nd battery	F1	Off	Off	F1	9
Communication failure between the 2nd battery and 3rd battery	F1	Off	F1	Off	10
Communication failure between the 3rd battery and 4th battery	F1	Off	F1	F1	11
Overcurrent fault (overcurrent during charge and discharge)	Off	Off	F1	F1	3
Short-circuit fault	Off	F1	F1	Off	6
Hardware failure of other circuit (self-test)	Off	F1	F1	F1	7
Battery failure (disconnection, short-circuit and internal fault of battery)	F1	F1	Off	F1	13
Sensor fault	F1	F1	F1	Off	14
Inverter communication timeout	F1	F1	F1	F1	15

Note: F1 indicates flashing once.

## 7.3 Shutting Down GWU-BAT System

To shut down the system, follow the steps described below:

Step	Description
①	Press the right side door panel
②	Press the button for 1 to 2 sec. In the meantime, the status light is green, and the SOC power lights flash in squence starting with the light farthest from the status light and ending with the light closest to the status light
③	Press the left side door panel
④	Open the air switch's guard and toggle switch

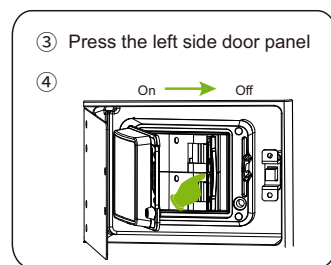
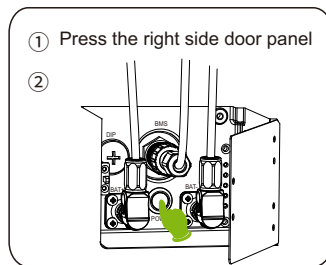

## 8 Troubleshooting

### 8.1 Troubleshooting

Check the previous indicators to determine the status of the GWU-BAT system. In case of the following circumstances, e.g. voltage or temperature exceeds a limit, a warning state will be triggered.

GWU-BAT system's BMS periodically reports its operating state to the inverter. When the GWU-BAT system exceeds the specific limits, it will enter into a warning state.

When a warning is reported, the inverter will stop work immediately.

Determine the cause of warning by using the monitoring software on the inverter. The possible error messages are as follows:

Error	Description	Diagnosis & Solution
BMS_External_Err	External fault of BMS	Unable to establish communication with inverter. <ul style="list-style-type: none"> <li>Restart BMS;</li> <li>Contact the Company's after-sales personnel.</li> </ul>
BMS_Internal_Err	Internal fault of BMS	Unable to establish communication among batteries. <ul style="list-style-type: none"> <li>Restart BMS;</li> <li>Check if the connection among batteries is normal;</li> <li>Contact the Company's after-sales personnel.</li> </ul>
BMS_OverVoltage	BMS overvoltage	Overvoltage of single battery. <ul style="list-style-type: none"> <li>Contact the Company's after-sales personnel.</li> </ul>
BMS_LowerVoltage	BMS undervoltage	Undervoltage of single battery. <ul style="list-style-type: none"> <li>Battery is forced to charge through inverter;</li> <li>Contact the Company's after-sales personnel.</li> </ul>
BMS_ChargeOverCurrent	Overcurrent charging of BMS	Overcurrent charging of BMS. <ul style="list-style-type: none"> <li>Restart BMS;</li> <li>Contact the Company's after-sales personnel.</li> </ul>
BMS_DischargeOverCurrent	Discharge overcurrent of BMS	Discharge overcurrent of BMS. <ul style="list-style-type: none"> <li>Restart BMS;</li> <li>Contact the Company's after-sales personnel.</li> </ul>

Error	Description	Diagnosis & Solution
BMS_TemHigh	High temperature of BMS	The temperature of BMS is too high. <ul style="list-style-type: none"> <li>Let BMS cool down to normal temperature and restart;</li> <li>Contact the Company's after-sales personnel.</li> </ul>
BMS_TemLow	Low temperature of BMS	The temperature of BMS is too low. <ul style="list-style-type: none"> <li>Warm up BMS and restart;</li> <li>Contact the Company's after-sales personnel.</li> </ul>
BMS_CellImbalance	Cell imbalance of BMS	Inconsistency of battery. <ul style="list-style-type: none"> <li>Restart BMS;</li> <li>Contact the Company's after-sales personnel.</li> </ul>
BMS_Hardware_Protect	Hardware protection of BMS	Hardware protection of BMS. <ul style="list-style-type: none"> <li>Restart BMS;</li> <li>Contact the Company's after-sales personnel.</li> </ul>
BMS_Circuit_Fault	Circuit fault	Circuit fault of BMS. <ul style="list-style-type: none"> <li>Restart BMS;</li> <li>Contact the Company's after-sales personnel.</li> </ul>
BMS_Insulation_Fault	Insulation fault	Insulation fault of BMS. <ul style="list-style-type: none"> <li>Restart BMS;</li> <li>Contact the Company's after-sales personnel.</li> </ul>
BMS_VoltSensor_Fault	Voltage sensor fault	Voltage sampling fault of BMS. <ul style="list-style-type: none"> <li>Restart BMS;</li> <li>Contact the Company's after-sales personnel.</li> </ul>
BMS_TempSensor_Fault	Temperature sensor fault	Temperature sampling fault of BMS. <ul style="list-style-type: none"> <li>Restart BMS;</li> <li>Contact the Company's after-sales personnel.</li> </ul>
BMS_TempSensor_Fault	Current sensor fault	Current sampling fault of BMS. <ul style="list-style-type: none"> <li>Restart BMS;</li> <li>Contact the Company's after-sales personnel.</li> </ul>
BMS_Relay_Fault	Relay fault	Relay contact adhesion fault of BMS. <ul style="list-style-type: none"> <li>Restart BMS;</li> <li>Contact the Company's after-sales personnel.</li> </ul>

Error	Description	Diagnosis & Solution
BMS_Type_Unmatch	BMS type matching error	Different type of BMS. <ul style="list-style-type: none"> <li>Restart BMS;</li> <li>Contact the Company's after-sales personnel.</li> </ul>
BMS_Version_Unmatch	BMS version matching error	Different type of BMS. <ul style="list-style-type: none"> <li>Restart BMS;</li> <li>Contact the Company's after-sales personnel.</li> </ul>
BMS_Manufacturer_Unmatch	BMS manufacturer matching error	Different type of BMS. <ul style="list-style-type: none"> <li>Restart BMS;</li> <li>Contact the Company's after-sales personnel.</li> </ul>
BMS_SW&HW_Unmatch	Software and hardware mismatch error of BMS	Different type of BMS. <ul style="list-style-type: none"> <li>Restart BMS;</li> <li>Contact the Company's after-sales personnel.</li> </ul>
BMS_M&S_Unmatch	BMS and battery module mismatch error	Different type of BMS. <ul style="list-style-type: none"> <li>Restart BMS;</li> <li>Contact the Company's after-sales personnel.</li> </ul>
BMS_CR_Unresponsive	Charging request not responded	Inverter does not respond the charging request. <ul style="list-style-type: none"> <li>Restart BMS or inverter;</li> <li>Contact the Company's after-sales personnel.</li> </ul>
S_Software_Protect	Software protection of battery module	Software protection of battery module. <ul style="list-style-type: none"> <li>Restart BMS;</li> <li>Contact the Company's after-sales personnel.</li> </ul>
BMS_536_Fault	536 fault of BMS	BMS voltage sampling fault. <ul style="list-style-type: none"> <li>Restart BMS;</li> <li>Contact the Company's after-sales personnel.</li> </ul>
BMS_Selfchecking_Fault	Self-test fault of BMS	Self-test fault of BMS. <ul style="list-style-type: none"> <li>Restart BMS;</li> <li>Contact the Company's after-sales personnel.</li> </ul>
BMS_Tempdiff_Fault	Temperature different fault	BMS temperature varies greatly. <ul style="list-style-type: none"> <li>Restart BMS;</li> <li>Contact the Company's after-sales personnel.</li> </ul>

Error	Description	Diagnosis & Solution
BMS_Break	Disconnection fault of BMS	BMS sampling fault. <ul style="list-style-type: none"> <li>Restart BMS;</li> <li>Contact the Company's after-sales personnel.</li> </ul>
BMS_Flash_Fault	Flash fault of BMS	Memory chip fault. <ul style="list-style-type: none"> <li>Restart BMS;</li> <li>Contact the Company's after-sales personnel.</li> </ul>
BMS_Precharge_Fault	BMS precharge fault	External short circuit of BMS. <ul style="list-style-type: none"> <li>Check the external connection and restart BMS;</li> <li>Contact the Company's after-sales personnel.</li> </ul>
BMS_AirSwitch_Break	Disconnection of switch break of BMS	Disconnection of switch break of BMD. <ul style="list-style-type: none"> <li>Restart BMS;</li> <li>Contact the Company's after-sales personnel.</li> </ul>

## 9 Decommissioning

### 9.1 Dismantling the Battery

Shutting down the battery unit

- Disconnect the cables between the BMS and inverter
- Disconnect the series wiring terminal on the battery
- Disconnect the cables

### 9.2 Packing

Pack the BMS and battery modules in the original packaging.

If the original packaging is no longer available, use an equivalent carton or box that meets the following requirements:

- Suitable for loads over 154.32 lbs/70.00 kg
- Properly closed and sealed

## 10 Maintenance

-If the ambient temperature for storage is -4°F~-122°F/-20°C~50°C, recharge the batteries at least once every 3 months.

-If the ambient temperature for storage is 32°F~104°F/0°C~40°C, recharge the batteries at least once every 12 months.

- If the battery(ies) has(have) not been used for more than 9 months, the battery(ies) must be charged to at least SOC 50 % each time.

- For the first installation, the interval among manufacture dates of batteries shall not exceed 3 months.

- If a battery is replaced or added for capacity expansion, each battery's SOC should be consistent. The max. SOC difference should be between  $\pm 5\%$ .

- If users want to increase their battery system capacity, please ensure that the SOC of the existing system capacity is about 40%. The manufacture date of the new battery shall not exceed 6 months; in case of exceeding 6 months, please charge the new battery to around 40%.

## 11 Disclaimer

Greenworks will service the warranty when it is installed and used as described in the Manual. Otherwise, it will not be covered by warranty.

In case there is any direct or indirect damage or defect caused by the following circumstances, Greenworks will not assume any warranty responsibility.

- Force majeure (flooding, lightning strike, overvoltage, fire, thunderstorm, flooding etc.);
- Improper or noncompliant use;
- Improper installation, commissioning, start up or operation (contrary to the guidance detailed in the installation manual supplied with each product);
- Inadequate ventilation and circulation resulting in minimized cooling and natural air flow;
- Installation in a corrosive environment;
- Damage during transportation;
- Unauthorized repair attempts;
- Failure to adequately maintain the equipment. An on-site inspection by a qualified technician is possible following 120 months of continuous use warranty claims made beyond 120 months from date of commissioning may be declined if it cannot be demonstrated that the equipment has been adequately maintained;
- External influence including unusual physical or electrical stress (power failure surges, inrush current, etc.);
- Use of an incompatible inverter or devices; and
- Connect to other brands inverters without authority from our Company.

**WARNING**

This equipment has been tested and found to comply with the limits for a Class B digital device, pursuant to Part 15 of the FCC Rules. These limits are designed to provide reasonable protection against harmful interference when the equipment is operated in a residential installation. This equipment generates, uses, and can radiate radio frequency energy and if not installed and used in accordance with the instruction manual may cause harmful interference to radio communications. However, there is no guarantee that interference will not occur in a particular installation. If this equipment does cause harmful interference to radio or television reception, which can be determined by turning the equipment off and on, the user is encouraged to try to correct the interference by one or more of the following measures:

- Reorient or relocate the receiving antenna.
- Increase the separation between the equipment and receiver.
- Connect the equipment into an outlet on a circuit different from that to which the receiver is connected.
- Consult the dealer or an experienced radio TV technician for help.

Notice: The changes or modifications not expressly approved by the party responsible for compliance could void the user's authority to operate the equivalent.

# Warranty Registration Form



**For Customer (Compulsory)**

Name ..... Country .....

Phone Number ..... Email .....

Address .....

State ..... Zip Code .....

Product Serial Number .....

Date of Commissioning .....

Installation Company Name .....

Installer Name ..... Electrician License No. ....

**For Installer**

Module ( If Any )

Module Brand .....

Module Size(W) .....

Number of String ..... Number of Panel Per String .....

Battery ( If Any )

Battery Type .....

Brand .....

Number of Battery Attached .....

Date of Delivery ..... Signature .....

Please visit our warranty website: <https://access.greenworkspower.com/#/warranty> to complete the online warranty registration.

