



## 48" ECLIPSE UNDERMOUNT SINK

- METAL = 14 GAUGE 48OZ PURE COPPER
- MODEL = ECLIPSE UNDERMOUNT - 48 INCH
- FINISH = SELECT LUXURY METAL FINISH
- DRAIN = RIGHT OFFSET - KITCHEN 3-1/2" SIZE

- OVERALL SIZE  
48" x 20-1/2" x 9"
- BOWL SIZE  
46" x 17-1/2" x 9"
- COUNTER OPENING  
46" x 18-1/2" x 9"

TOP VIEW

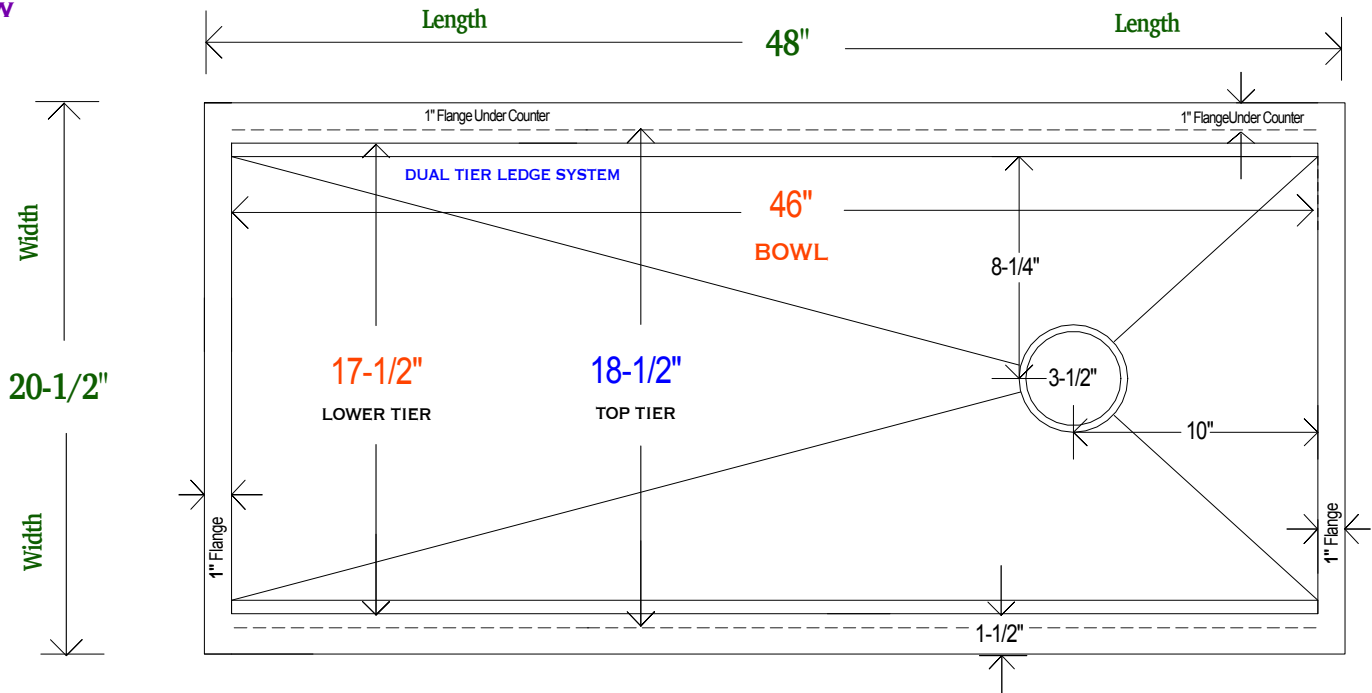

SIDE VIEW

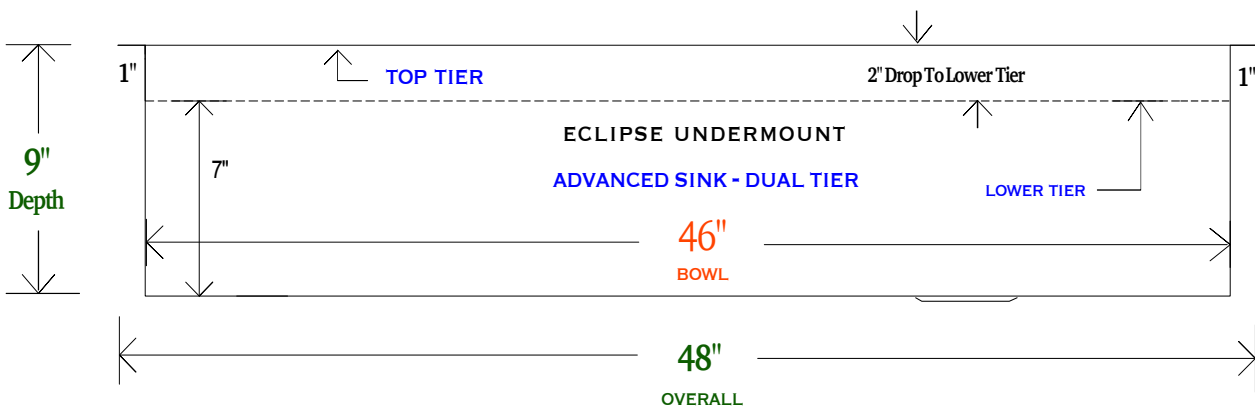

LEDGE PROFILE

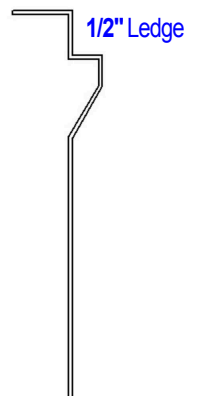



**ADVANCED SINK ACCESSORIES**

**1** - SELECT (NO PACKAGE) | **2** - HOME CHEF | **3** - PRO CHEF | **4** - ELITE CHEF

**1 - 4**

SELECT



PACKAGE

METAL FINISH  
PURE COPPER

BOARDS FINISH  
AMBER BAMBOO

ACCESSORY FIT  
ADVANCED SINK

STANDARD -   
17.5" LEDGE DISTANCE

CUSTOM -

DRYING RACK

12 INCH -

15 INCH -

18 INCH -

DROP IN BOWL

12 INCH -

15 INCH -

18 INCH -

DROP IN STRAINER

12 INCH -

15 INCH -

18 INCH -

BAKING SHEET

12 INCH -

15 INCH -

18 INCH -

CUTTING BOARD

12 INCH -

15 INCH -

18 INCH -

MIXING BOARD

ONE SIZE -

12 INCHES WIDE  
5 QUART BOWL

TRIPLE SERVE

ONE SIZE -

9 INCHES WIDE  
3 CONTAINERS

SEGMENTED COVER

ONE PIECE -

TWO PIECE -

THREE PIECE -

SPONGE CADDY

3 INCH -  6 INCH -

BASIN GRATE

SINGLE -  SEGMENTED -

INSTALL COMPONENTS

DISPOSAL DRAIN -

STRAINER DRAIN -

PRO DISPOSAL PACK -

COPPER CAULKING -

STAINLESS SILICONE -

CLEANING & CARE PACK -

UNDER SINK STORAGE -

SELECTED FAUCET(S) -

NOTES: N/A



### CABINET & COUNTERTOP GUIDE FOR THE ECLIPSE SINK

THE ECLIPSE DUAL-TIER SINK IS INSTALLED IN THE CABINET PRIOR TO THE COUNTER TEMPLATING.

A SUPPORT STRUCTURE, (CLEAT SYSTEM OF WOOD FRAME), WILL NEED TO BE CONSTRUCTED AND MOUNTED INSIDE THE BASE CABINET(S) AND RECESSED 1/16" FROM THE TOP. FOR 24" DEEP INSET CABINETS INSTALLED AGAINST A WALL THE CABINET MUST BE PULLED 1" AWAY FROM THE WALL.

#### CLIPS ARE NOT NECESSARY FOR INSTALLATION

- 1) A SUPPORT FRAME (CLEAT SYSTEM) WILL NEED TO BE BUILT AND INSTALLED INTO THE CABINET(S). THIS FRAME WILL SUPPORT THE WEIGHT OF THE ECLIPSE SINK.
- 2) CONSTRUCT THE SUPPORT FRAME SO THAT THE INSIDE DIMENSIONS ARE 1/2" LARGER THAN THE BASIN'S INSIDE DIMENSIONS.
- 3) ATTACH THE SUPPORT FRAME TO THE INTERIOR WALLS OF THE CABINET SUPPORT FRAME MUST BE INSTALLED 1/16" LOWER THAN THE TOP OF THE CABINET. INSTALLED, THE TOP OF THE ECLIPSE FLANGES WILL BE FLUSH WITH THE TOP OF THE CABINET. USE A LEVEL TO ENSURE THAT THE SUPPORT FRAME IS INSTALLED LEVEL IN THE CABINET.
- 4) CAREFULLY PLACE THE ECLIPSE SINK INTO THE CABINET BY RESTING THE FLANGES ON THE SUPPORT FRAME. ALL FOUR FLANGES SHOULD REST UPON THE SUPPORT FRAME.
- 5) USE A LEVEL TO ENSURE THAT THE FLANGES ARE LEVEL.
- 6) THE TOP OF THE FLANGES SHOULD BE FLUSH WITH THE TOP OF THE CABINET.

### COUNTER TOP INSTALLATION

THE FRONT TO BACK CUTOUT DIMENSION MUST BE EXACTLY 18-1/2".

THE MAXIMUM RECOMMENDED CORNER RADIUS IS 3/8".

\*PLEASE REFER TO COUNTERTOP MANUFACTURE WARRANTED MINIMUMS\*

**THE FINISHED COUNTERTOP DOES NOT COMPLETELY COVER THE ECLIPSE SINK FLANGES.**

1/2" WILL BE EXPOSED ON THE FRONT AND BACK FLANGES (THIS IS KNOWN AS A REVEAL). CREATING THIS REVEAL ALLOWS FOR THE ACCESSORIES TO SLIDE ACROSS THE UPPER TIER.

1. COVER WHAT WILL BE THE EXPOSED 1/2" OF THE FRONT AND BACK FLANGES WITH PAINTERS TAPE FOR EASY CLEANING OF EXCESS SILICONE.
2. APPLY A GENEROUS BEAD OF SILICONE TO THE UN-TAPED PART OF THE FLANGE.
3. SET THE COUNTERTOP AND POSITION IT PROPERLY SO YOU HAVE 1/2" REVEAL ON THE FRONT AND BACK FLANGES AND 1/4" REVEAL ON THE LEFT AND RIGHT FLANGES. PRESS COUNTERTOP DOWN ONTO THE FLANGE. THE SILICONE SHOULD FILL ANY GAPS.
4. WIPE EXCESS SILICONE OFF OF EXPOSED FLANGE.
5. WAIT ONE HOUR AND REMOVE TAPE. THIS WILL ENSURE THERE IS A CLEAN FLANGE, FREE FROM SILICONE. WHICH WILL ENABLE THE WORKSTATION ACCESSORIES TO SLIDE FREELY.

CALL HAVENS | 407-456-7071 >>>