

OZARKÉ

INSTRUCTION MANUAL

OZARKÉ

Thank you for shopping with Ozarké, we really appreciate your business. Our goal is to provide an excellent customer service before, during and after delivery. We've included a guide on how to install this light, should you require additional assistance please feel free to email us at info@ozarke.com and one of our customer service reps will reach out to assist you.



WARNING!

1. Do not use the power supply beyond the specified range (100-240V,50Hz).
2. Avoid scratching the surface and wires of the lamp during installation.
3. Do not install the lamp outdoors.
4. The lamp should not be close to corrosive chemical objects or gases.
It should not be washed with water. It can only be wiped with a clean soft cloth.

OZARKÉ

Installation Instructions

Tools and Materials You'll Need:

- Metal Base
- Metal base + Wire
- 5 screws
- Allen key tool
- Non-slip pads
- Adapter cord
- Remote

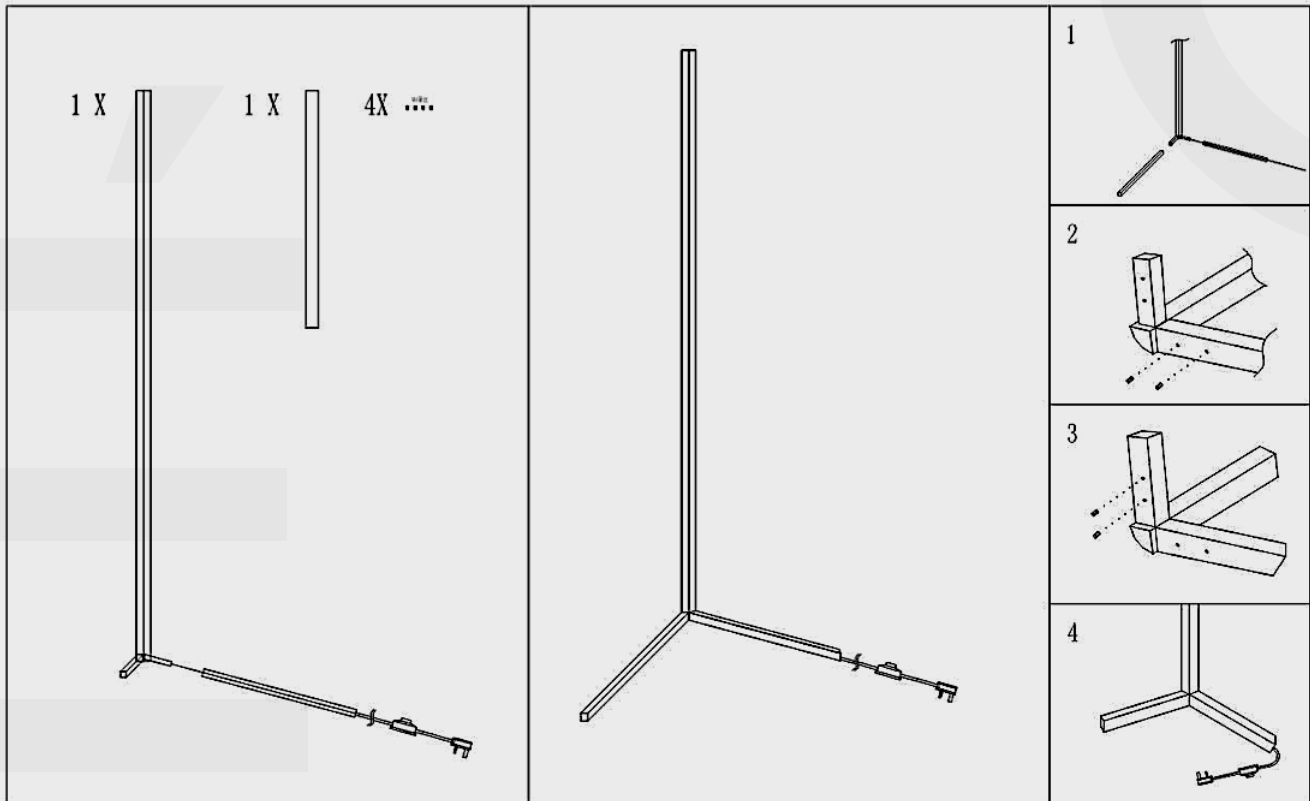

Instructions

Remove lamp pieces from package gently.

1	Connect tool A and B to LED bar.
2	Use tool C and D to secure base of the lamp.
3	Repeat step 2. Attach tool E to base of lamp.
4	Carefully attached tool F to lamp cord and plug-in

Installation Instructions

Touch Symphony Controller Instruction Manual

Basic parameters:

- **Working voltage:** 5-24V
- **Effect mode:** >300 model
- **Control points:** Max up to 1024 pixels points
- **Remote control distance:** Mini version 30 meter
- **Battery model:** 2 pcs No.7 (3A) batteries (remote control battery)

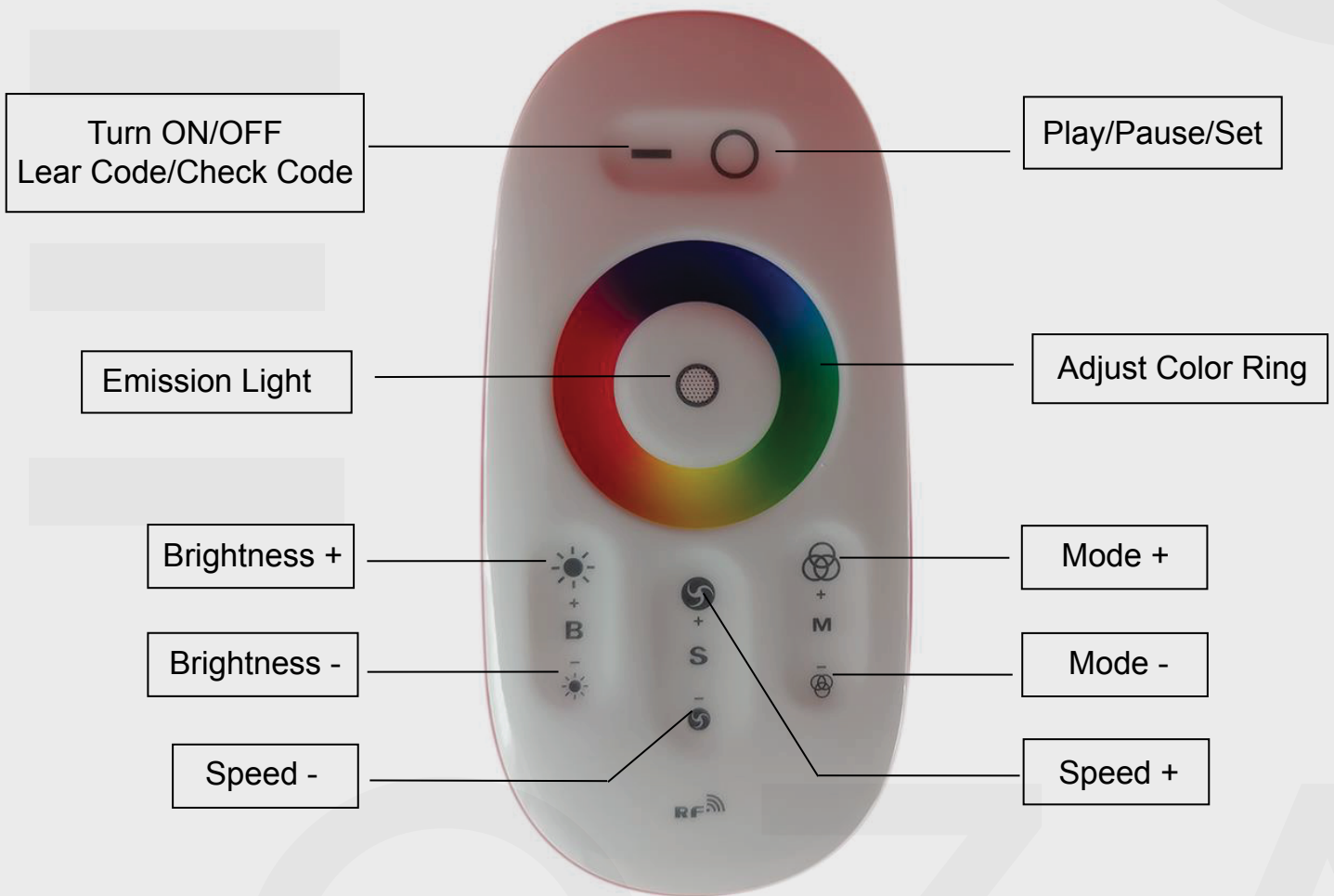

Installation Instructions

Remote Control Button Function

ON/OFF:

- Short press the on/off button to cycle the controller to switch on and off.

Play/Pause:

- Press the pause button in dynamic mode, and the light will stop moving
- Press the color ring and then press the play button, the control panel will enter the auto play mode
- Long press the Play/Pause button for more than 5S to enter the setting mode, and the light strip will appear white. At this time, you can adjust the line sequence and number of the light strip.

Speed+

- Short press in dynamic mode can increase the speed of light transformation
- Under the setting state, press the button to increase the number of lights.

Speed-

- Short press in dynamic mode can reduce the speed of light conversion
- Under the setting state, press the button to reduce the number of lamp strips.

Brightness + / -:

- Add and subtract the brightness of the light;
- Press the button in the setting state to adjust the line sequence of the lamp belt

Mode+/-:

- The mode can be looped up and down

Adjust color ring:

- At any state, press or slide the color ring to adjust the color of the lamp strip to the corresponding color

Autoplay function:

- Press the "Color Adjustment Ring" and then the "Play" button to loop from the first effect

Adjustment point function:

- Press the "On/Off" button to shut down the machine. In the shutdown state, long press the "Play/Pause" button to enter the setting state (white light will be on). At this time, press the "Speed +" and "Speed -" button to adjust the points

Line sequence adjustment function:

- Press the "On/Off" button to shut down the machine. Under the shutdown state, long press the "Play/Paid" button to enter the setting state (white light will be on). At this time, press "Brightness +" and "Brightness -" to adjust the line order

Remote control code/clear code function:

- In any case, long press the "on/off" button to carry out a cycle of code clearing and code checking of the controller. When the code is successful, the blue light flashes quickly. At this time, only the remote control can control the controller. When code clearing is successful, the yellow light of the light bar will flash slowly. At this time, all the same remote controls can control the controller, which is the pass code state (the factory default pass code).

Wiring diagram:

