

Ride Vision 1 self Installation Manual v3

TABLE OF CONTENTS

1. **Unboxing and Material Overview**
 - a. **Box content**
 - b. **Required Tools**
 - c. **Additional Items**
 - d. **Optional Items**
2. **Preparing for installation**
 - a. **Adhesive guide**
 - b. **Critical component location guide**
3. **Front Camera Installation**
4. **Rear Camera Installation**
5. **GPS Installation**
6. **Speed sensor Installation**
7. **Alert Indicators Installation**
8. **Main Unit (ECU) Installation**
9. **Verification**
 - a. **System power**
 - b. **Speed sensor**
10. **App**
 - a. **Registration**
 - b. **Activation**
 - c. **Calibration**

Thank you for purchasing Ride Vision 1.

Please follow the steps below in order to install, activate and successfully calibrate your system.

In this manual, we will cover the process, parts, and accessories required for the successful installation of Ride Vision 1.

The order of this installation is important, please be sure to follow it.

Safety notice:

- Below are the steps for Ride Vision 1 installation, Failure to follow these steps could result in system damage or malfunction.
- Caution: If the motorcycle is hot please wait for it to cool down.
- Any factory hardware that is removed must be torqued to OEM factory recommendations - These can be found in the vehicle's user or repair manuals.



<https://ride.vision/>



ask@ride.vision

1. Unboxing and Material Overview

Box content:

1. Main Unit (ECU)
2. Wide angle HD cameras
3. Alert Indicators
4. Alert Indicators Anchors
5. GPS antenna
6. Speed sensor
7. Speed sensor installation accessories
8. Calibration ruler
9. Sticky/Screw Ball mount
10. Alcohol Pads

Required Tools:

1. Torx T10 (camera)
2. Philips PH 1*80(old) or flat head(new) screwdriver (main connectors)
3. 17mm open-ended wrench (speed sensor)
4. 8mm open-ended wrench (GPS)
5. Feeler gauge or RIDEVISION speed sensor tool.
6. Tape measure
7. Any other tools needed to remove relevant (body) parts from the motorcycle.

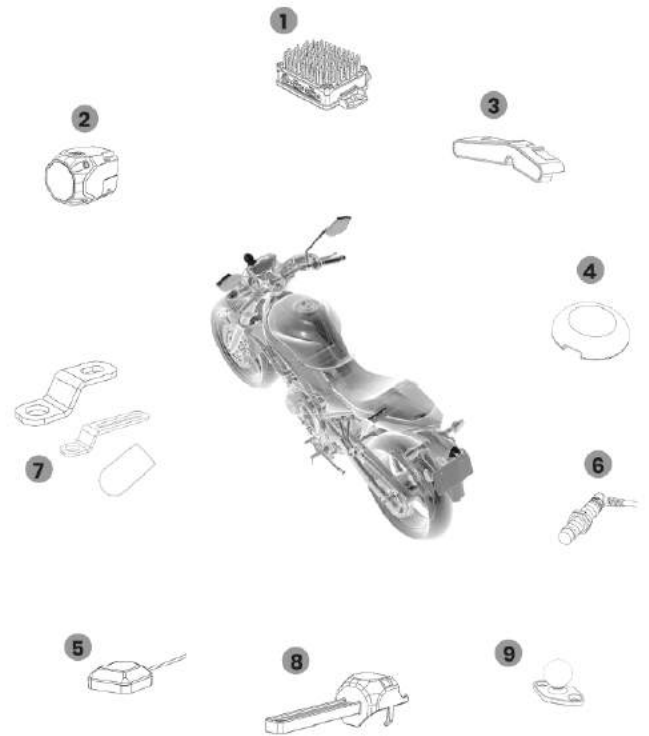

Additional Items:

For proper installation, please use black zip ties and anchors where needed.



Optional Items:

For some installations, different ball mount may need be acquired:

[RAM-B-349U](#)



[RAM-B-231ZU](#)



[RAM-B-408-75-1U](#)



[RAM-B-367U](#)



[RAM-B-273-M6U](#)



[RAM-B-272U](#)



In any case **Do not use extenders!:**

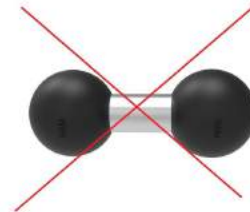

2. Preparing for installation

Adhesive guide

1. **Before mounting any component with the supplied adhesive** make sure that the working surface is flat, **clean**, and dry. If the surface is very dirty, use soap and water to clean it first.
2. If surface is unpainted (such as mirrors) scuff the surface with scotch bright (such as 3M 7447)
3. Clean the surface with the supplied alcohol pad in one direction only.
4. Once surface is dry, peel the application layer (red) and place the part to the surface
5. Keep pressure on the part (and adhesive) for **30-60 seconds**.
6. Please note, the Ride Vision system's adhesives can take up to 24 hours to fully cure after initial installation.

Critical component location guide

General:

- Identify the proper location for **all the critical components before starting to install - do not start without this stage.**
- All system components except speed sensor must be mounted above the vehicle's shock absorber.
- Route the cables away from the exhaust for easier installation and access.

Cameras:

Camera can be mounted using the supplied ball mount - using the adhesive or screws (M5).

Camera can be mounted using the optional ball accessories (1")

Camera can be mounted up or upside down.

Locate a position for the camera with the following attributes:

- Camera will be in the middle of the motorcycle as possible - max offset = 5cm
- Camera height is between **60-140 cm above the ground** - when the rider is sitting on the motorcycle - **prefer higher position when possible**
- Camera view is not obstructed
- Position not abstracting camera alignment.
- **Surface is rigid and does not move or flex by hand pressure.**
- **Do NOT mount the camera on any hanging, loose, bending, or vibrating part.**
- When using adhesive - position is flat enough to accommodate the ball mount.
- When using screws - position can hold the ball mount rigidly with screws and nuts.
- When using optional ball accessories - ball accessory is mounted rigidly

Alert indicators:

Alert indicators can be installed to any mirror **except**:

1. Completely round mirrors (Example: some Vespa mirrors)
2. Bar end mirrors (Example: Ducati Scrambler Cafe Racer)

3. Mirrors without edge (Example: Motogadget mo.view classic)
4. Mirrors with rim thicker than 6mm

Alert indicators have semi flex contraction, use the flex area to find the optimal position so the alerts indicators will sit securely on the mirror towards the outer edge leaving at least 5-10mm.

Speed sensor:

On the front wheel, locate a bolt - **not related to the braking system** to hang the speed sensor bracket on. Fender bolts are ideal locations.

The position should enable the speed sensor to be in front of (i.e. sense) a rotating bolt or the rim of the wheel.



Fender bolt used to position the speed sensor next to wheel rim



Fender bolt used to position the speed sensor next to disc bolt

Main unit:

- **Do not use fully sealed areas such as the rear case or scooter underseat.**
- The main unit can be positioned in any orientation, internal or external (see restrictions below) as long as the main unit is firmly secured to the motorcycle/ scooter body/ frame.
- Main unit position should not obstruct any motorcycle moving parts in any condition.

For motorcycles:

The main unit can be placed under the seat or under a fairing part if the area is vented (air circulation).

Note: some motorcycles have *sealed under seat storage* that make this area unsuitable for main unit installation.

For scooters:

The main unit can be placed between the underseat storage and fairing/frame if the area is vented (air circulation). This area is usually preferred

Other option:

If no suitable location is found - contact the ridevision support team.



KTM duke 390 - under-seat area is vented.



BMW C400GT - unit is placed between the frame and the under-seat storage

3. Front Camera Installation

Front Camera



Blue Connector

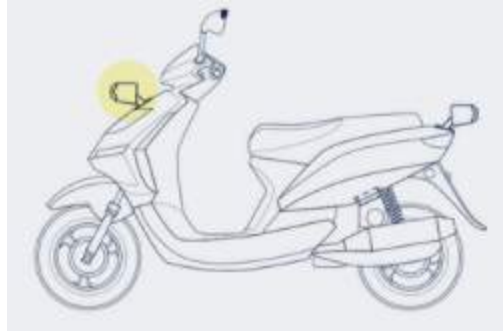

1. Install the ball mount according to the **Critical component location guide** and **Adhesive guide** (if using adhesive). No need to lock the camera to the ball.
2. Run the 3 white connectors to the handlebars area and the blue connector to ECU location.
3. Make sure all motorcycle moving parts are not obstructed by cables.



Naked bike installation



Adventure bike installation

4. Rear Camera Installation

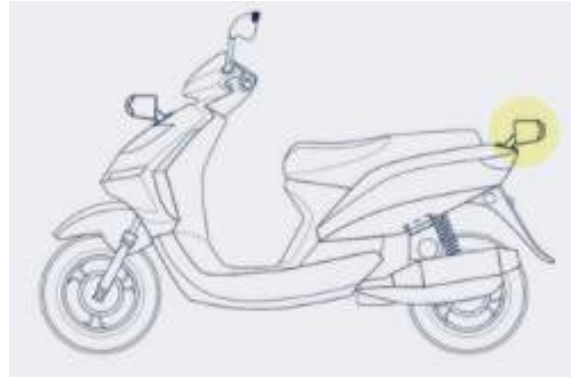

1. Install the ball mount according to the **Critical component location guide and Adhesive guide** (if using adhesive). No need to lock the camera to the ball
2. Run the black connector to the Main Unit (ECU) location, and run the power wires to the battery area.
3. Connect the wires to the battery and ignition:
 - a. **Red** = Positive (+12v) battery terminal
 - b. **Black** = Negative (-12v) battery terminal
 - c. **Yellow** = Ignition wire (+12v switched)

Connect the ignition wire to the accessory port or ignition switch - use a multimeter to make sure this line is only active when the ignition is on, or reference the vehicle's owner manual.



Ball mount-screw adapter (not provided).



Below rear rack (adhesive)

5. GPS Installation

GPS Antenna



1. Antenna should be positioned outside with a clear sky view facing up **for optimal performance.**
2. Optional: Antenna can be positioned under a plastic part:
 - a. Antenna should have a clear sky view below plastic.
 - b. Antenna is facing up
 - c. *Note: GPS performance may be compromised*
3. **Make sure the antenna is not obstructed by any metal parts.**
4. Install the gps antenna according to the **Adhesive guide.**
5. Run the wire to the Main Unit (ECU) location.



GPS mounted on the exterior of the vehicle.



GPS mounted under a plastic with additional adhesive (not included)



6. Speed Sensor Installation



CAUTION! Use only fender (or non brake related) bolts to hang the speed sensor bracket.

1. Option 1 - Installing the sensor in front of disk brake / abs plate bolt:

- a. Using the supplied metal brackets to place the speed sensor in front of the desired bolt.
- b. If the desired bolt head is Torx or Allen position the speed sensor off-center (to the bolt head).



2. Option 2 - Installing the sensor with wheel-rim trigger:

- a. Bend the trigger on the rim without mounting it, so that it conforms to the exact shape of the rim - round edge should be facing the tyre
- b. Install the trigger according to the adhesive guide.
- c. Using the supplied metal brackets, place the speed sensor in front of the trigger.



3. Use a feeler gauge to position the speed sensor between 2mm to 3mm from the bolt/trigger

4. Use a 17mm wrench to lock speed sensor nuts on both sides of the bracket.
5. Route the sensor's cable towards the 3 white connectors coming from the front camera's cable. Use Zip-Tie to secure the cable with the existing wire looms. Be sure to leave enough wire slack to accommodate for the motorcycle fork travel.
6. Connect the speed sensor connector to the connector with red shrink.

7. Alert Indicators Installation



1. Alert Indicators are semi-flexible, allowing them to be mounted on any mirror shape **except for completely round mirrors**.
2. **Dry mount** the alert indicator on the relevant mirror (blue-left, white-right):
 - a. Use **angular motion** to ensure all 3 clips are grabbing the mirror rim and the red area(sticker - don't peel it yet) is not touching the mirror until the end of the movement.
 - b. Leave at least a "finger"(5-10mm) between the indicator and the mirror edge.
 - c. Dry mount a few more times if necessary to get to **angular motion** movement easily.
7. Install the alert indicators in an **angular motion** - handle the adhesive according to the **Adhesive guide**.
8. Dry fit the anchor to route the cable towards the mirror arm, make sure the cable is flat in the groove.
 - a. New anchor: bend the anchor to fit the mirror shape.
9. Install the anchor according to the **Adhesive guide**.
10. Route the indicator's cable along the mirror's arm to the 3 white connectors coming from the front camera's cable. Use zip ties to secure the cables.
 - a. Be sure to leave enough cable slack to account for mirror movement and to avoid pinched wires.
11. Connect the connectors according to the shrink color.



Correctly installed Alert Indicator



Alert Indicator anchor(old)



Alert Indicator anchor(new)

8. Main Unit (ECU) Installation



1. Connect all cables to the Main Unit:
 - a. Tighten main connector screws all the way in, **up to the point where the screw stops turning.**
 - b. GPS antenna: begin with finger tight tension, then tighten the nut with an 8mm spanner $\frac{1}{4}$ turn.
2. If the unit is installed externally - use 4 screws and nuts (M5) to secure the main unit to the motorcycle - according to the **Critical component location guide.**
3. Otherwise Install the Main Unit according to the **Critical component location guide and Adhesive guide.**



Additionally the Main Unit must be secured to the motorcycle to avoid any damage to the Main Unit or the motorcycle in case Main Unit accidentally disconnects:

- The Main Unit must be secured to the motorcycle with at least 2 screws.
- Alternatively, its possible to secure the unit with zip ties to the motorcycle **ONLY IF:**
Chosen zip ties can hold the weight of the maint unit and the no motorcycle parts will be damaged in any condition if the Main Unit accidentally disconnects.



9. Verification

Verify system power

- Turn the ignition on
- Wait ~15 seconds
- All LEDs in the Alert indicators should glow ~5 times.
 - This means that the power is OK but the system is not calibrated and/or activated.
- If LEDs do not turn on, please go back and check the installation according to stages 2, 4 and 8.

Verify speed sensor

- Turn on the ignition
- Rotate the front wheel by hand (with center stand) or by moving the motorcycle.
- The red LED on the speed sensor should turn on and off as long as the wheel rotates
 - Note: This LED is not visible in direct sunlight.
- If the speed sensor LED is constant on or constant off, please go back and check the installation according to stages 2 and 6.

10. App

Registration + Activation

1. Download and install Ride Vision PRO or Ride Vision LITE app for your Android or iOS device from Google Play / Appstore. (for calibration only Android is supported)
2. Open the app and register as a new user. [screenshot 1-2]

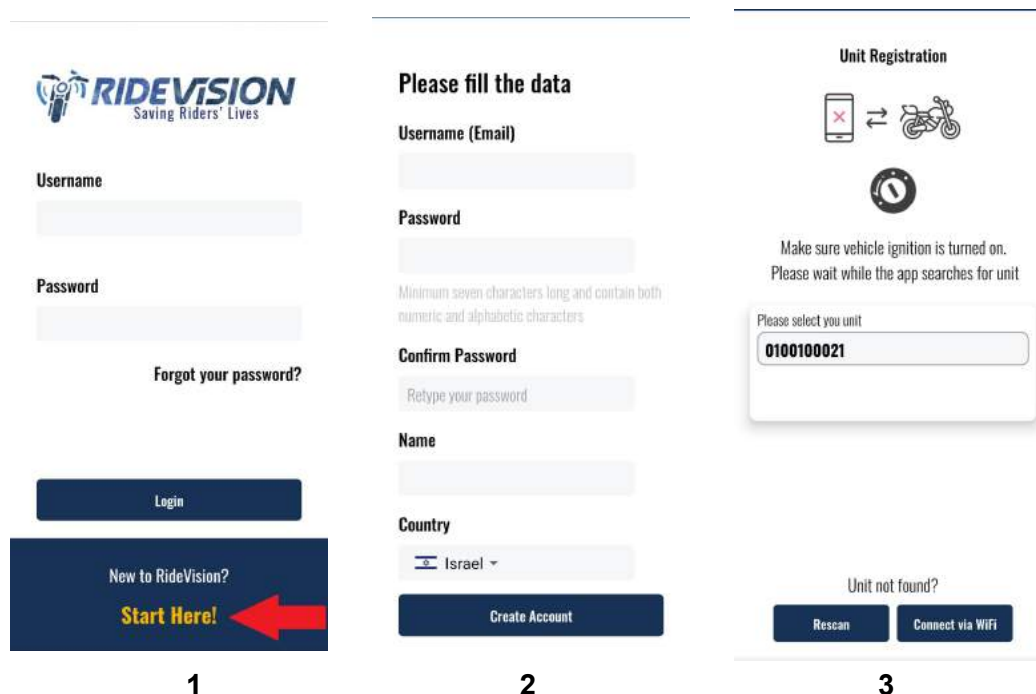

3. Turn on the motorcycle ignition and allow the system to power on (10 seconds).
4. **Option 1** - At this stage the app will automatically search for you new system
 - a. If the serial number pops up on the screen, click it. *[screenshot 3]* **Make sure Bluetooth and location services (GPS) are turned on for this step.**
 - b. (Optional) If not, you can Rescan or connect via Wi-Fi (option 2 - see section 5)
 - c. If completed successfully, please continue to item 6.
5. **Option 2** - Connect via Wi-Fi
 - a. Follow the app instructions and press “connect”. *[screenshot 4]*
 - b. You should be promoted into your phone setting or Wi-Fi setting. If needed, navigate to your phone Wi-Fi settings.
 - c. connect to the network that starts with **iRide**
 - d. Your default password is 12345678
 - i. **Make sure Auto reconnect for this network is OFF**
 - ii. If prompted by phone - keep the connection alive
 - iii. Make sure “location” service is on (GPS).
 - e. Return to the app - if all is good - you should see “connected” in green and unit serial number displayed on the screen *[screenshot 5]*
 - f. Press “Complete registration” - and then **disconnect** from iRide-XXXX network and **connect back to regular network** (mobile data or your home Wi-Fi network)
 - g. Return back to the app.
 - h. Press on the Wi-Fi network sign on the top right and connect back to the iRide-XXXX network
 - i. Return to app
 - j. You should see the Wi-Fi icon in green
 - k. Swipe screen down to sync data (no ride data is available at this point). *[screenshot 6]*

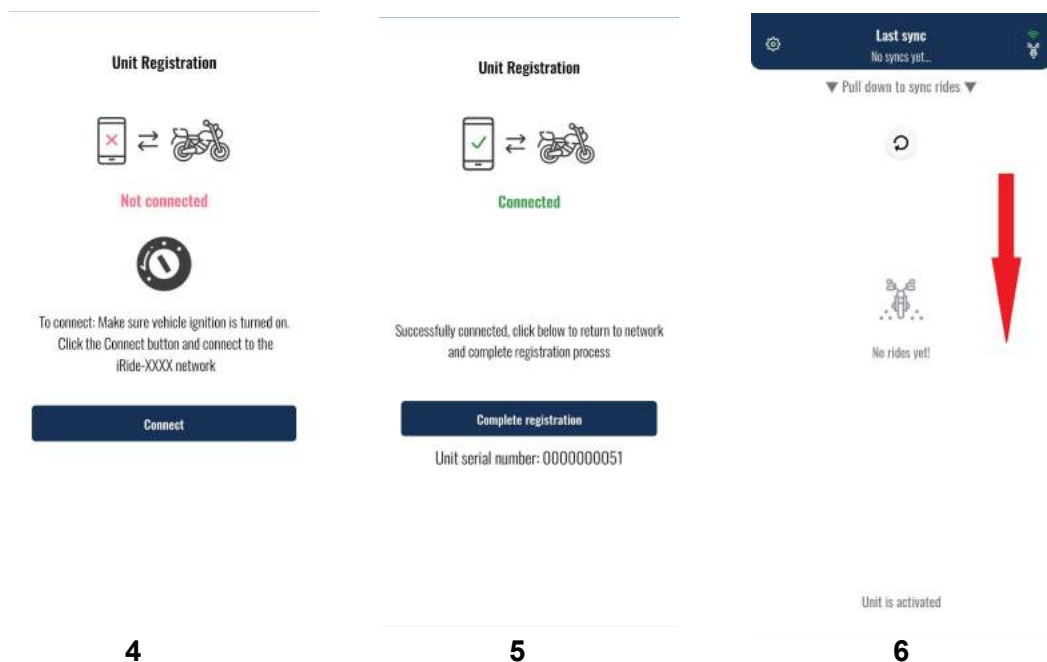

6. you should now be in the main app - wait a few seconds - you should see the “unit is activated” at the bottom of the screen. [screenshot 7]



7

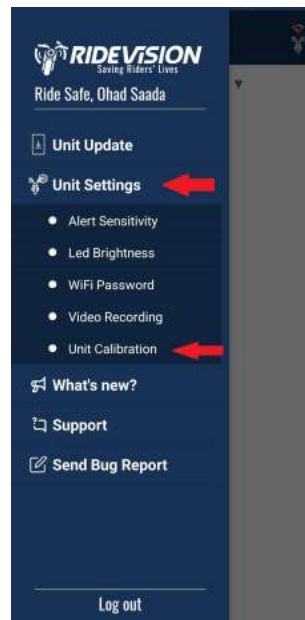

8

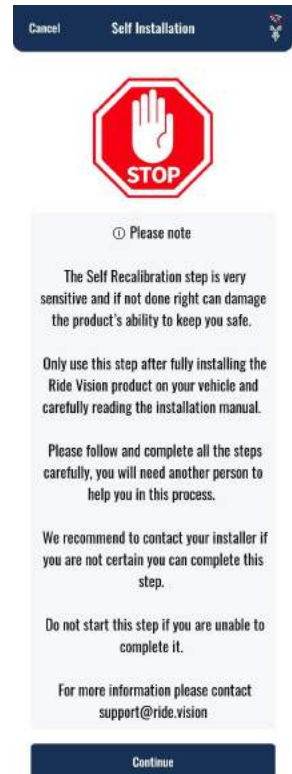

9

Calibration

Note: For this stage **two people are needed** - usually rider/owner and installer.

Note: This stage should be performed **on a flat ground**.

1. Press on the settings icon
2. Click “Unit Setting” [screenshot 8]
3. Click “Unit Calibration” [screenshot 9]
4. **Read** and press continue [screenshot 10]
5. Connect to Unit’s WIFI -**if not already connected**- iRide-*{serial number}* [screenshot 11]
 - a. Default password is: 12345678
 - b. Make sure location services are turned on (GPS)
 - c. Note: some android phones will pop-up a message saying there is “no internet access on this network” - make sure you keep the connection [screenshot 12]
6. Wheel configuration:
 - a. Insert front wheel tyre size (written on the tyre). [screenshot 13]
 - b. Mark whether the trigger was installed
 - i. If not: insert the number of bolts that are in front of the speed sensor sensing circumference. [screenshot 14]
 - c. Press Next.



11



12

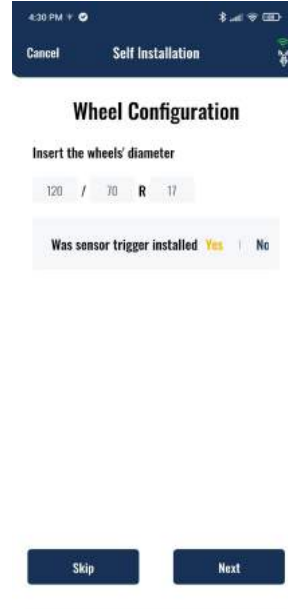

13



14

7. Main unit calibration:

- a. Place the motorcycle on the **side stand**.
- b. Make sure **the rider is not on the motorcycle, engine is off and don't touch the motorcycle or lean on it**.
- c. Press the first button: "place bike on side stand" [screenshot 15]
 - i. You should see OK next to the button
 - ii. If you see an Error - press restart and go back to the stage above.
 - iii. *If the motorcycle is not equipped with a side stand - contact support.*
- d. From this stage on, the rider/owner of the motorcycle goes on the motorcycle and levels it with his legs until the end of the calibration (!).**
 - i. **do not use center stand or wheel locking system(3 wheelers)**
- e. Once the rider is leveled, ask him to stay still and press the 2nd button: "sit and center the bike with your legs" [screenshot 16]
 - i. You should see OK next to the button
 - ii. If you see an Error - press restart and go back to the calibration stage 3.b.
- f. Press Next.

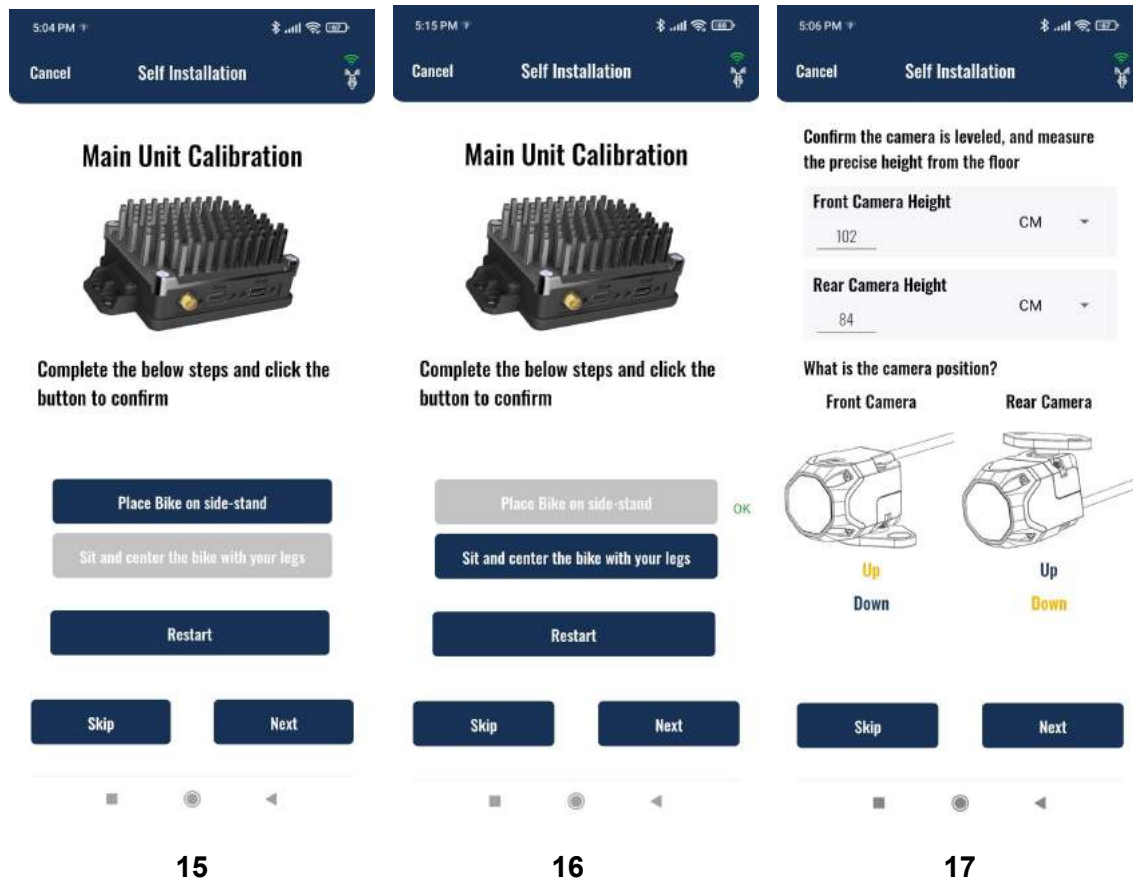

8. Camera Height & Orientation:

- a. Enter both cameras height from the ground to the center of the lens [screenshot 17]
- b. Select both cameras orientation ('R' on camera is 'up')
- c. Press Next

9. Camera calibration

- a. Attach the supplied calibration ruler to the (front) **camera** at a 45-degree angle. [screenshot 18-19]
- b. **Move the camera such that the bobble sit inside the circle and the ruler long arm is parallel to the motorcycle movement:** [screenshot 20]
 - i. Front camera:
 1. If the camera moves with handlebars, make sure the arm (camera) and front wheel are parallel
 2. If the camera doesn't move with handlebars, make sure the arm (camera) and motorcycle (imaginary) centerline are parallel.
 - ii. Rear camera:
 1. Make sure the arm (camera), rear wheel and motorcycle (imaginary) centerline are parallel.
- c. Use Torx T10 to tightly secure the camera position screws

RV 1 Installation Manual



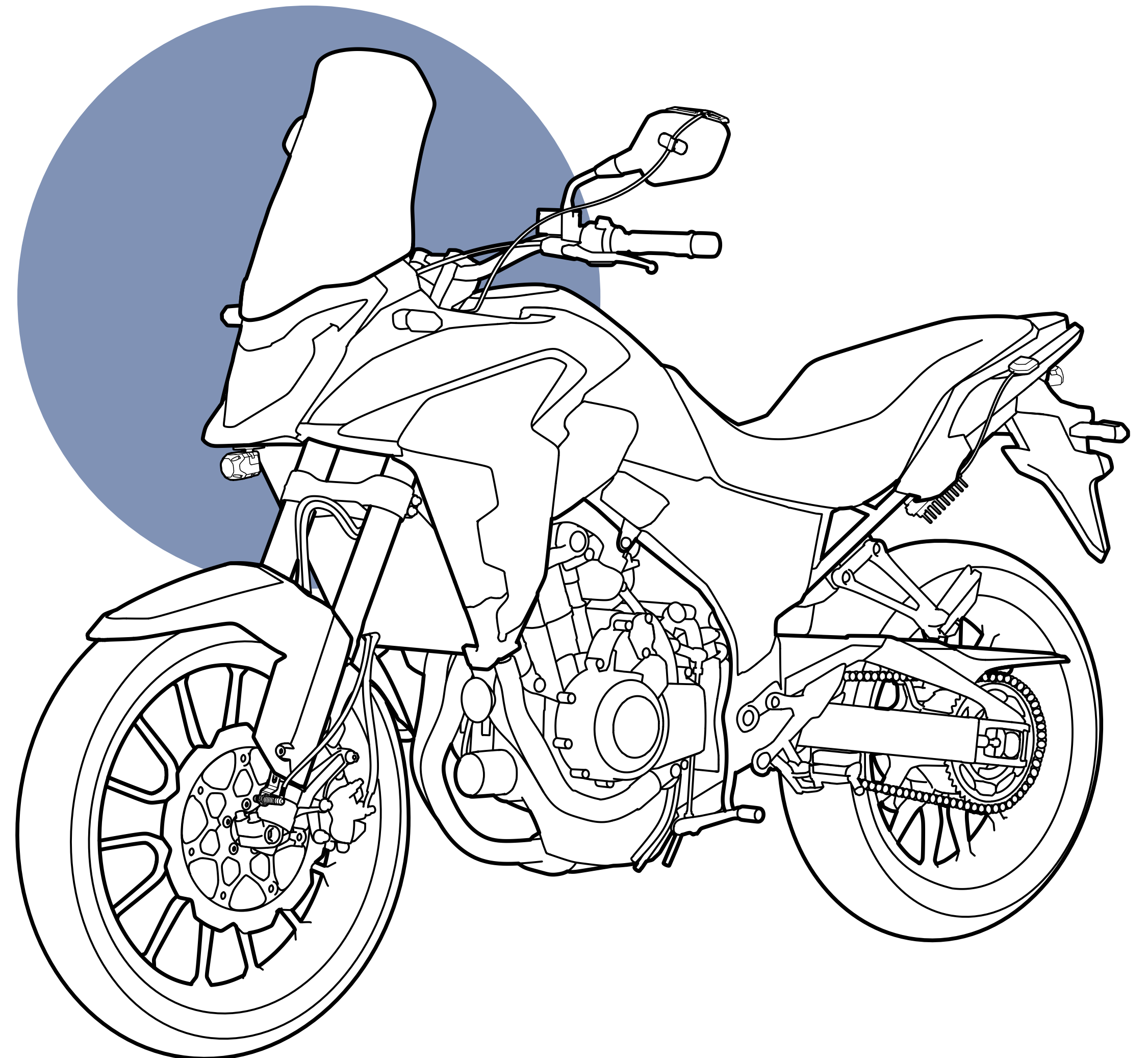
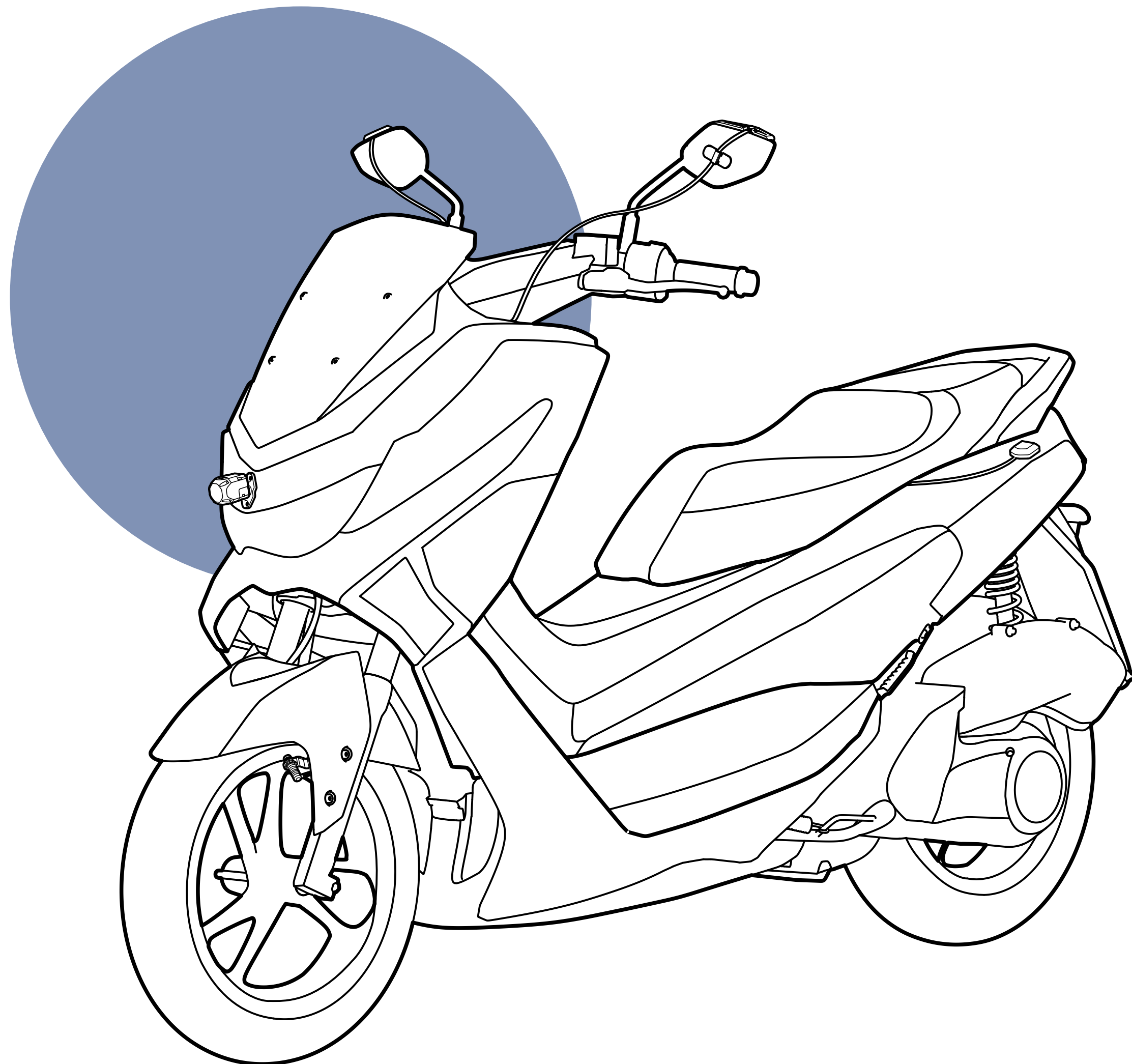

RIDEVISION

Saving Riders' Lives

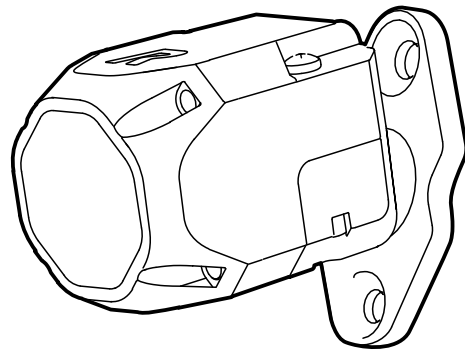
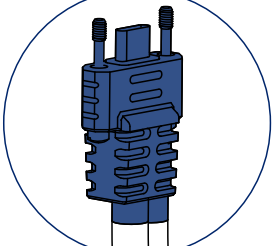
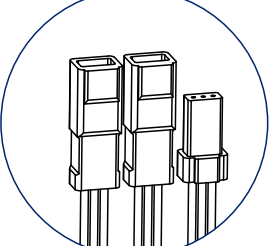
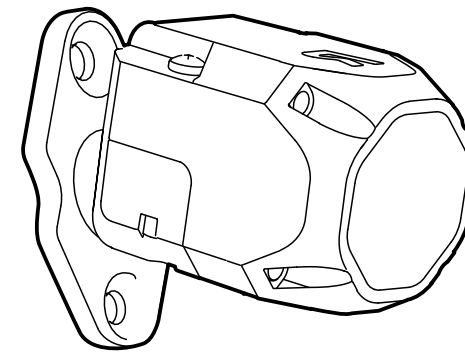
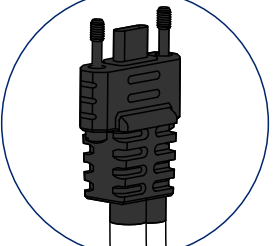
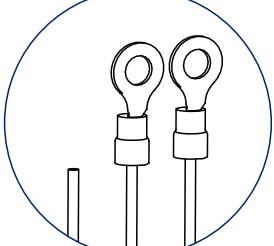
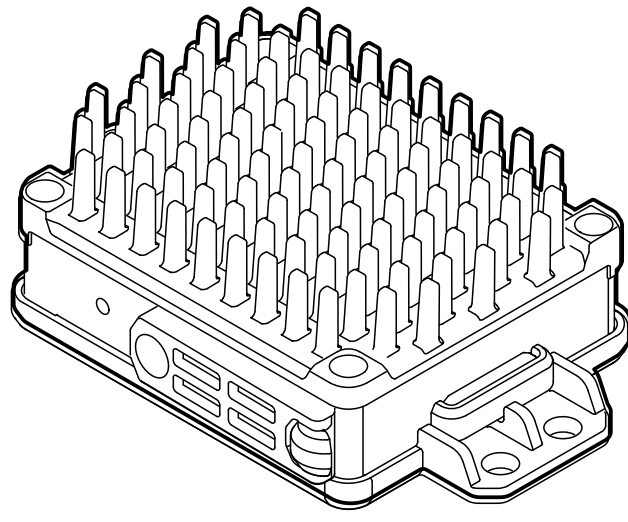
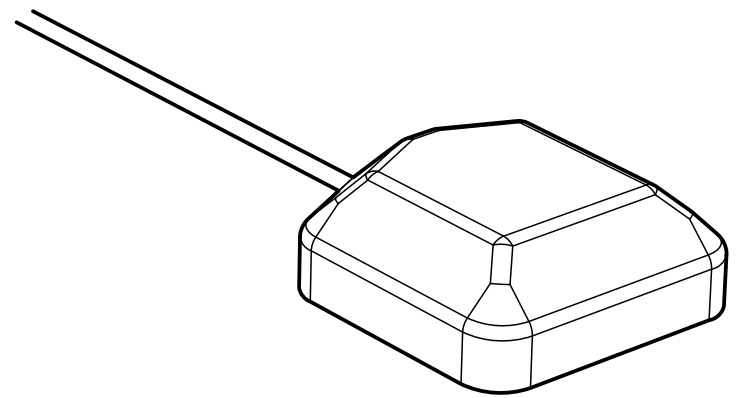
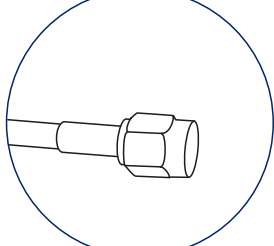
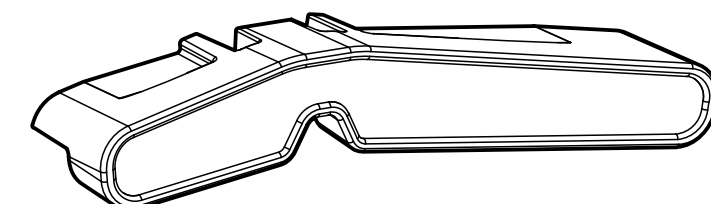
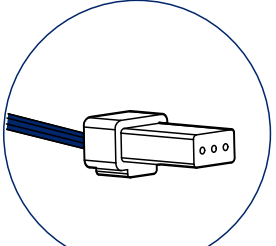
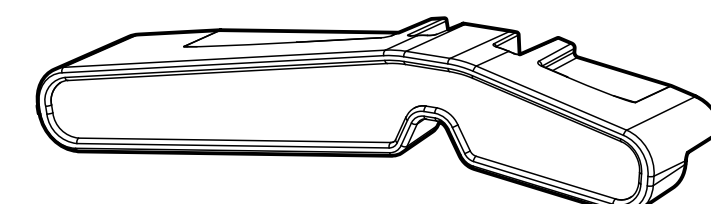
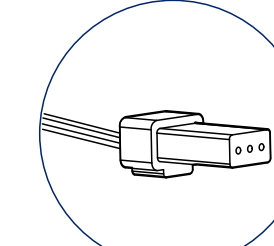
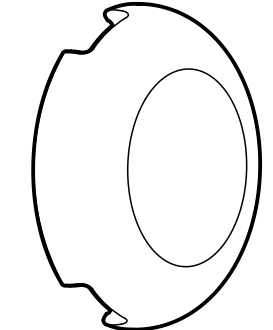
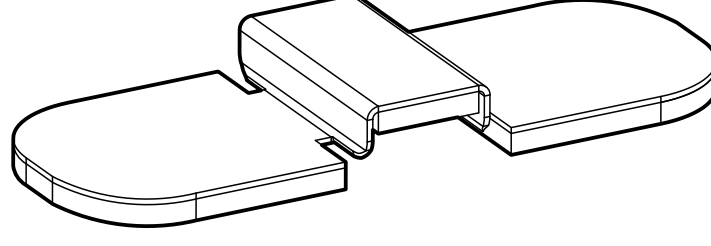
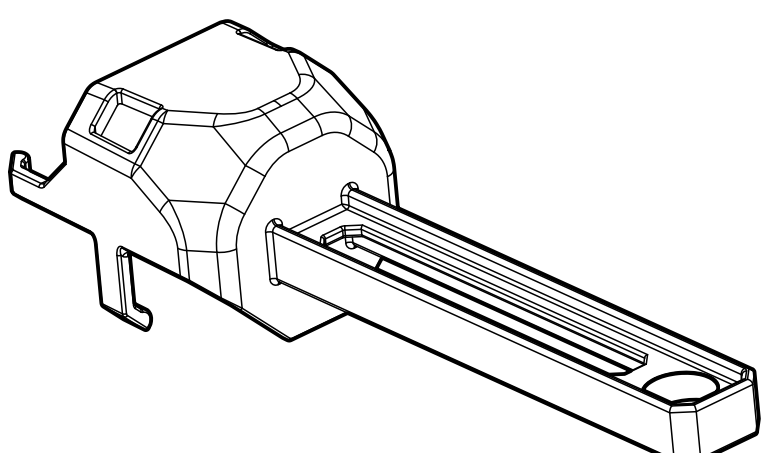
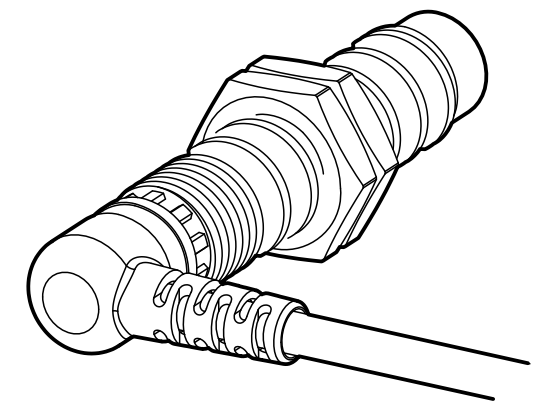
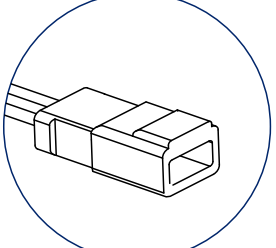
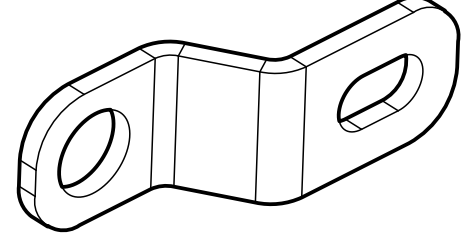
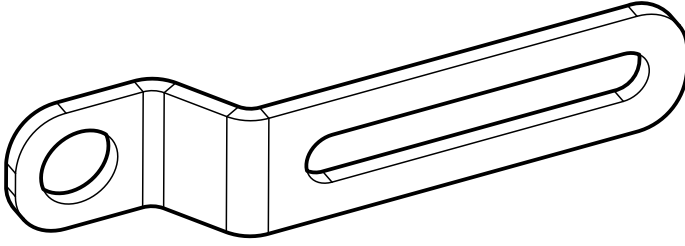
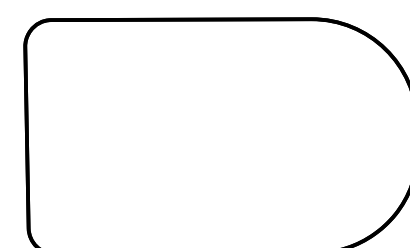

Ride Vision 1 Content

<p>Front camera</p>   	<p>Rear Camera</p>   		 
<p>Left Indicator</p>  	<p>Right Indicator</p>  	<p>X2</p>  	
 	 		<p>X5</p>  

Optional Accessories

Optional Ride Vision Accessories

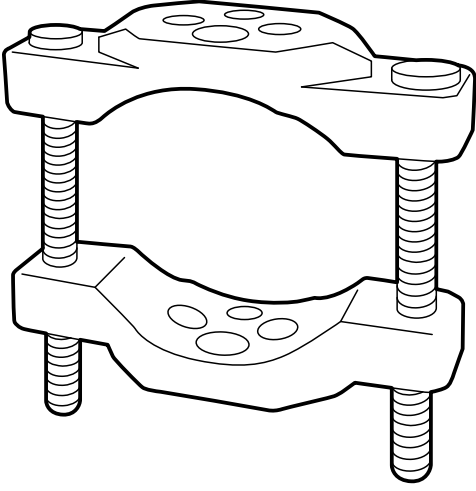
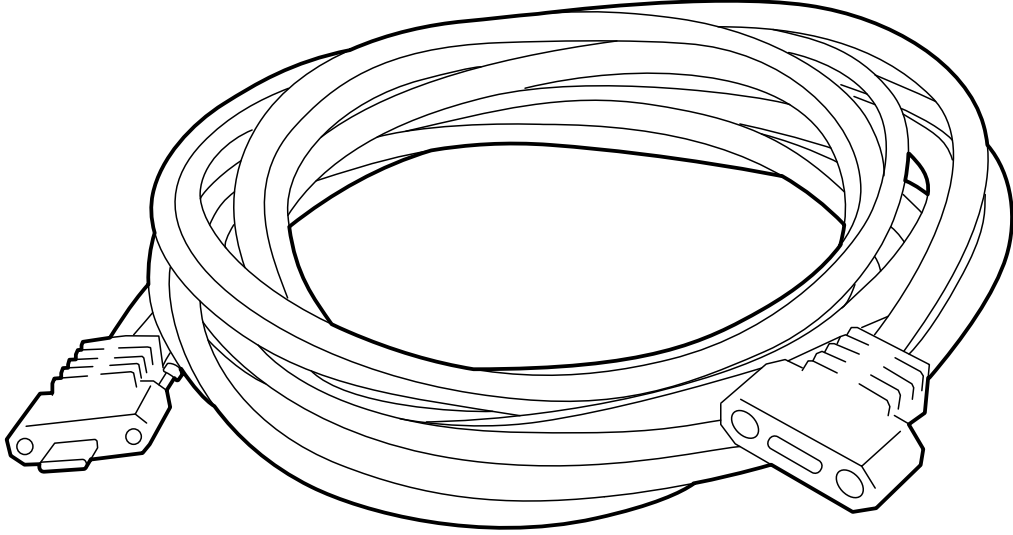
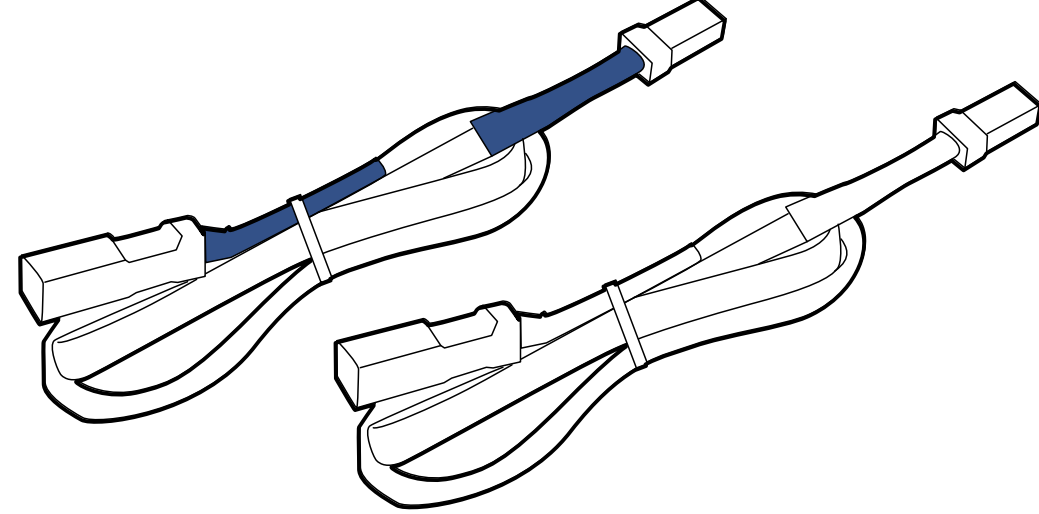
<p>speed sensor bracket</p>  <p>EXRV009/8</p>	<p>extension cable</p>  <p>CABRV0007</p>	<p>Indicator extension cable</p>  <p>EXRV0018</p>
--	---	--

Optional Add-Ons

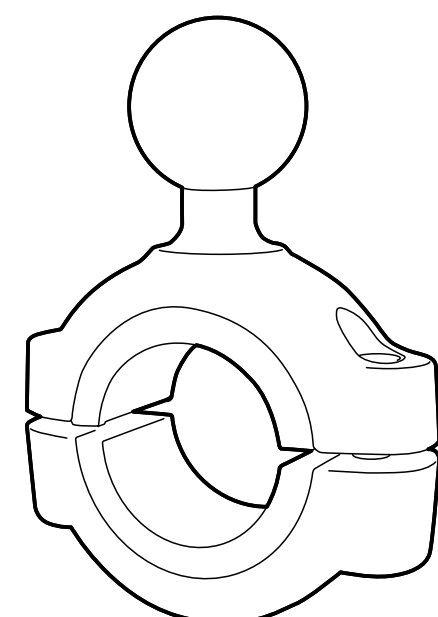
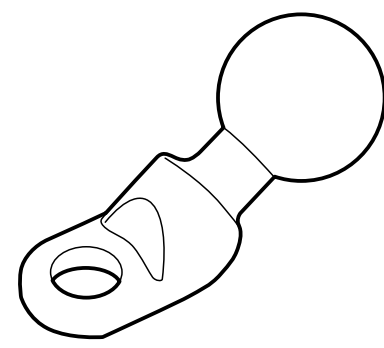
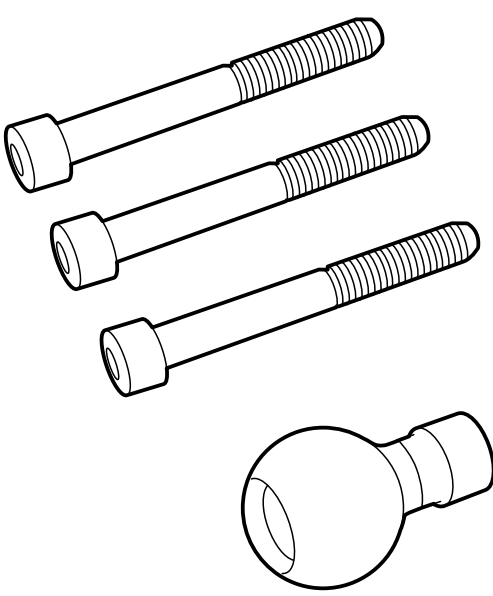
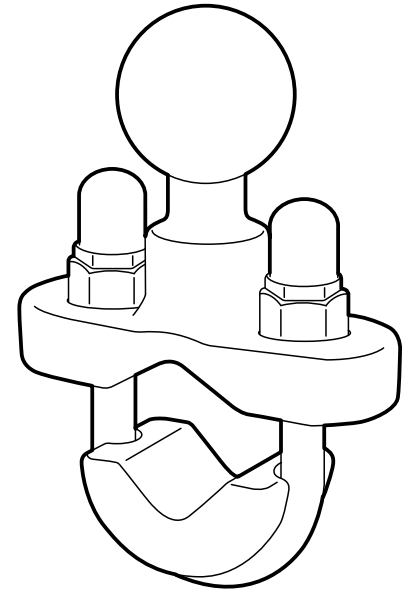
 <p>RAM-B-408-75-1U</p>	 <p>RAM-B-272U</p>	 <p>RAM-B-367U</p>	 <p>RAM-B-231ZU</p>
--	---	---	--

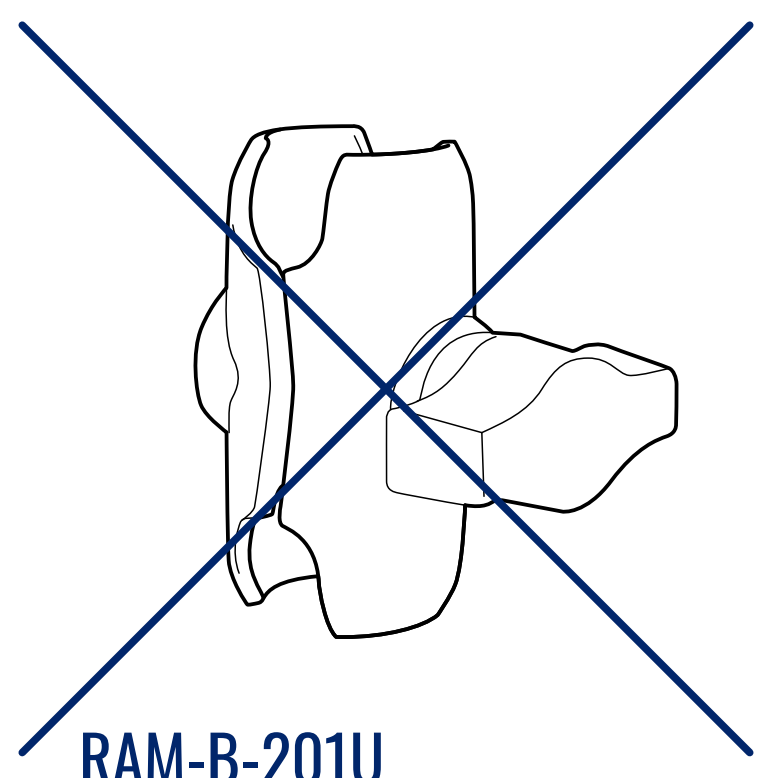
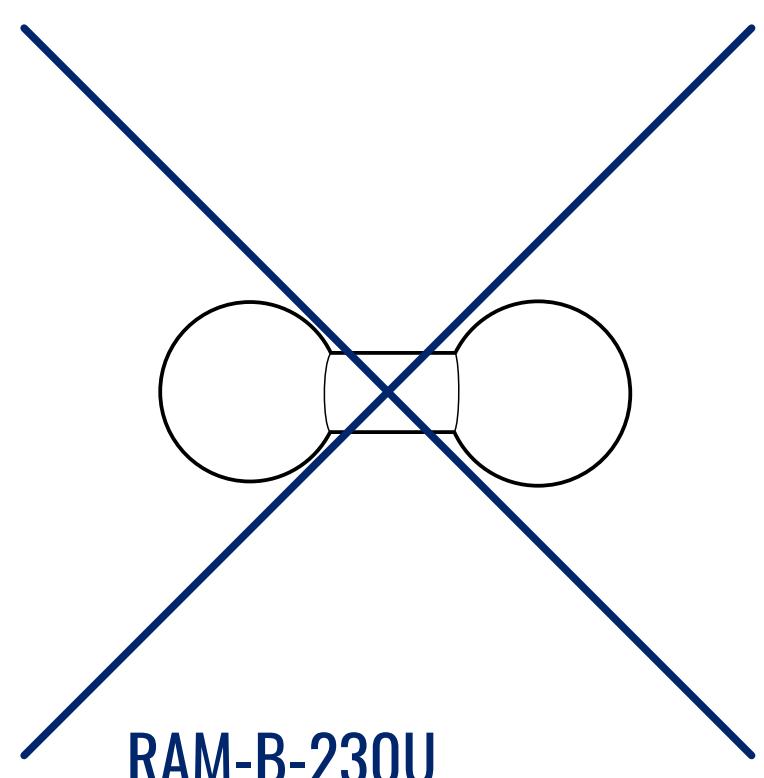
 <p>RAM-B-201U</p>	 <p>RAM-B-230U</p>
---	--

Tools

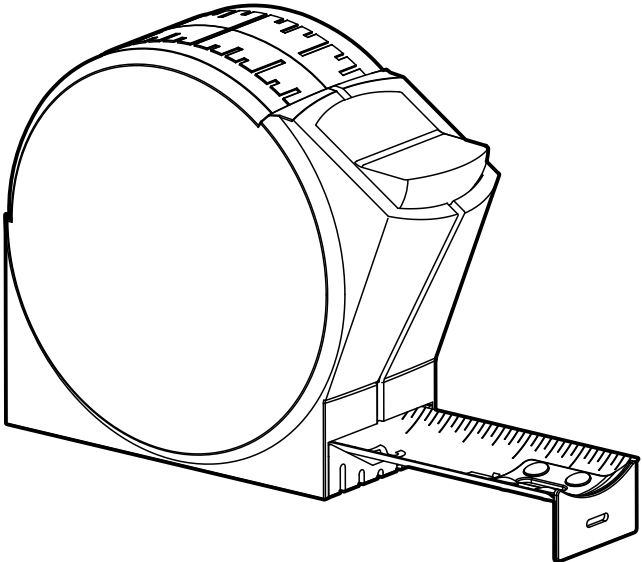
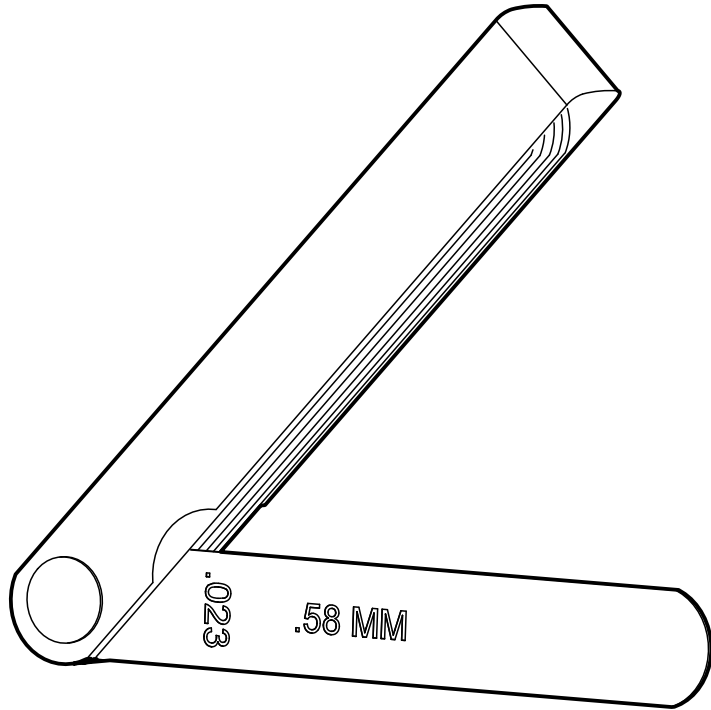
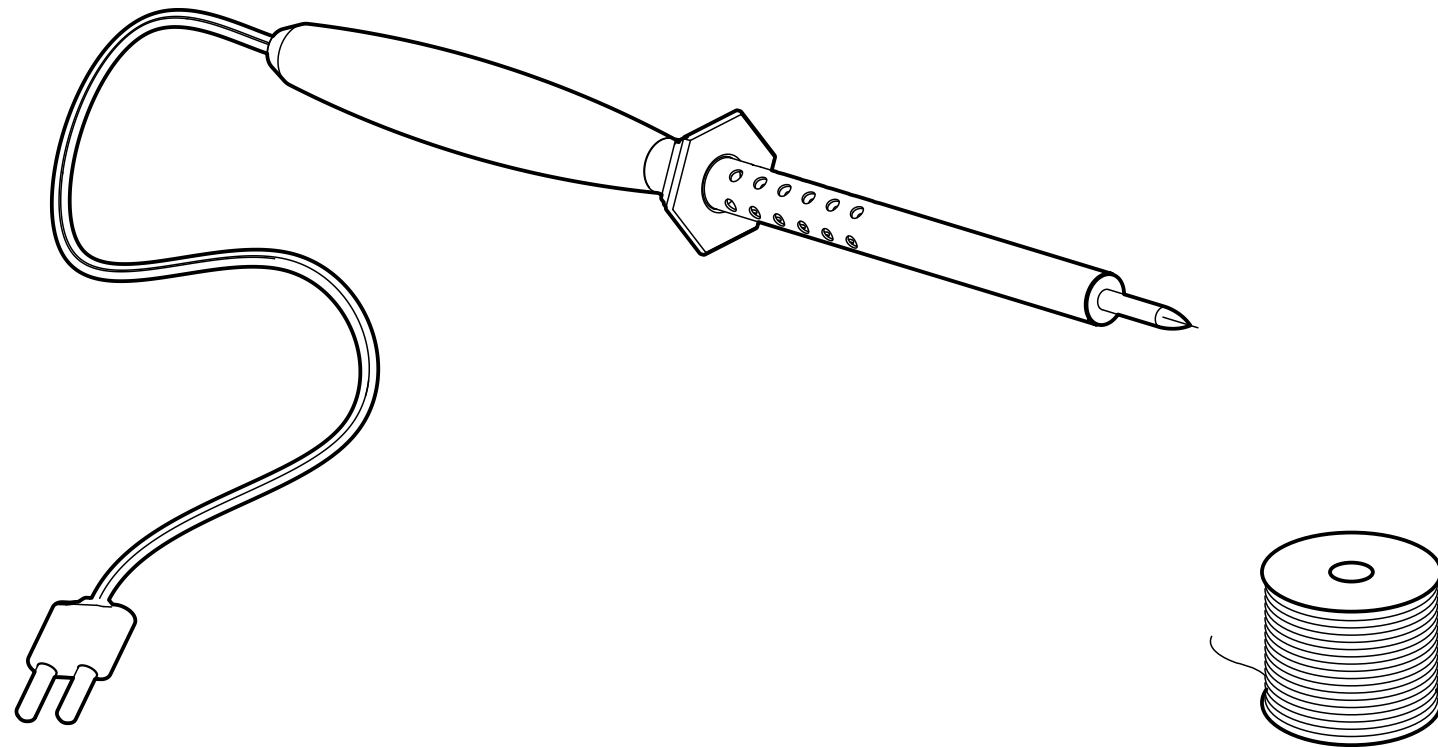
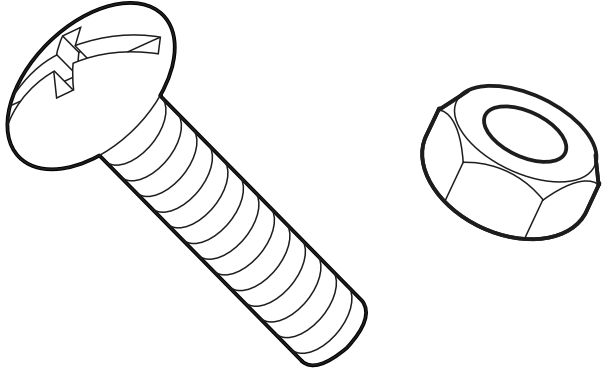
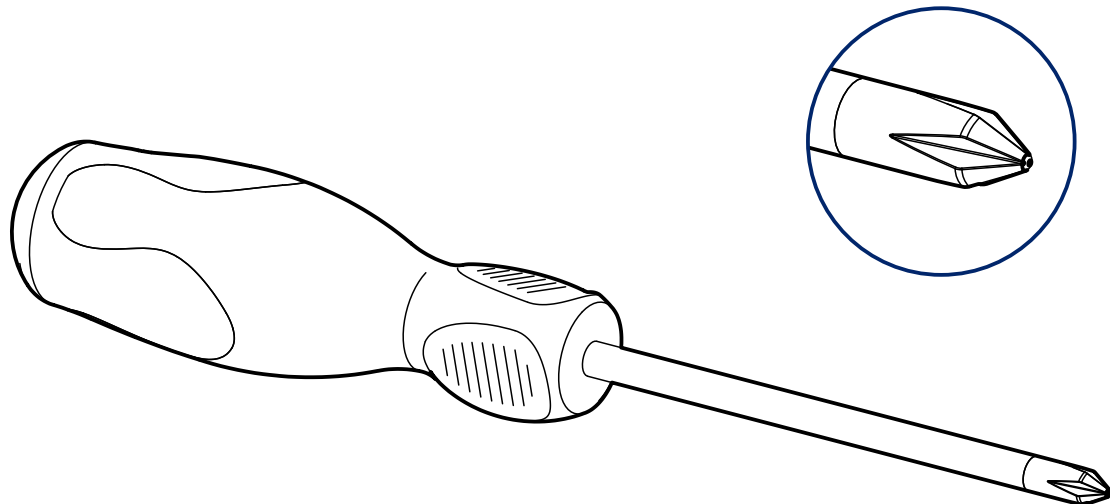
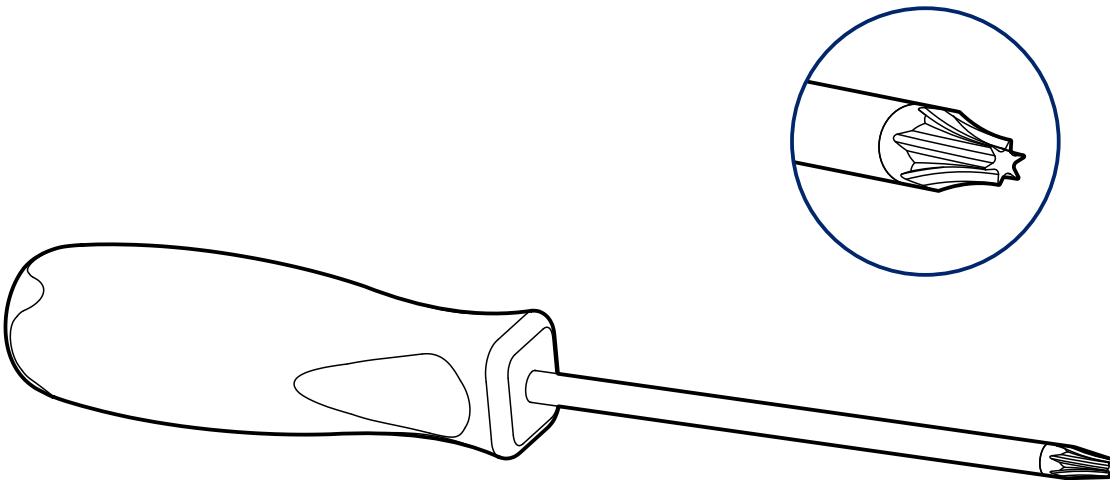
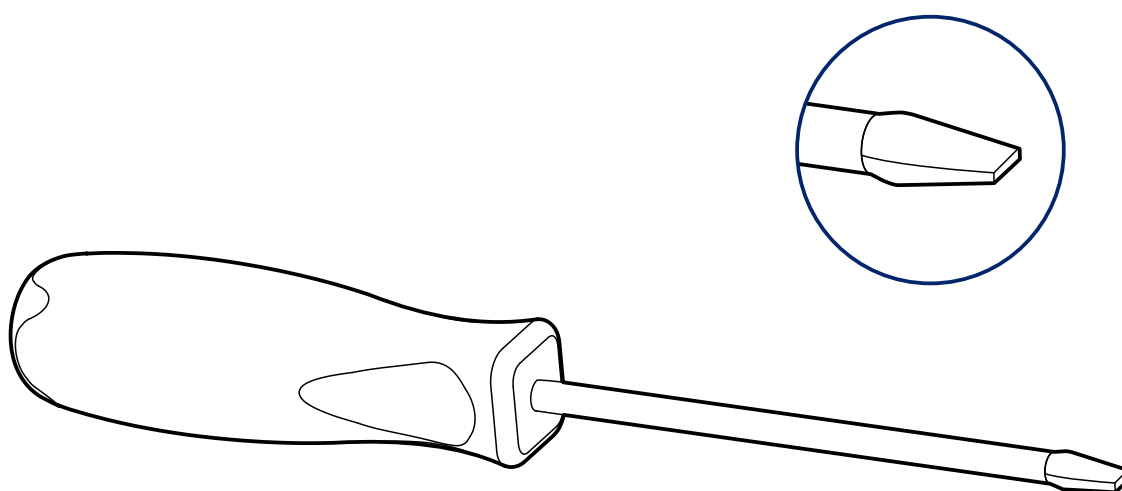
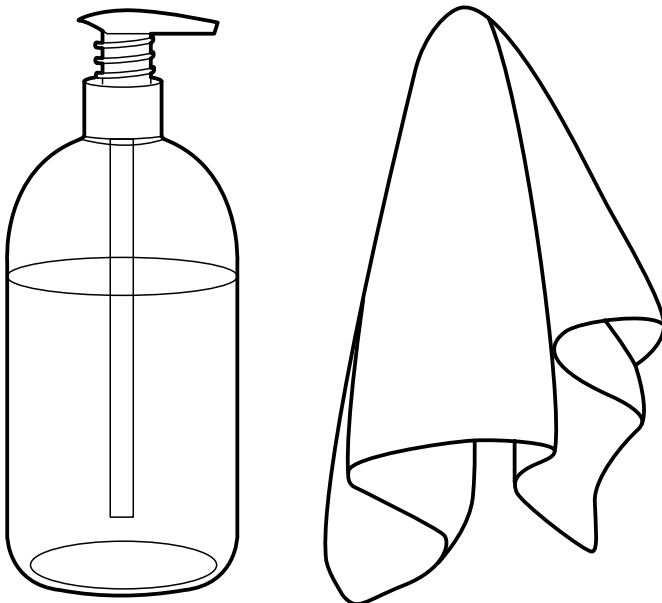
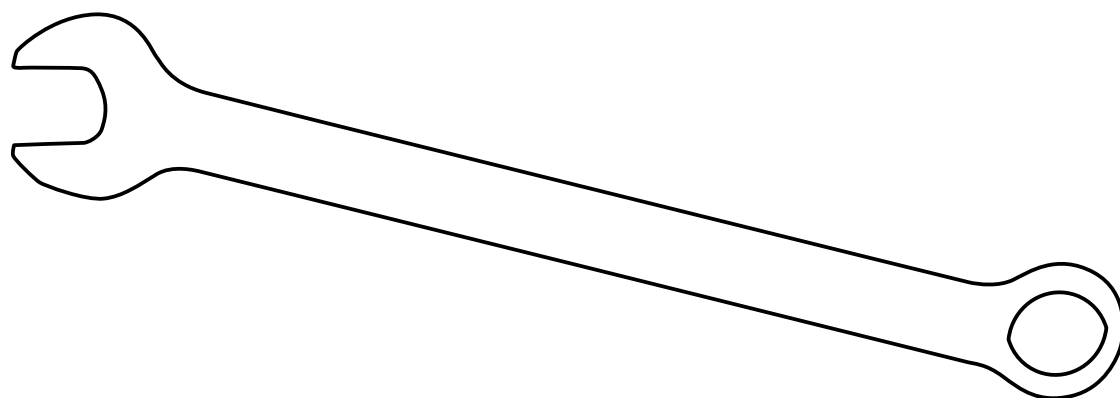
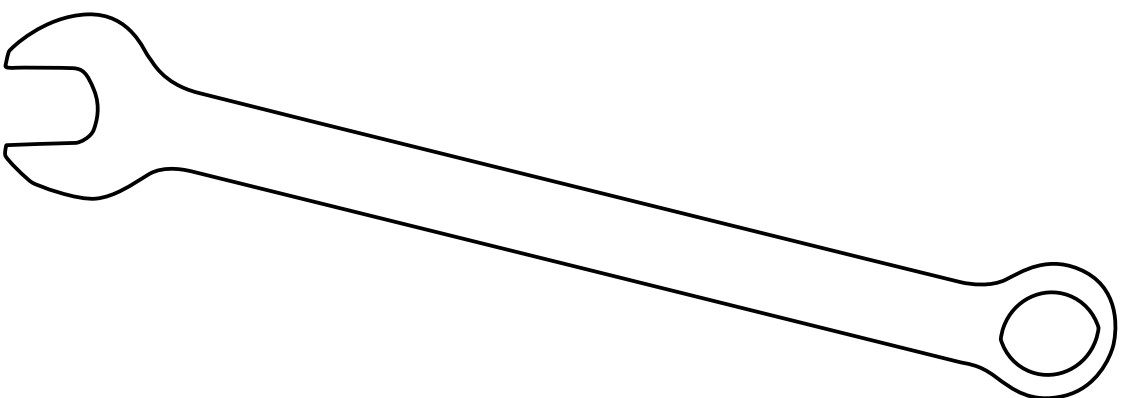
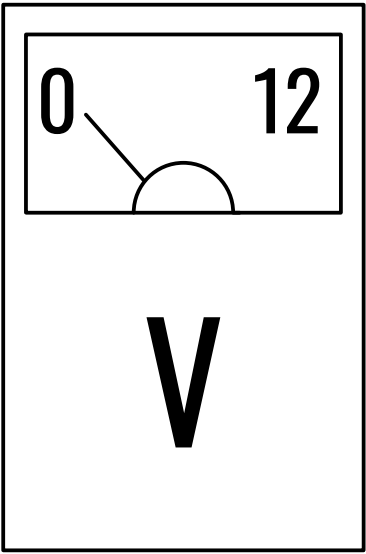
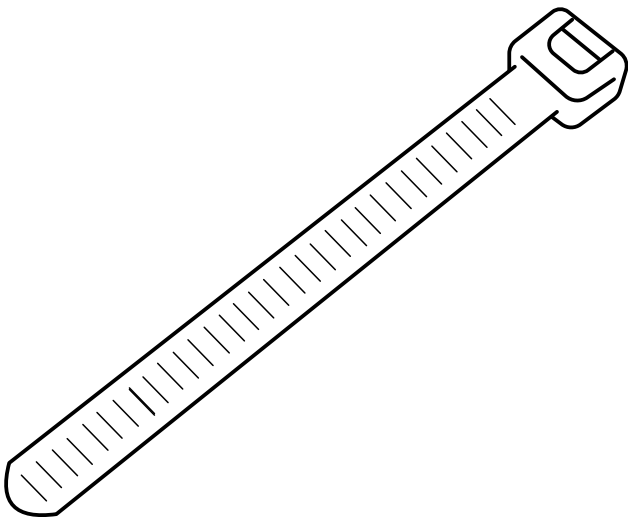
			 M5
 PH 1*80	 TORX T10	 3 mm	
 8mm	 17mm	 Multimeter	

 **Adhesive Usage Guide**

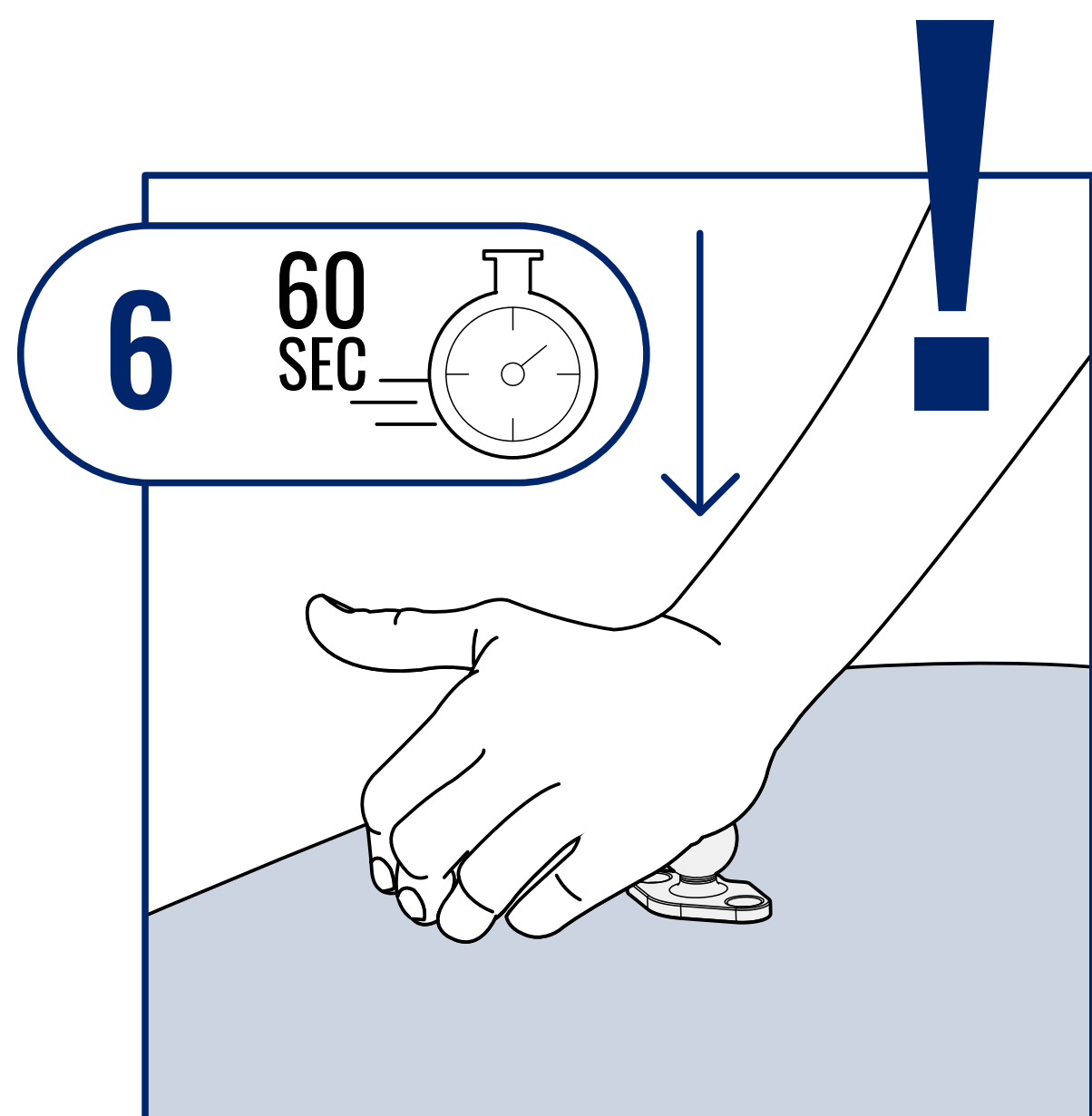
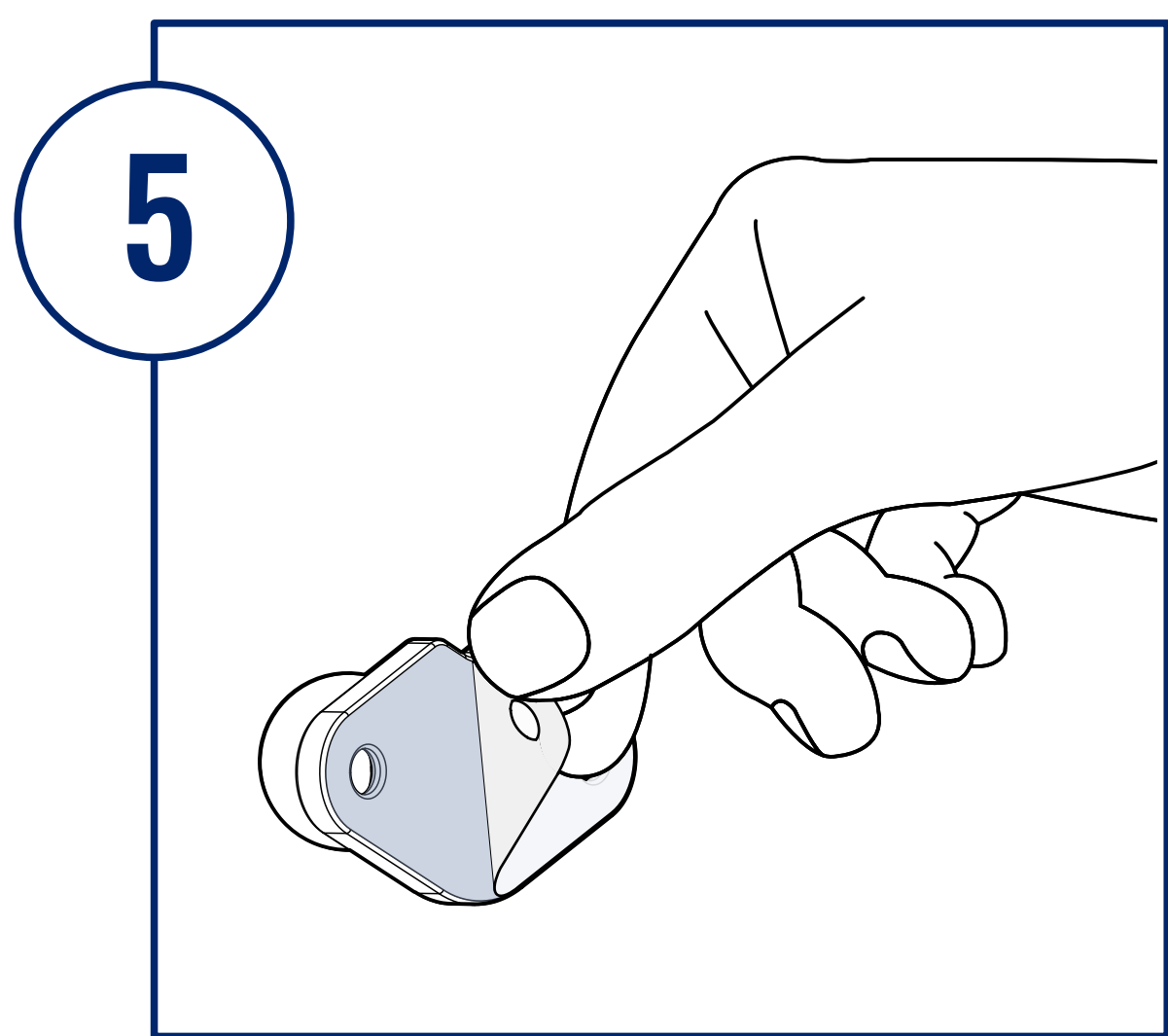
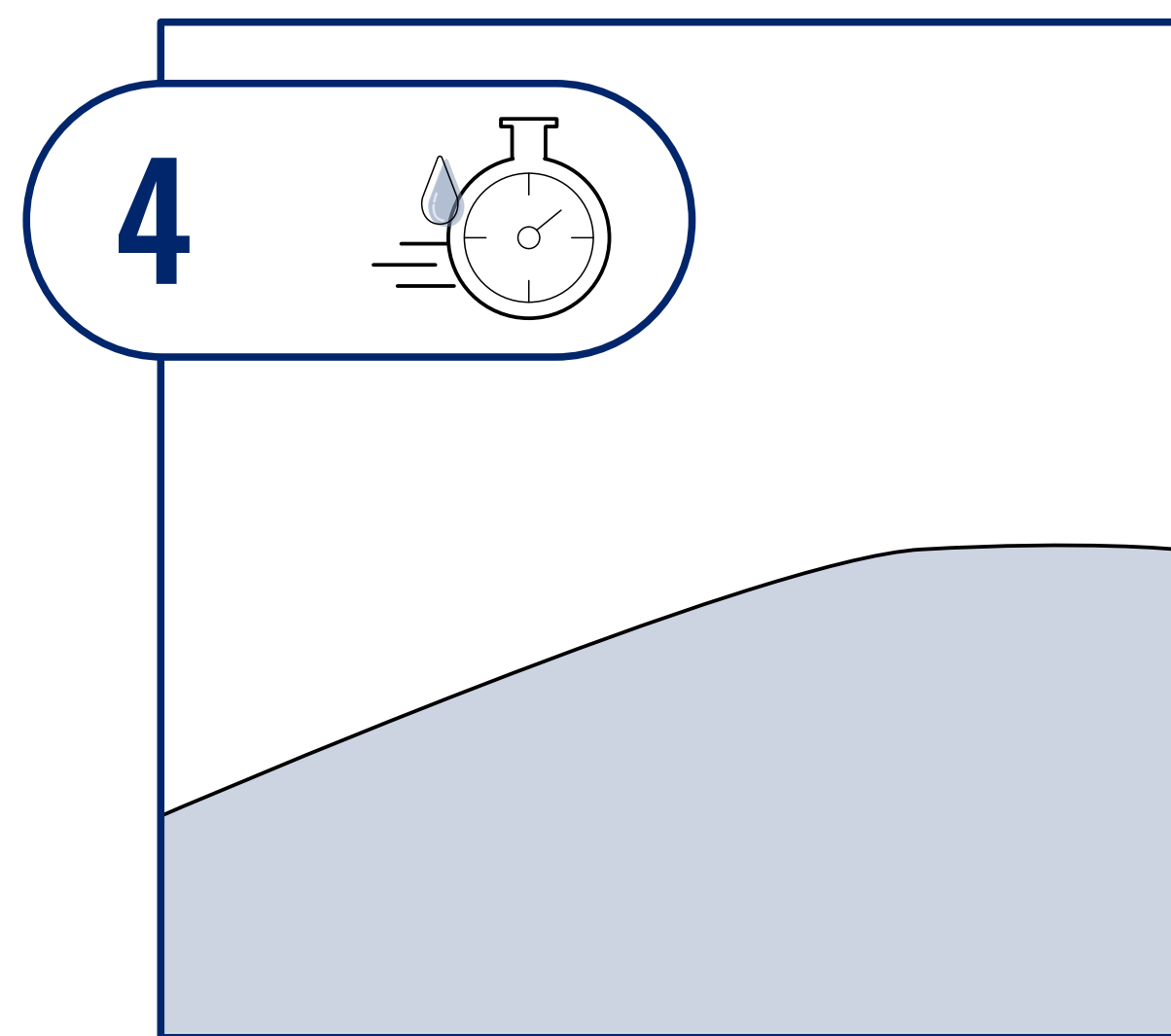
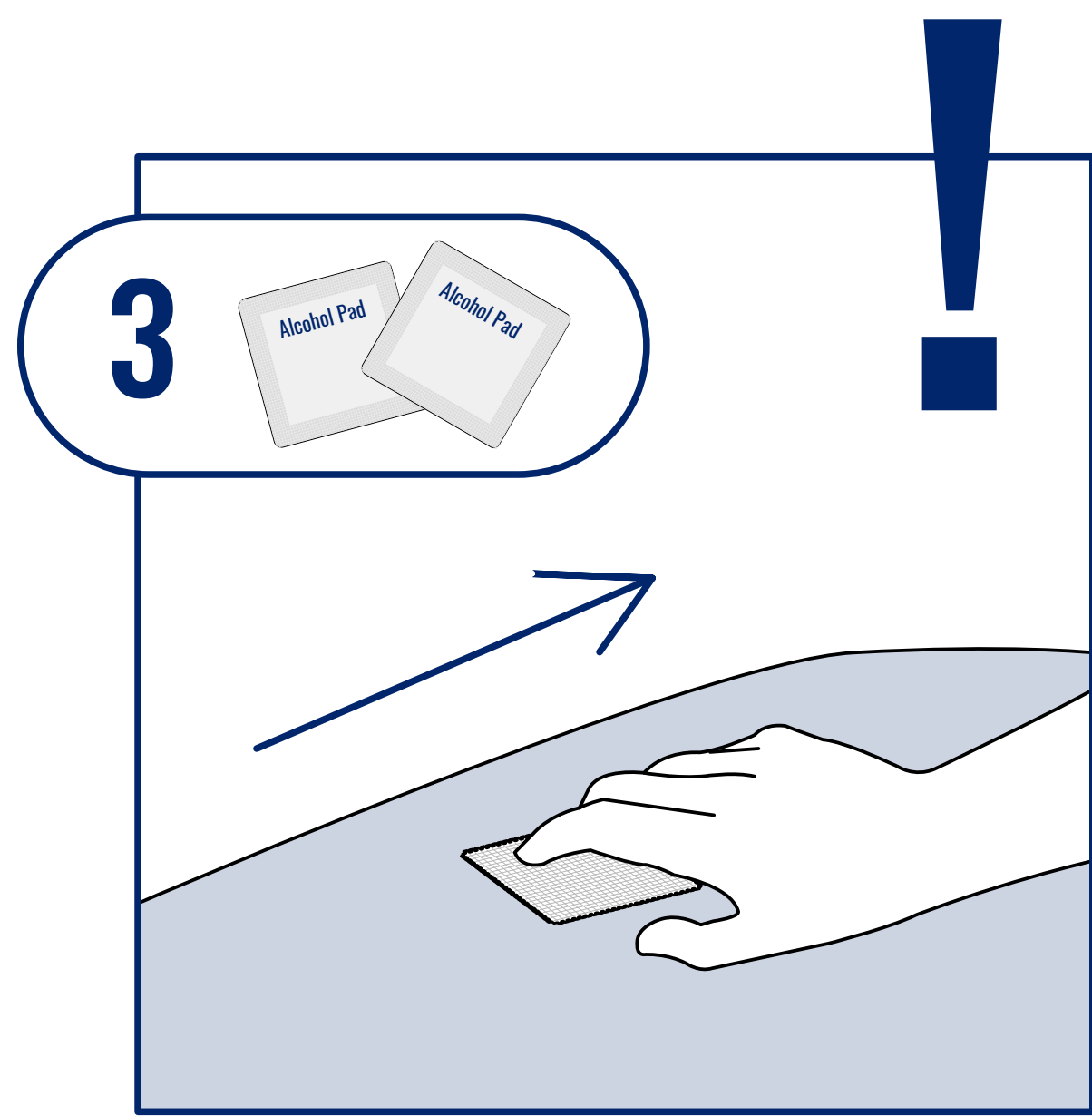
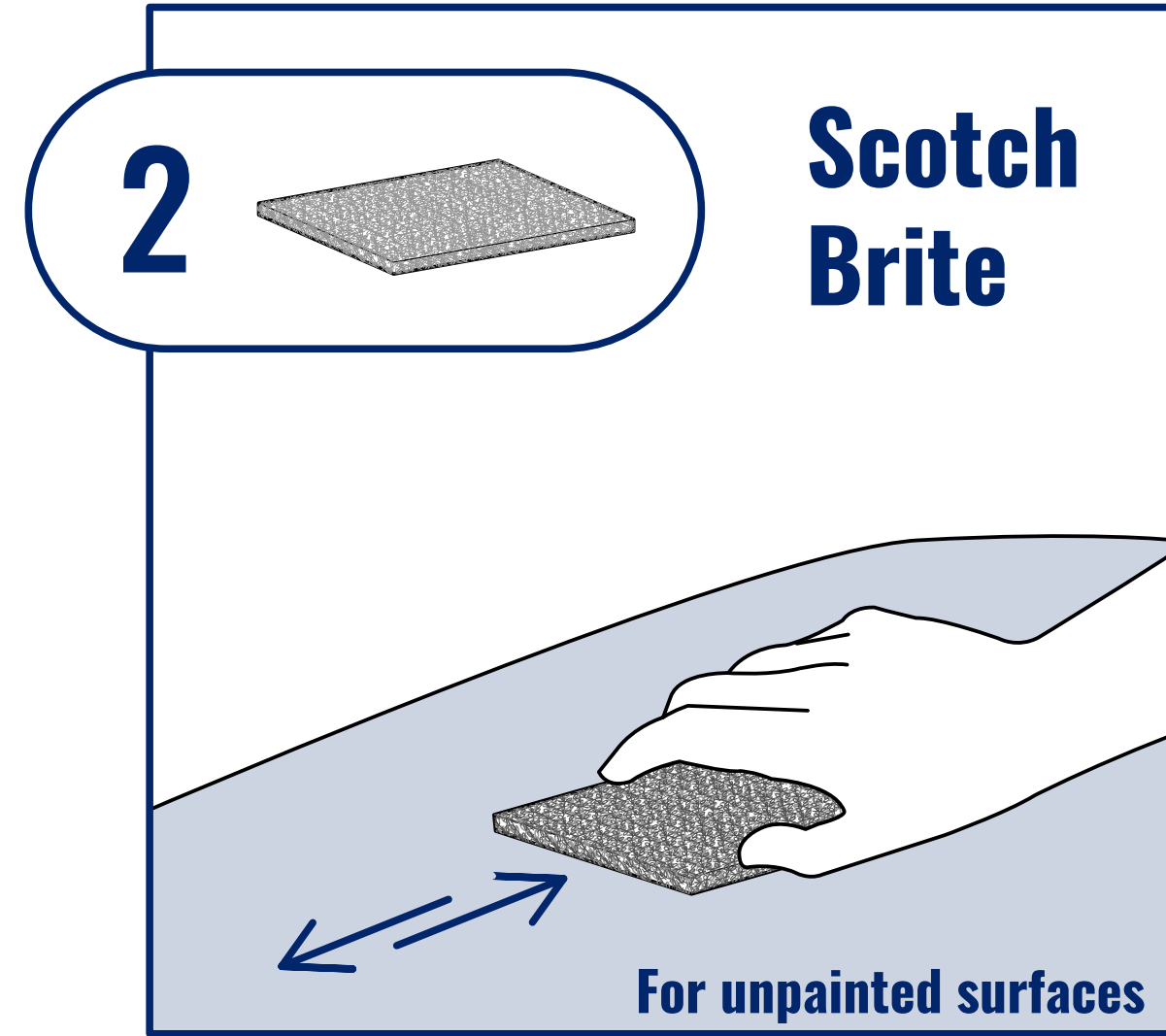

Wiring Guide

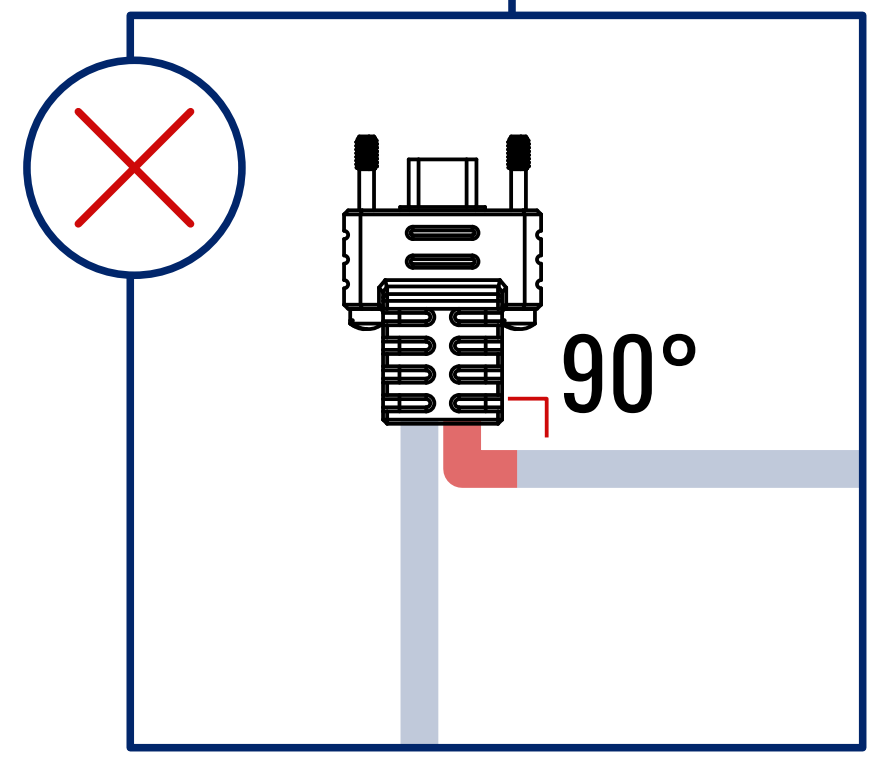
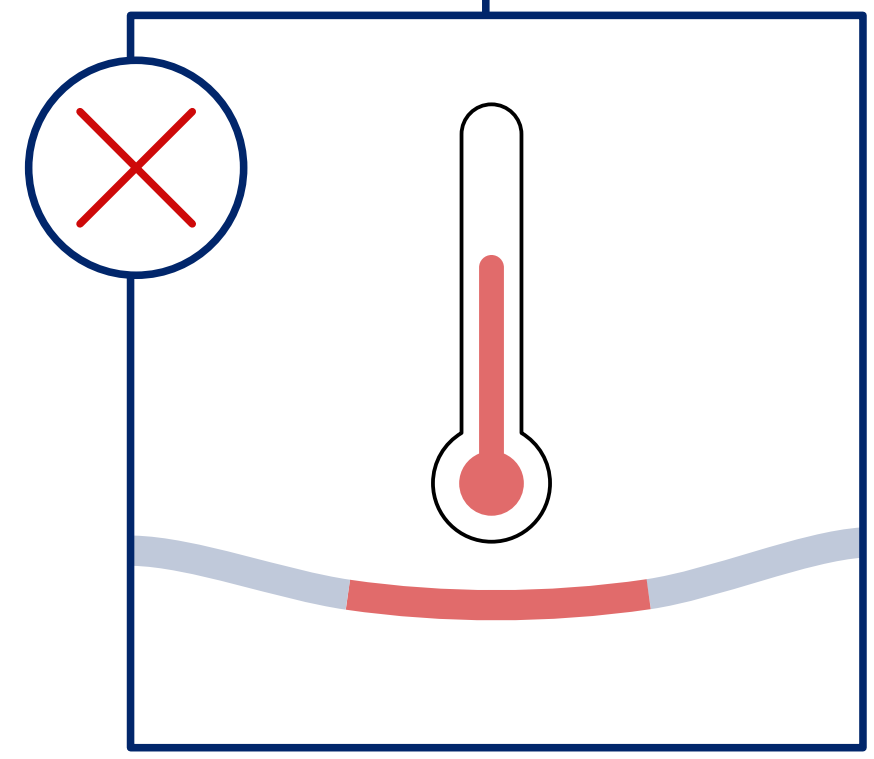
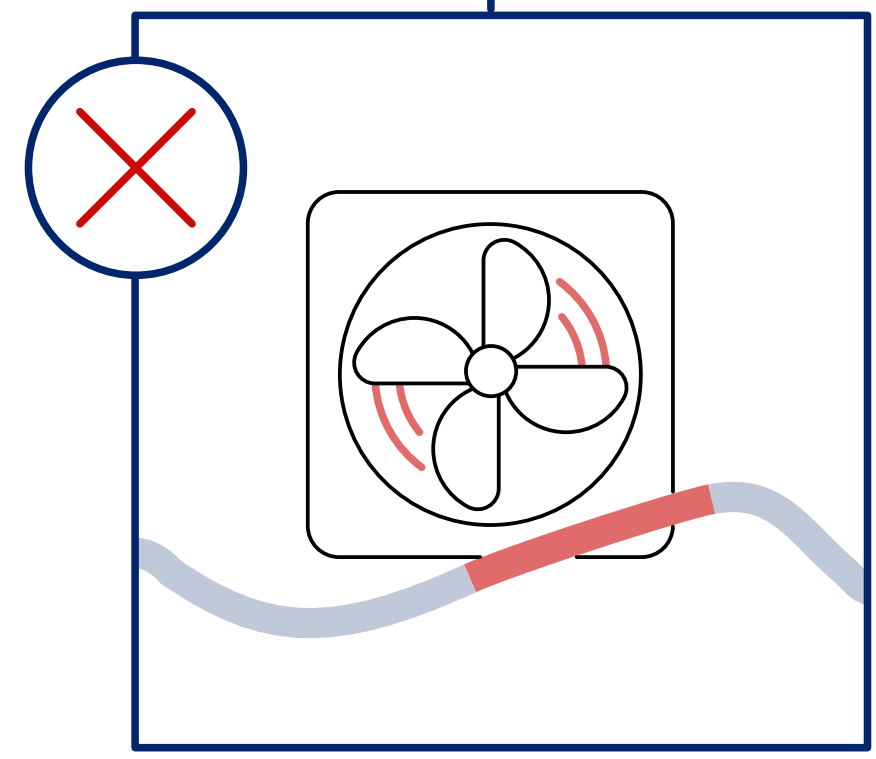
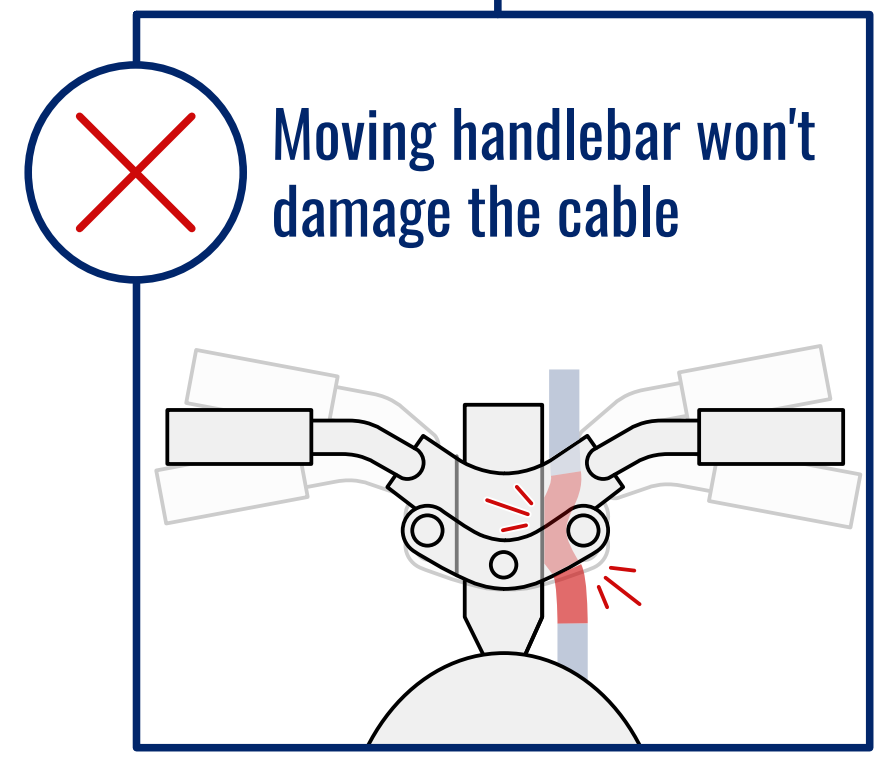
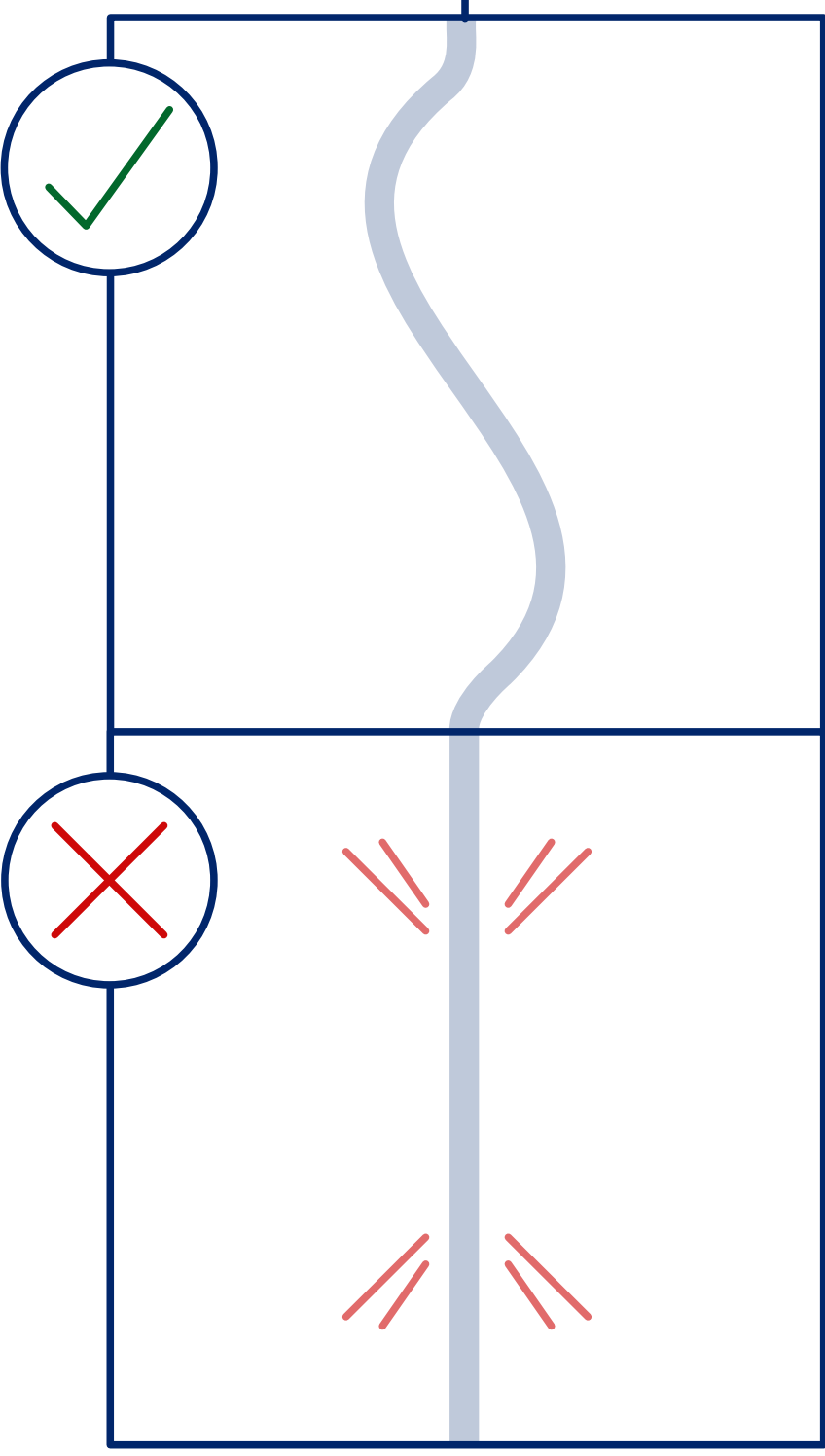
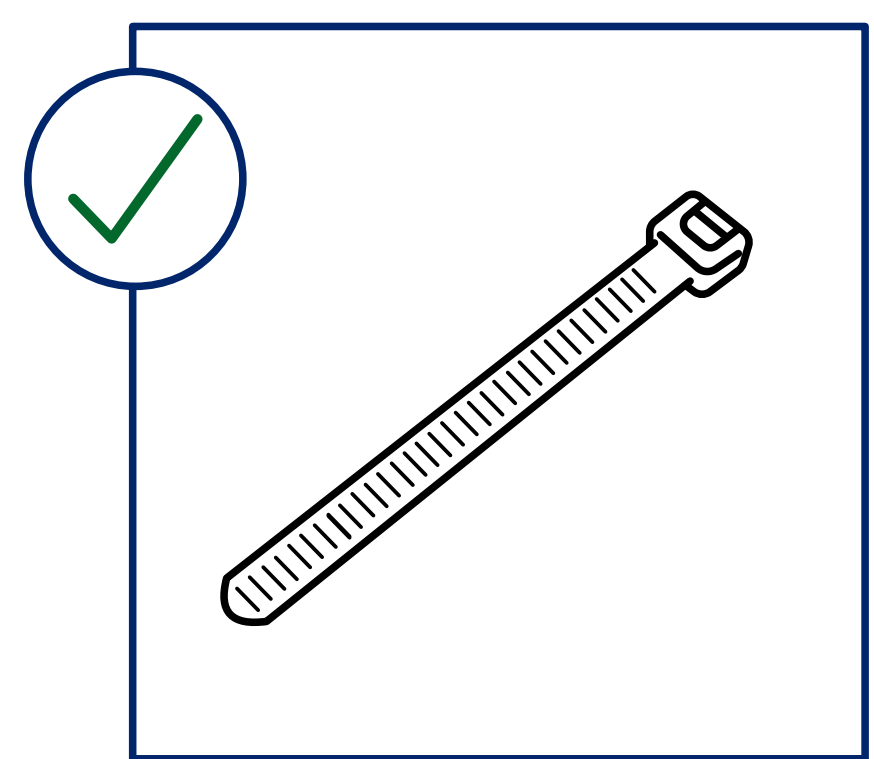
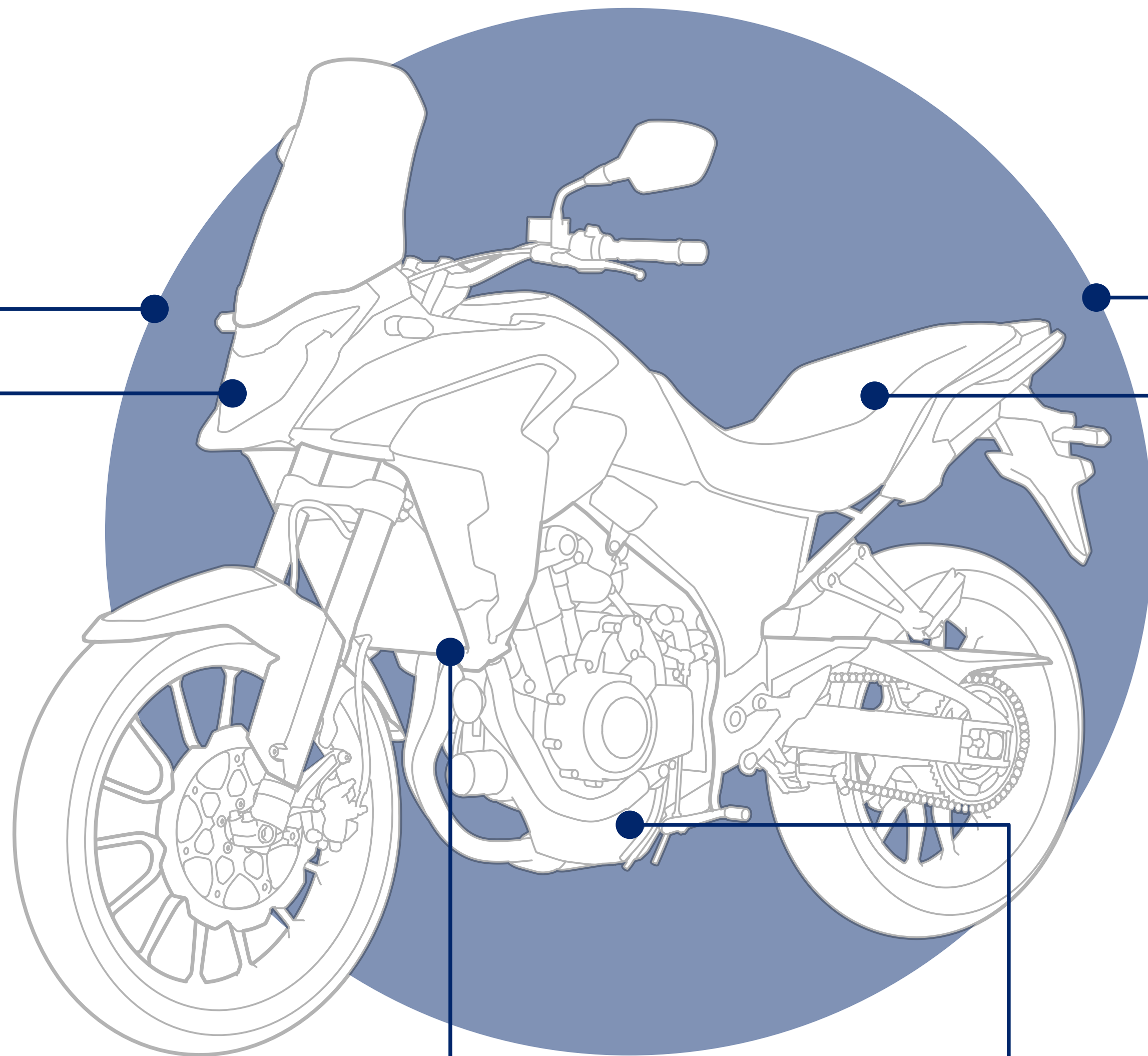

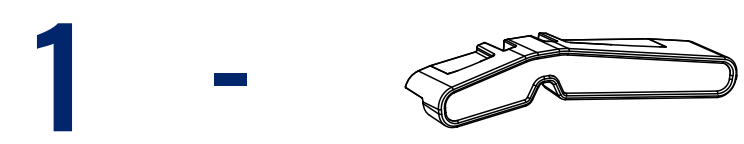

Alert Indicators

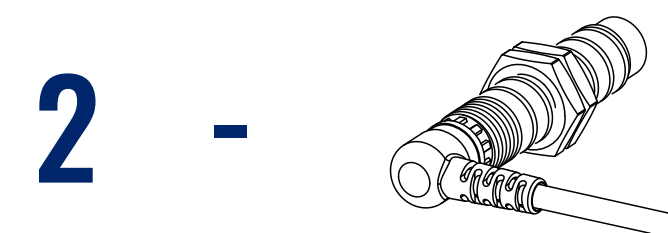

Speed sensor

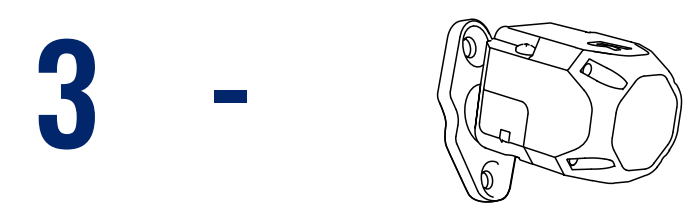

Front camera



Front cable connection



Rear camera

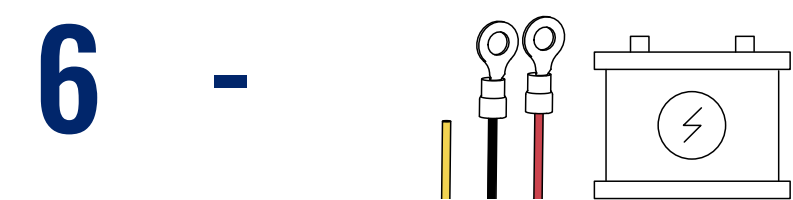

**Rear cable,
battery connection**



GPS

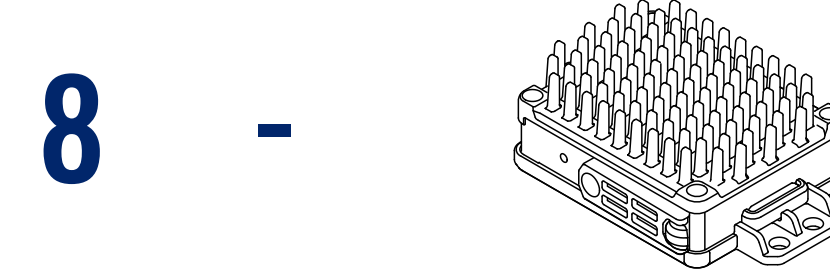

Main Unit

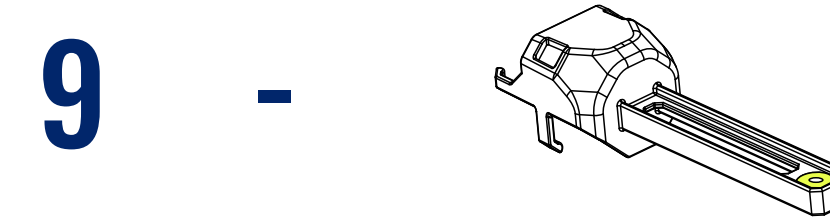

Leveling



Validation



Mobile app

1 Left Indicator Right Indicator

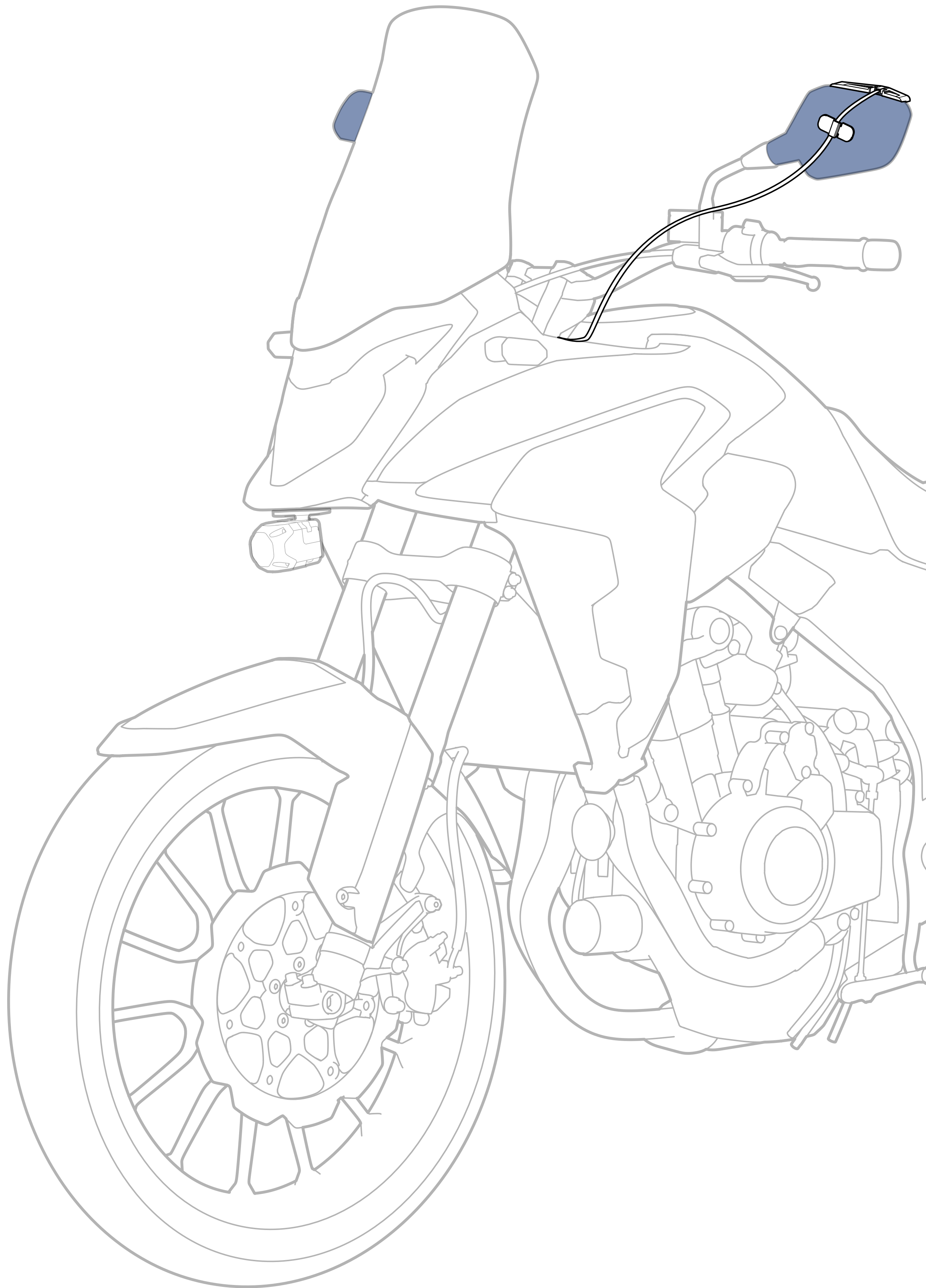
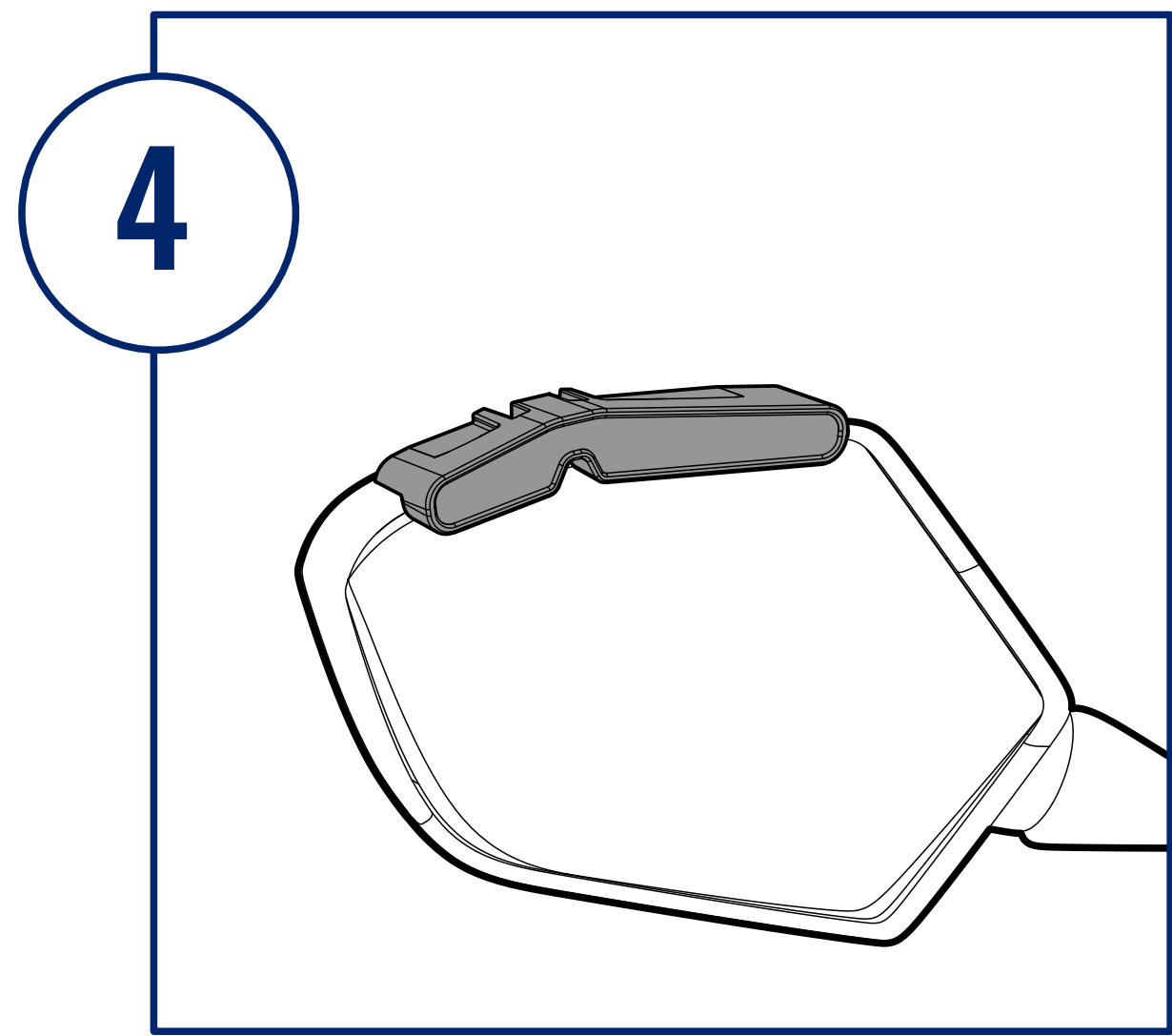
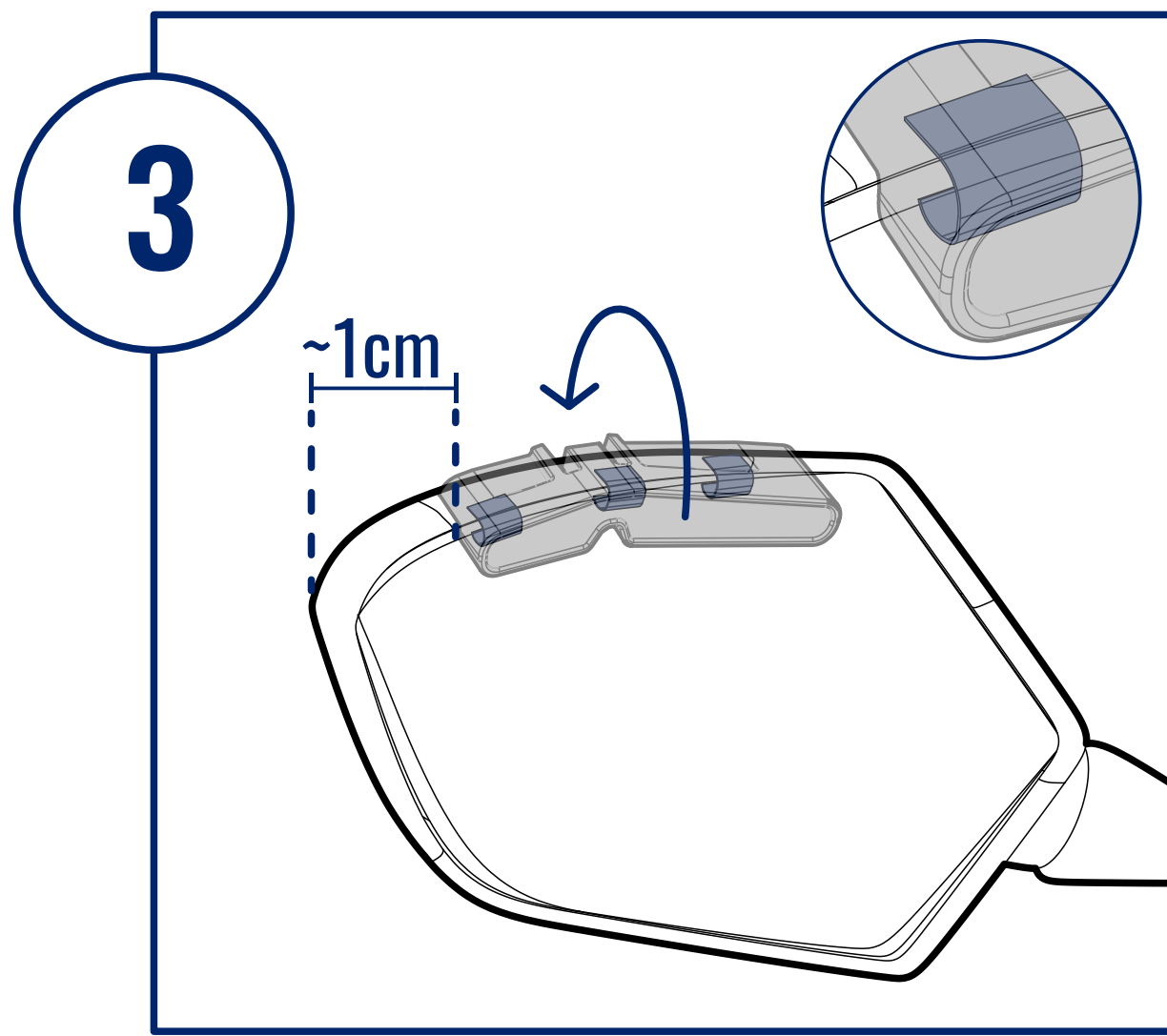
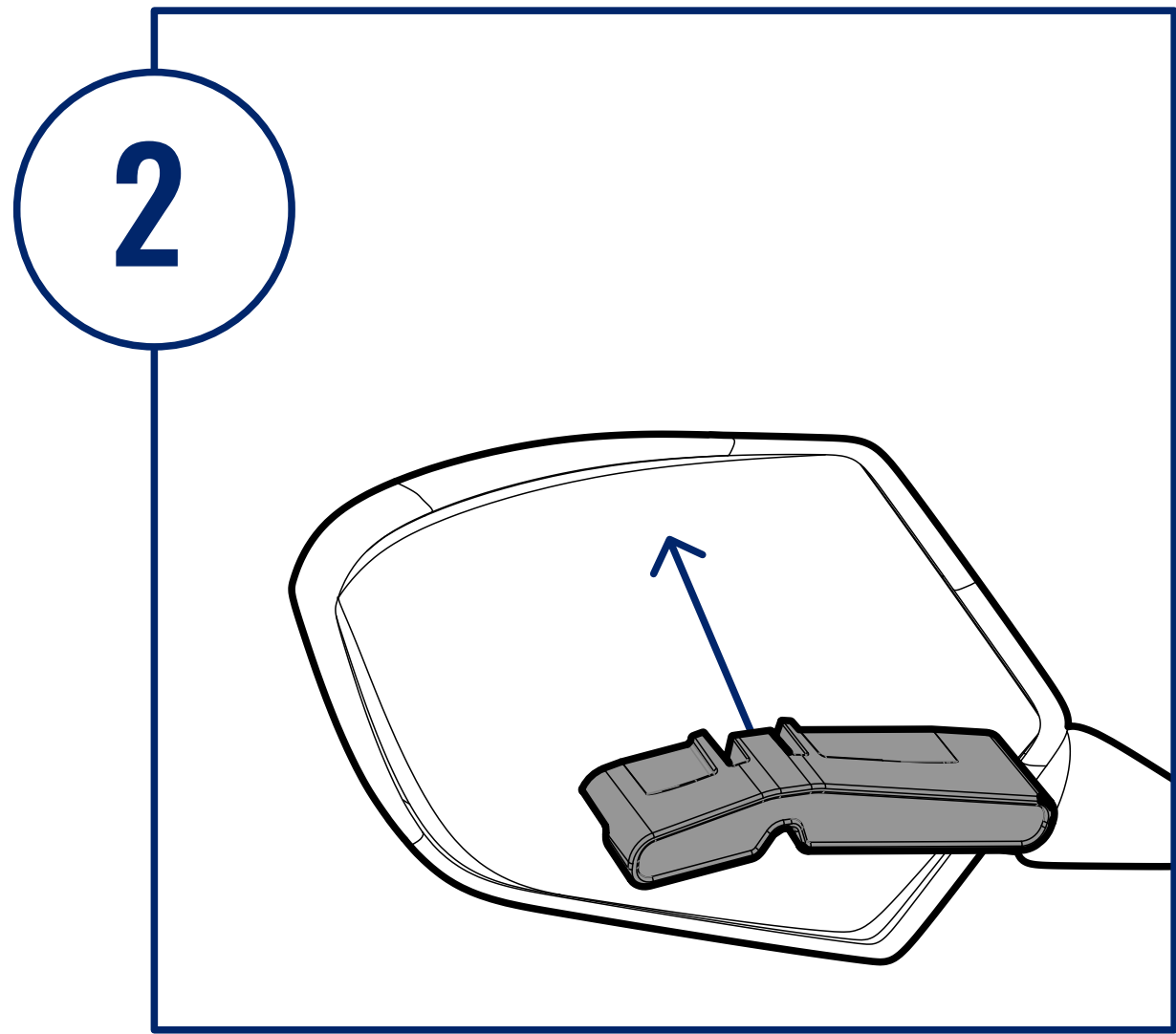
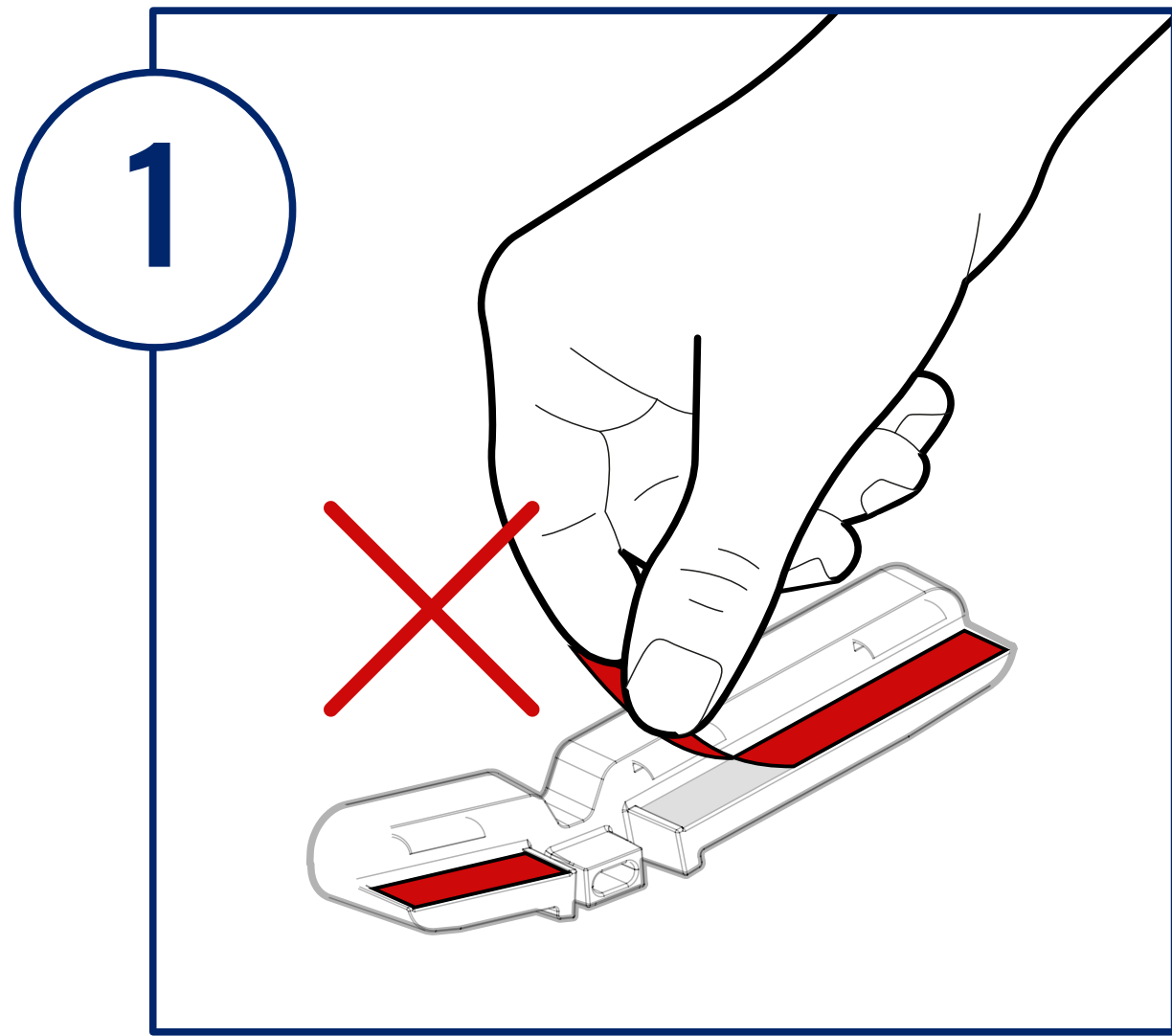
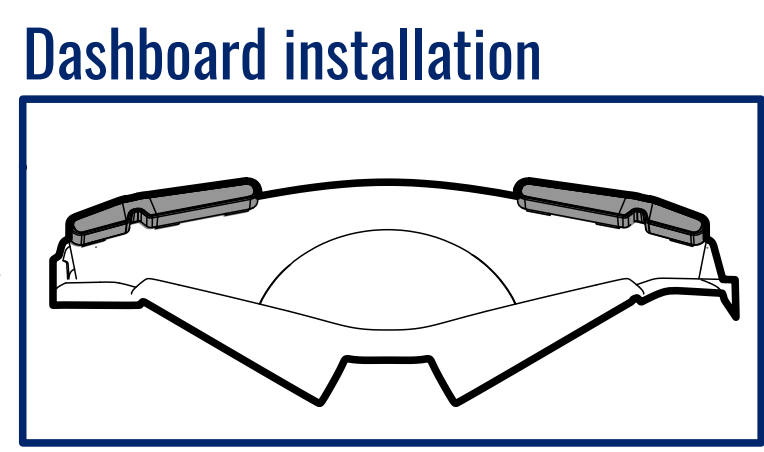
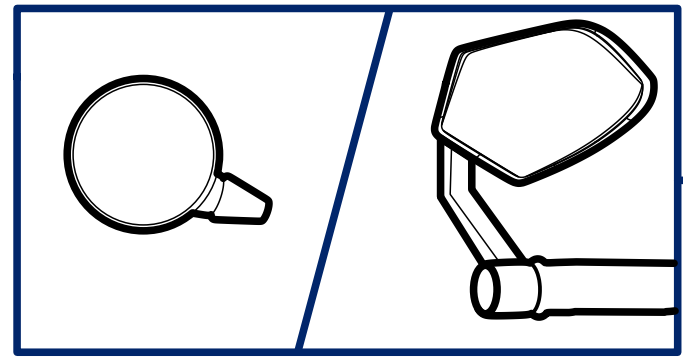
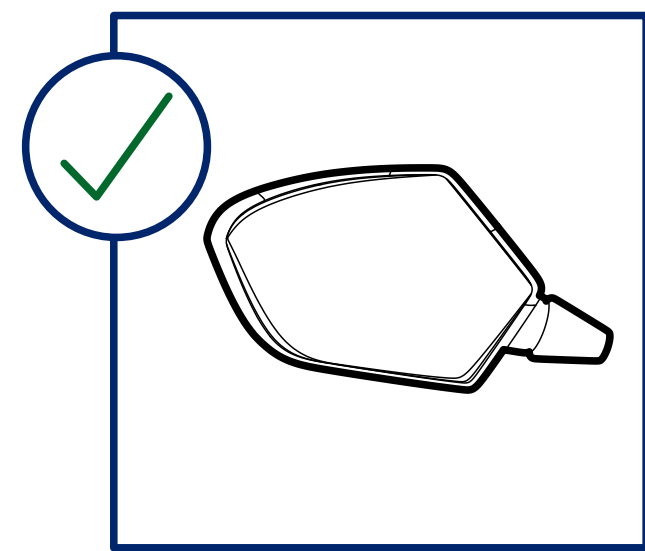
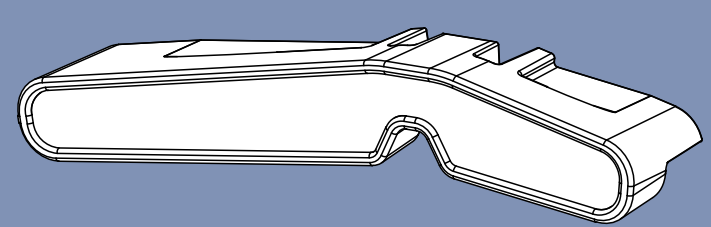
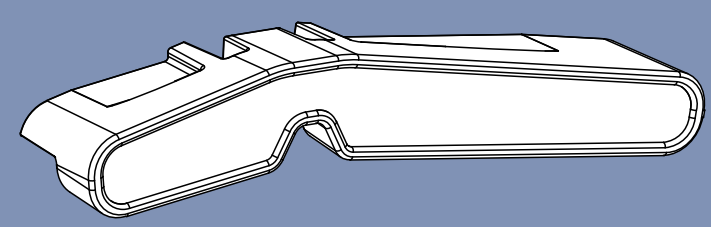

1

Left Indicator

Right Indicator

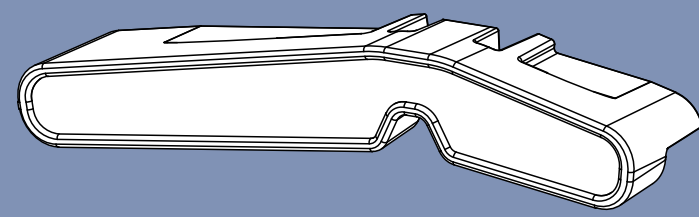
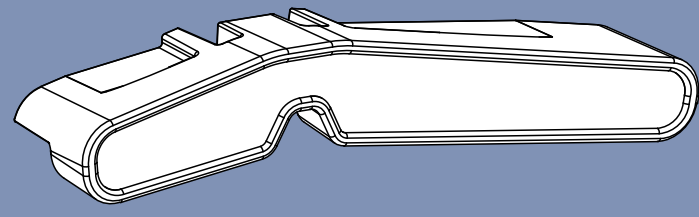

5

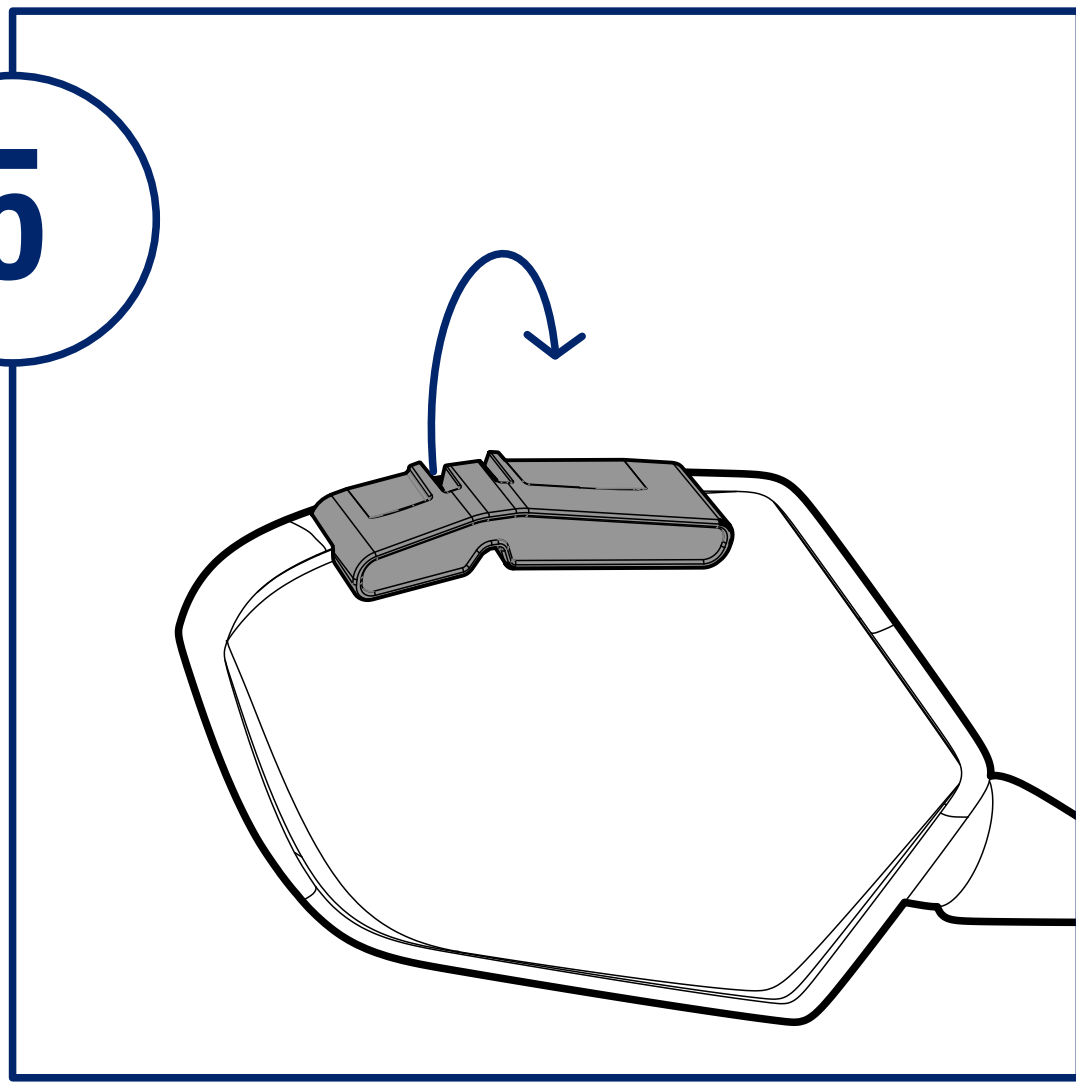

6

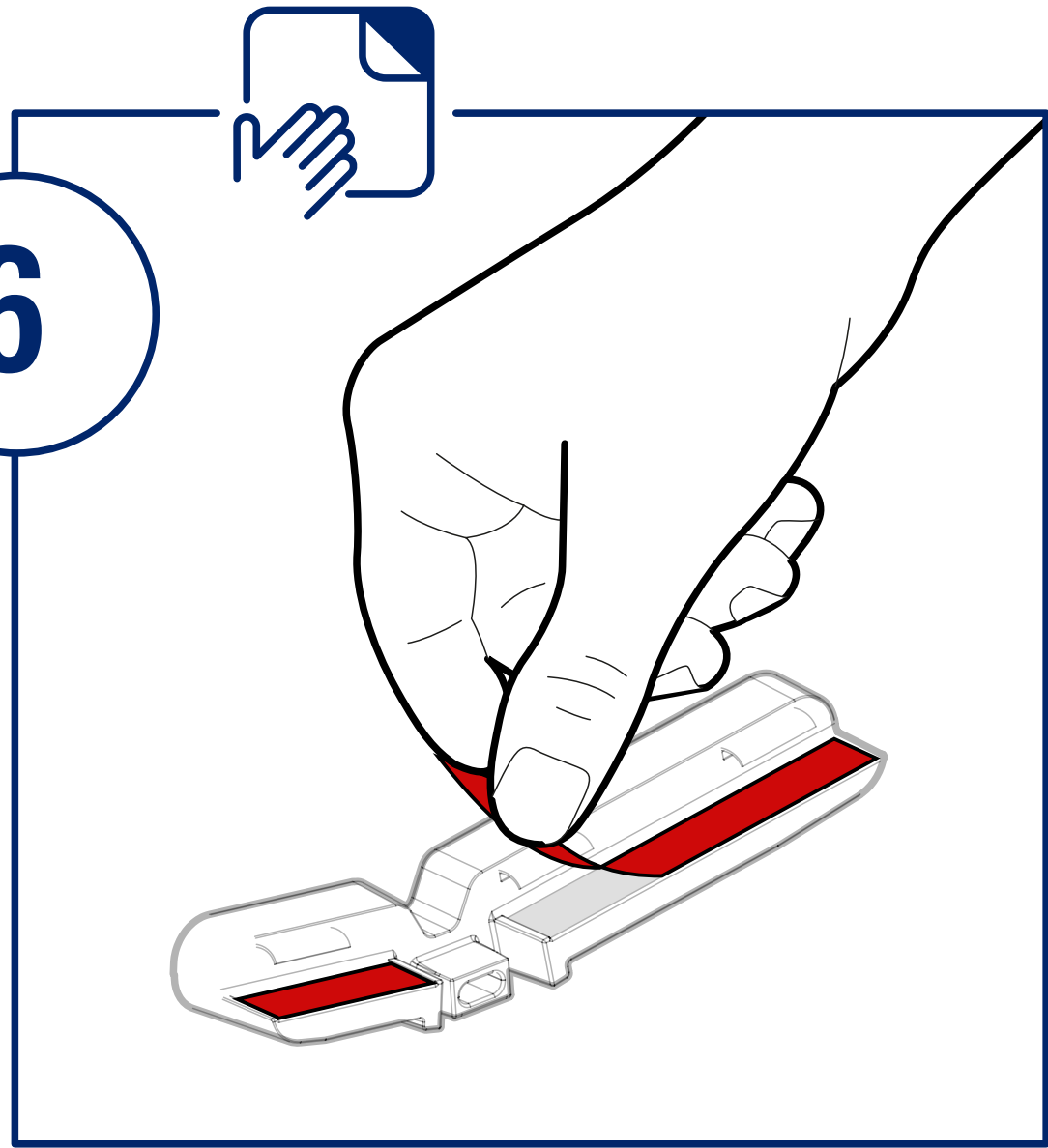

7

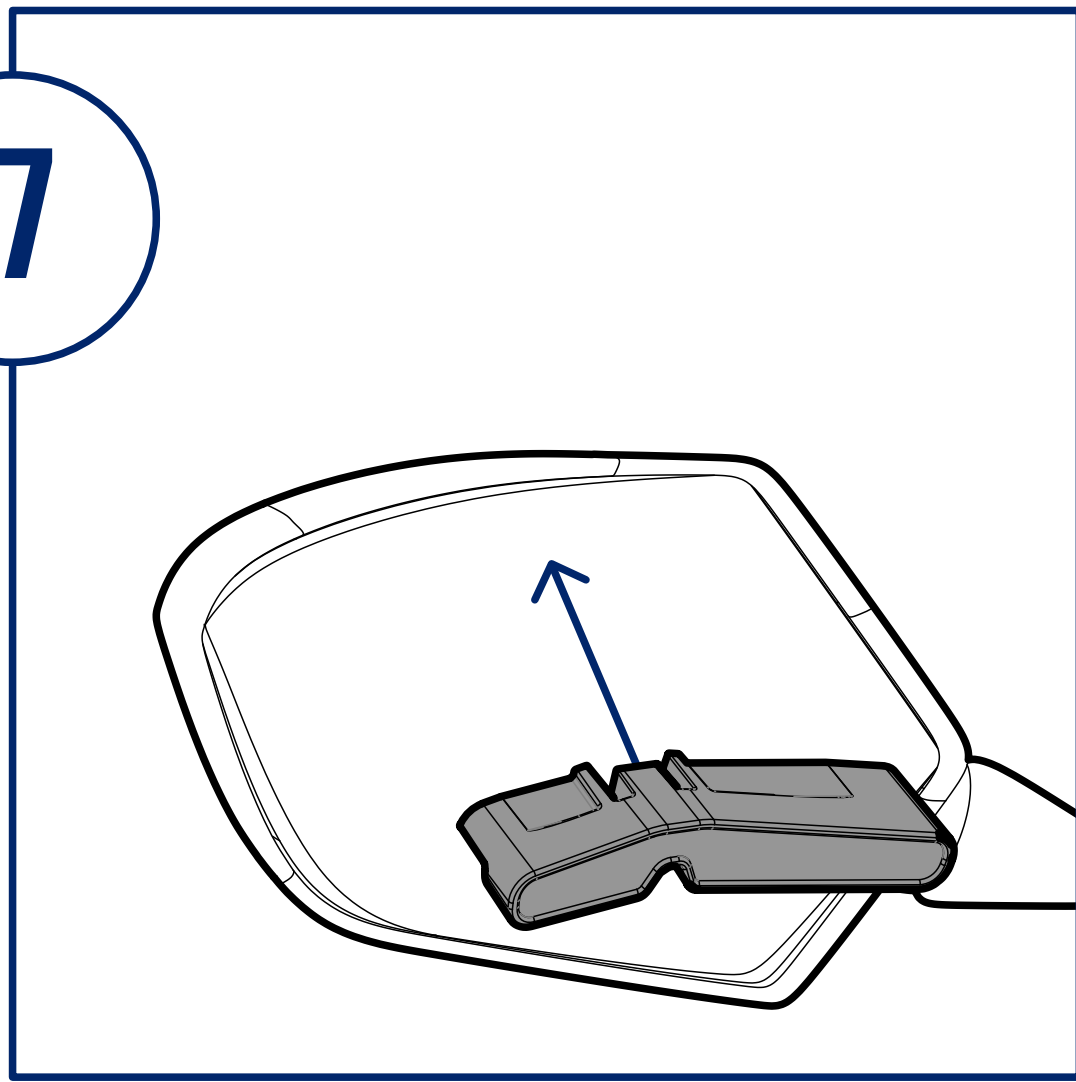

8

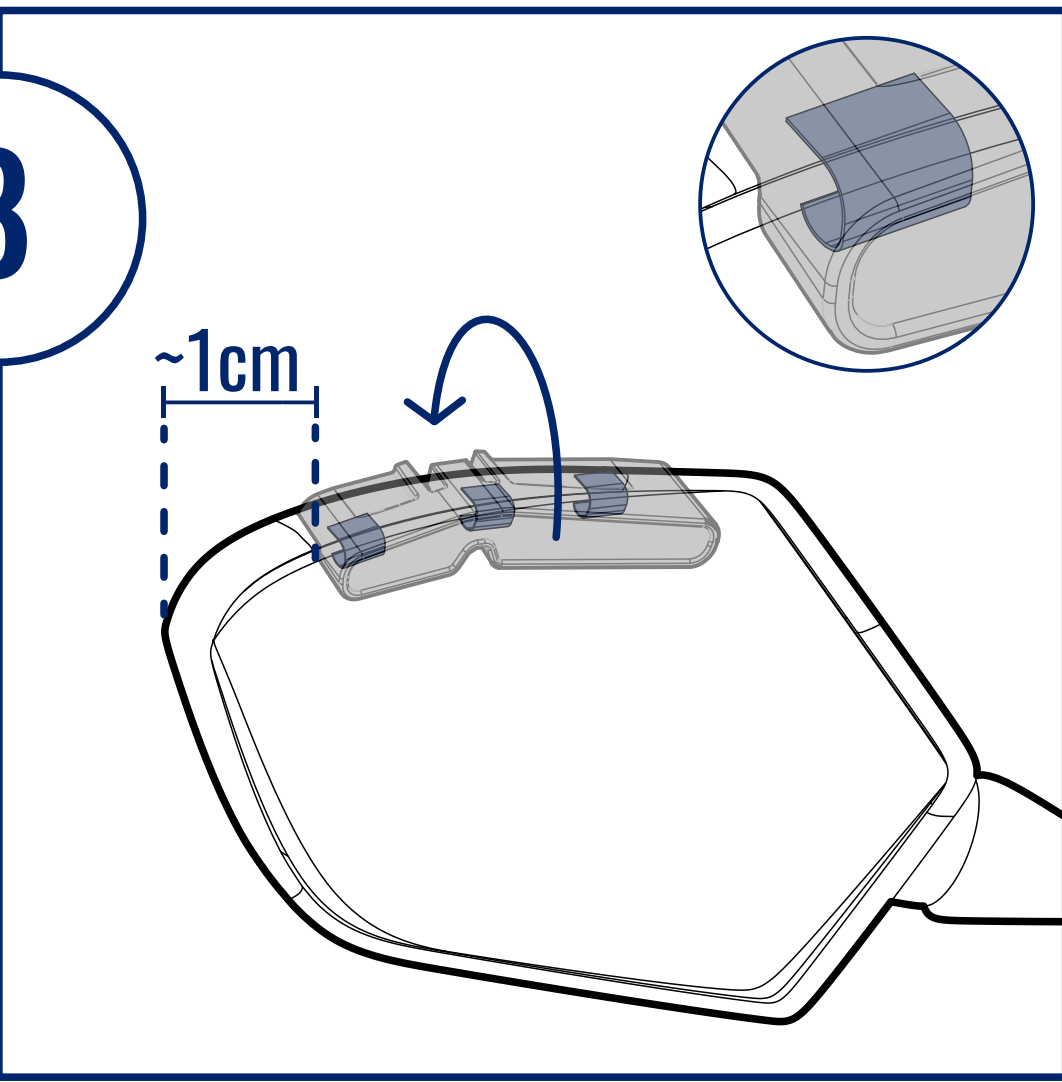

9

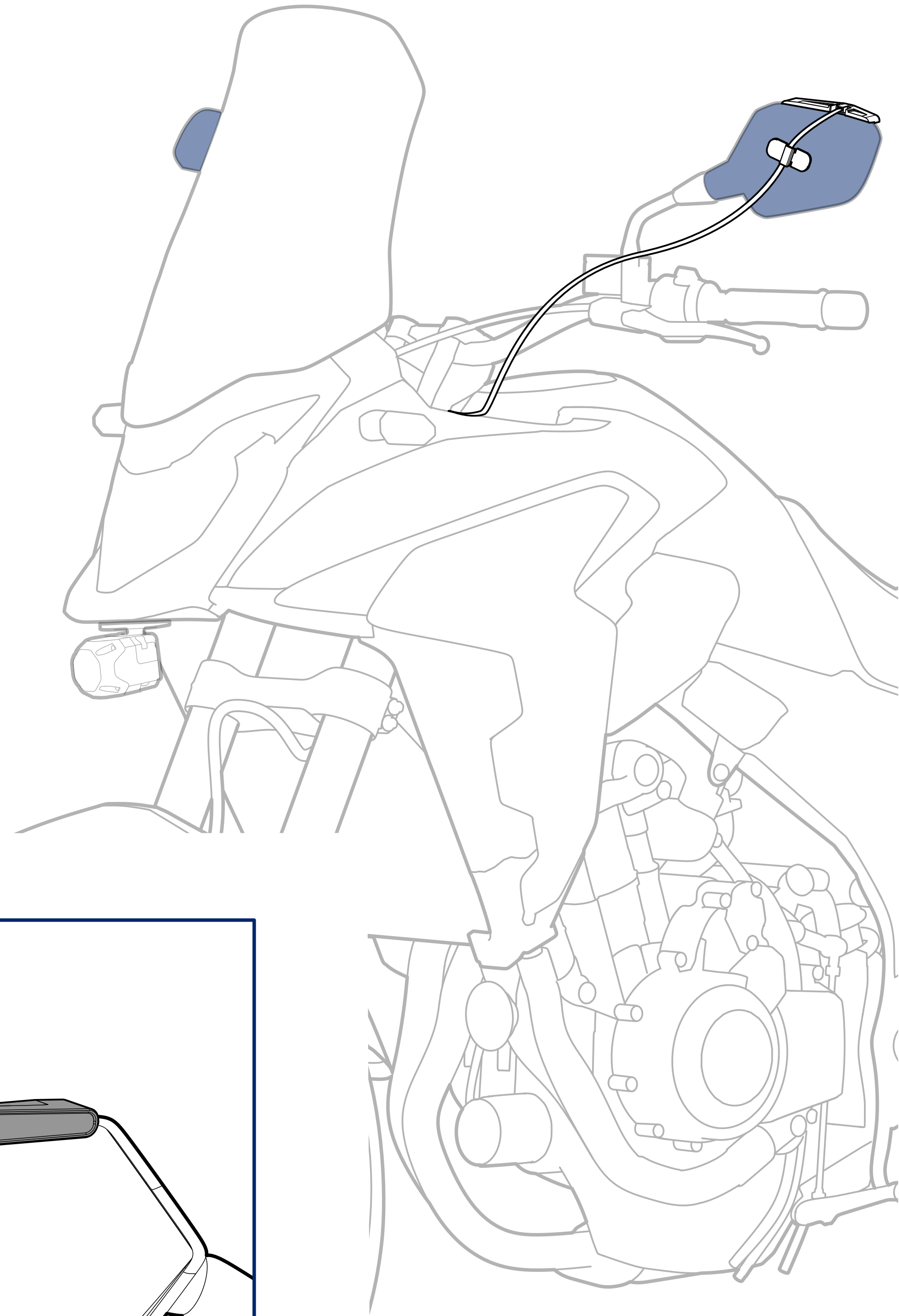
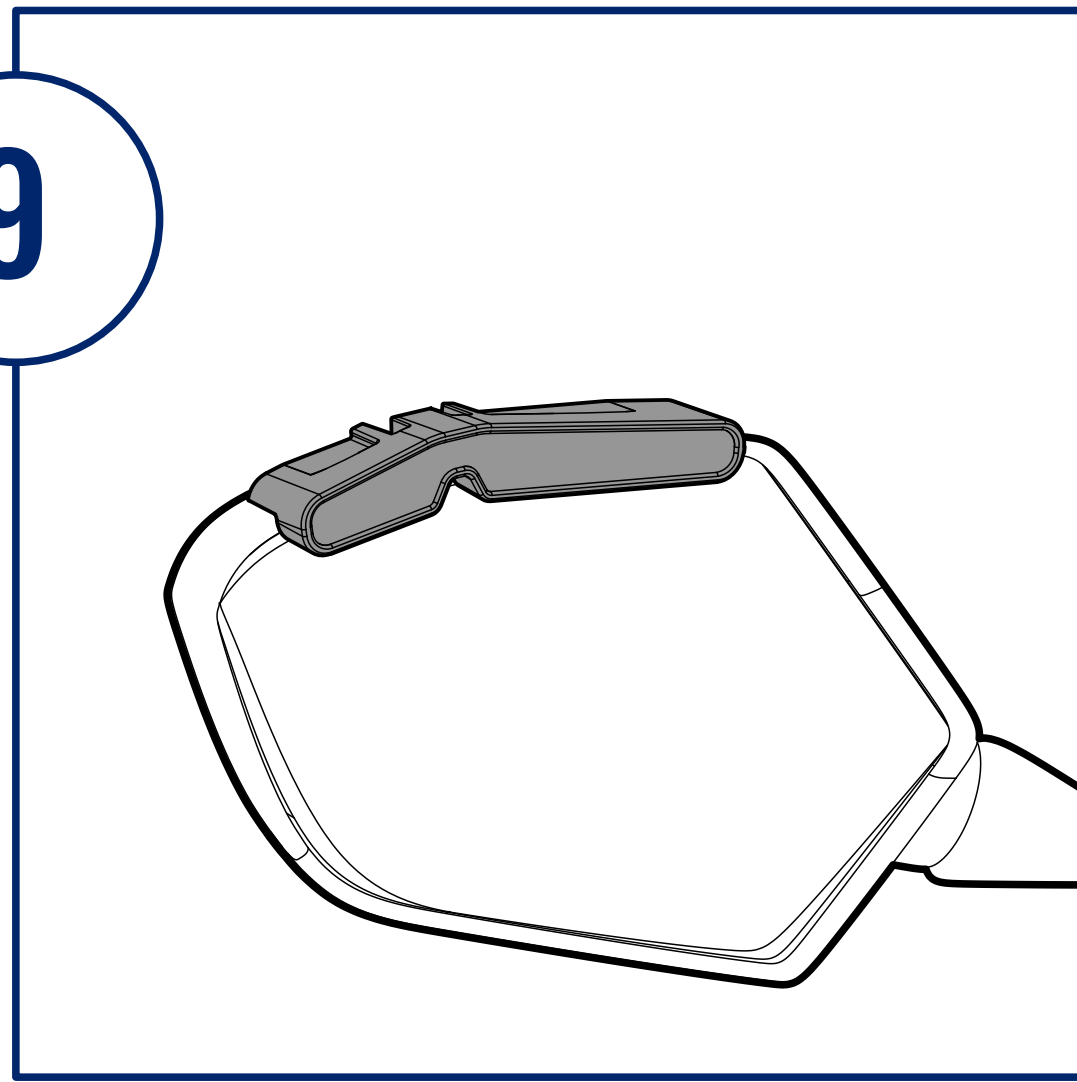

1.A

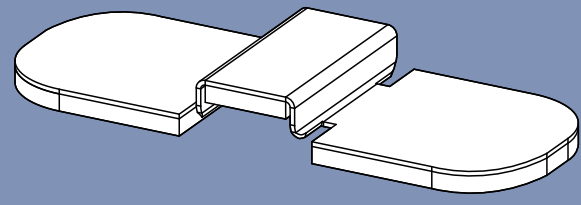

X2 R/L

Bend to shape



10

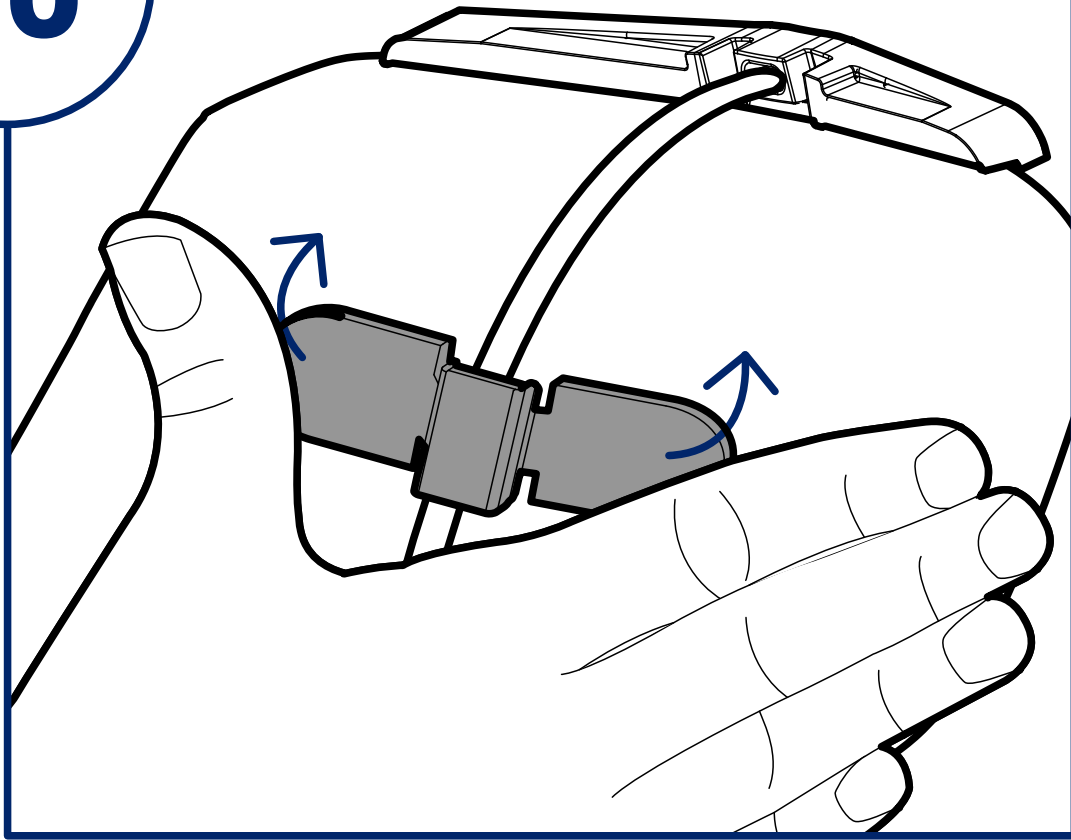

11

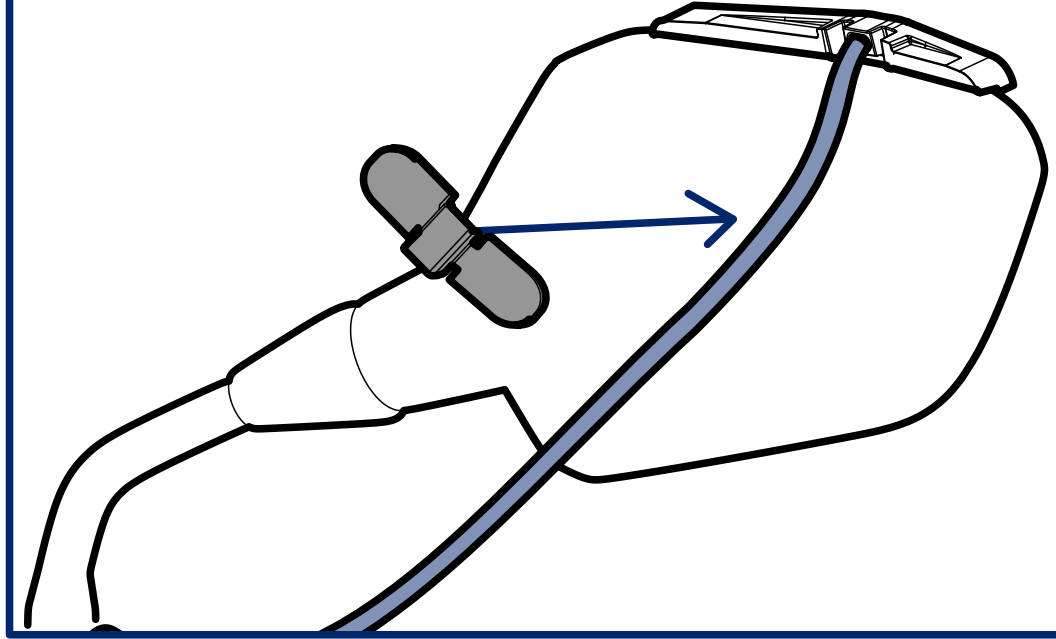

12

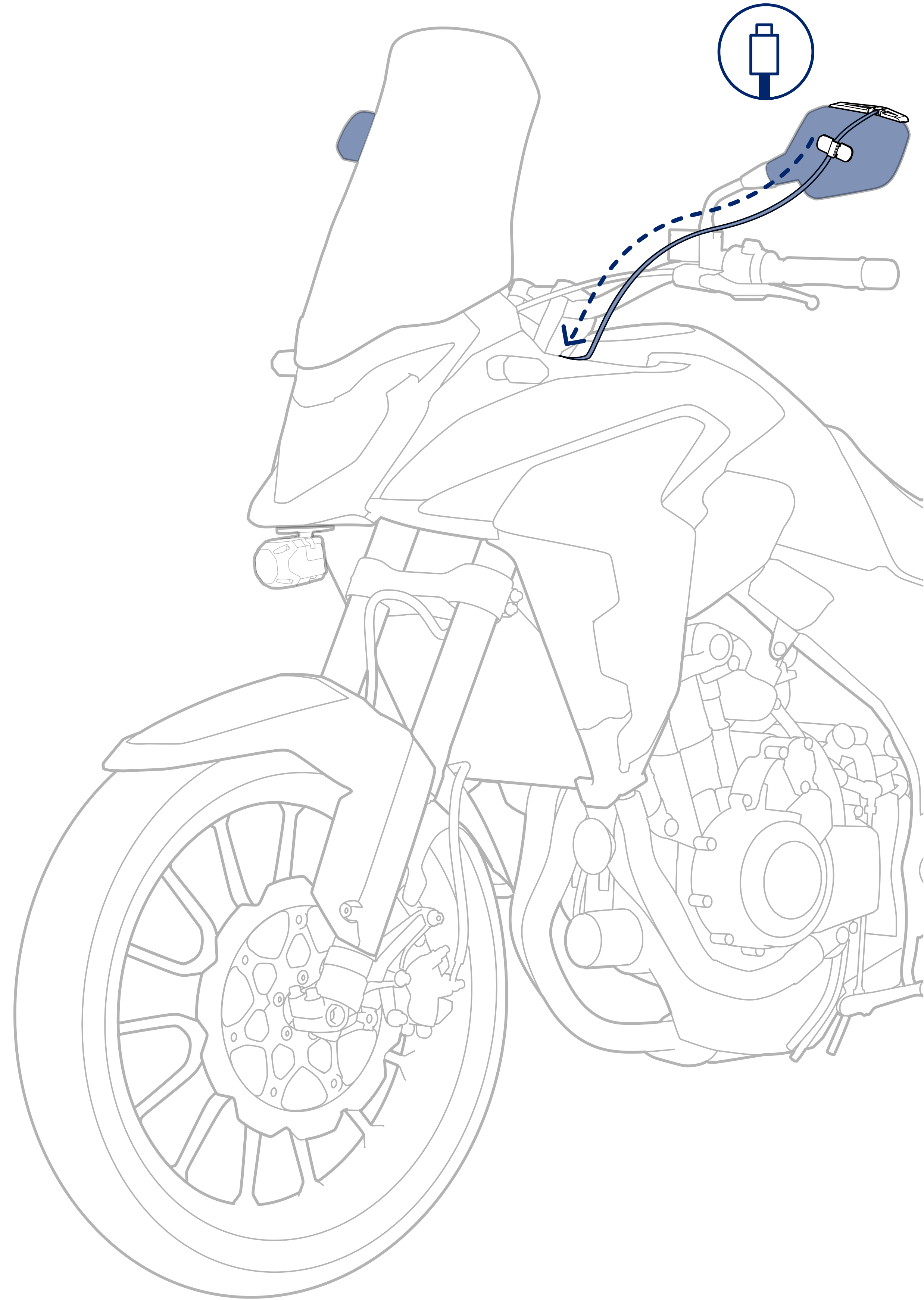
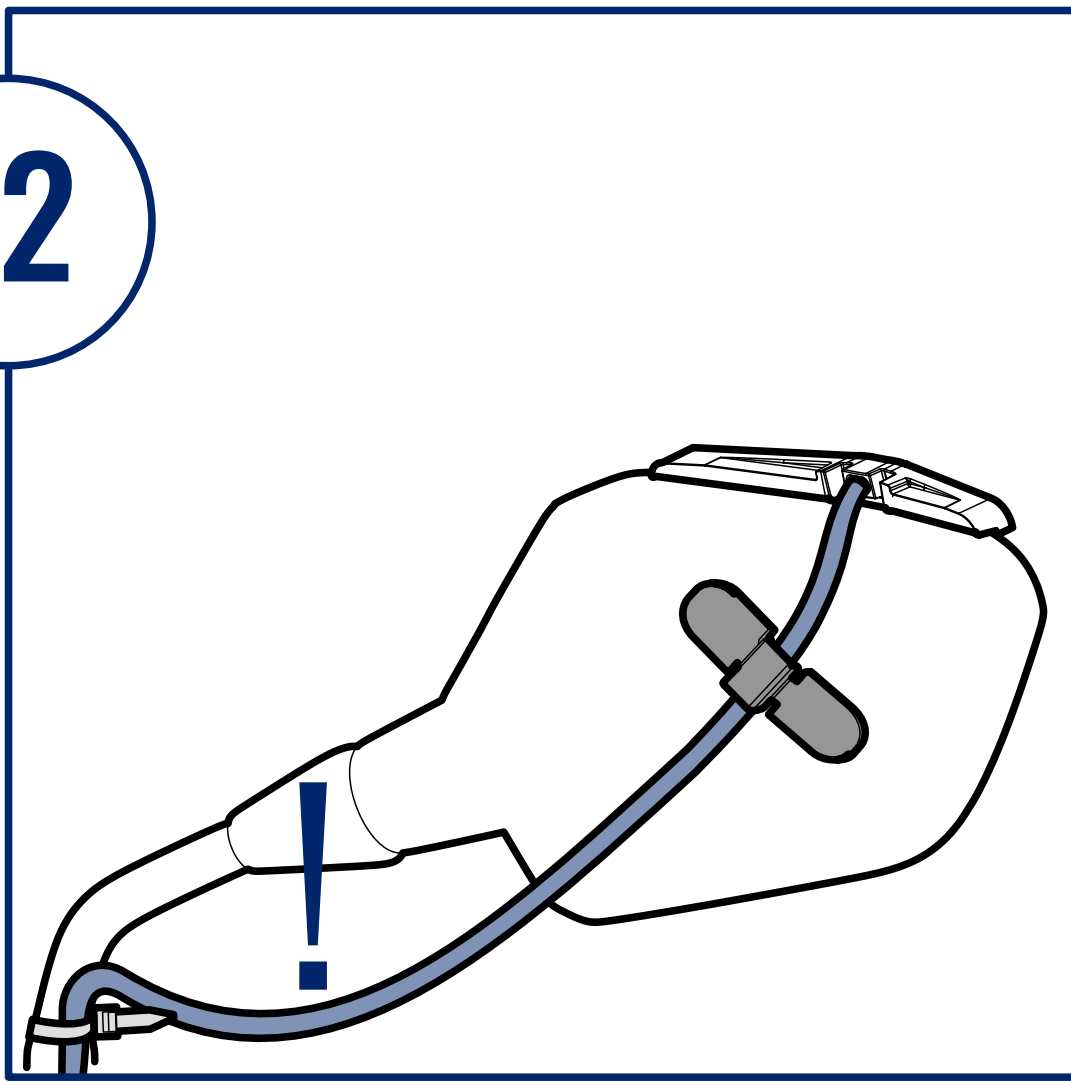

1.B

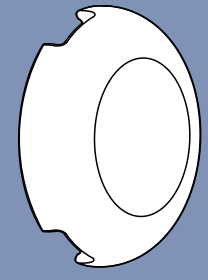

X2 R/L

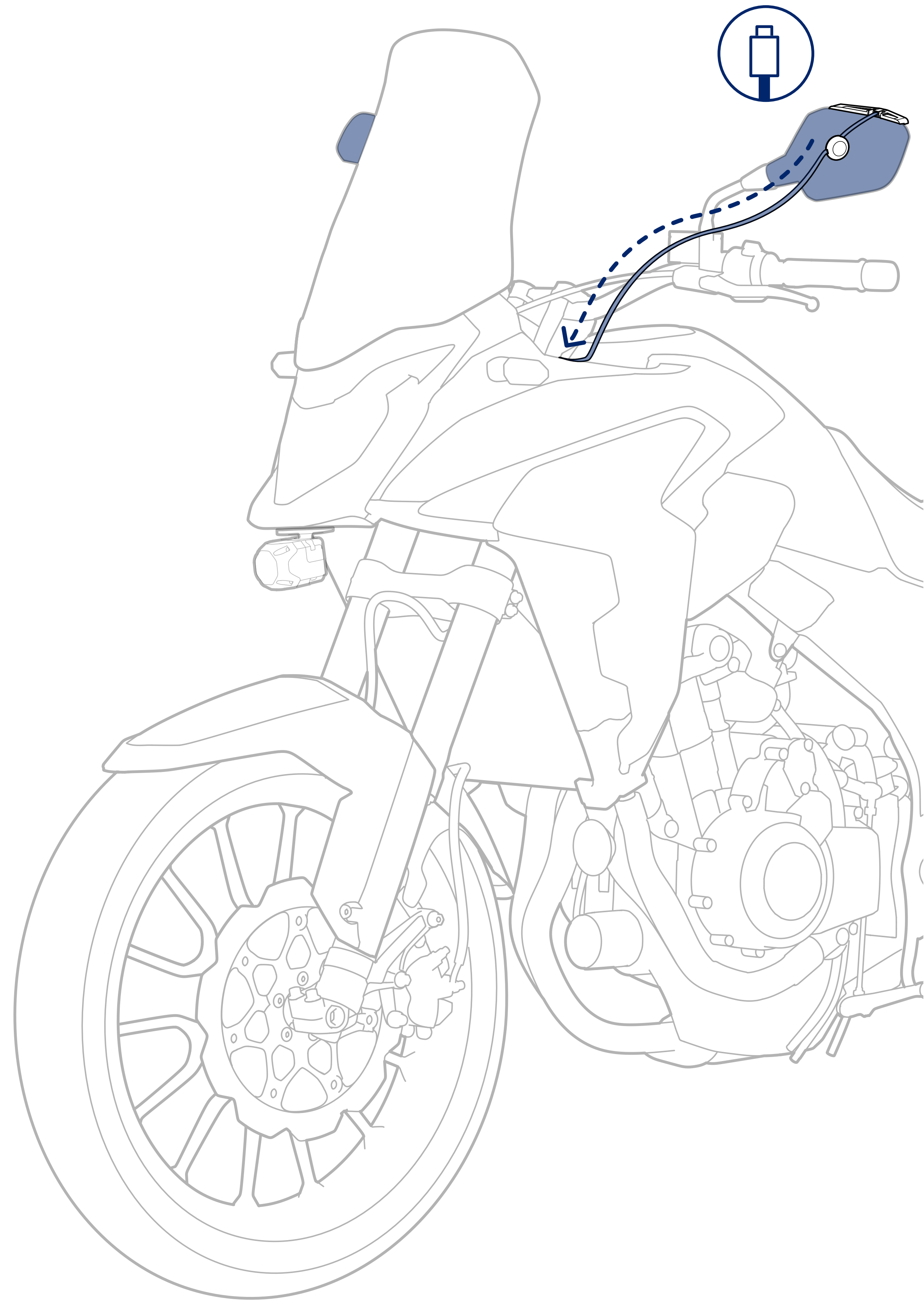
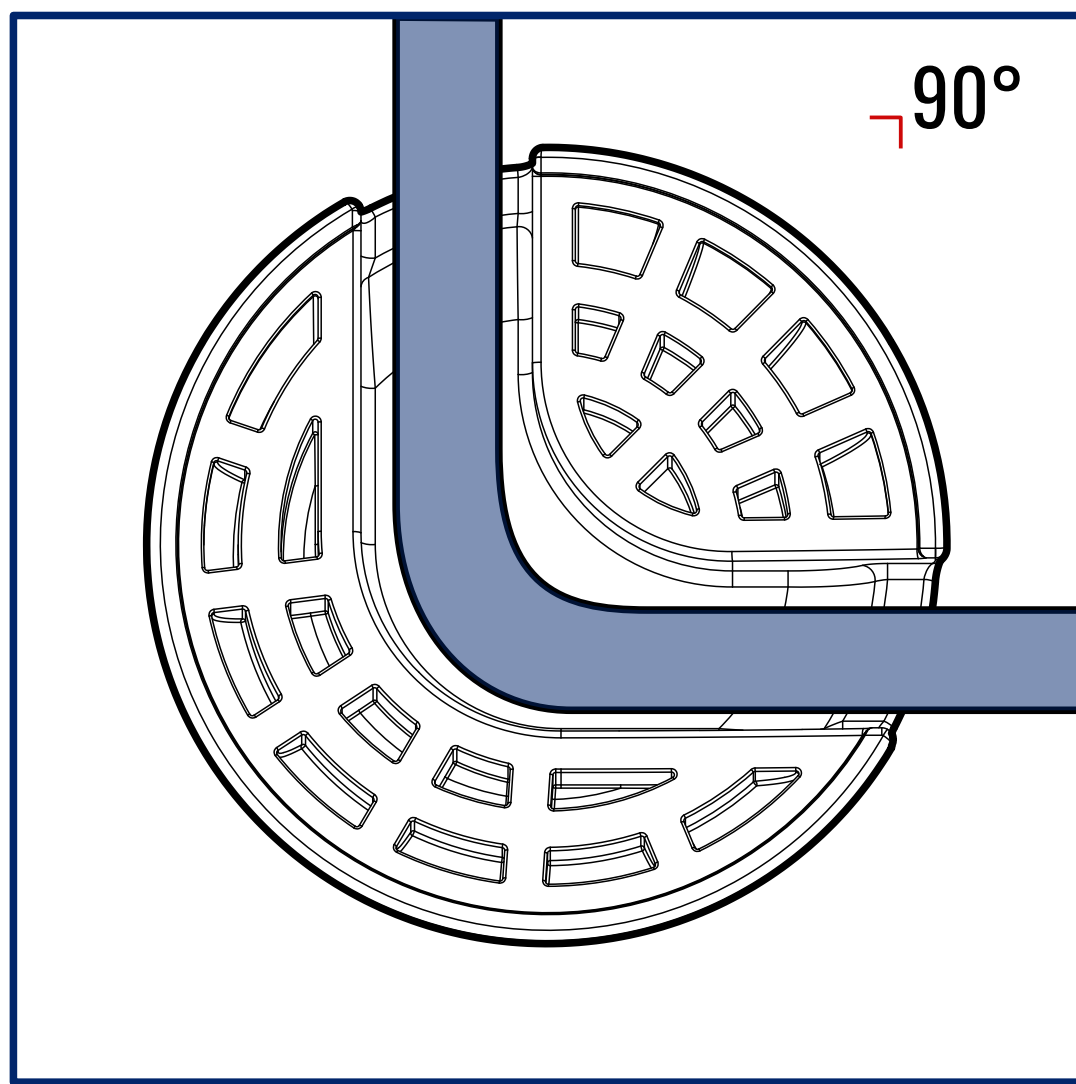
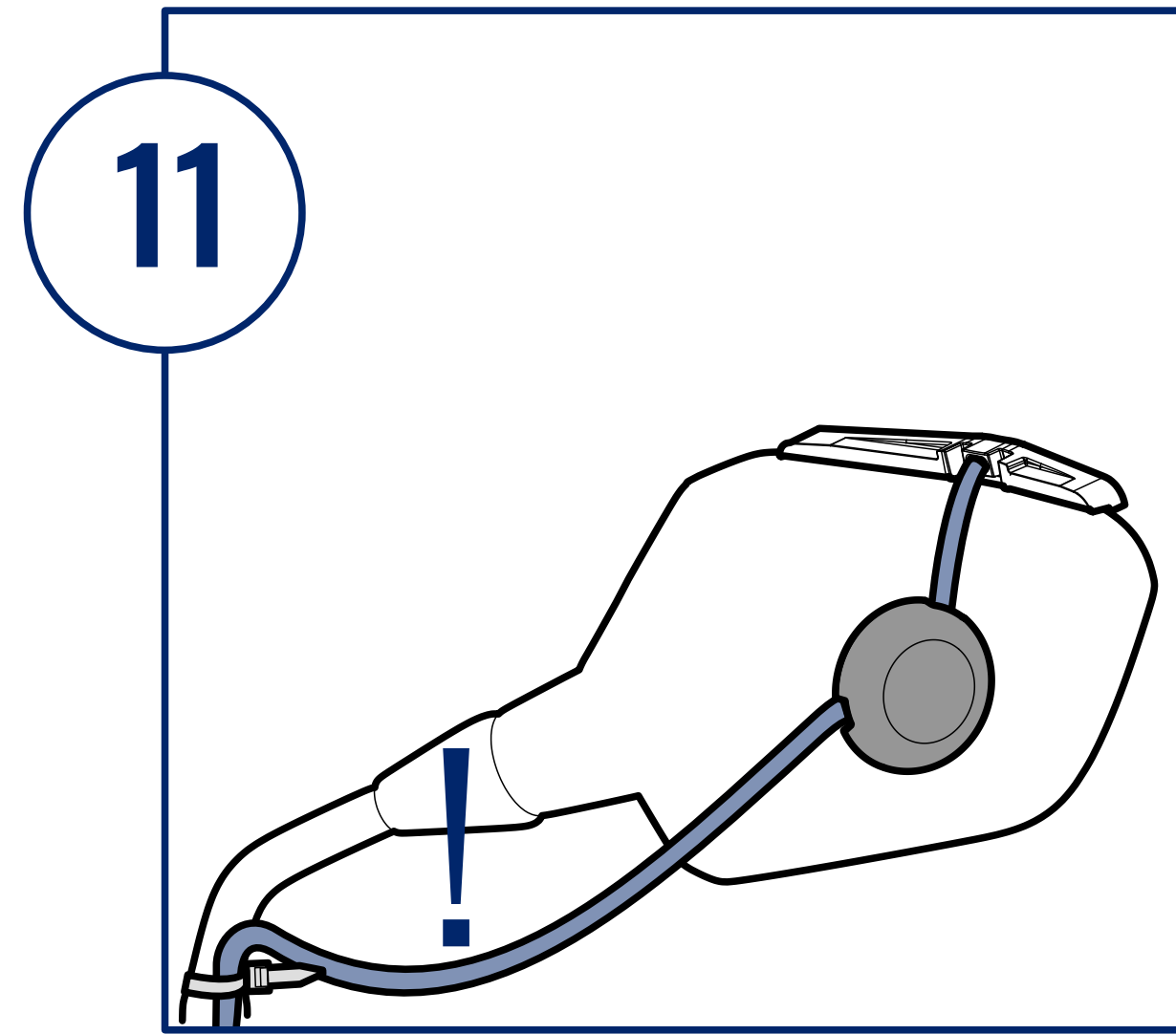
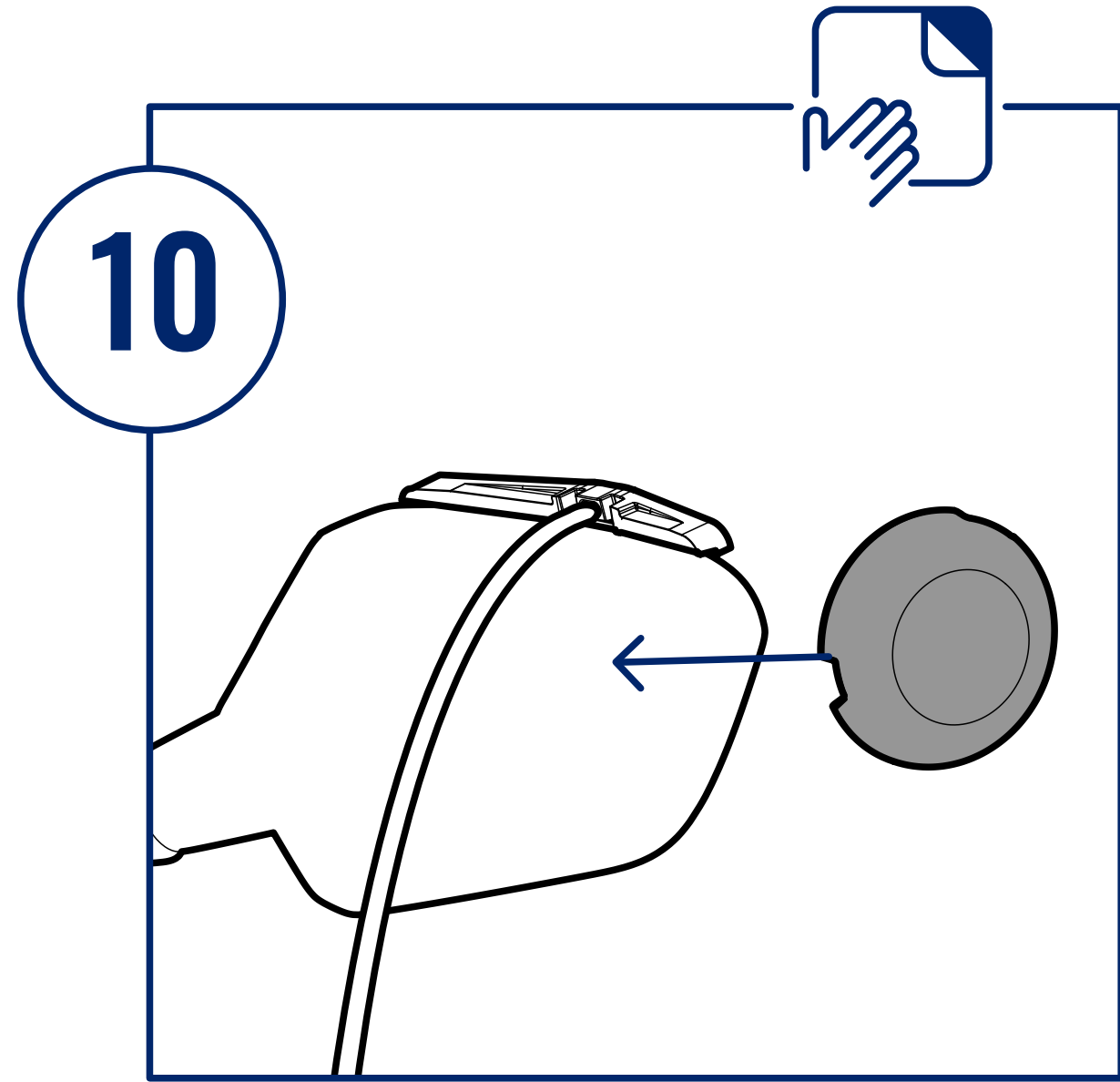

2

i

Find location

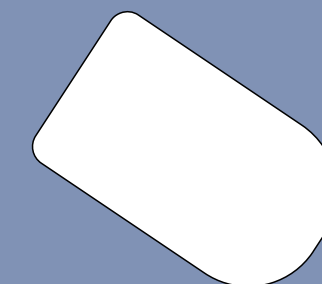
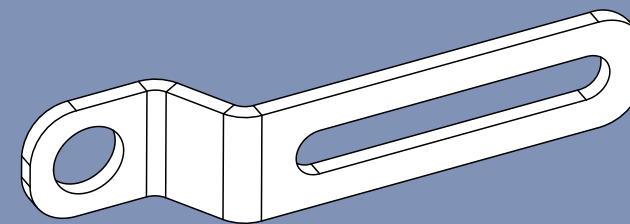
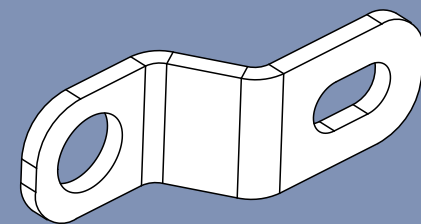
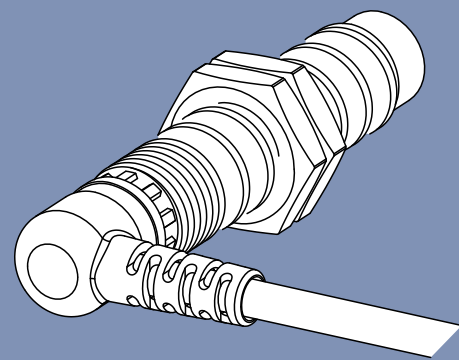

A1

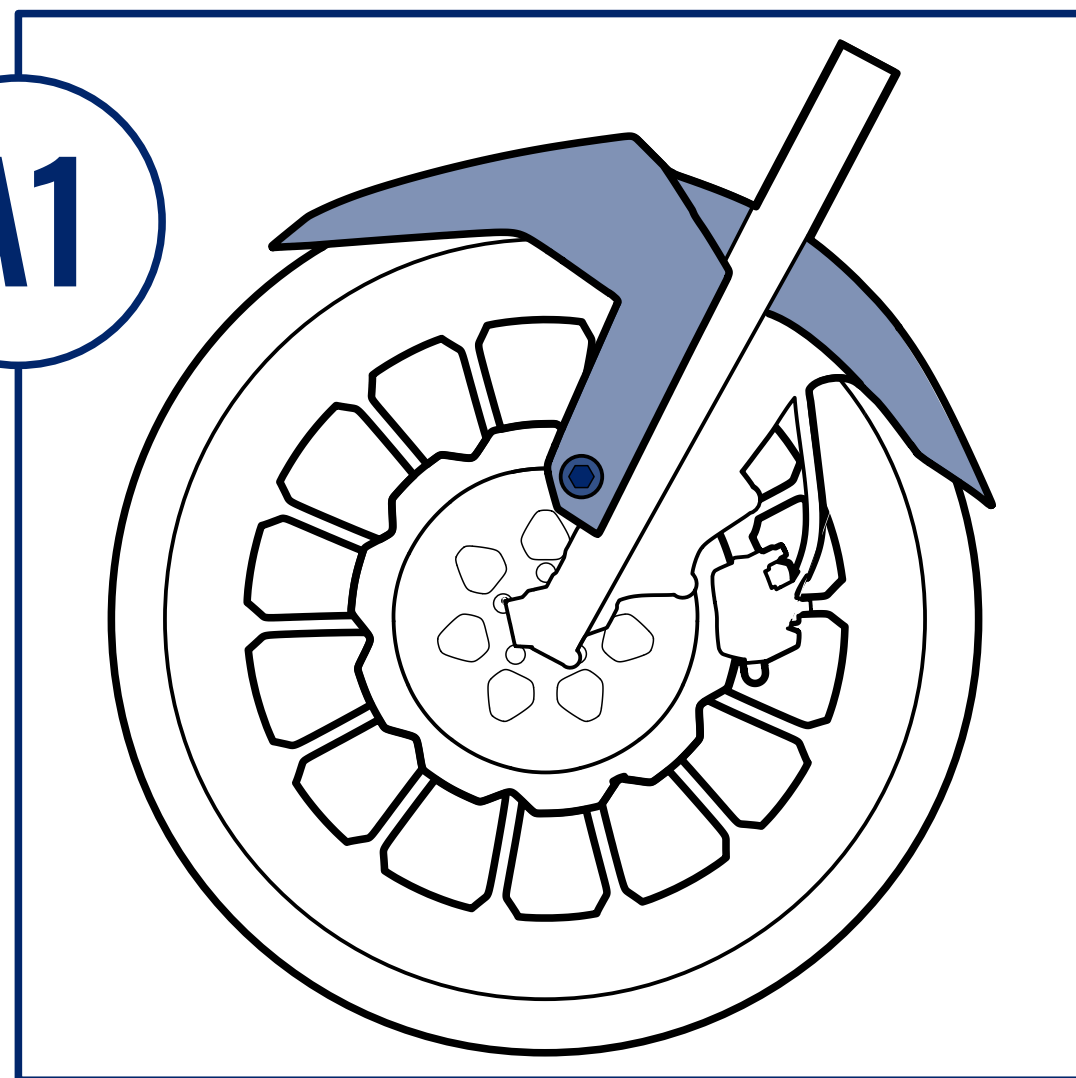

A2

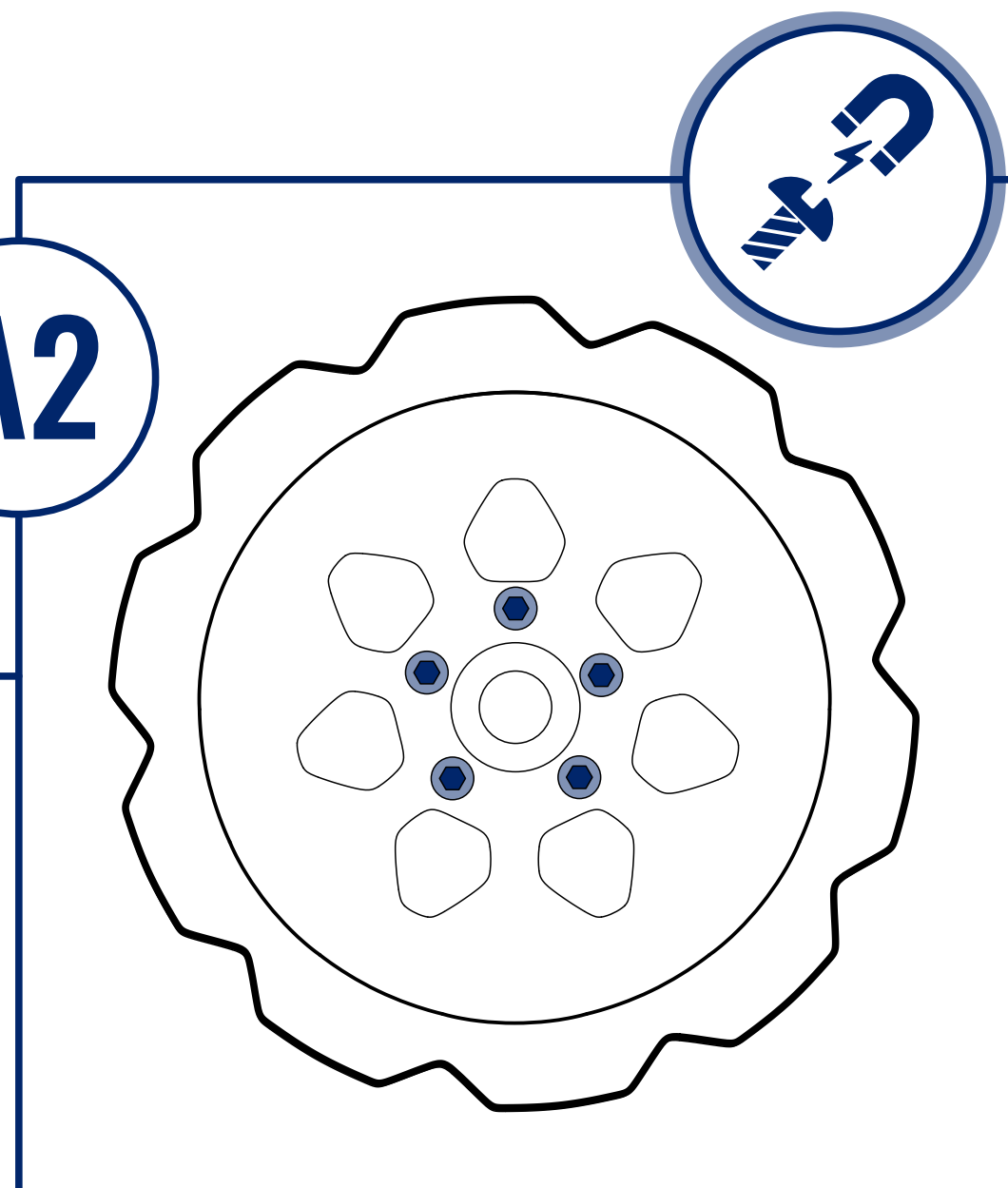

A3

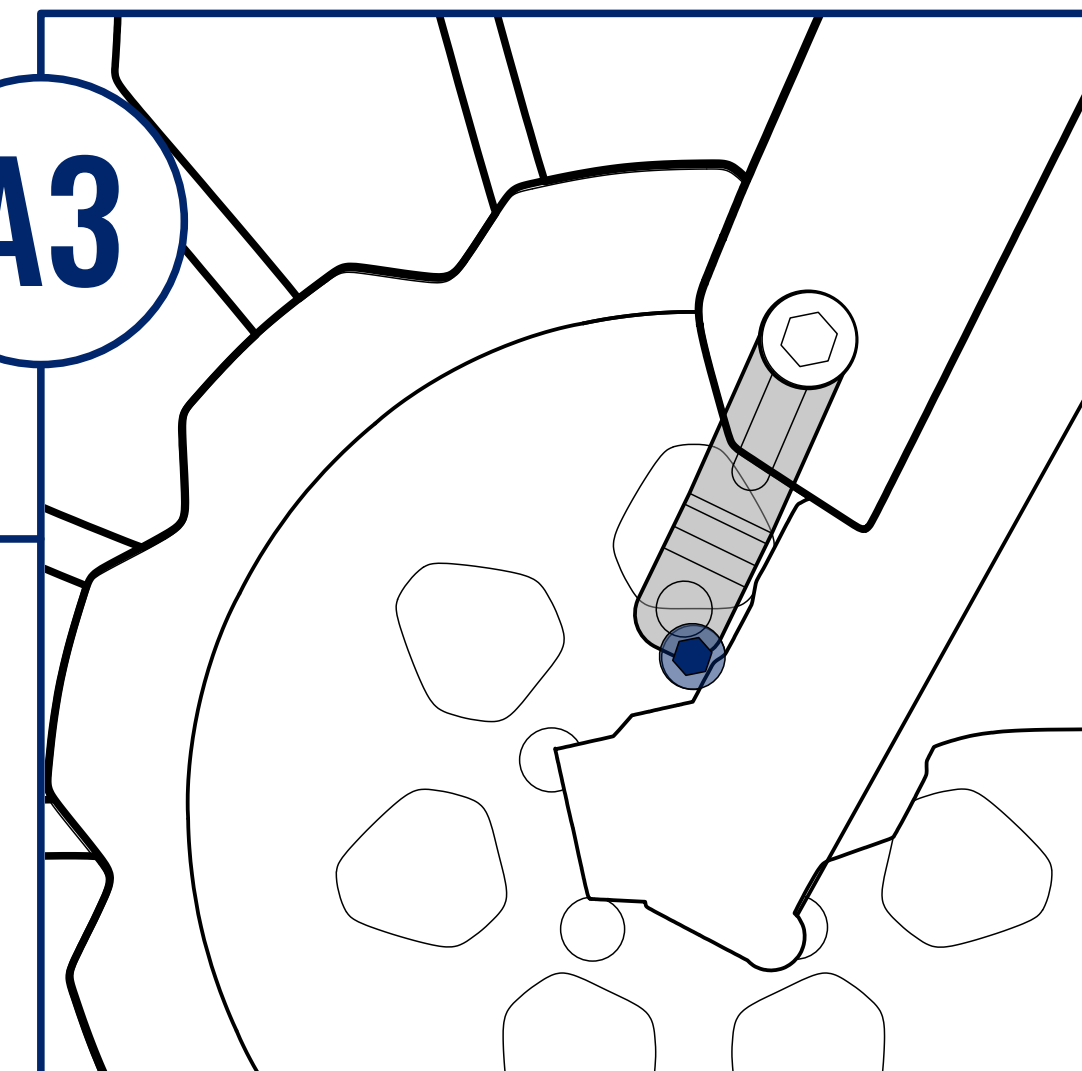

OR

B1

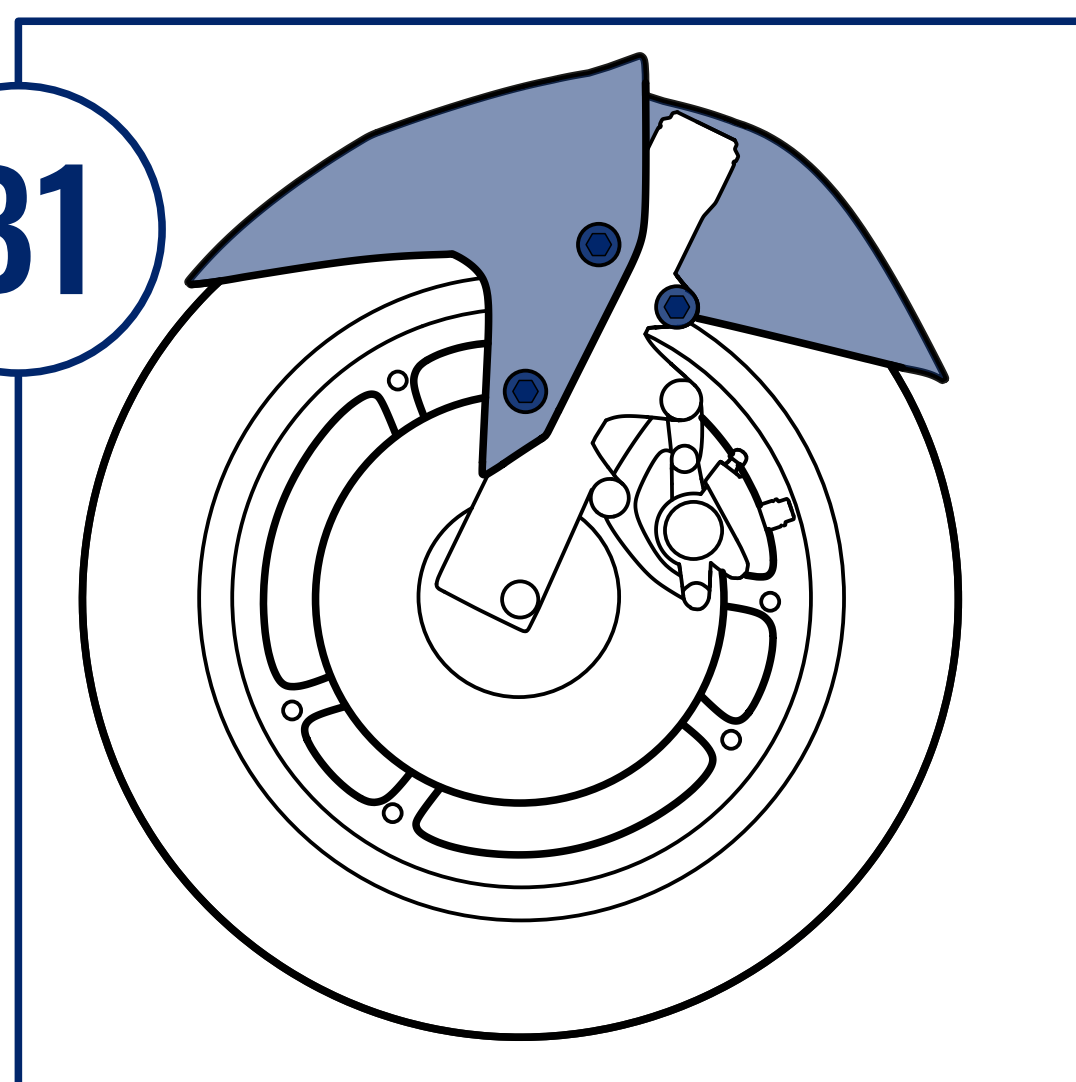

B2

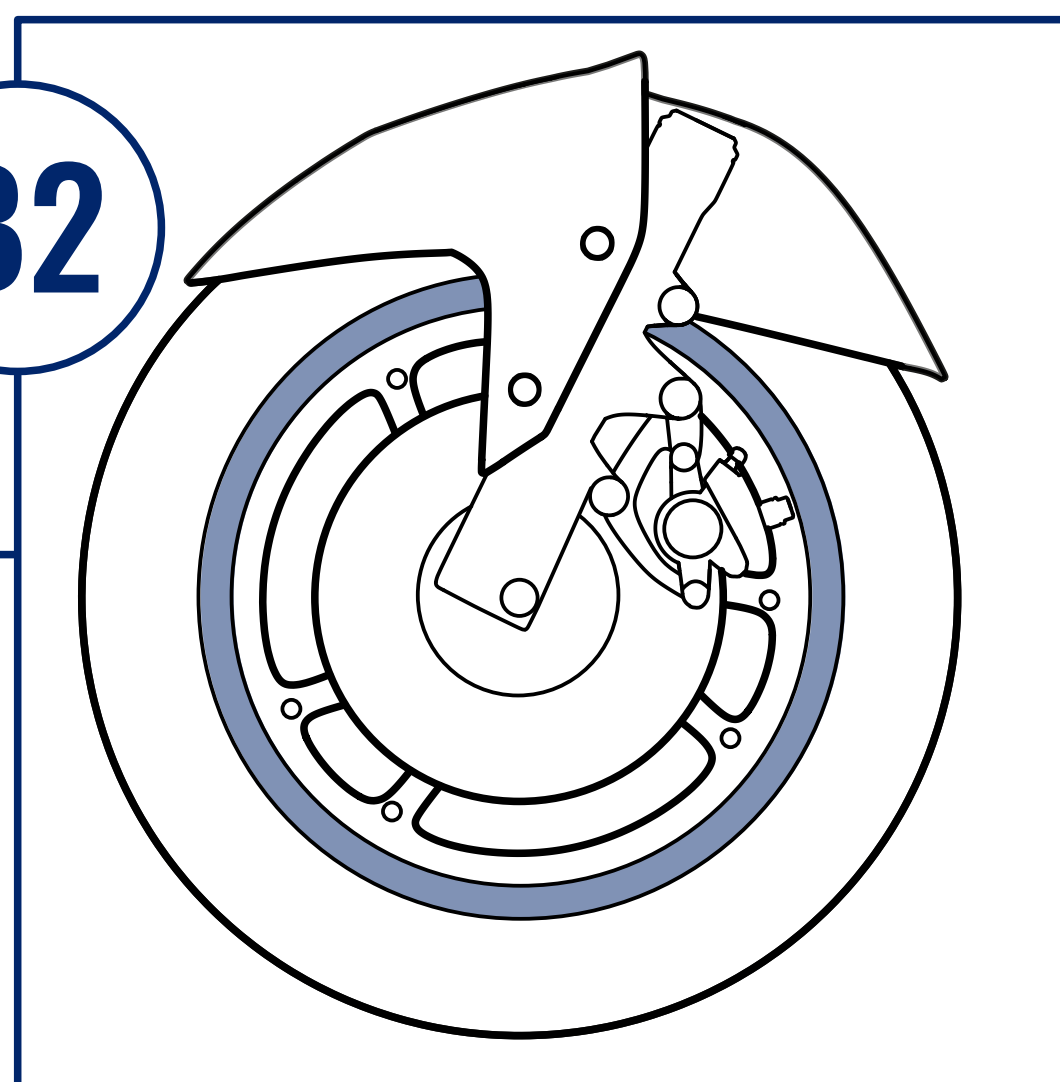

B3

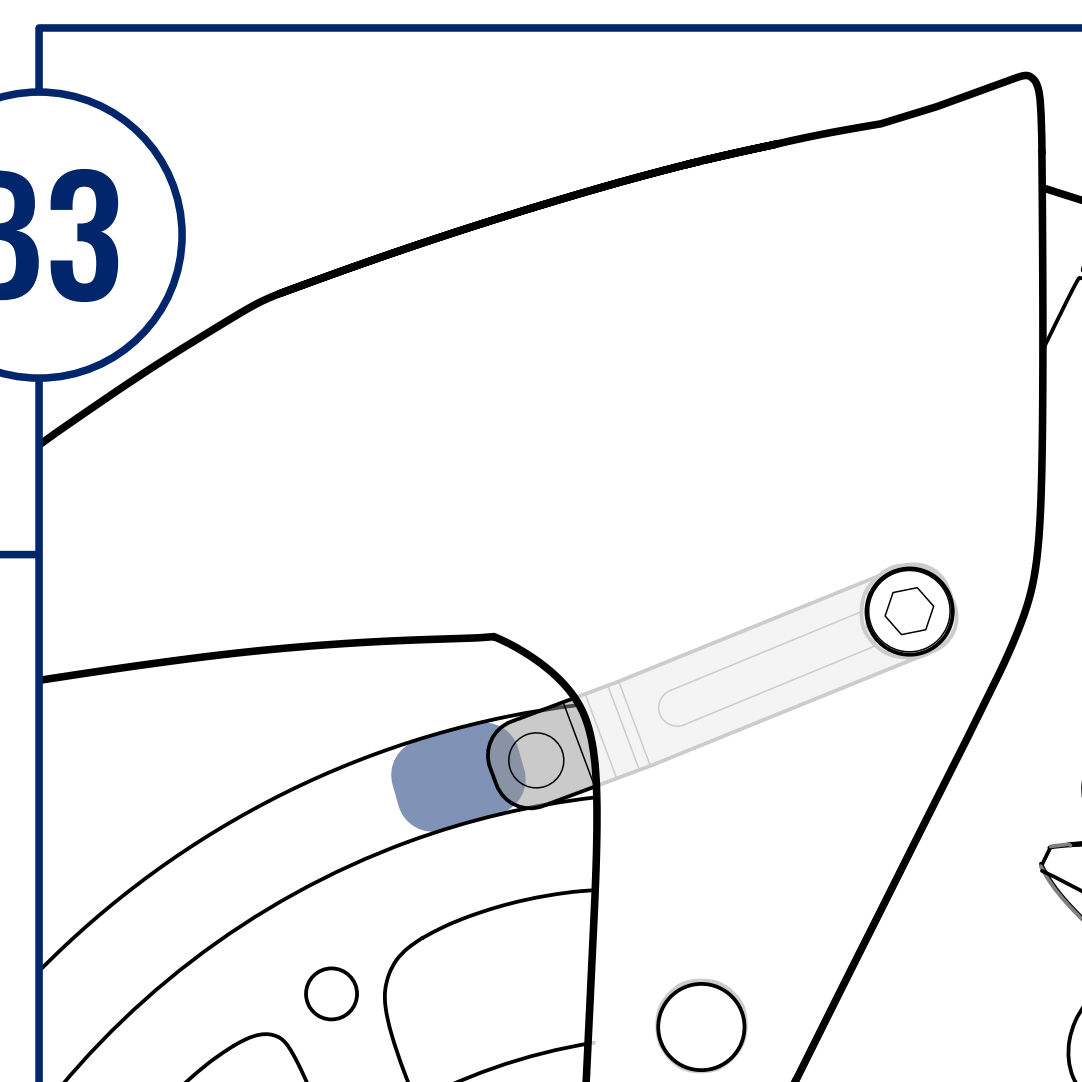

2.A

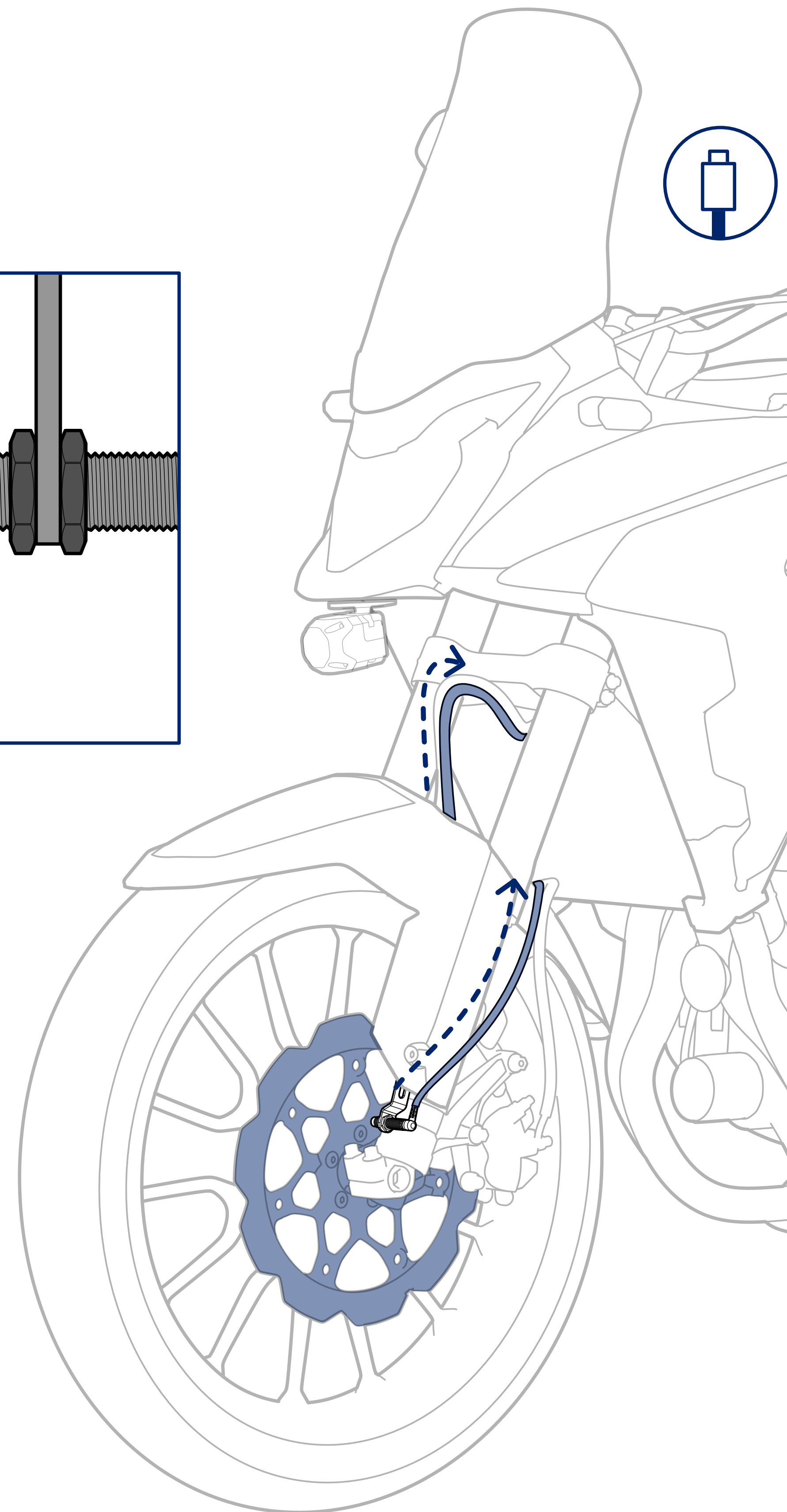
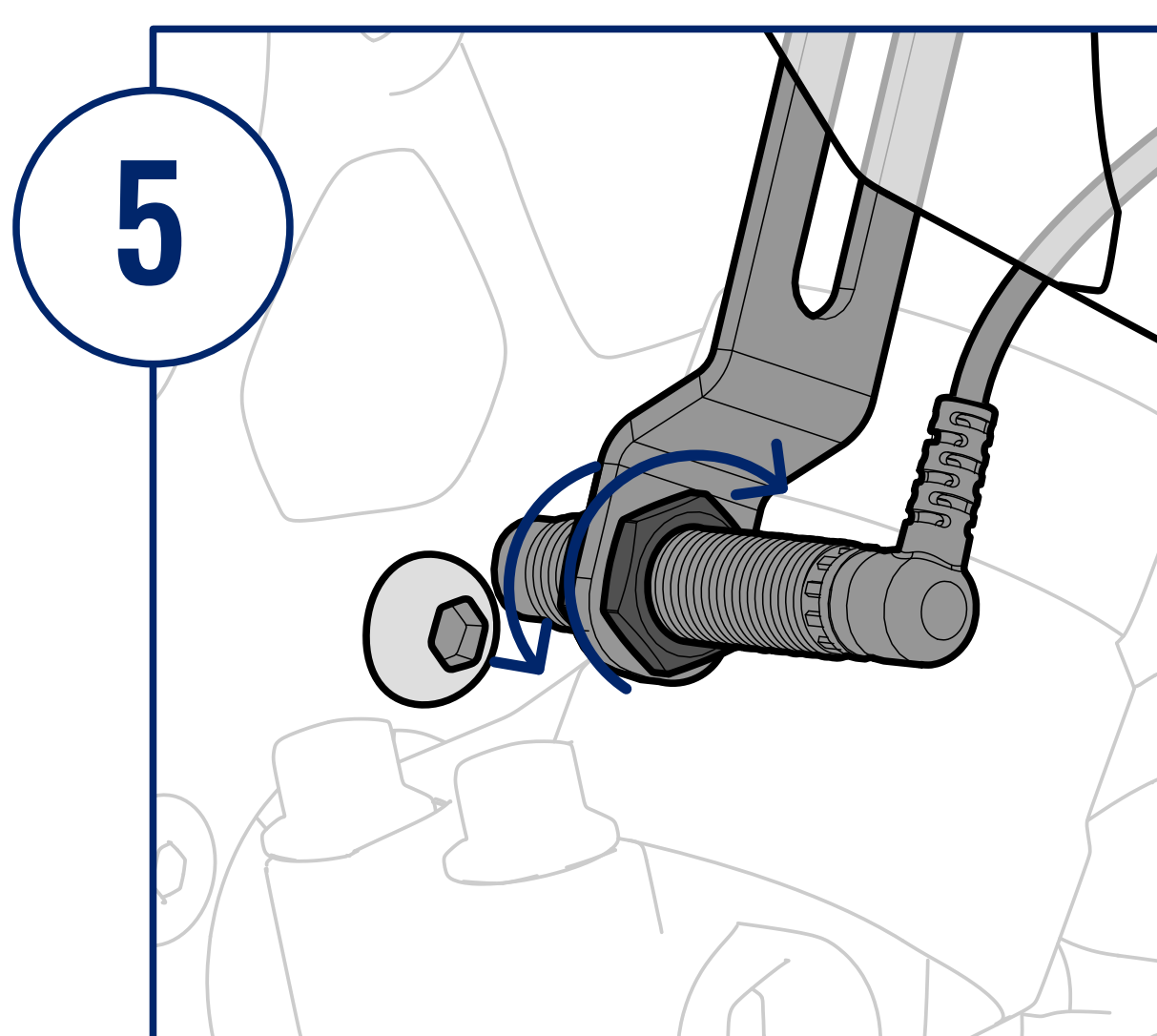
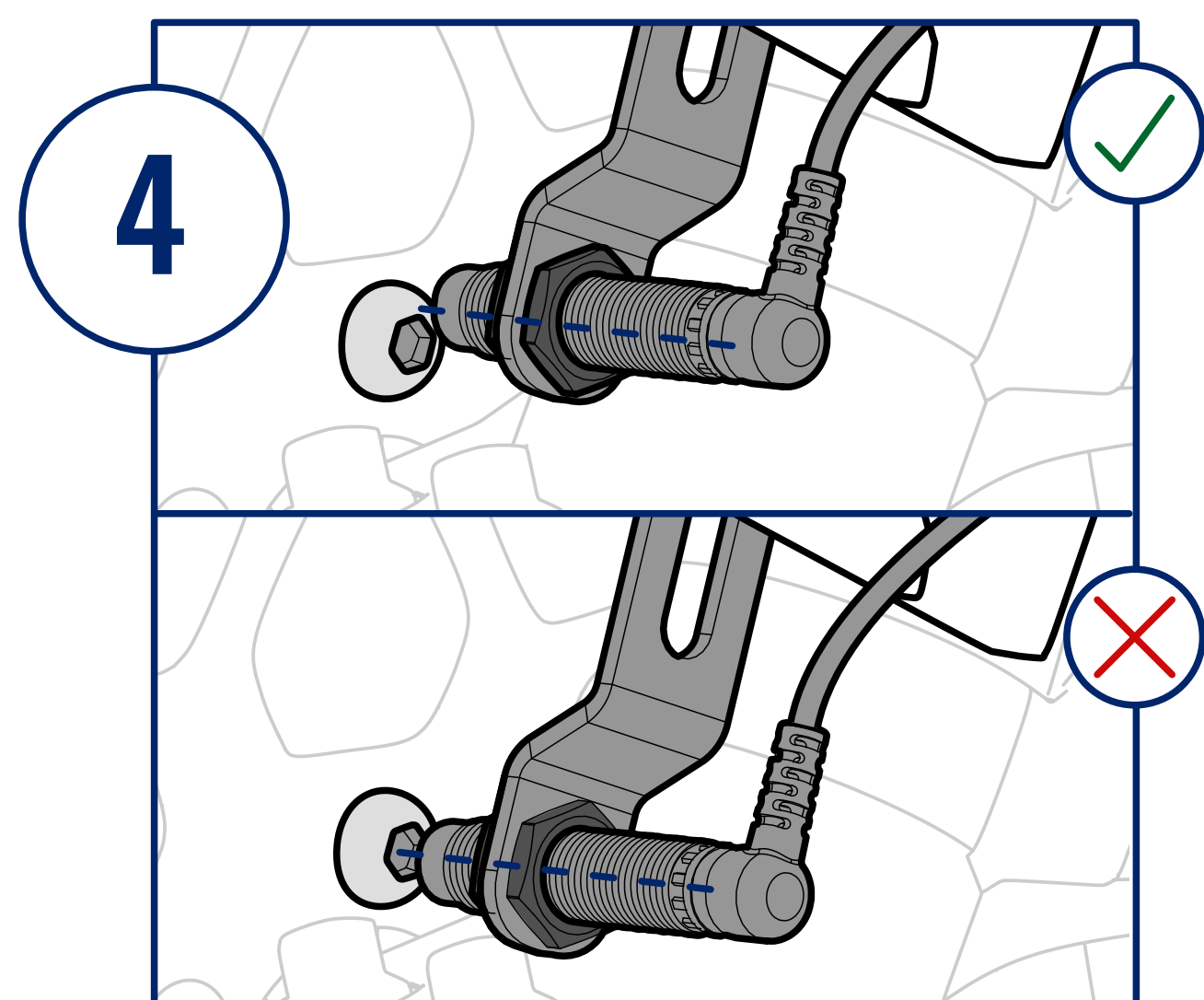
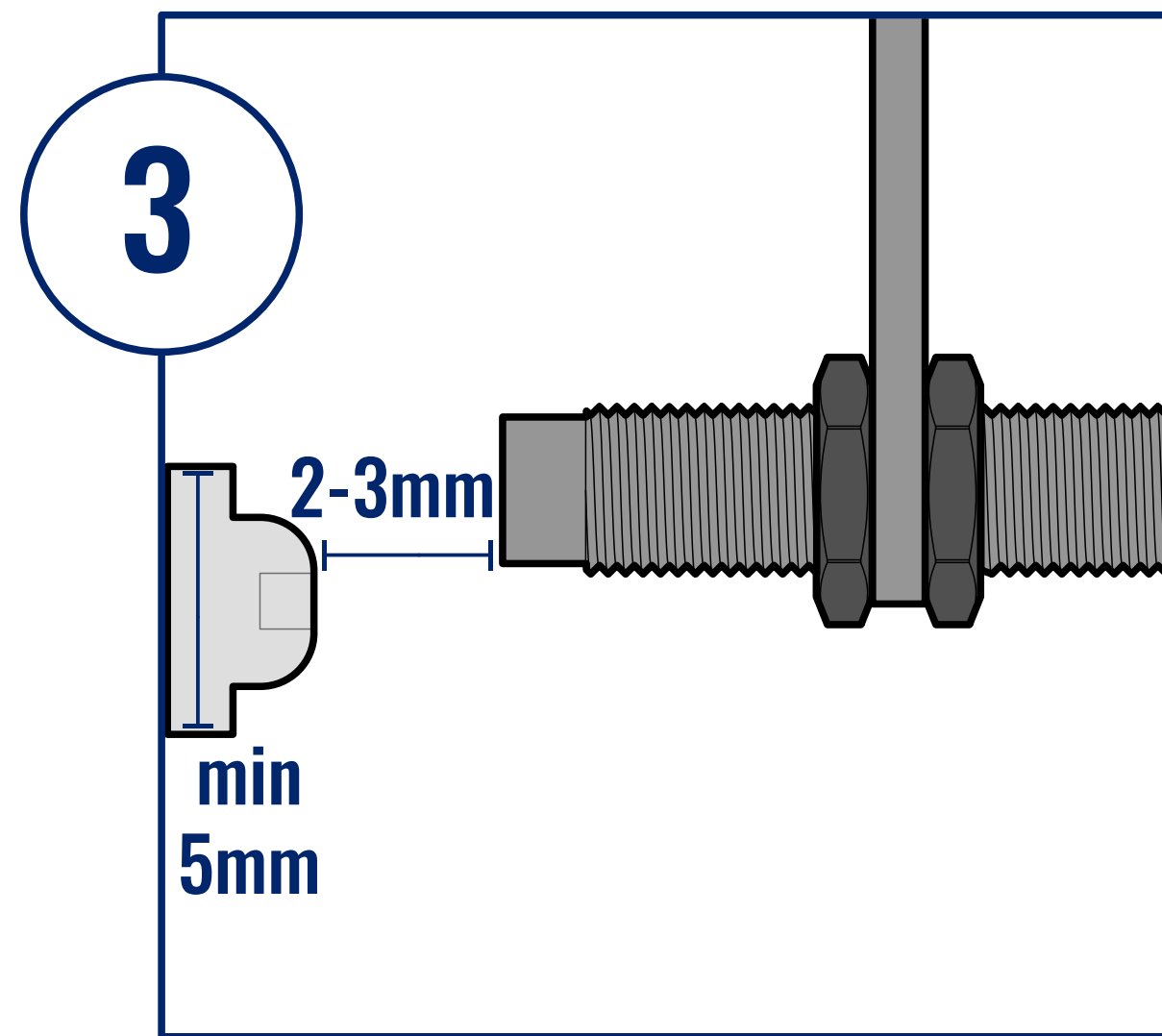
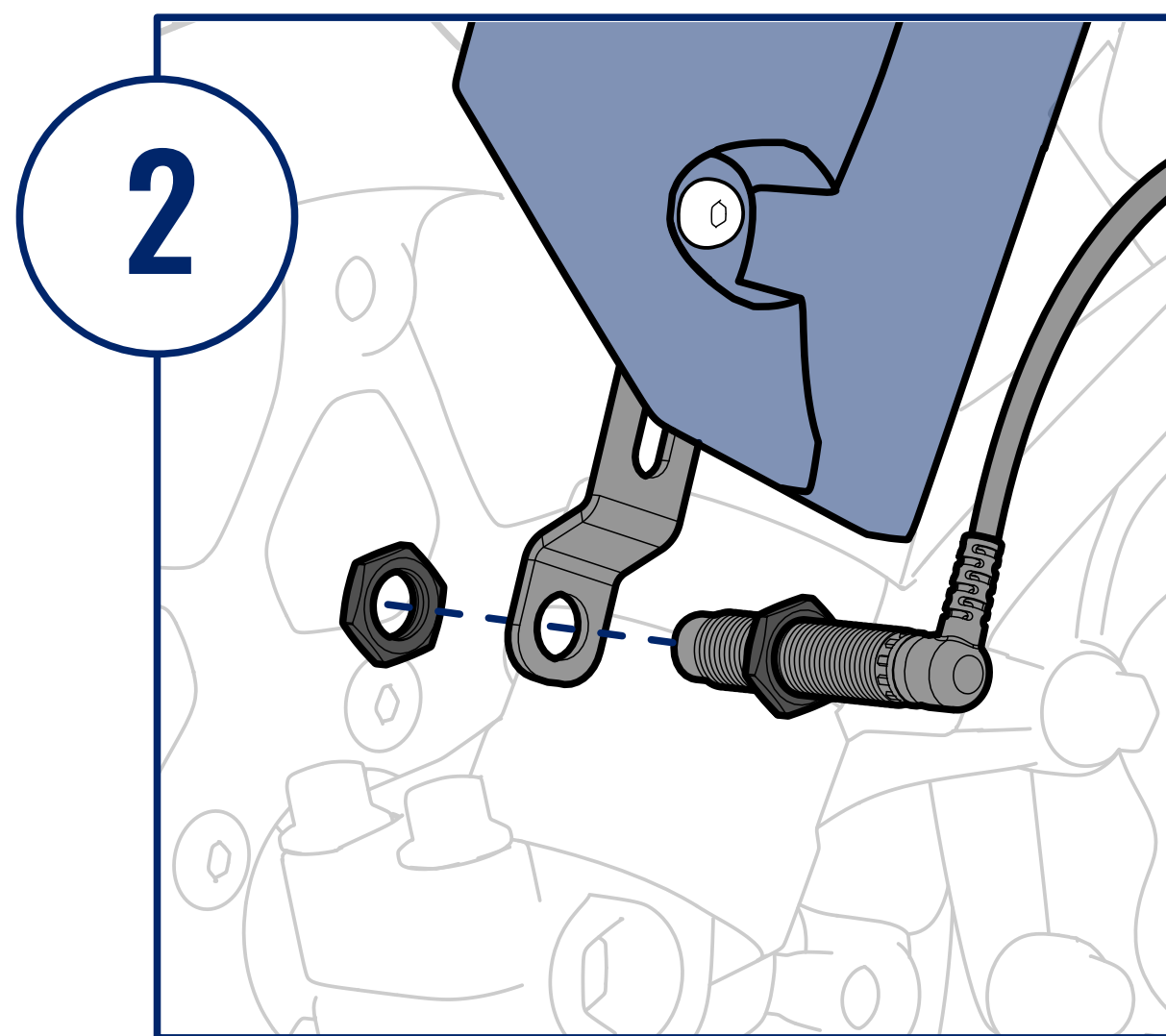
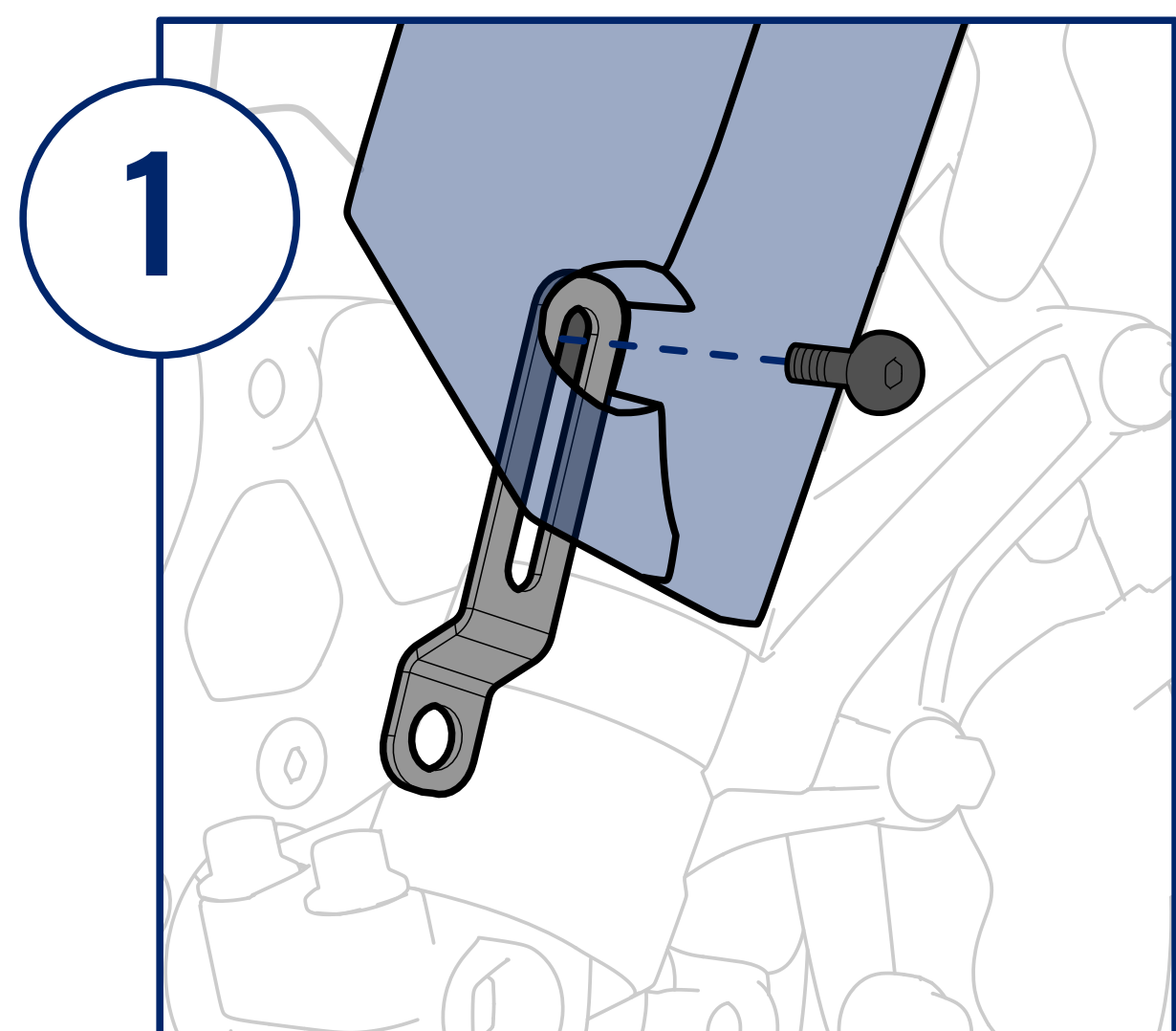
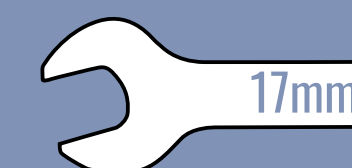
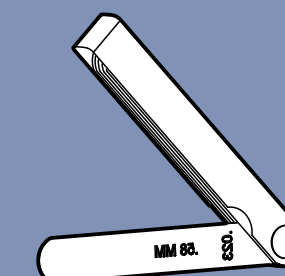
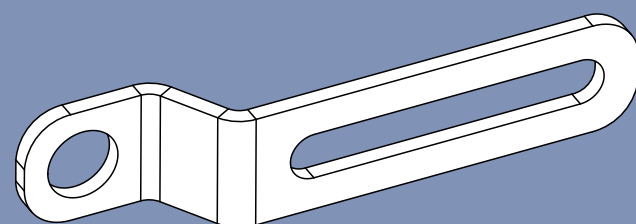
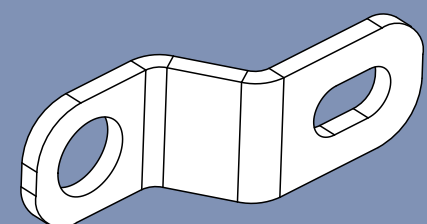
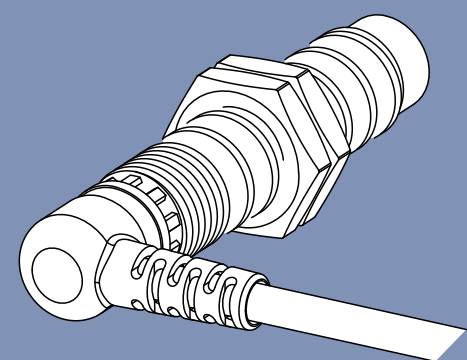

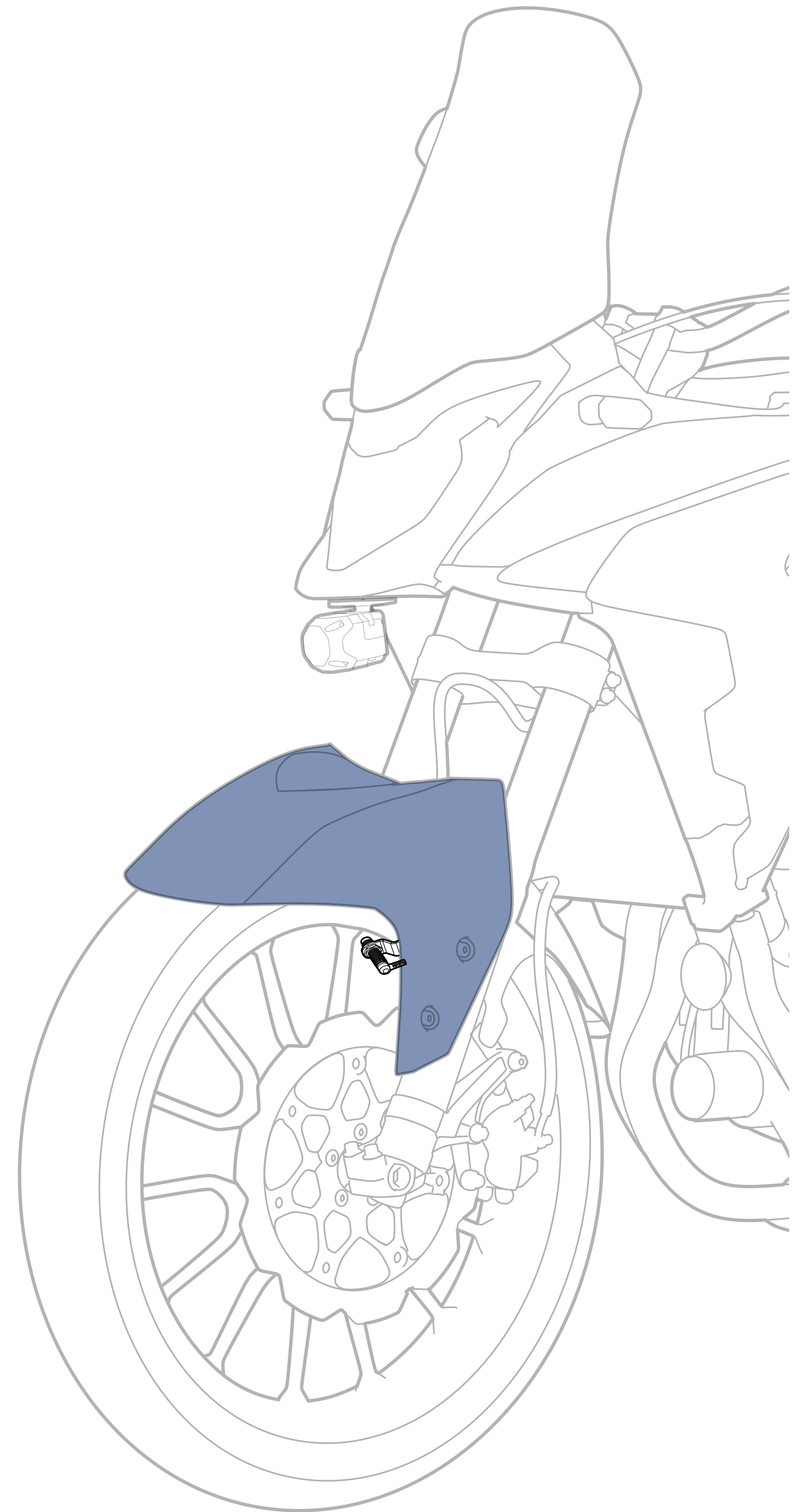
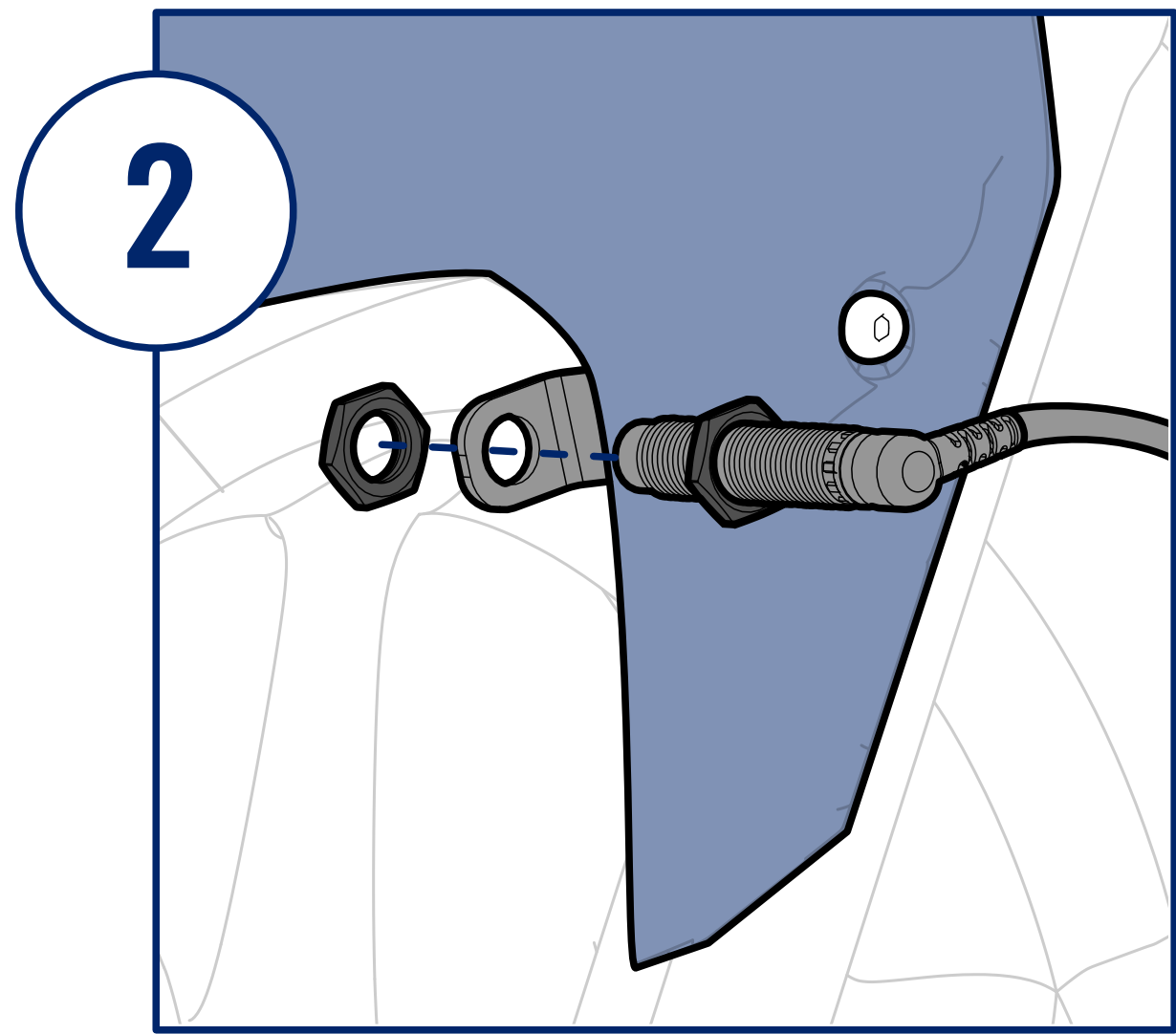
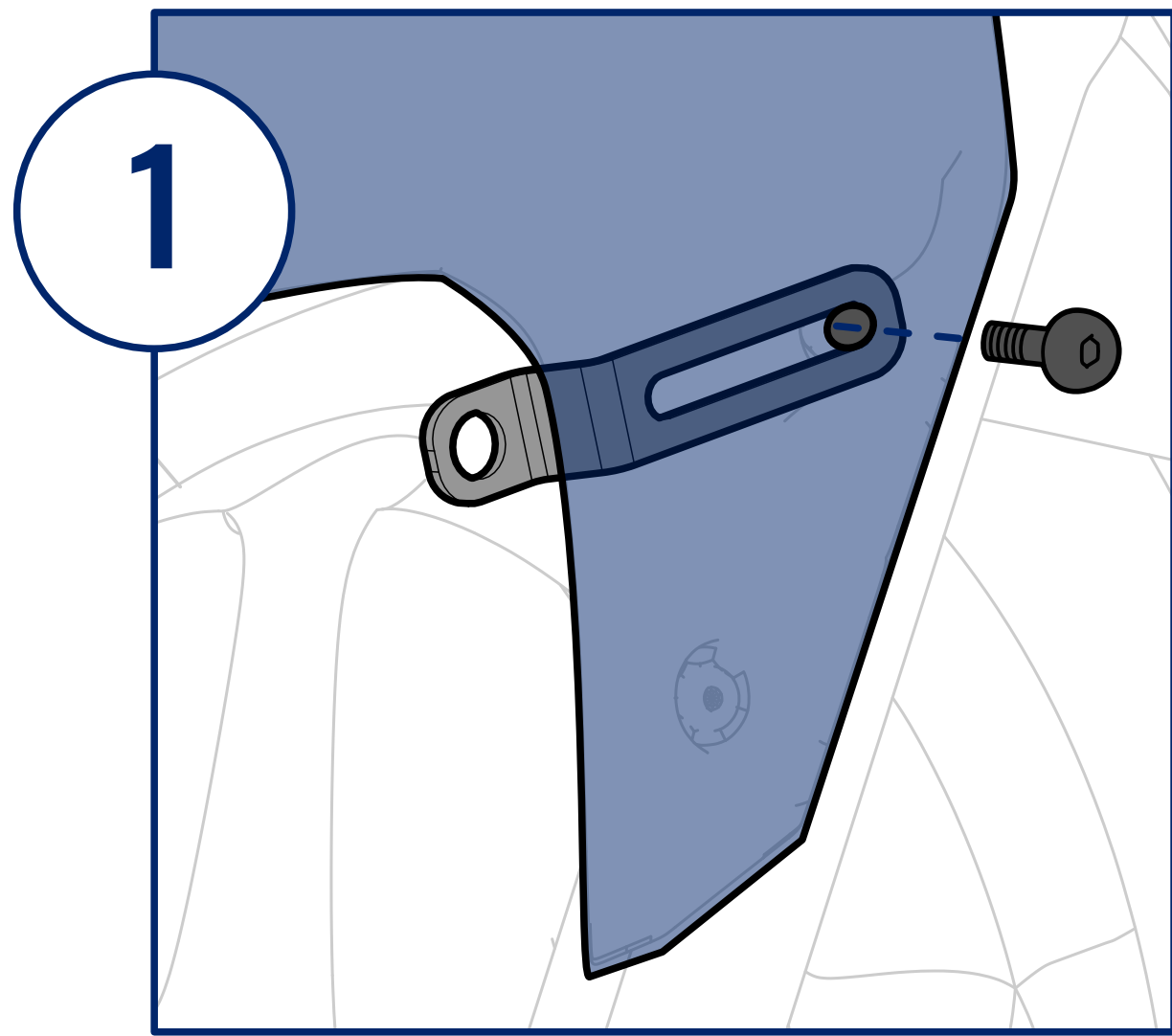
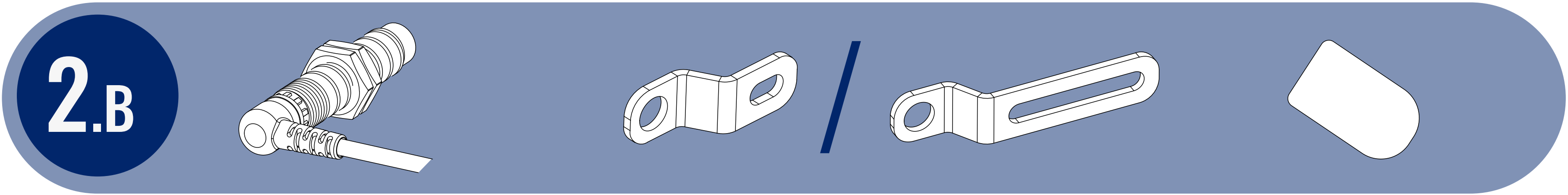

2.B

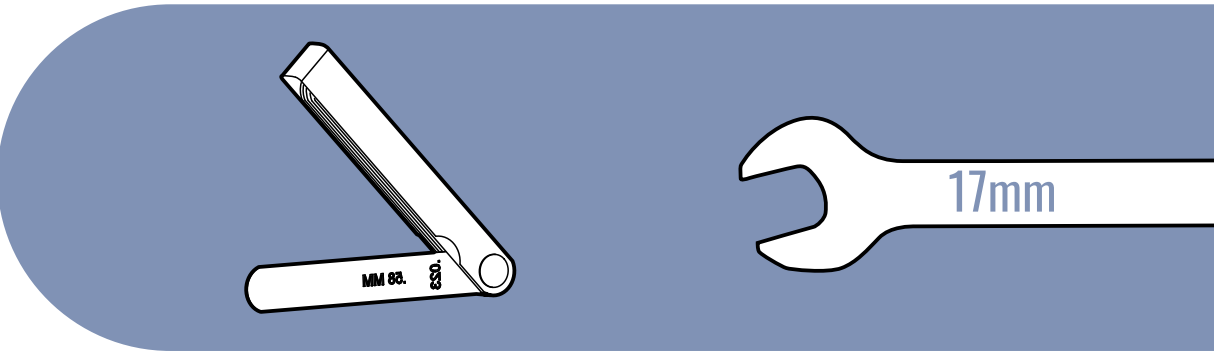
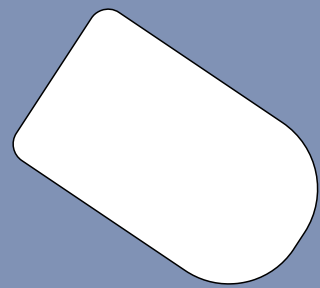

Bend to shape



3

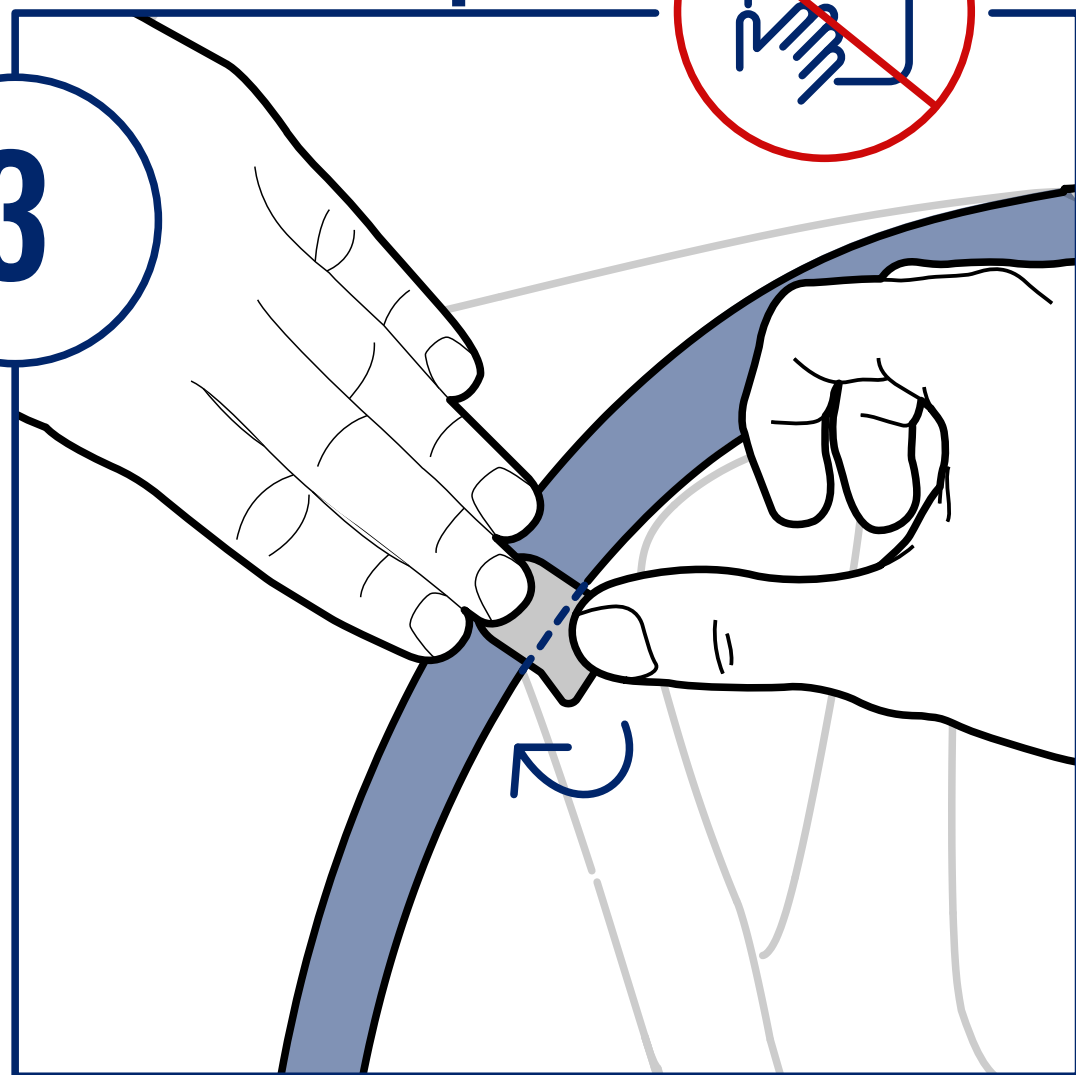

4

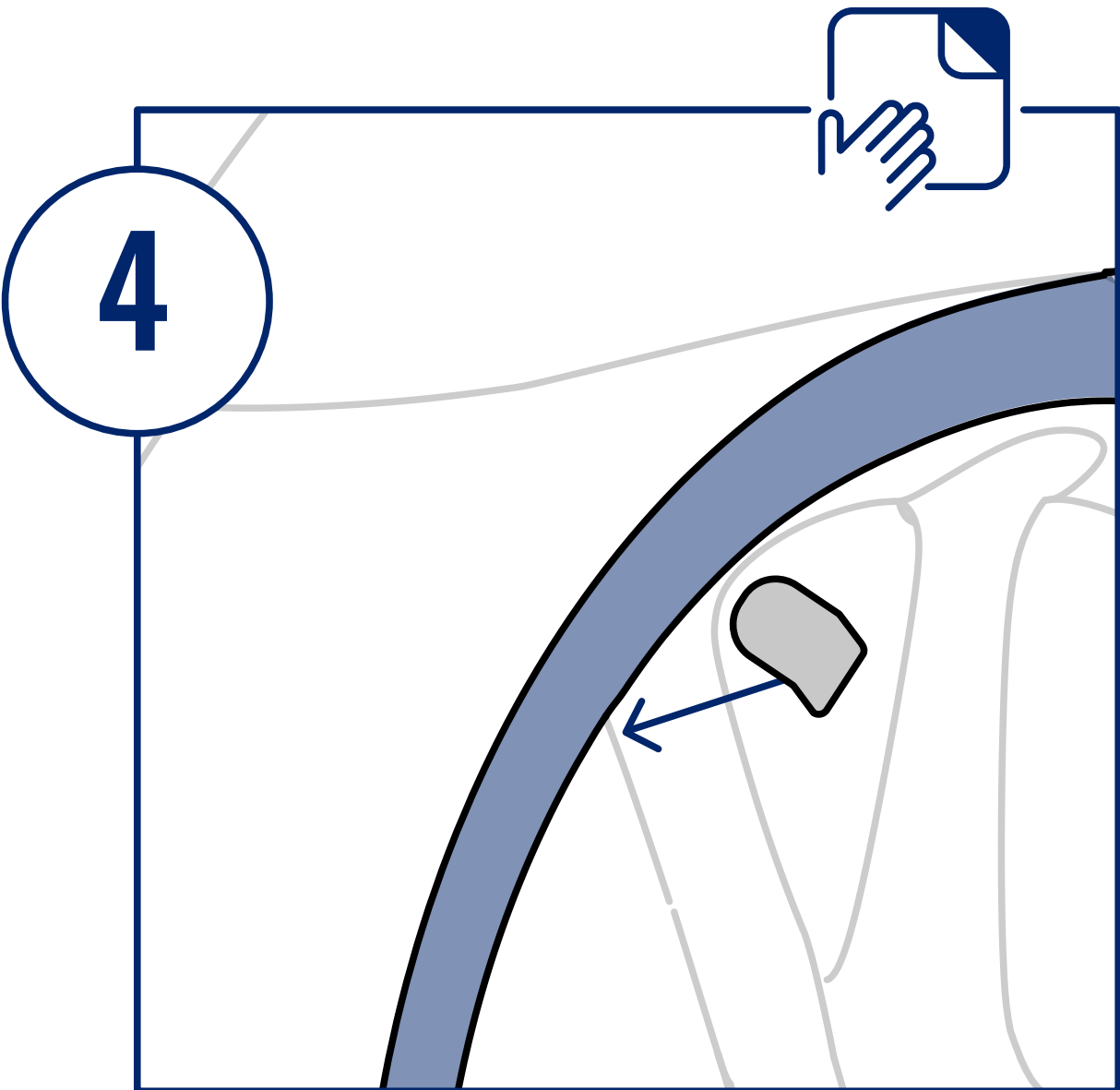

5

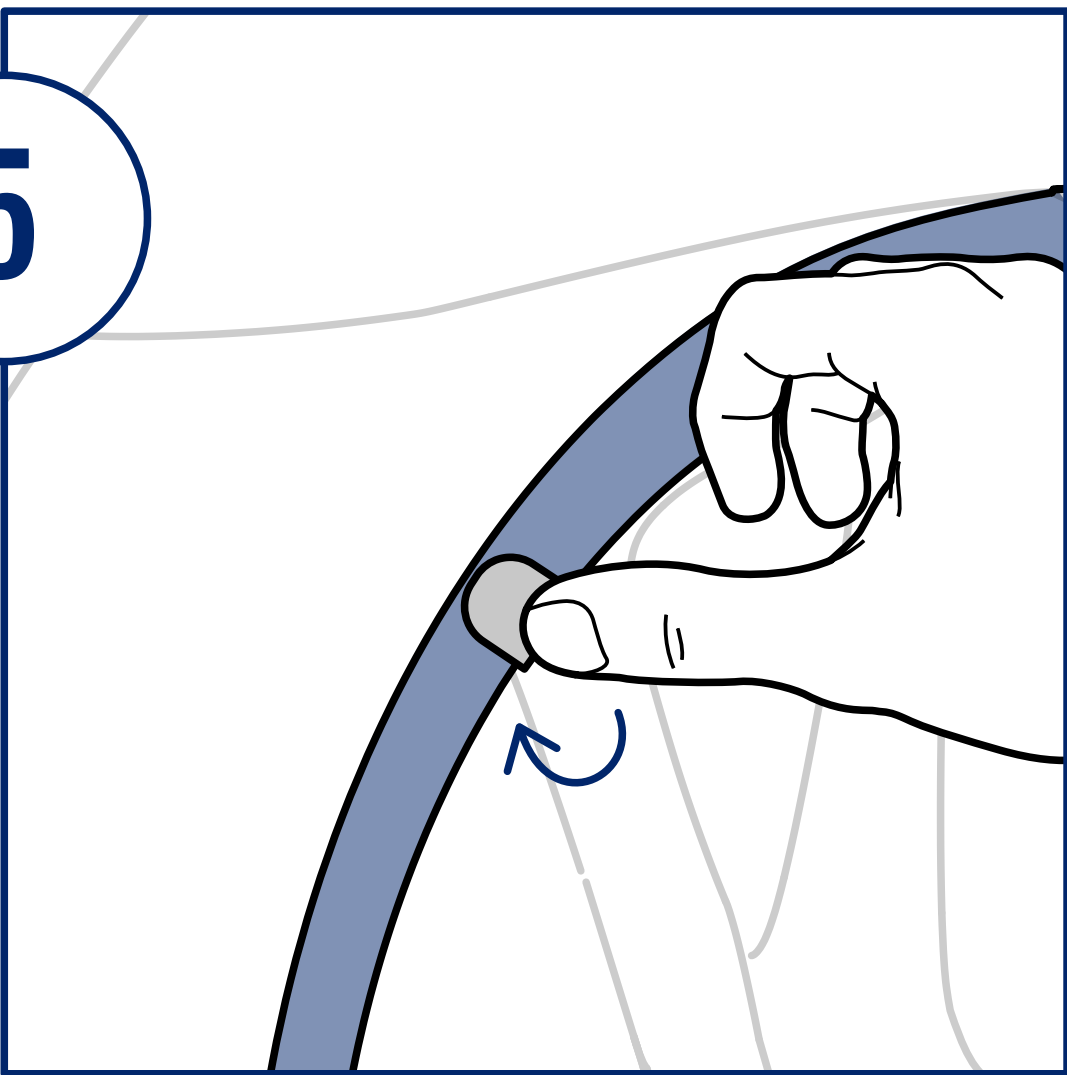

6

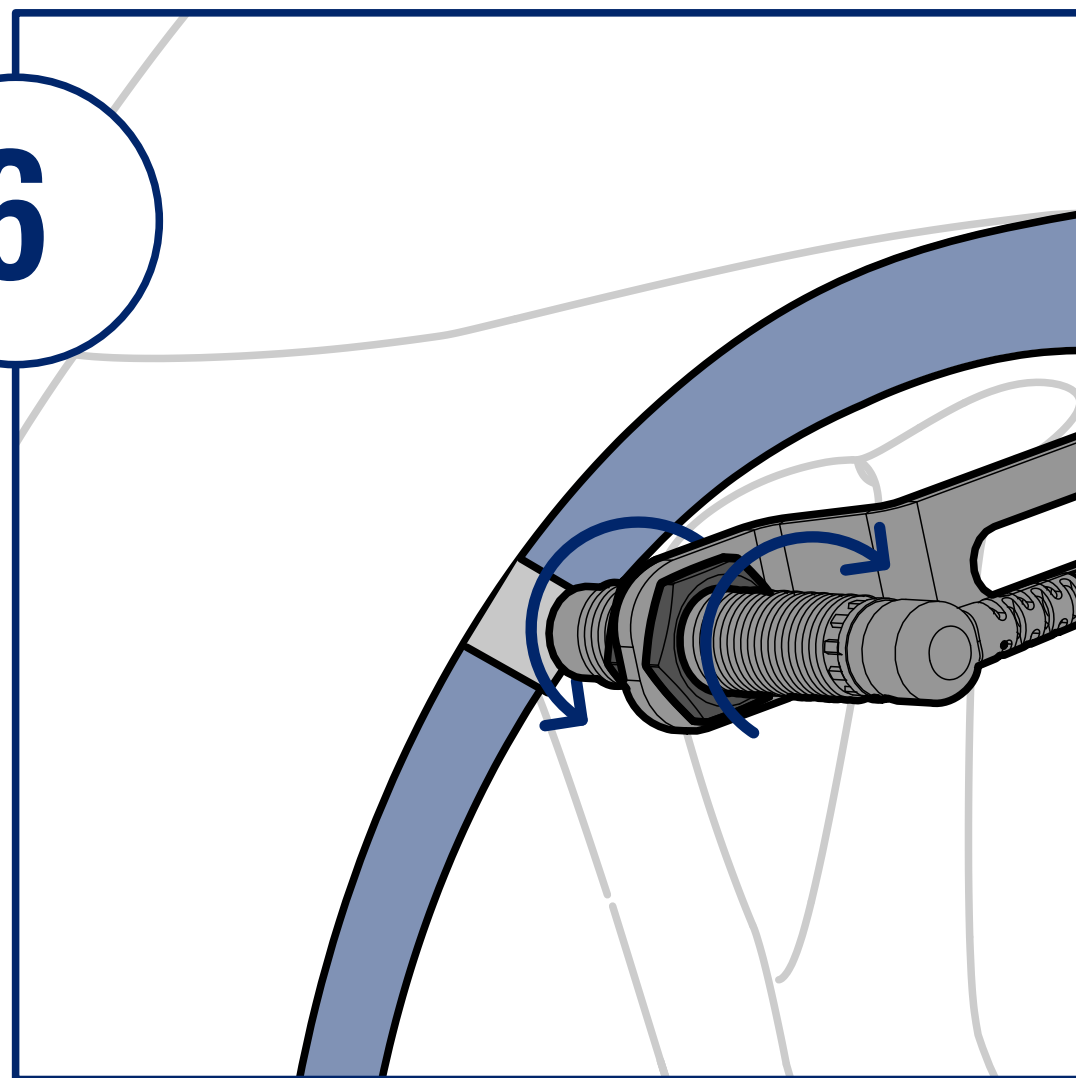

7

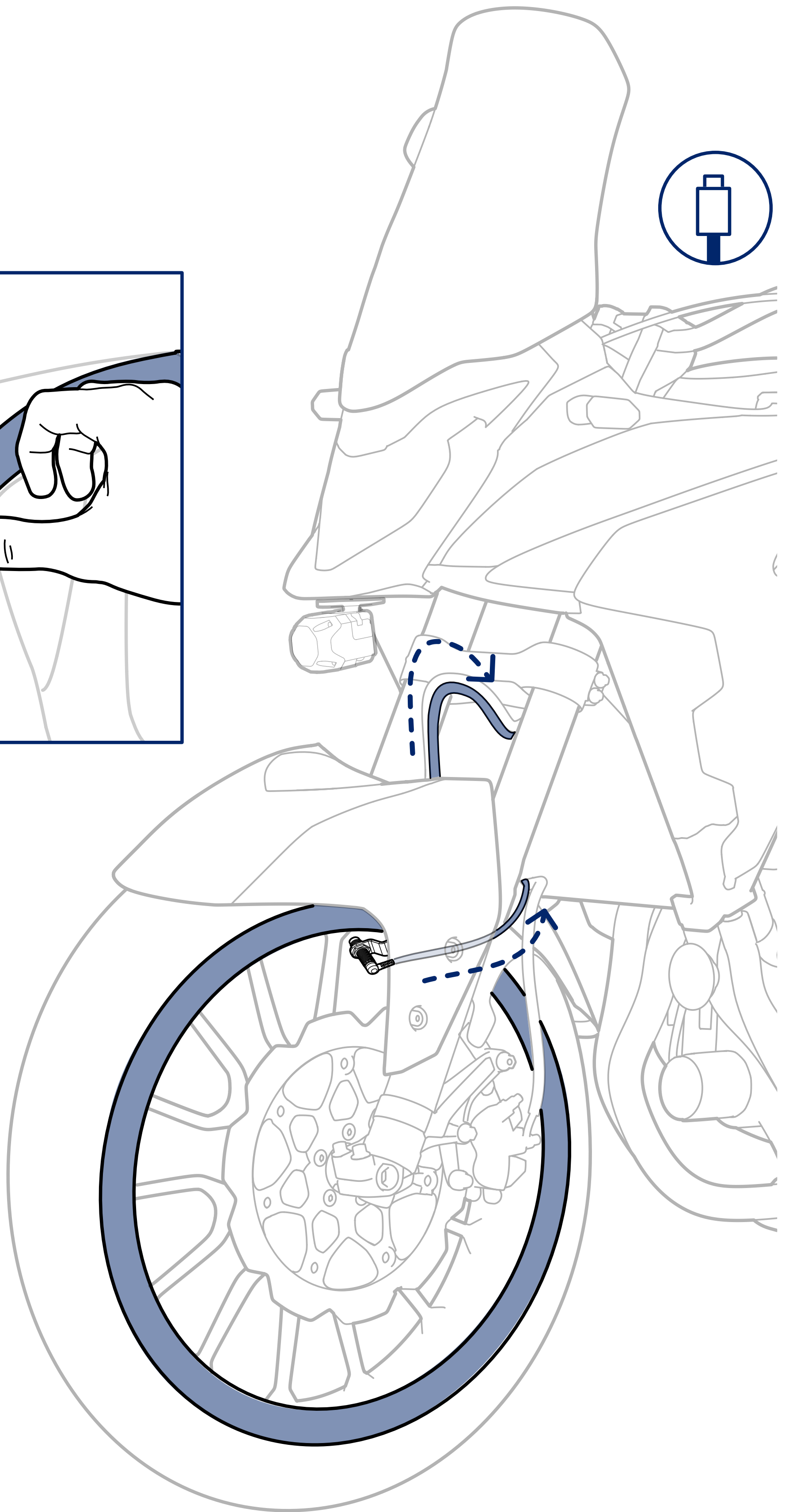
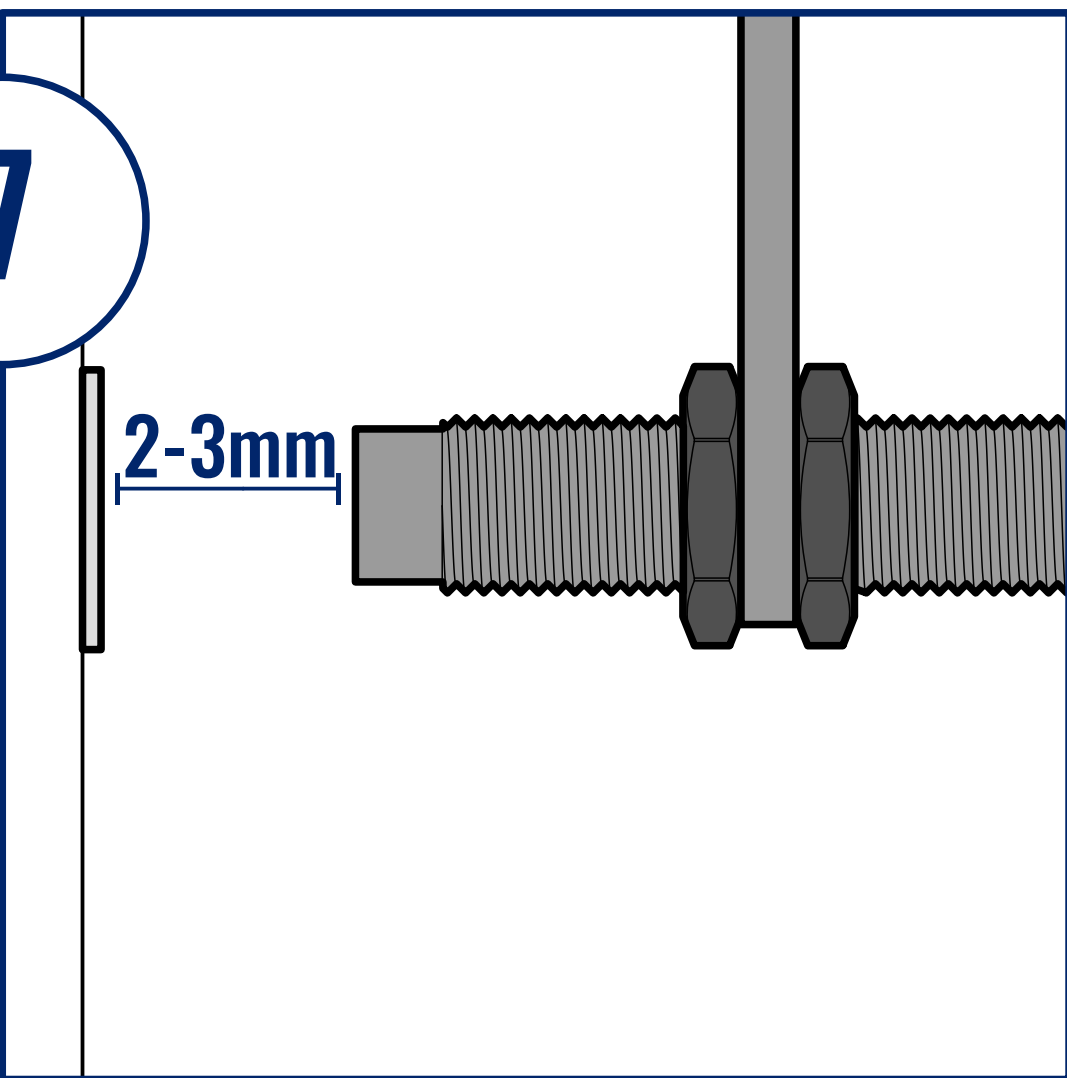

3

i

Find location

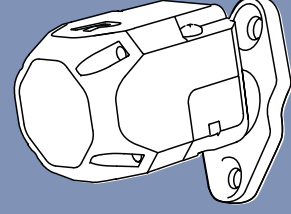

<5cm <5cm

min 70cm

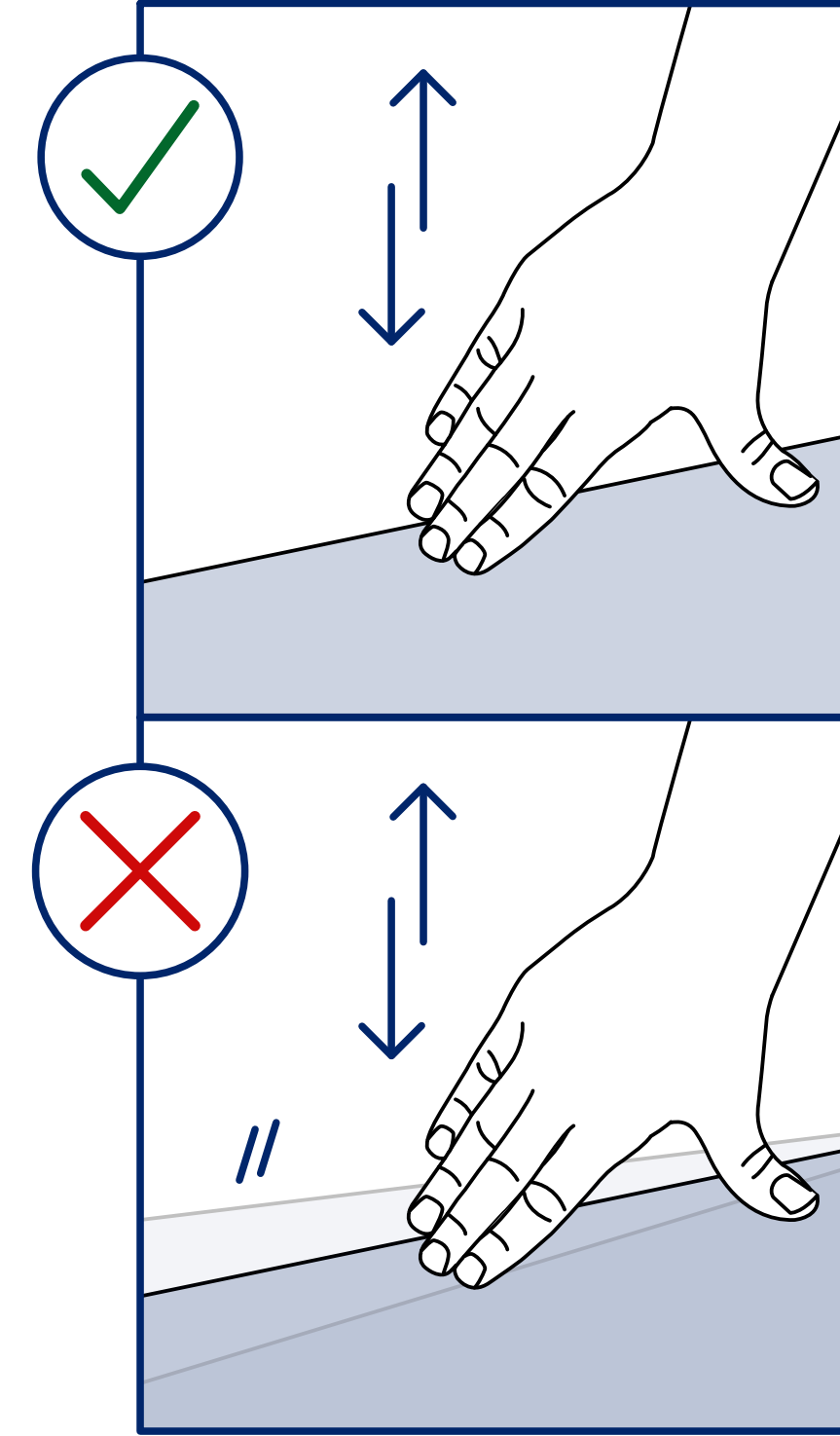
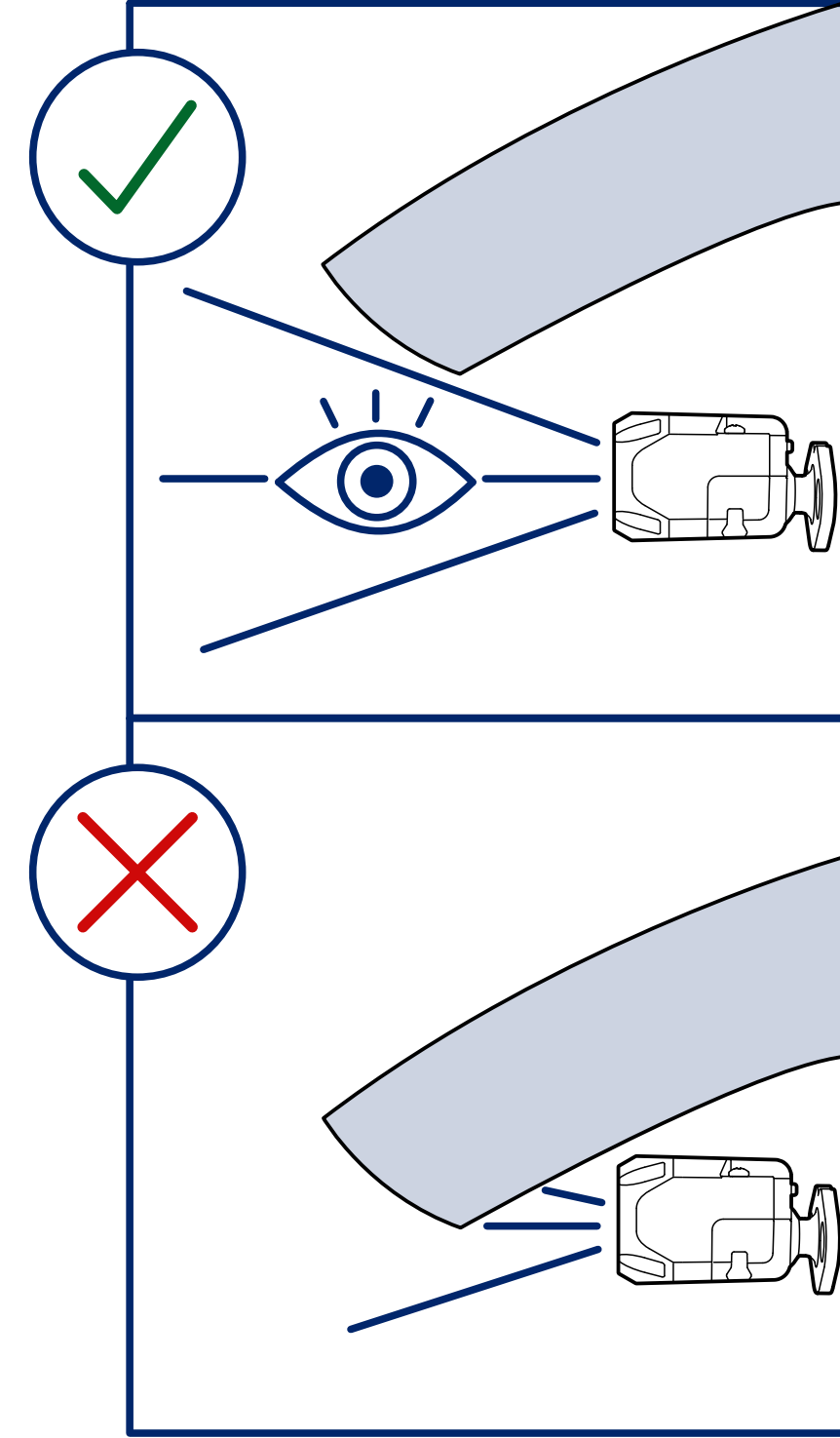
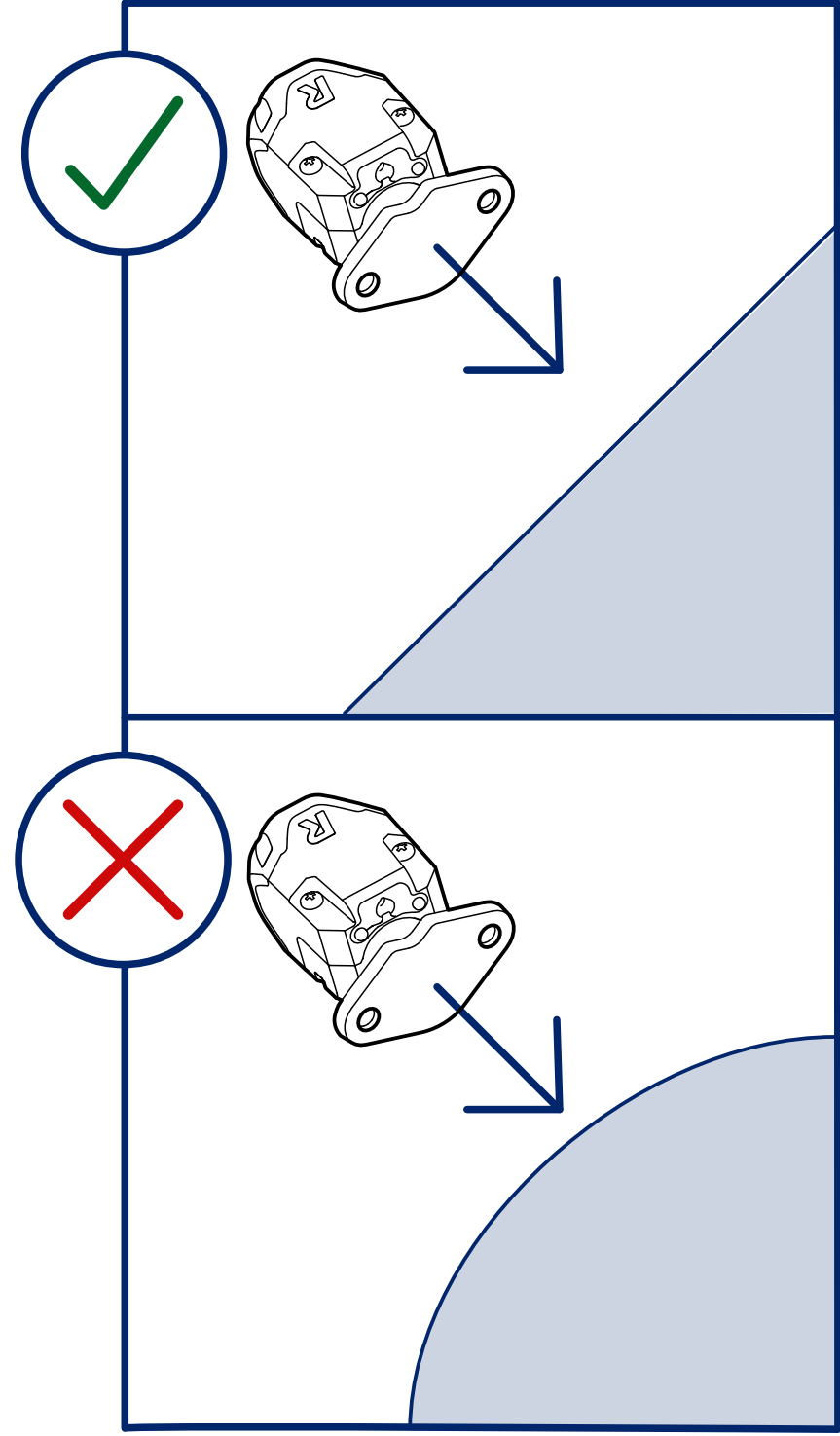
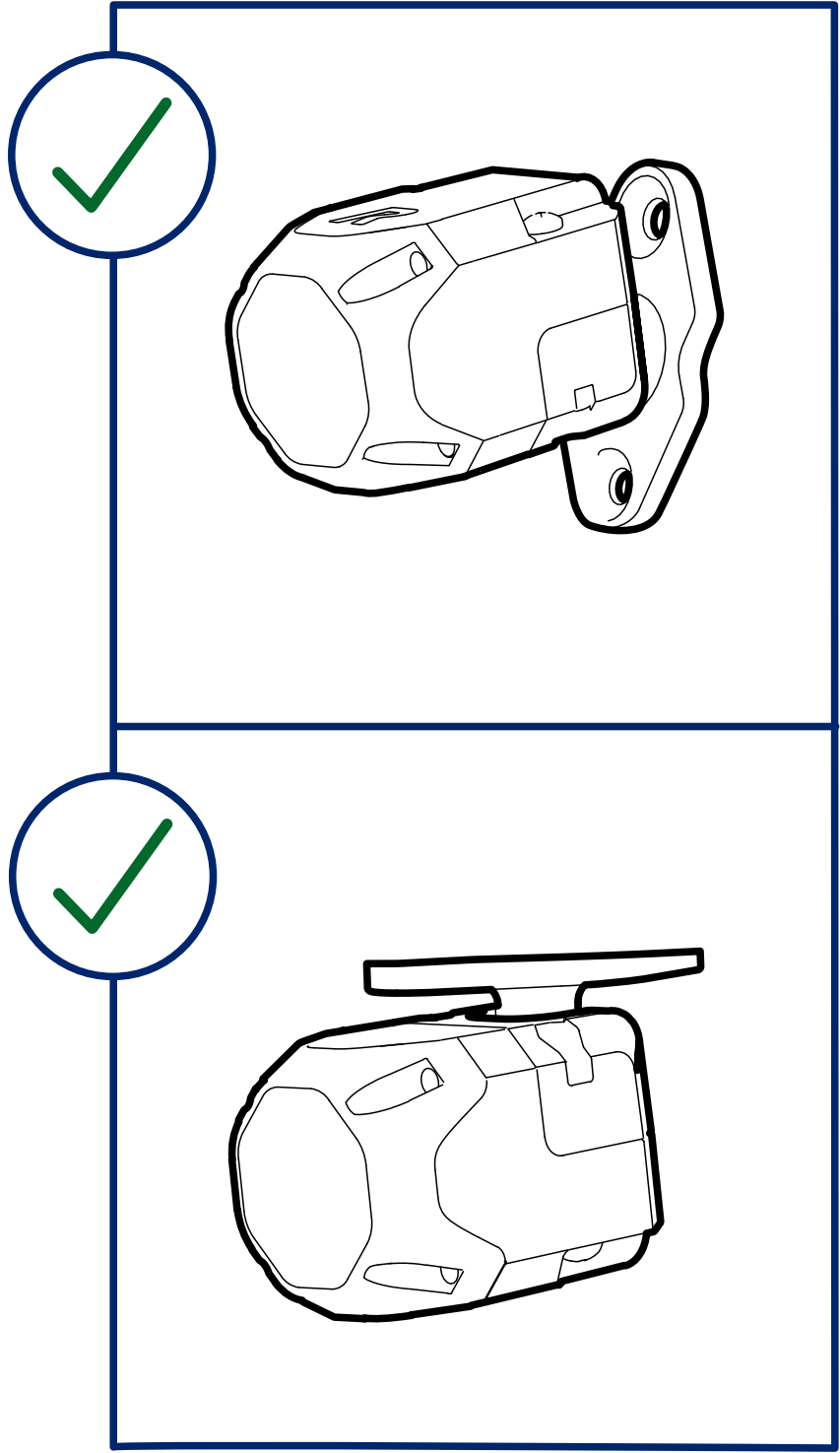
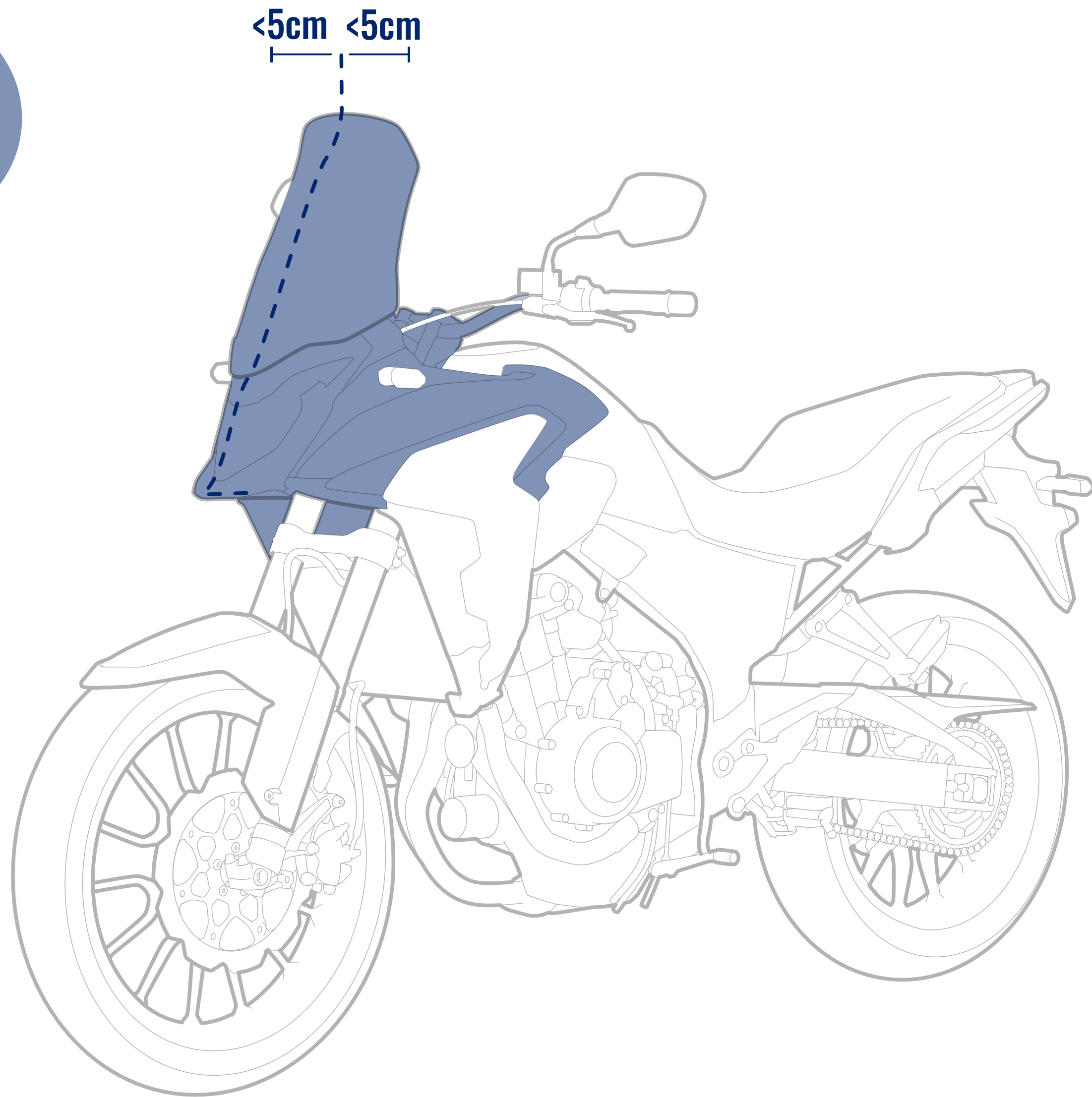

3

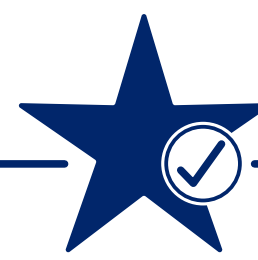
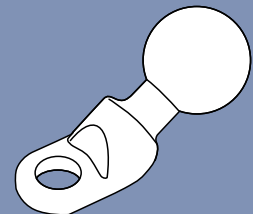
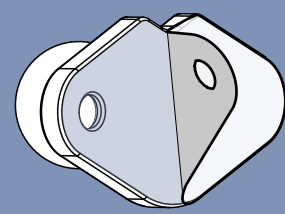
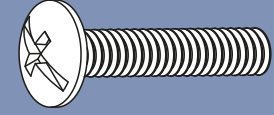
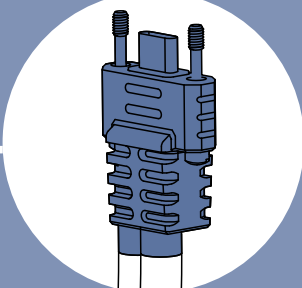
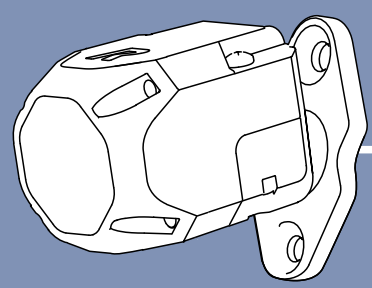

Preferred

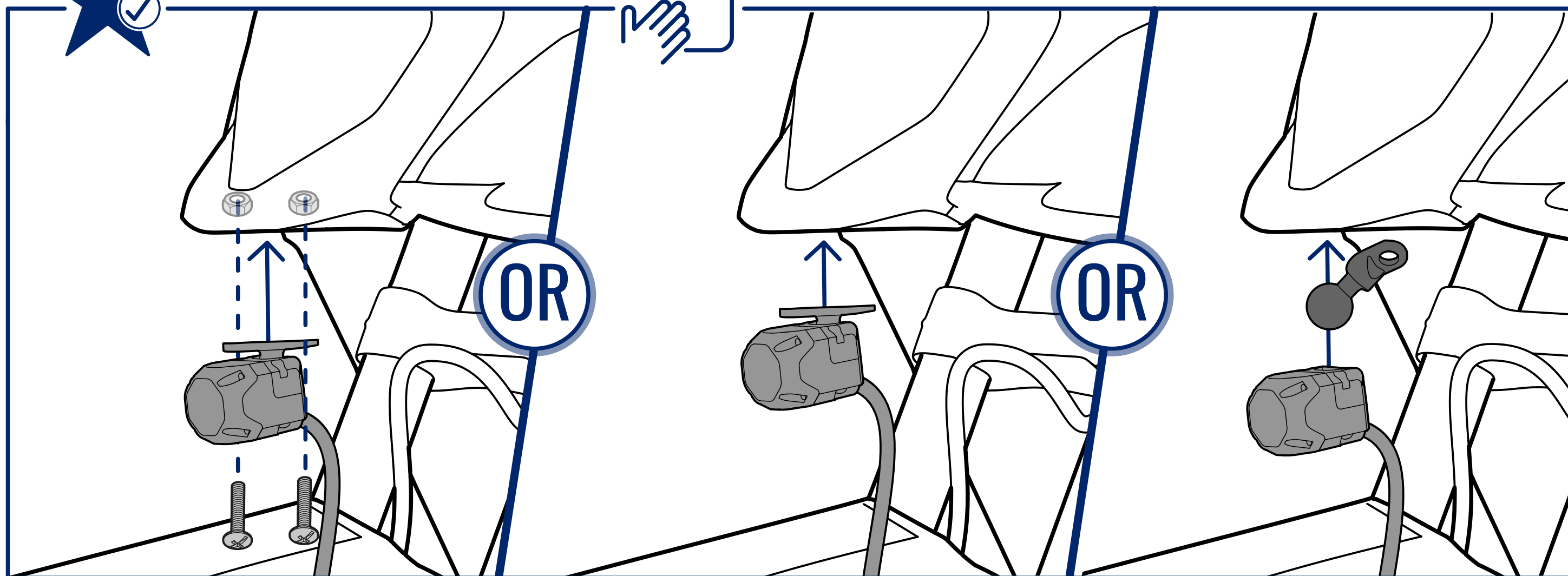

1

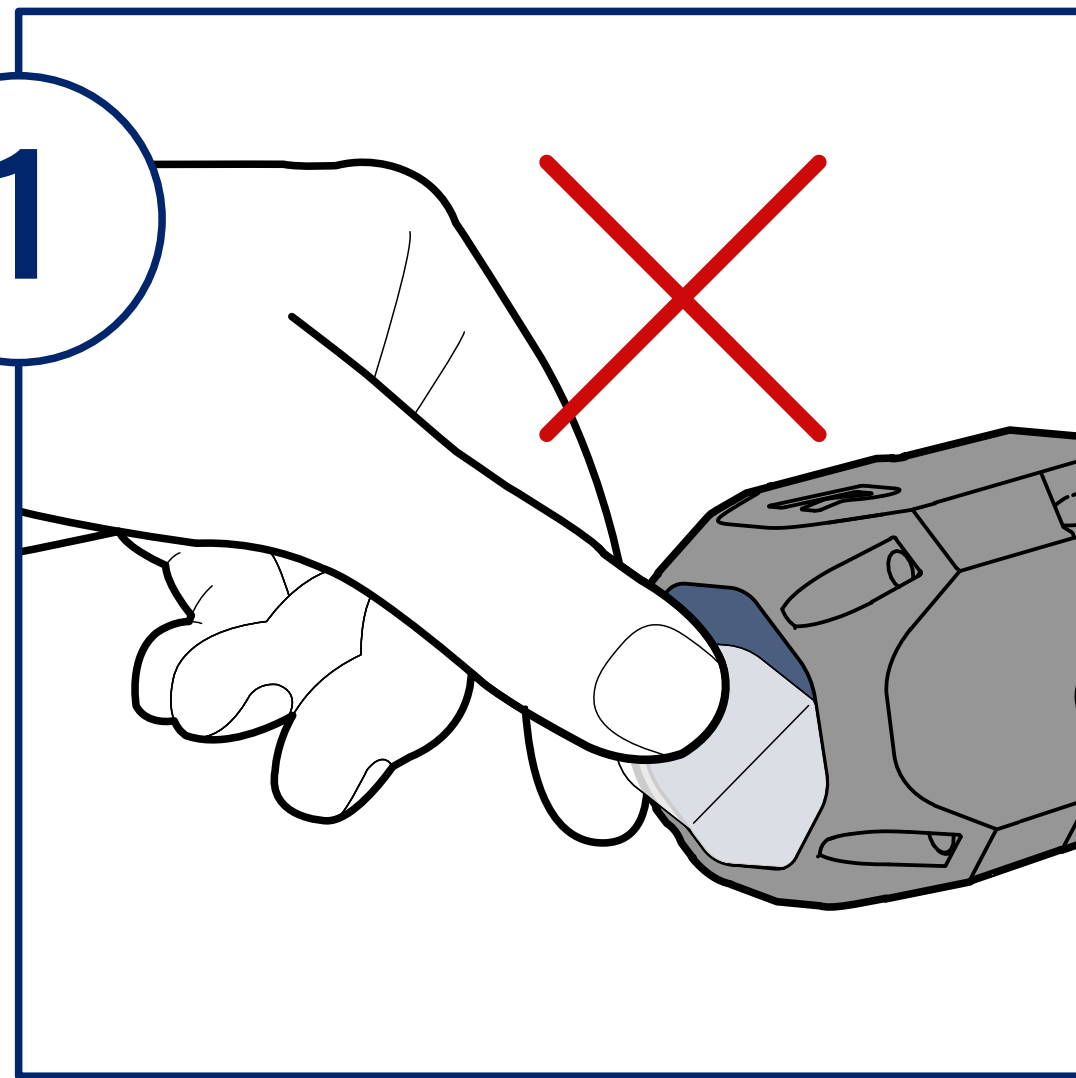

2

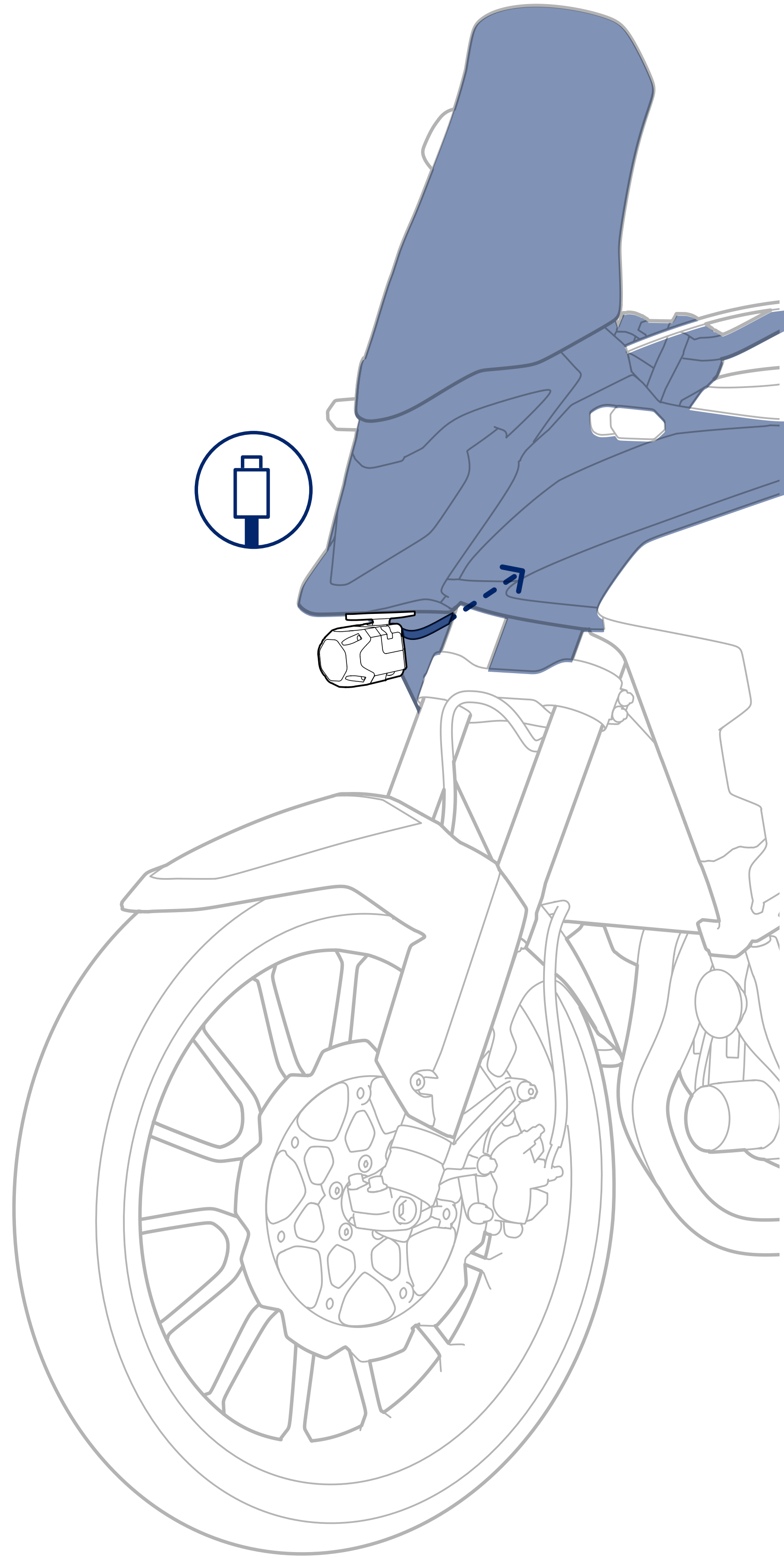
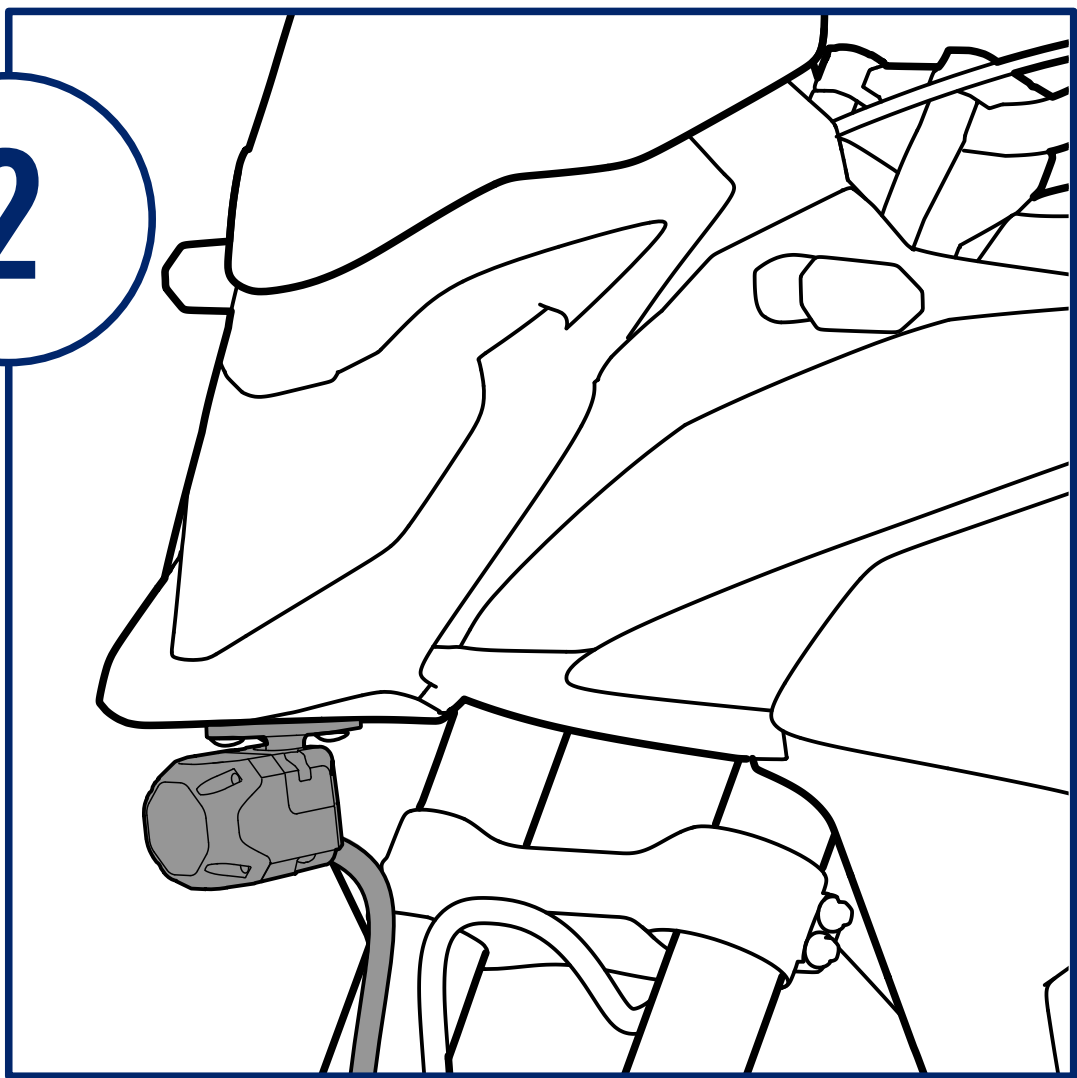

4

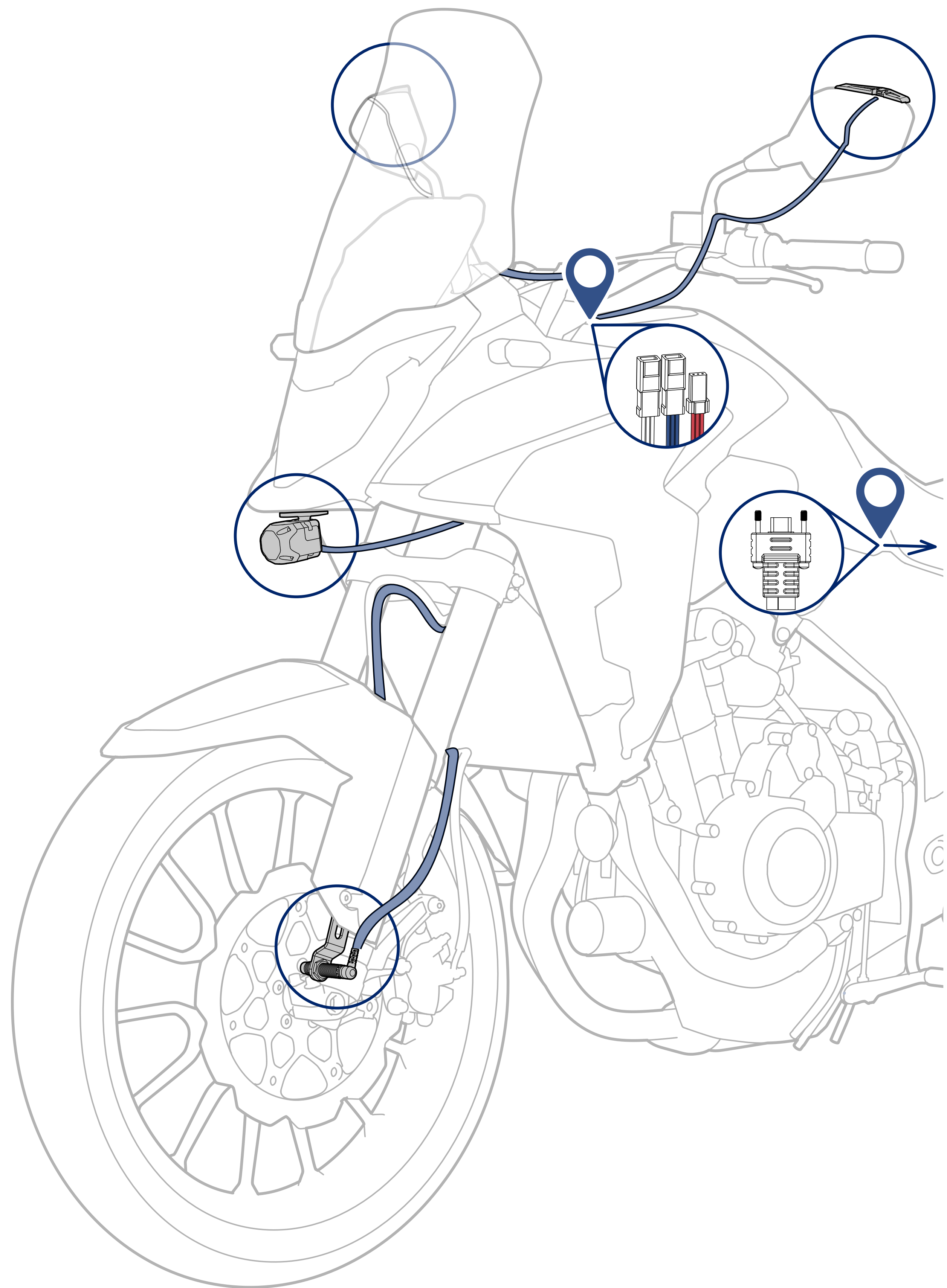
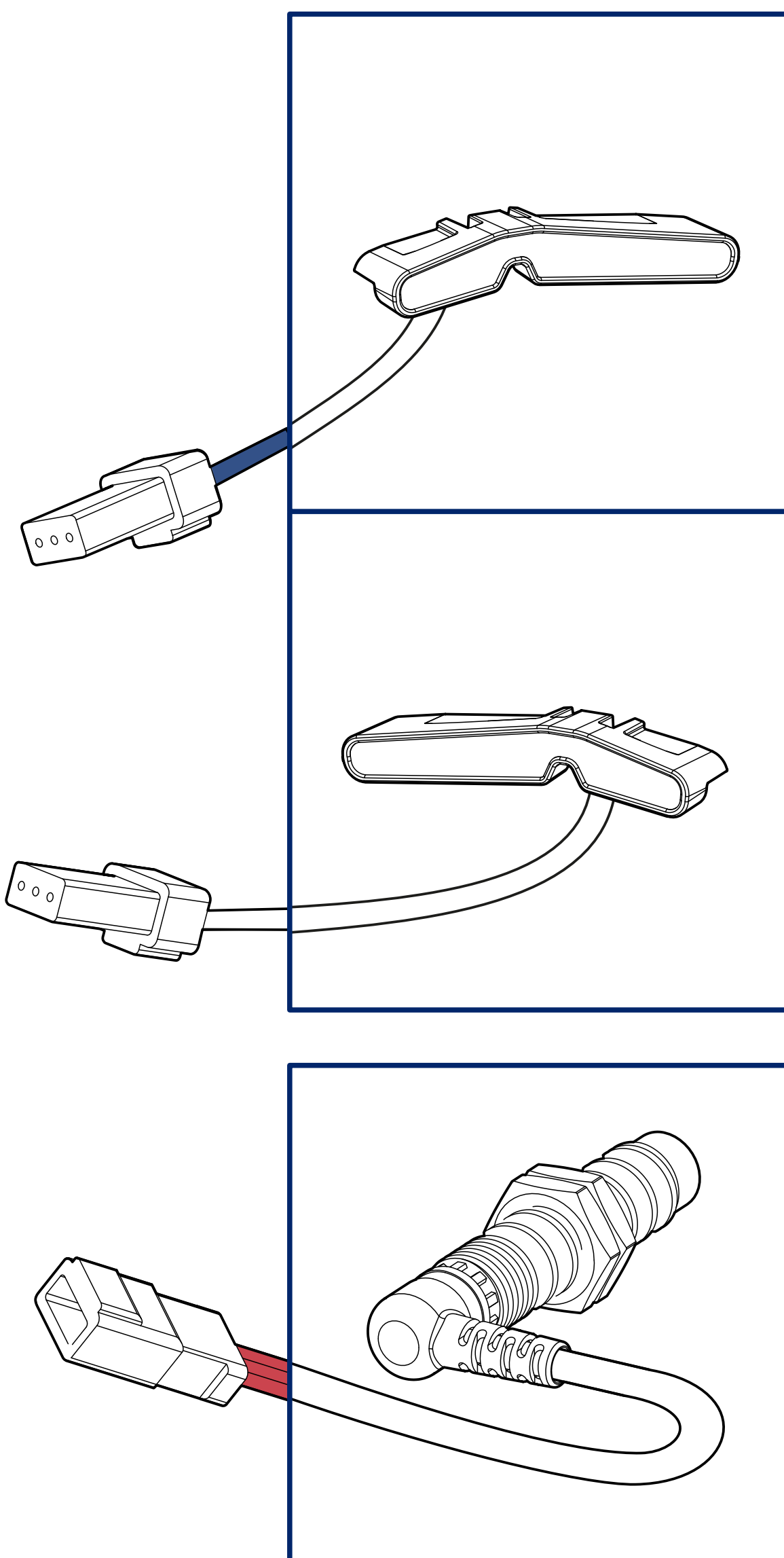
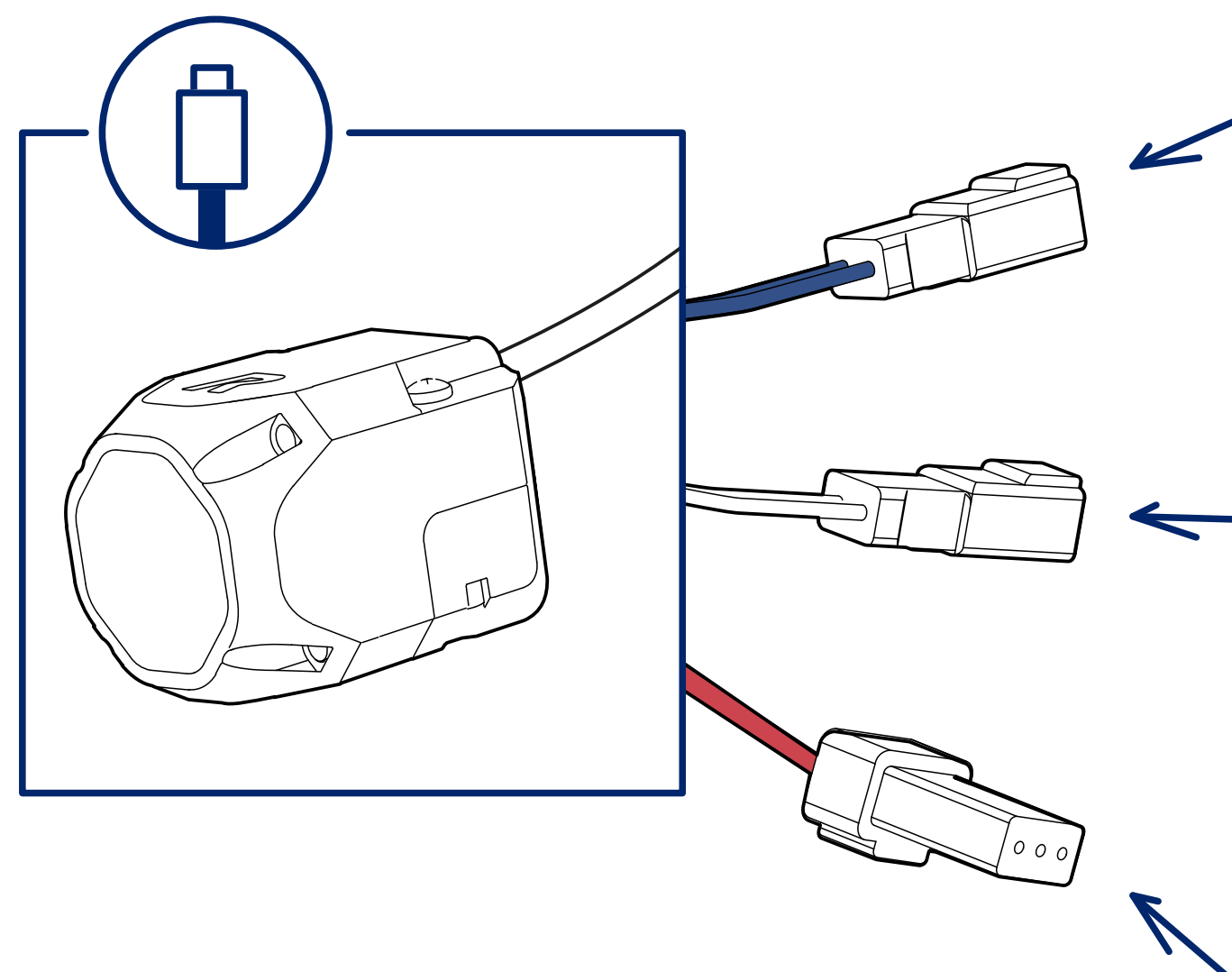
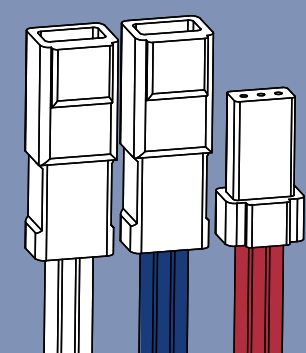
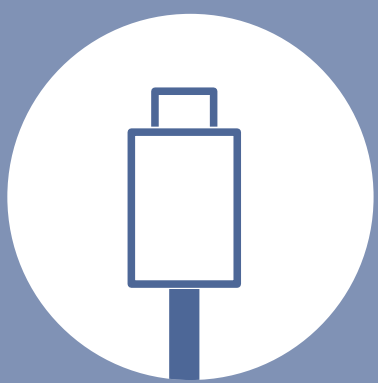

5

i

Find location

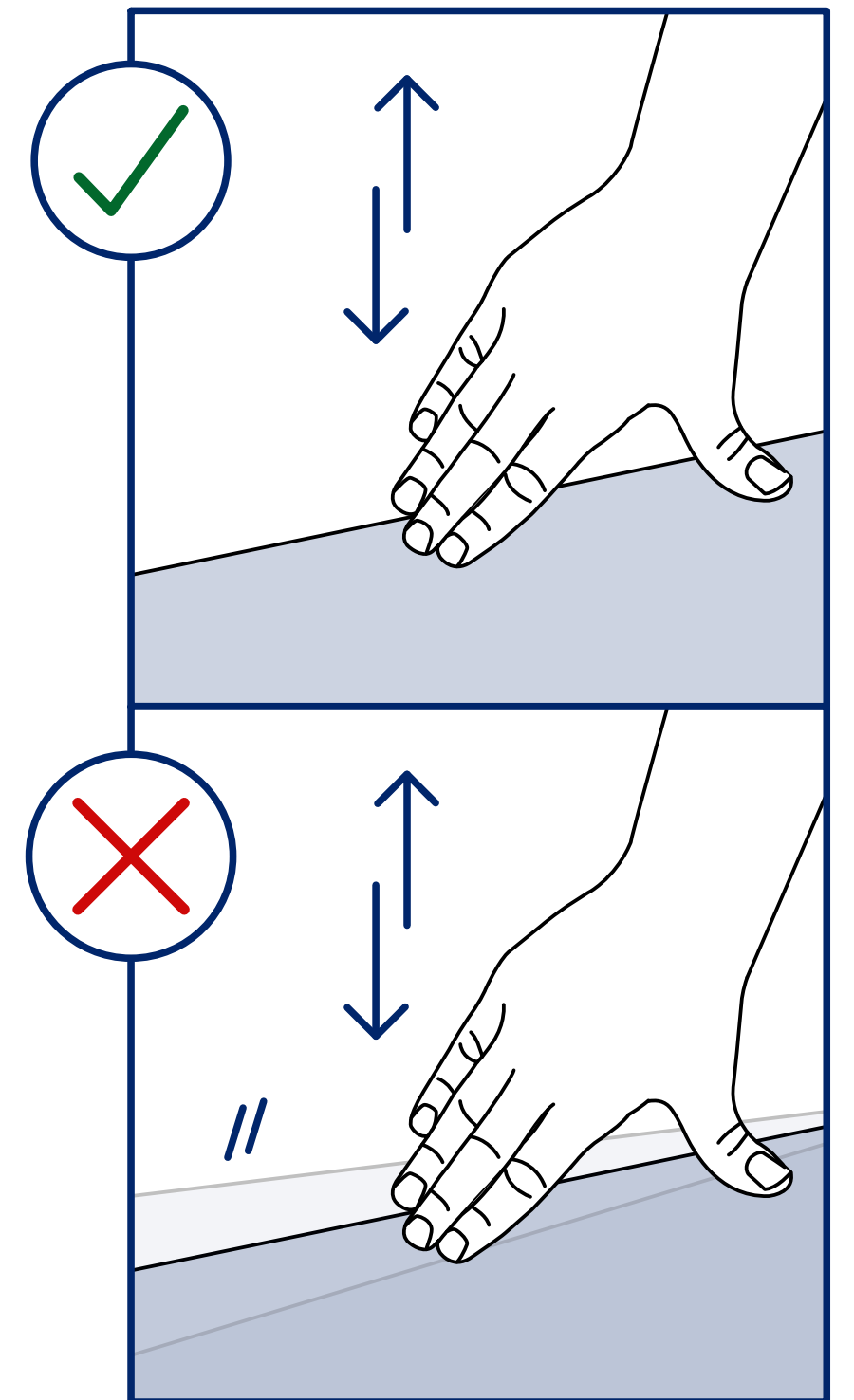
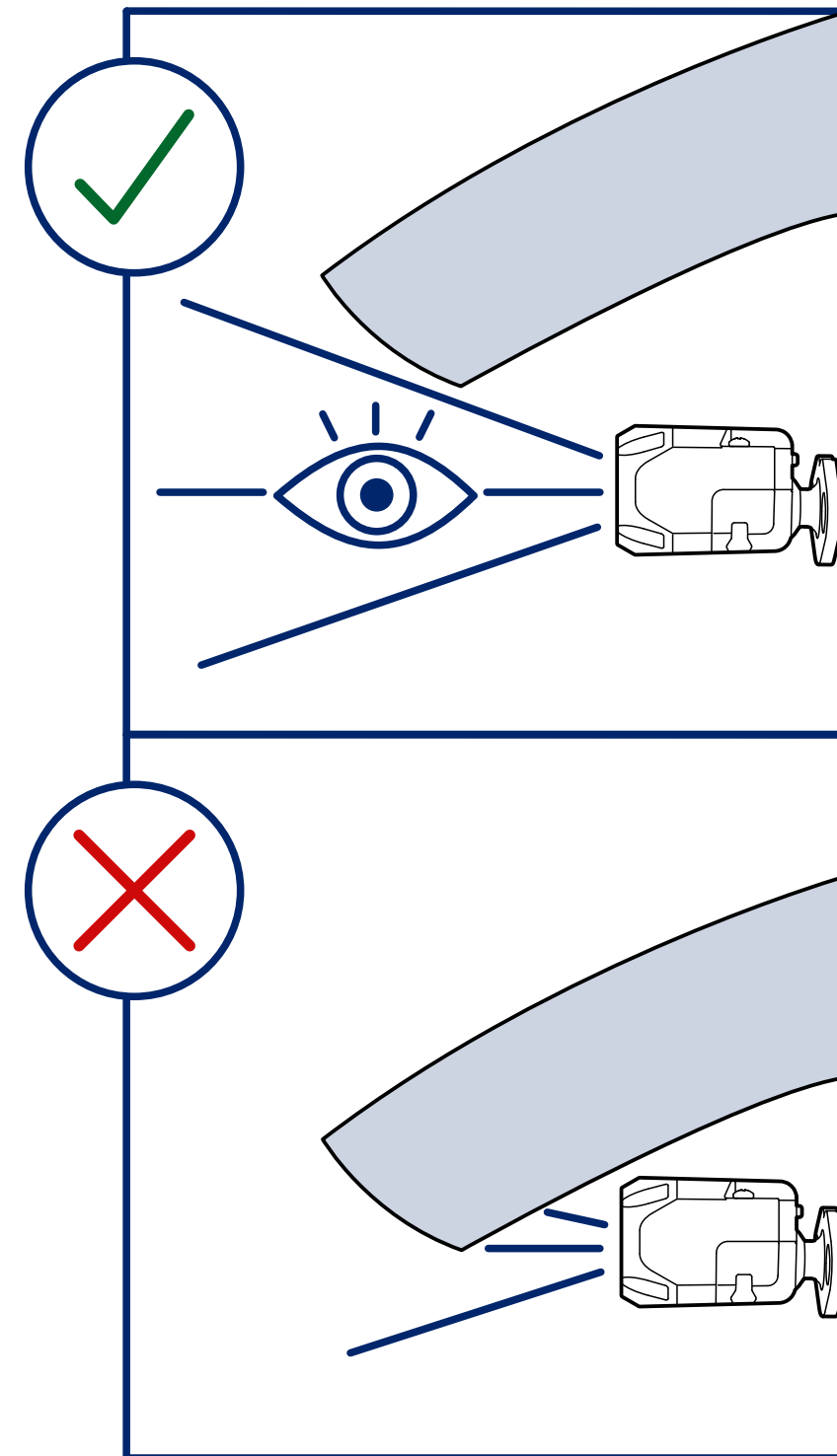
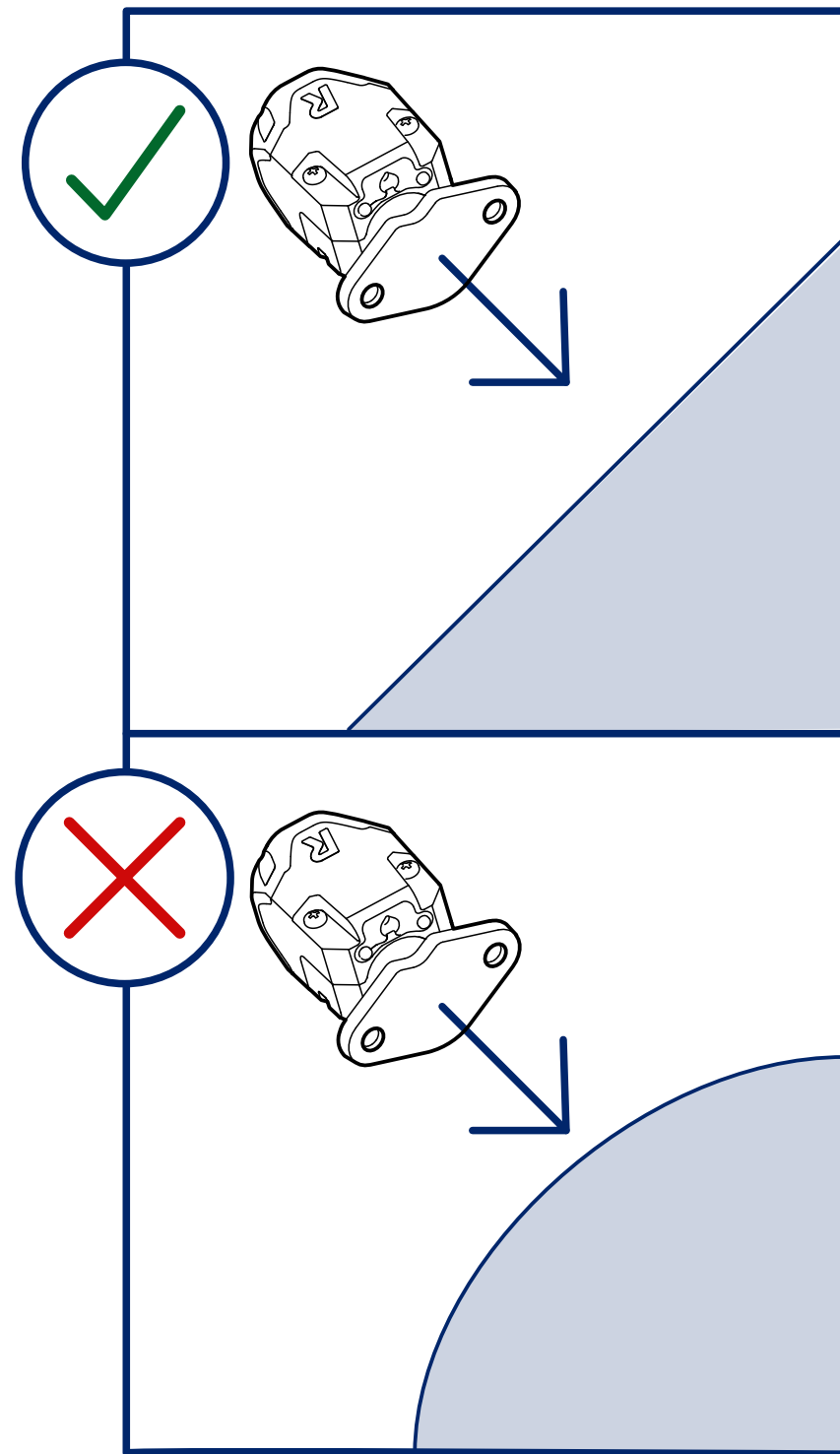
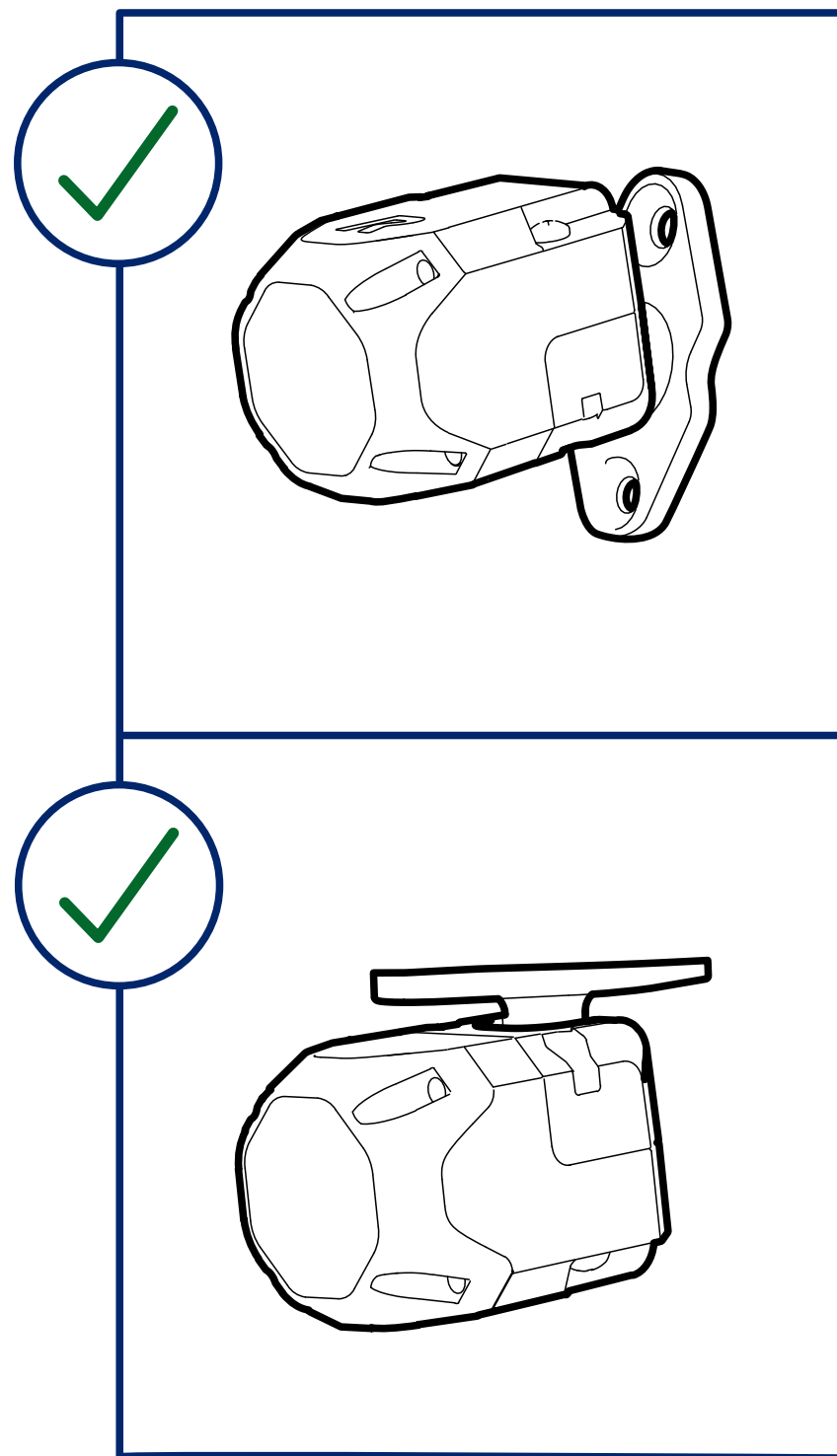
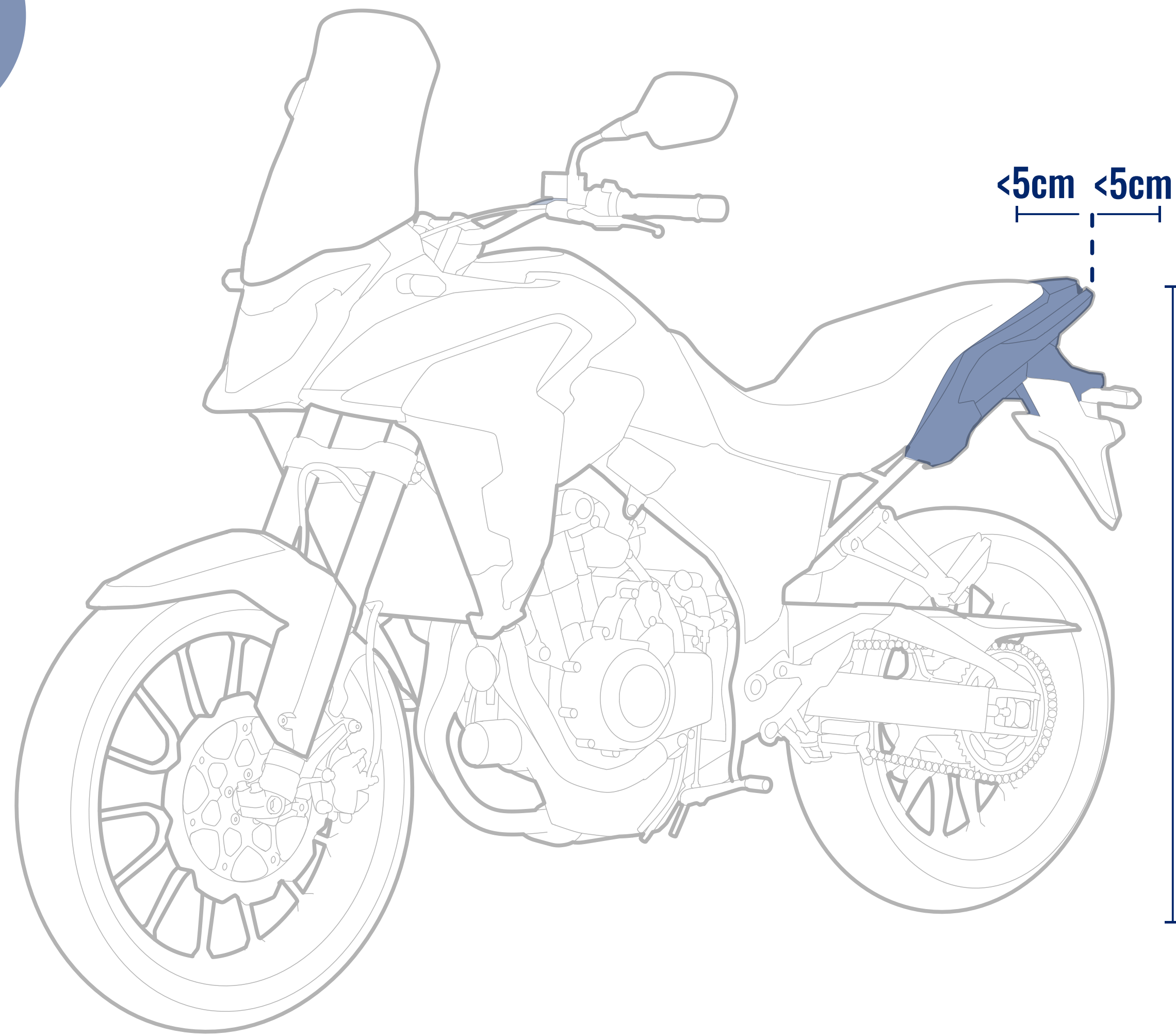
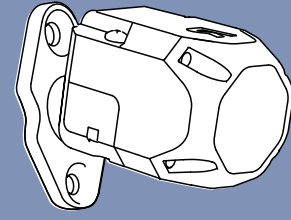

5

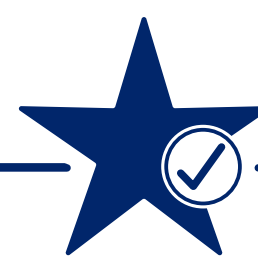
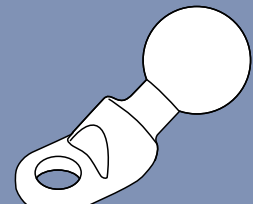
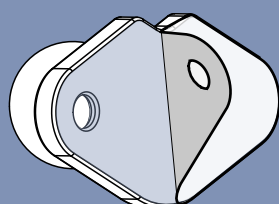
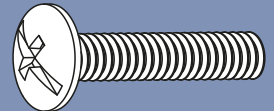
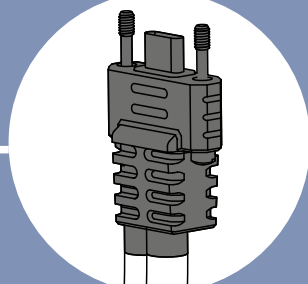
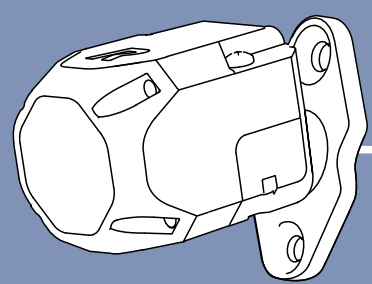

Preferred

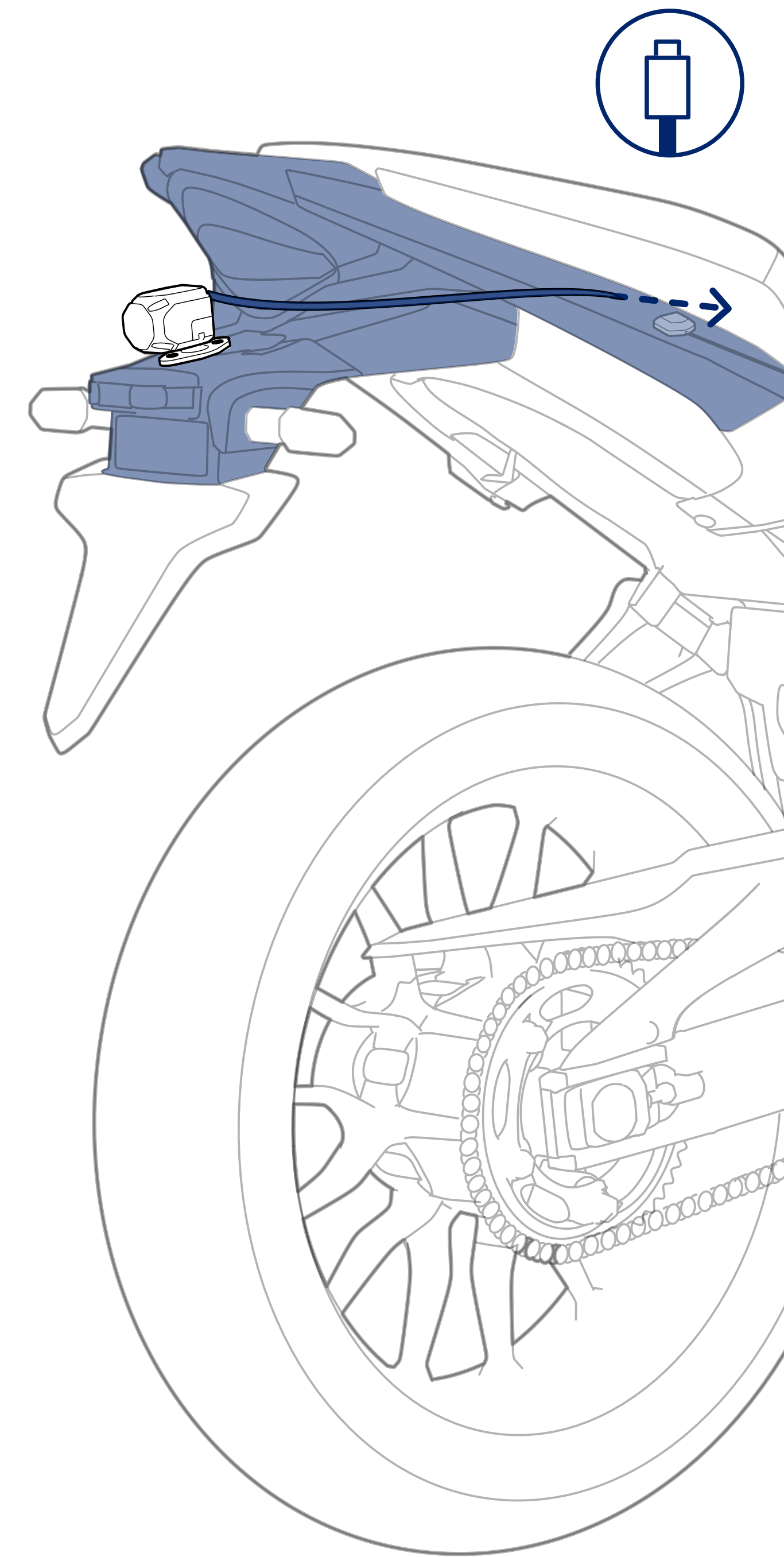
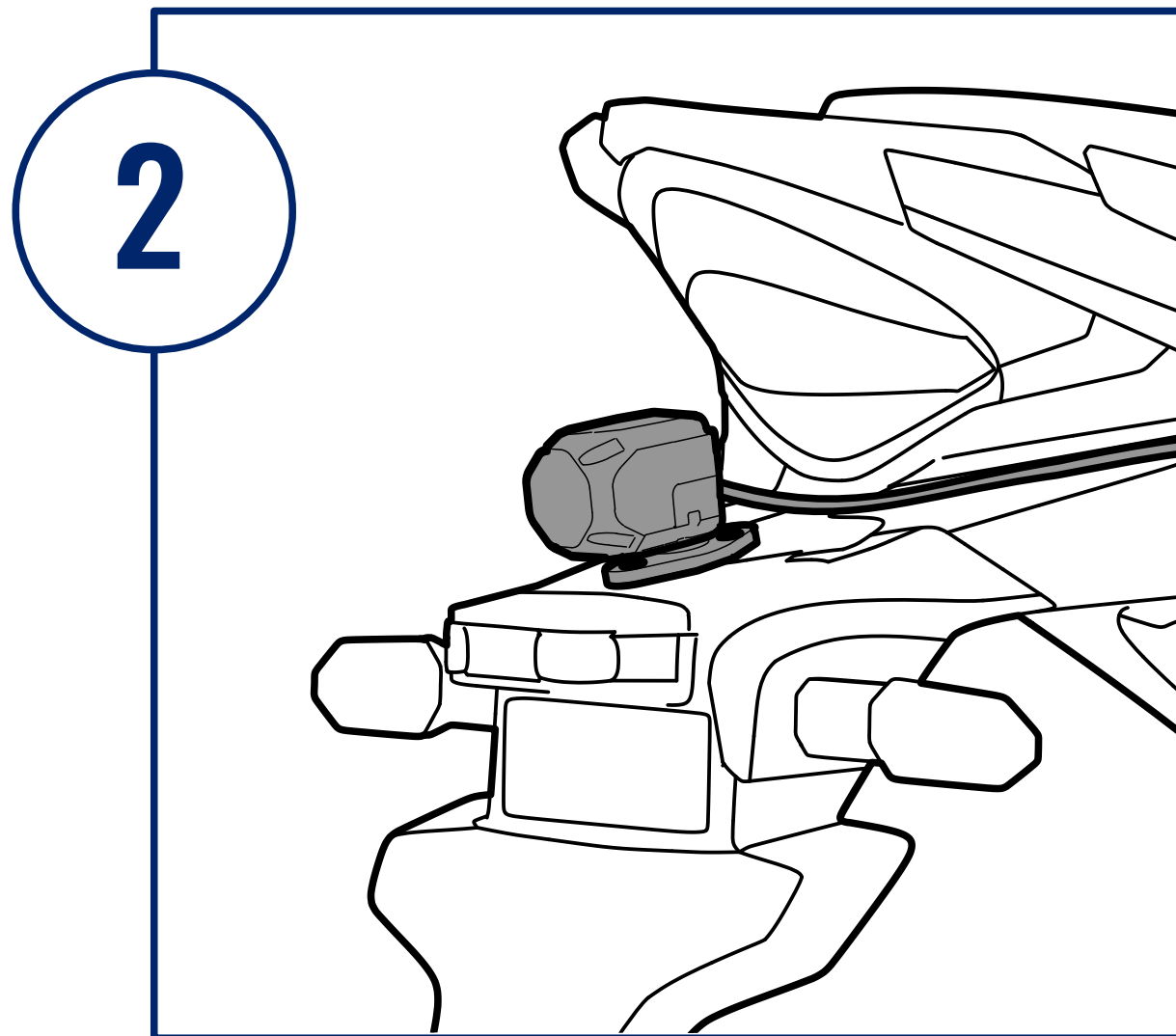
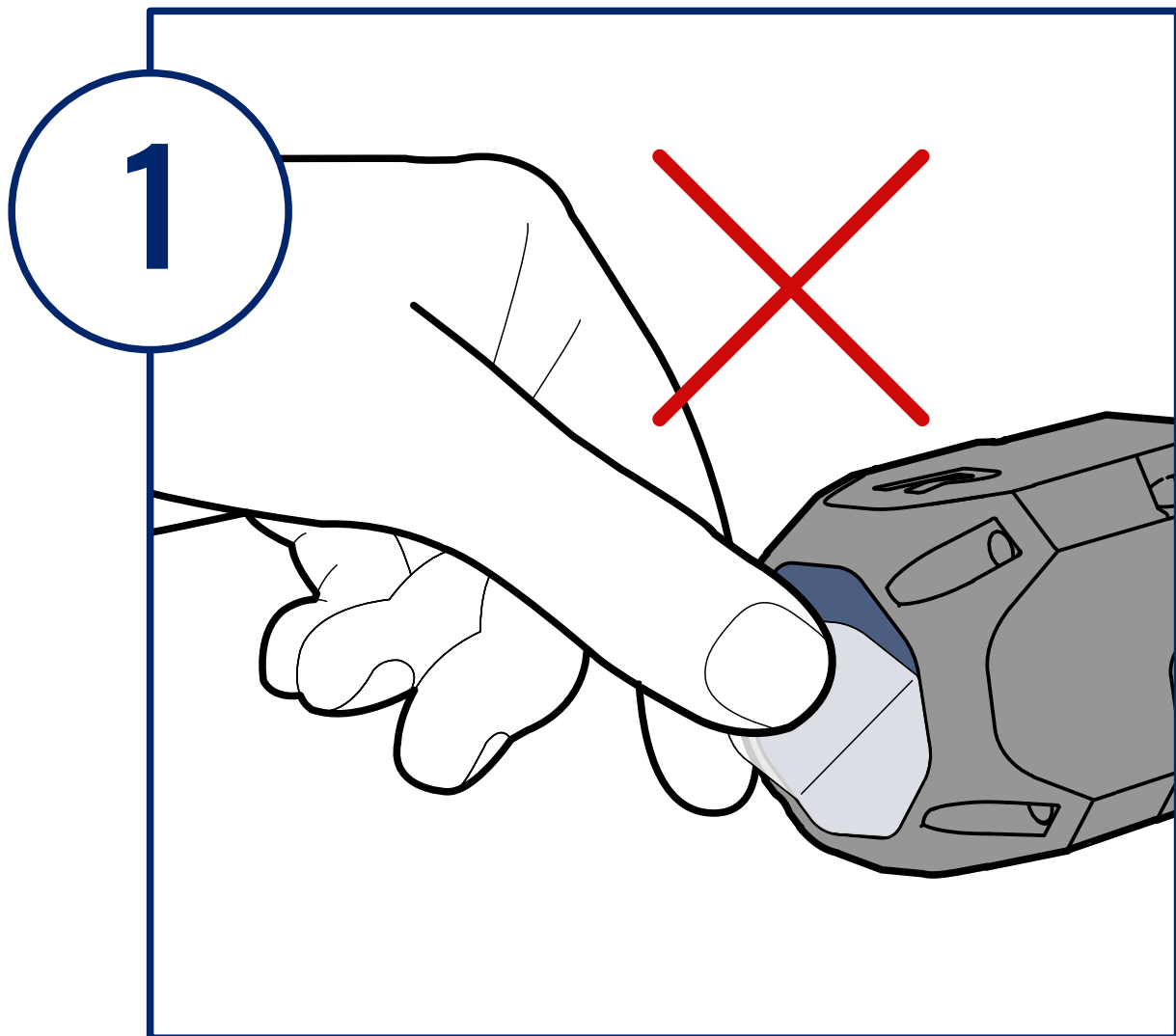
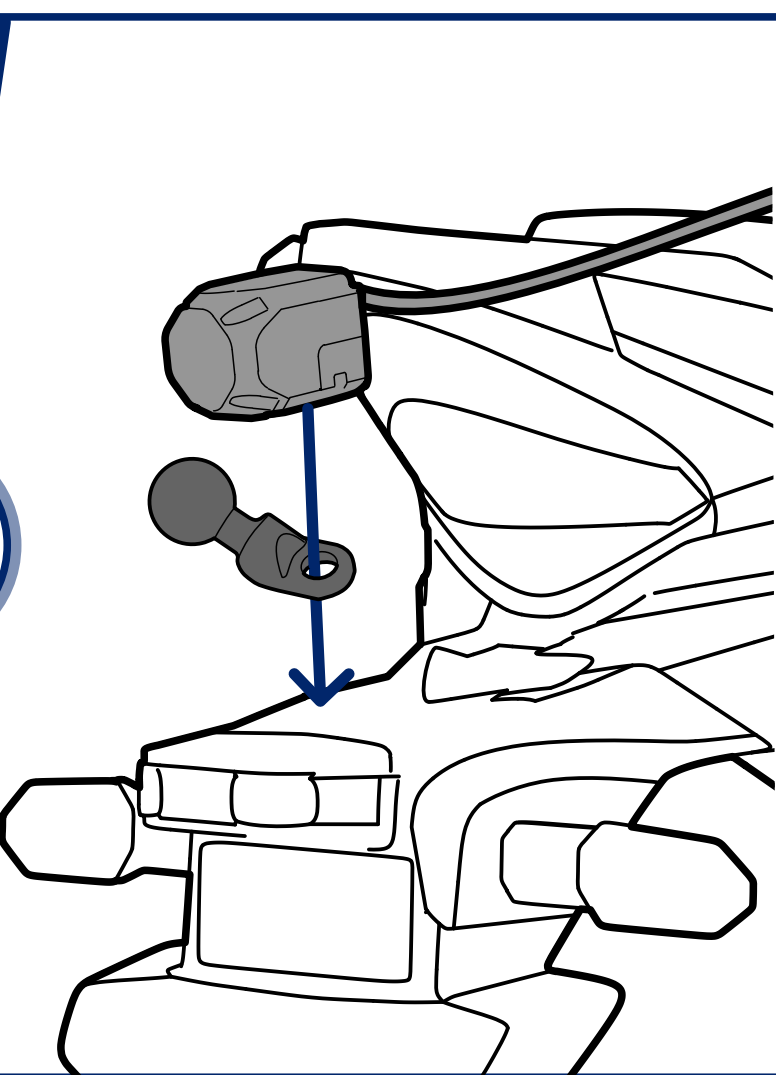
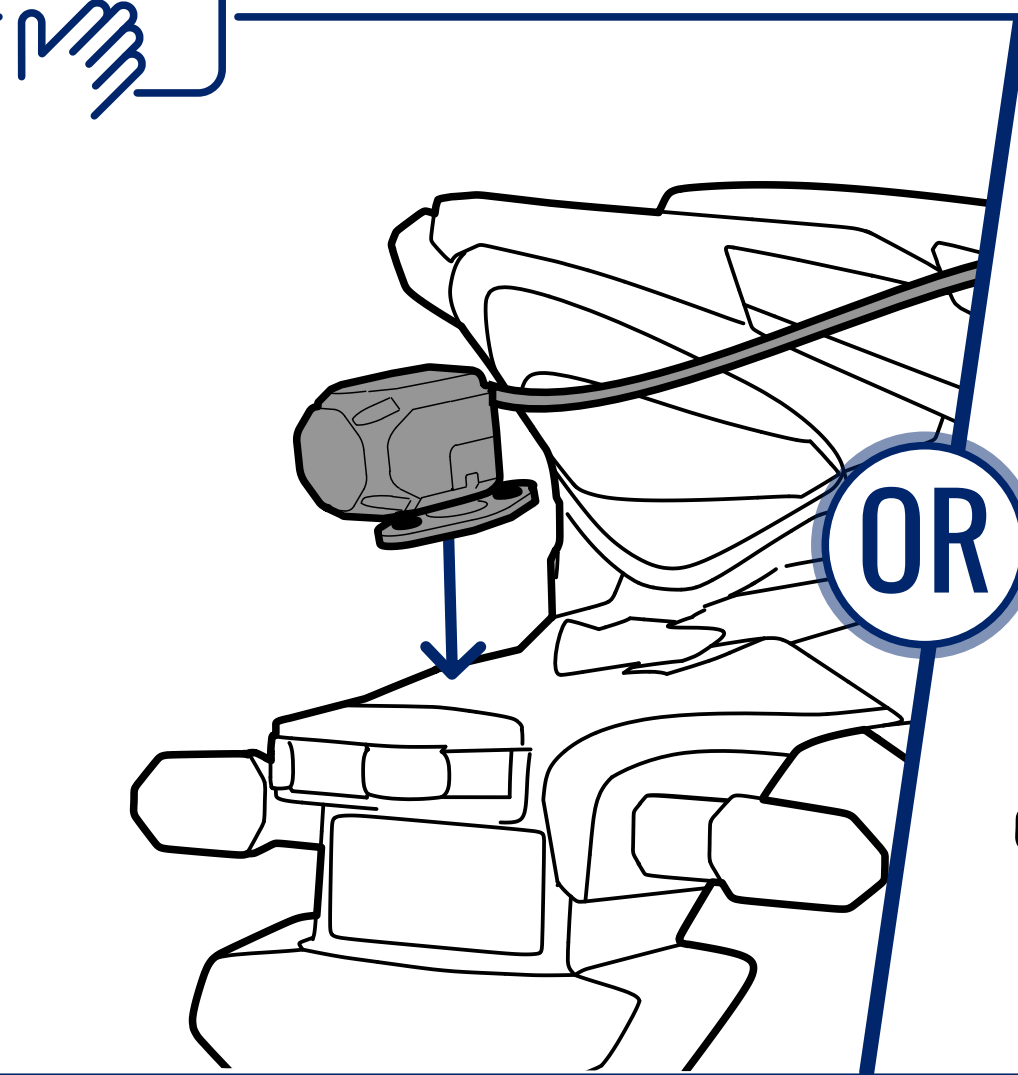
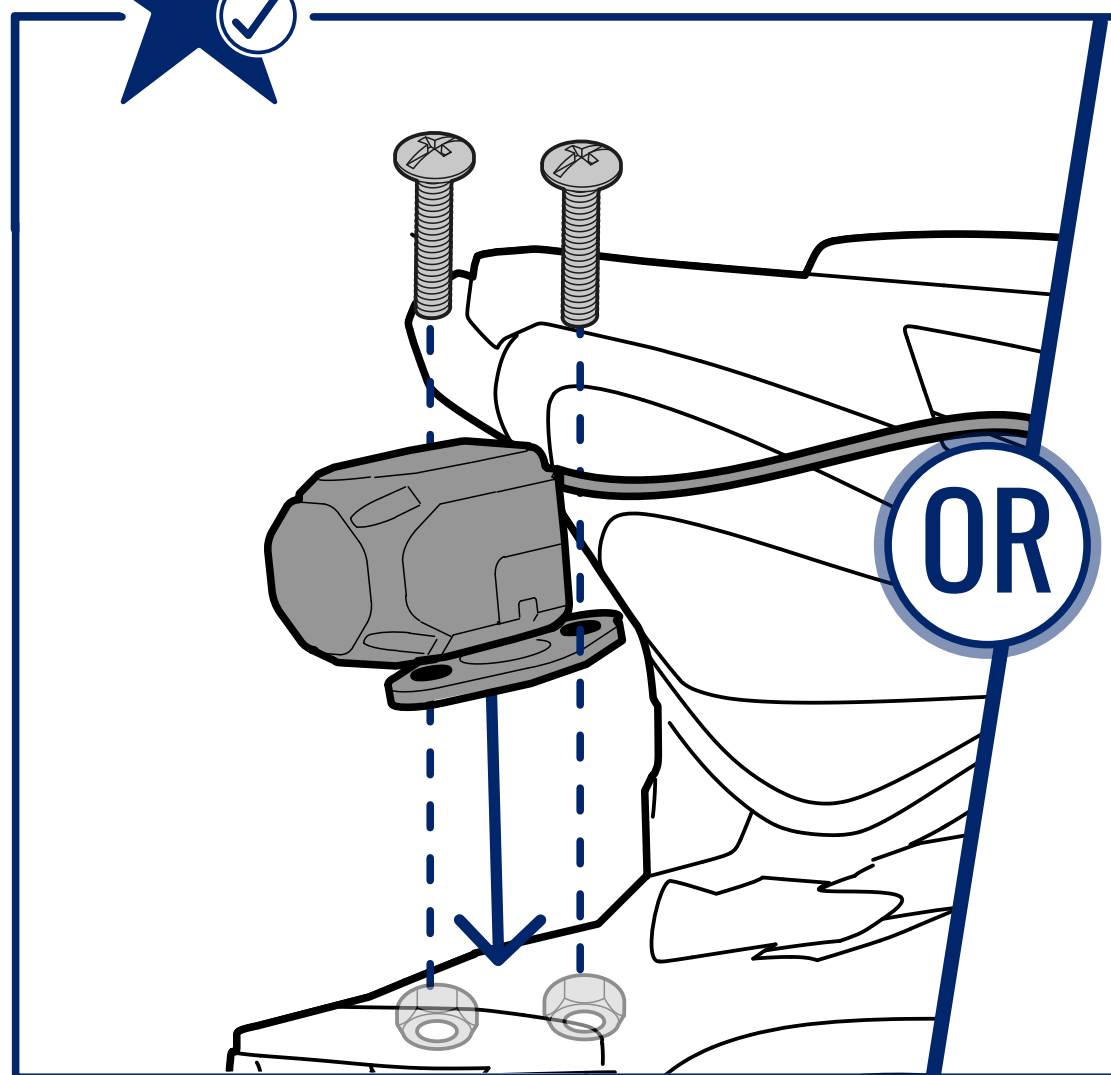

6

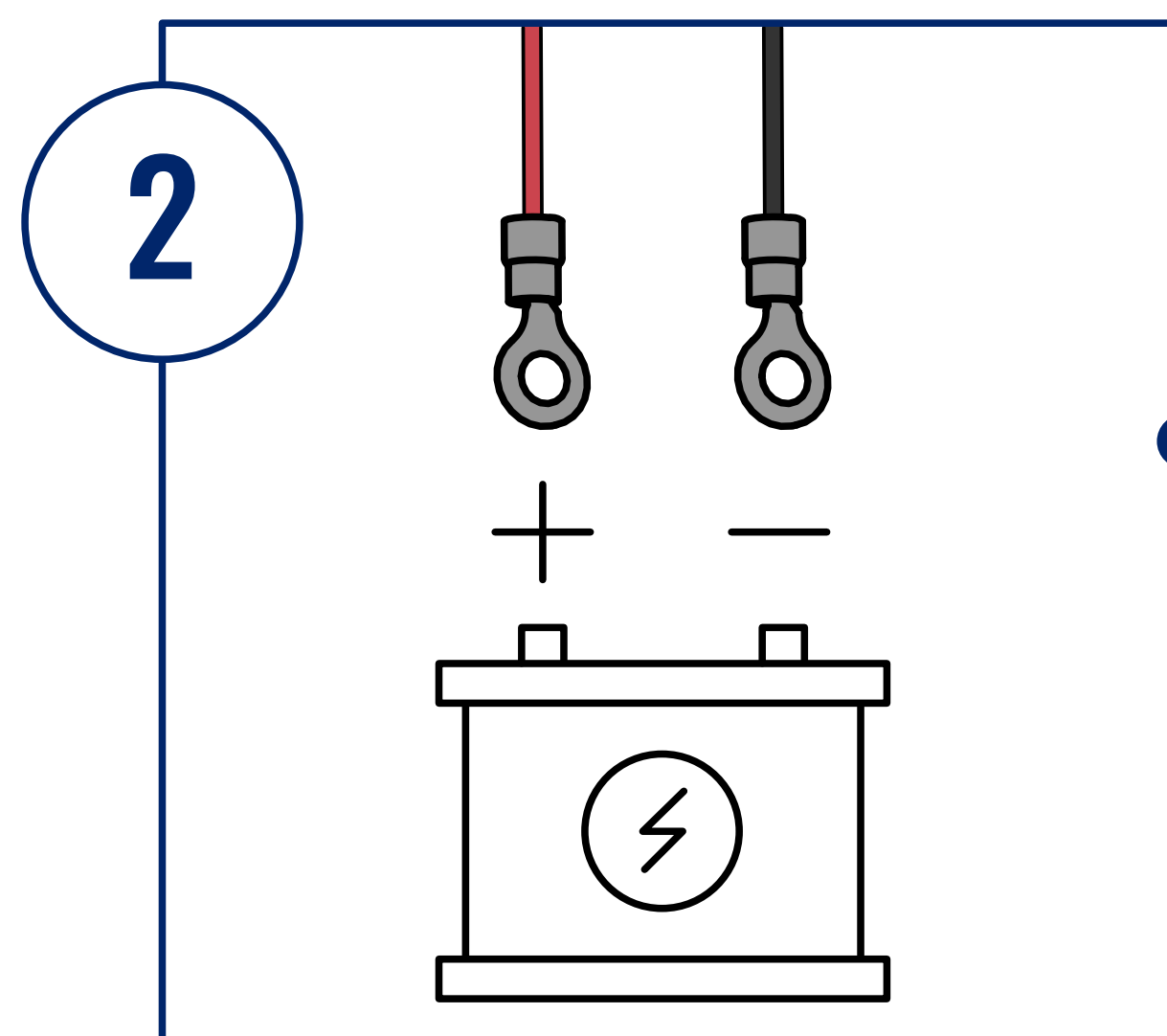
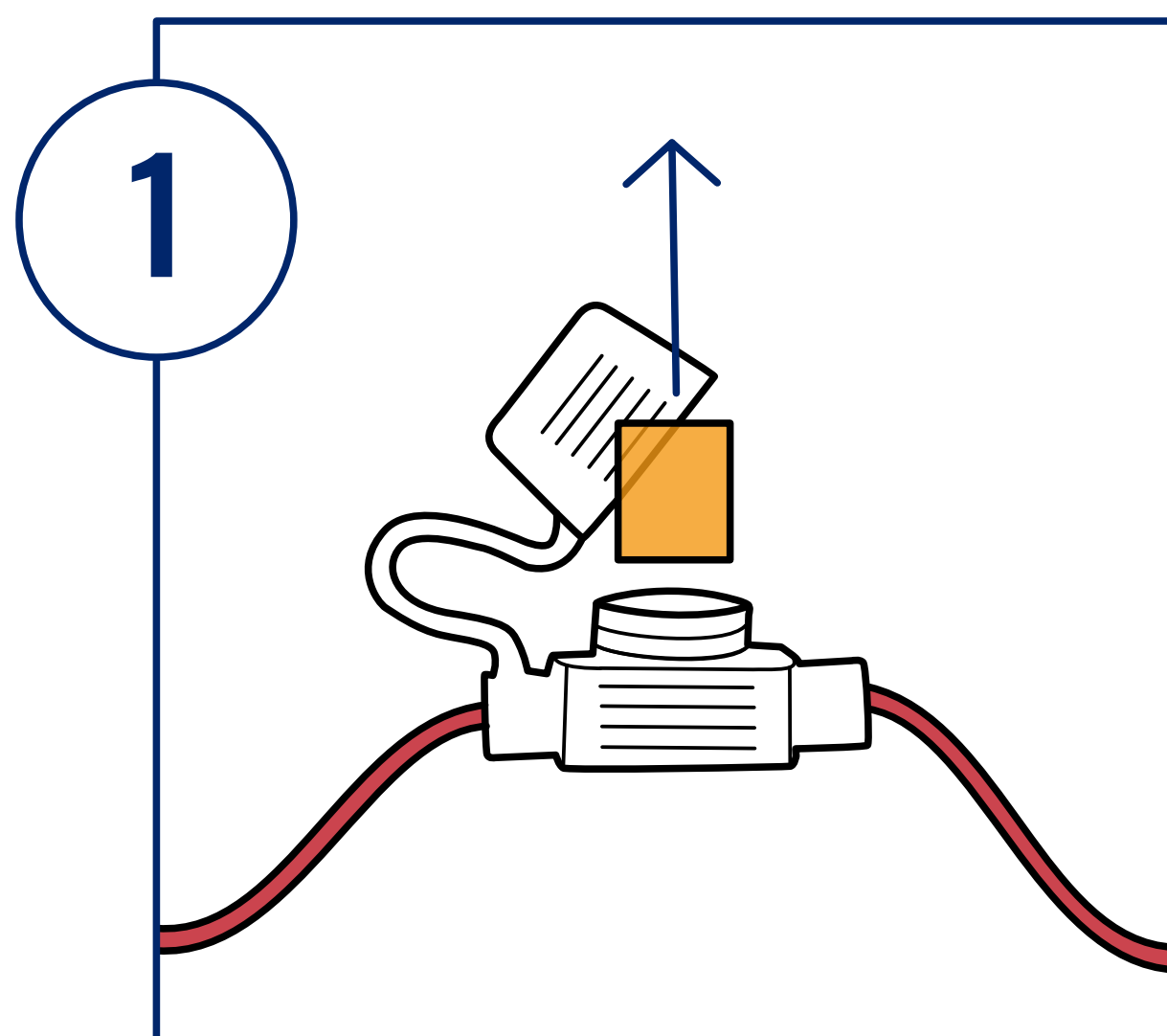
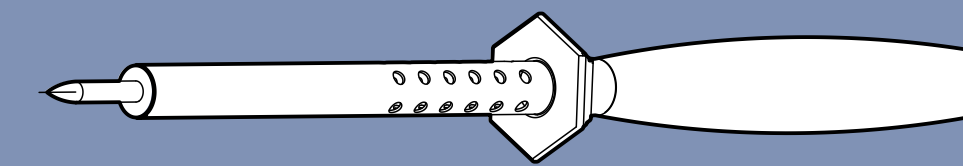
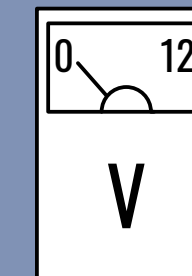
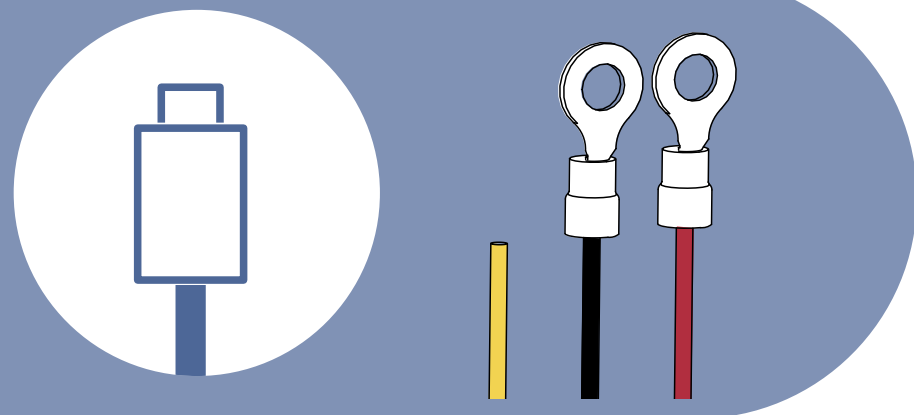

Red wire - battery positive terminal (+ 12v)
Black wire - battery negative terminal (- 12v)

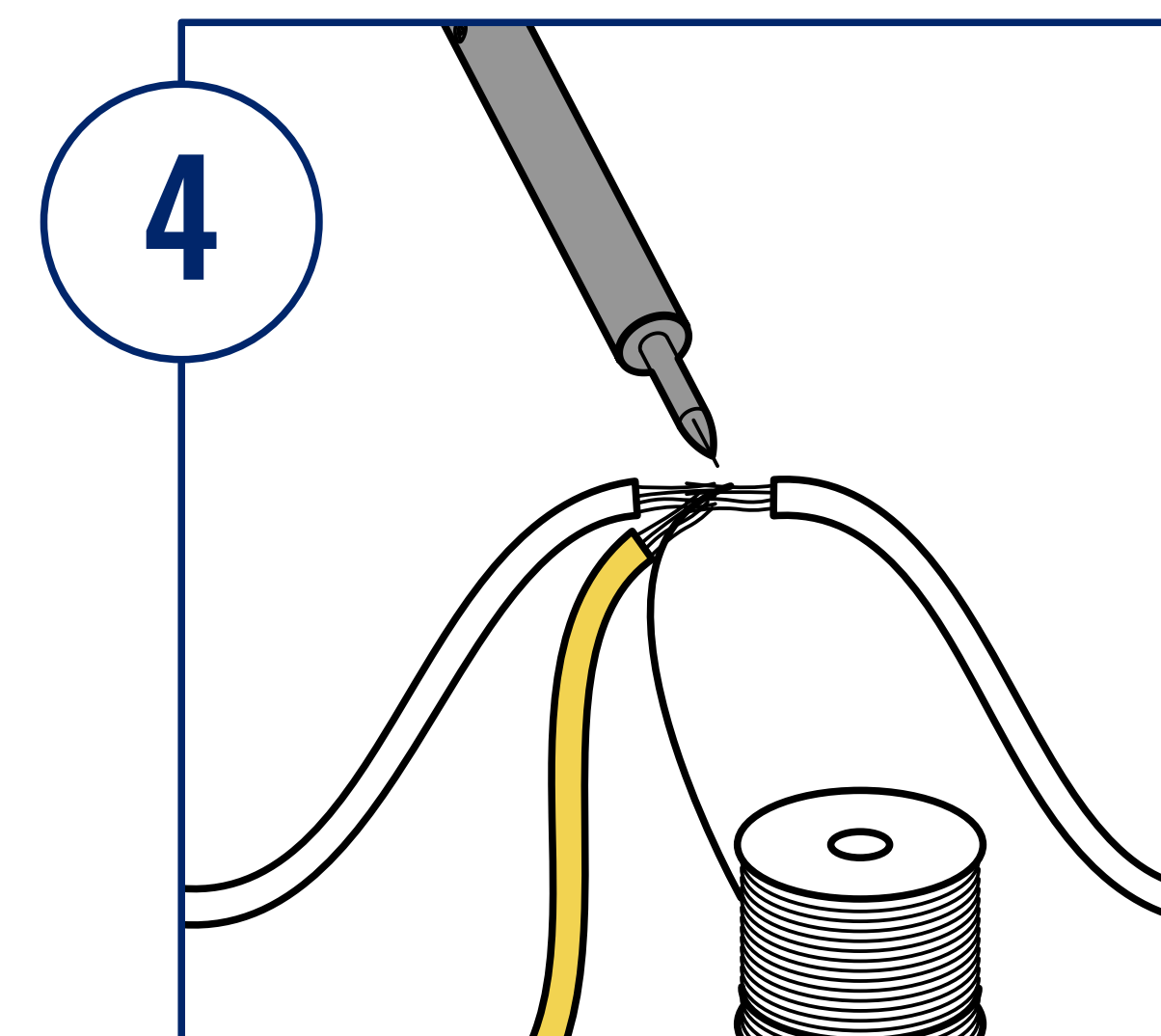
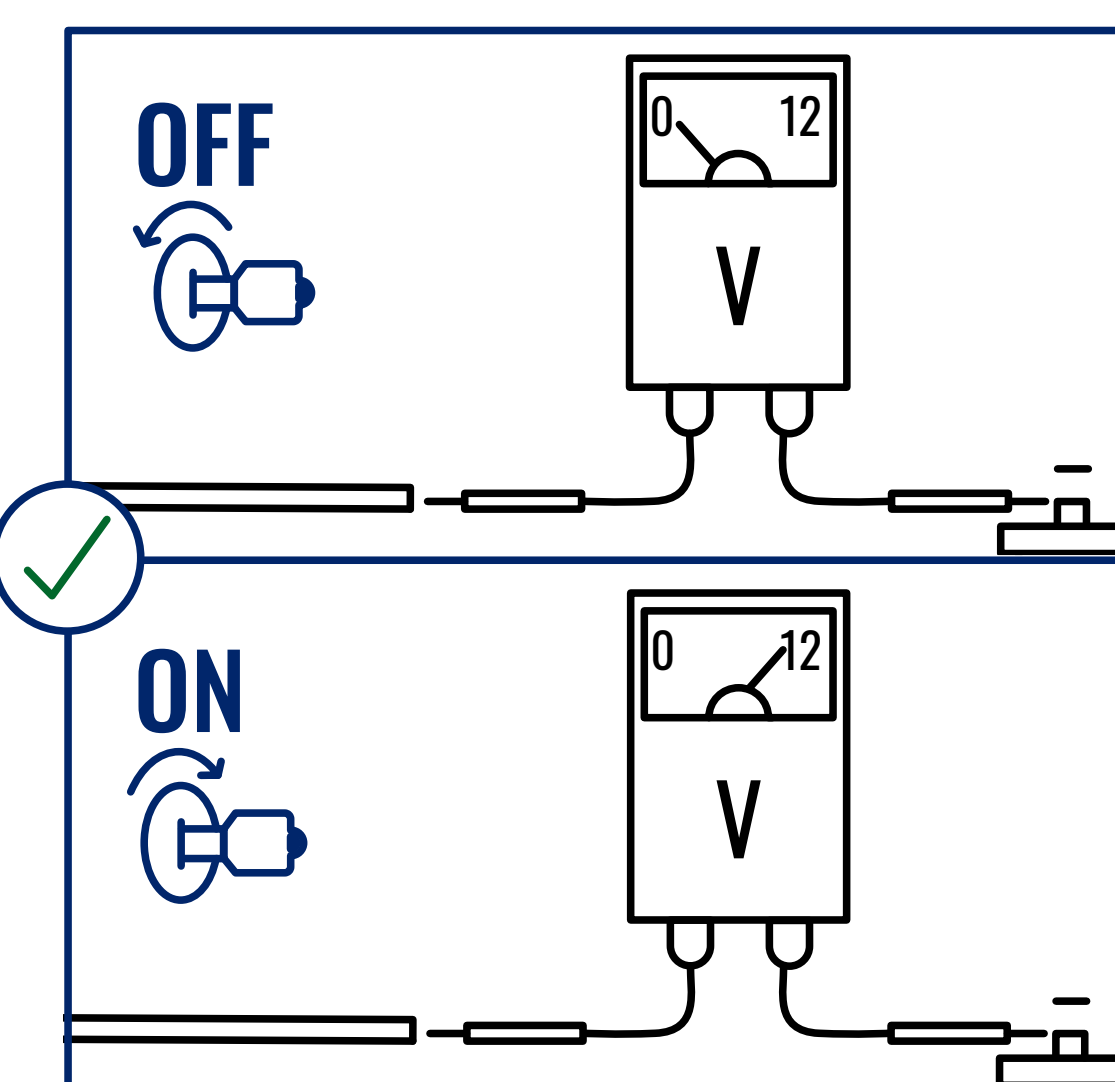
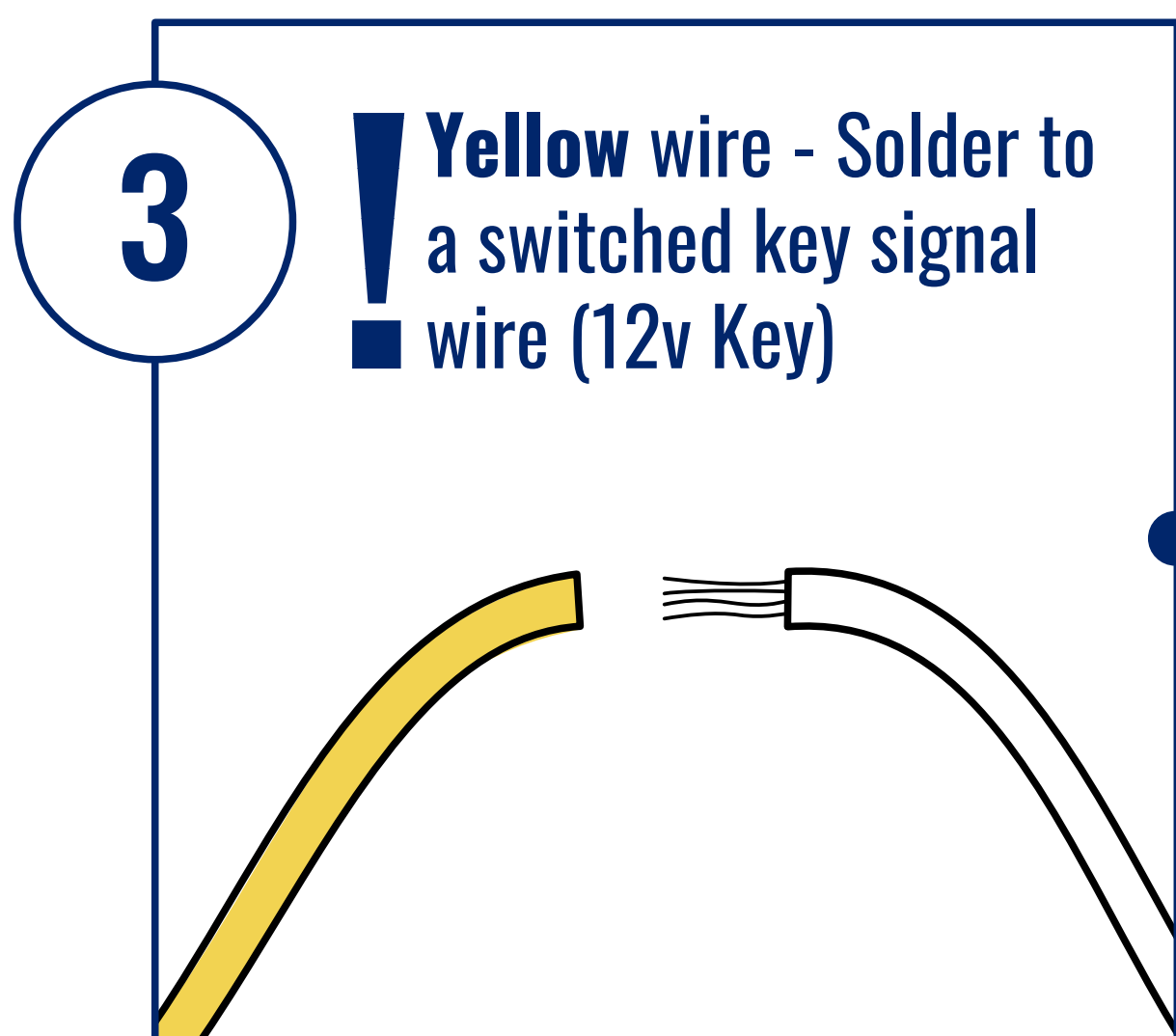

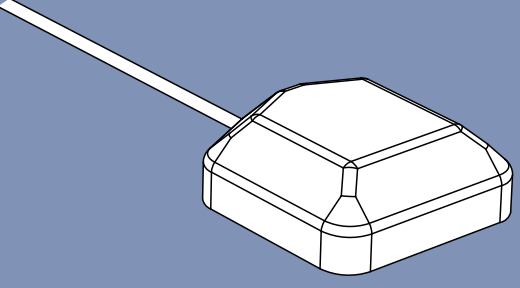
7 

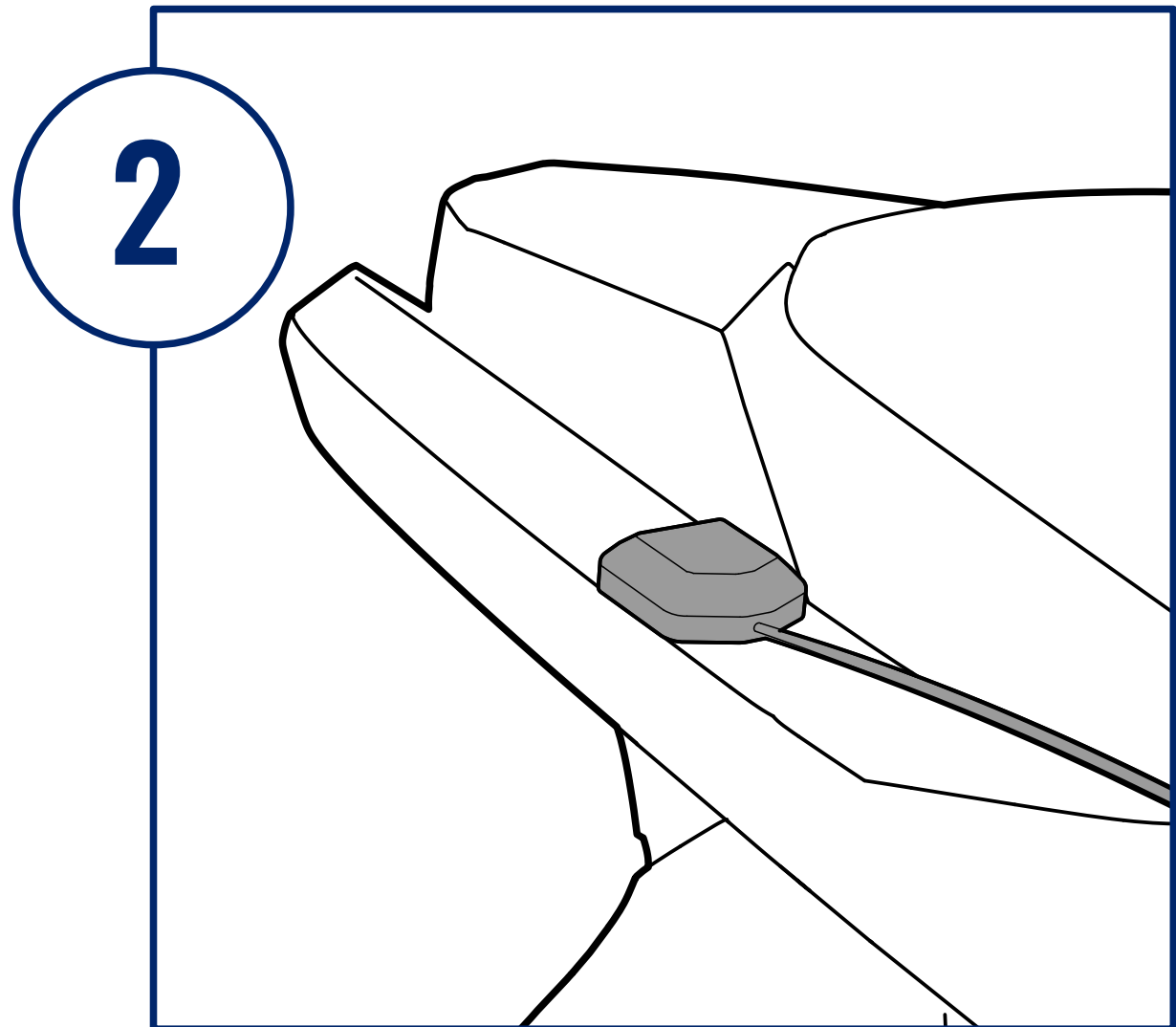
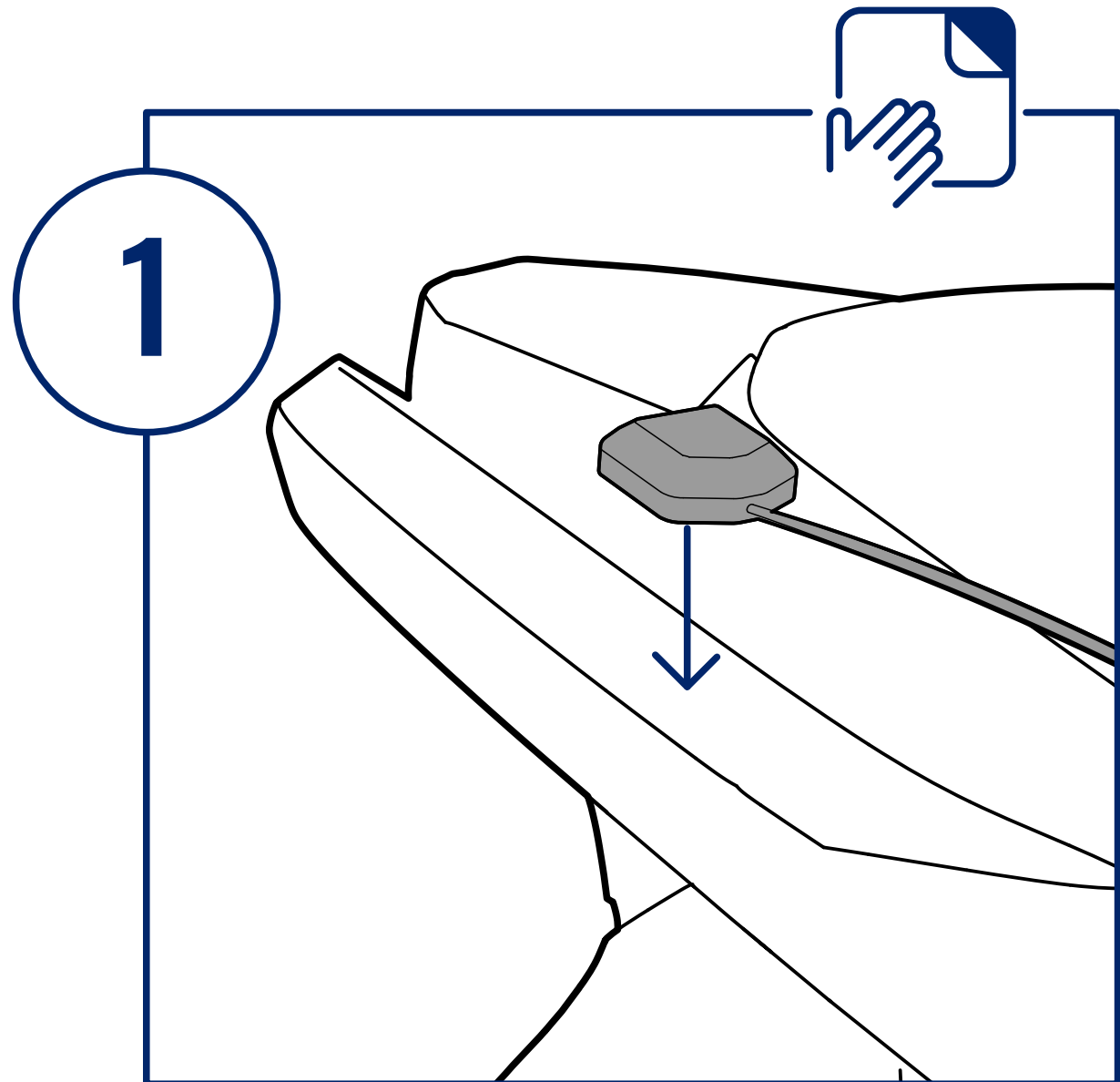
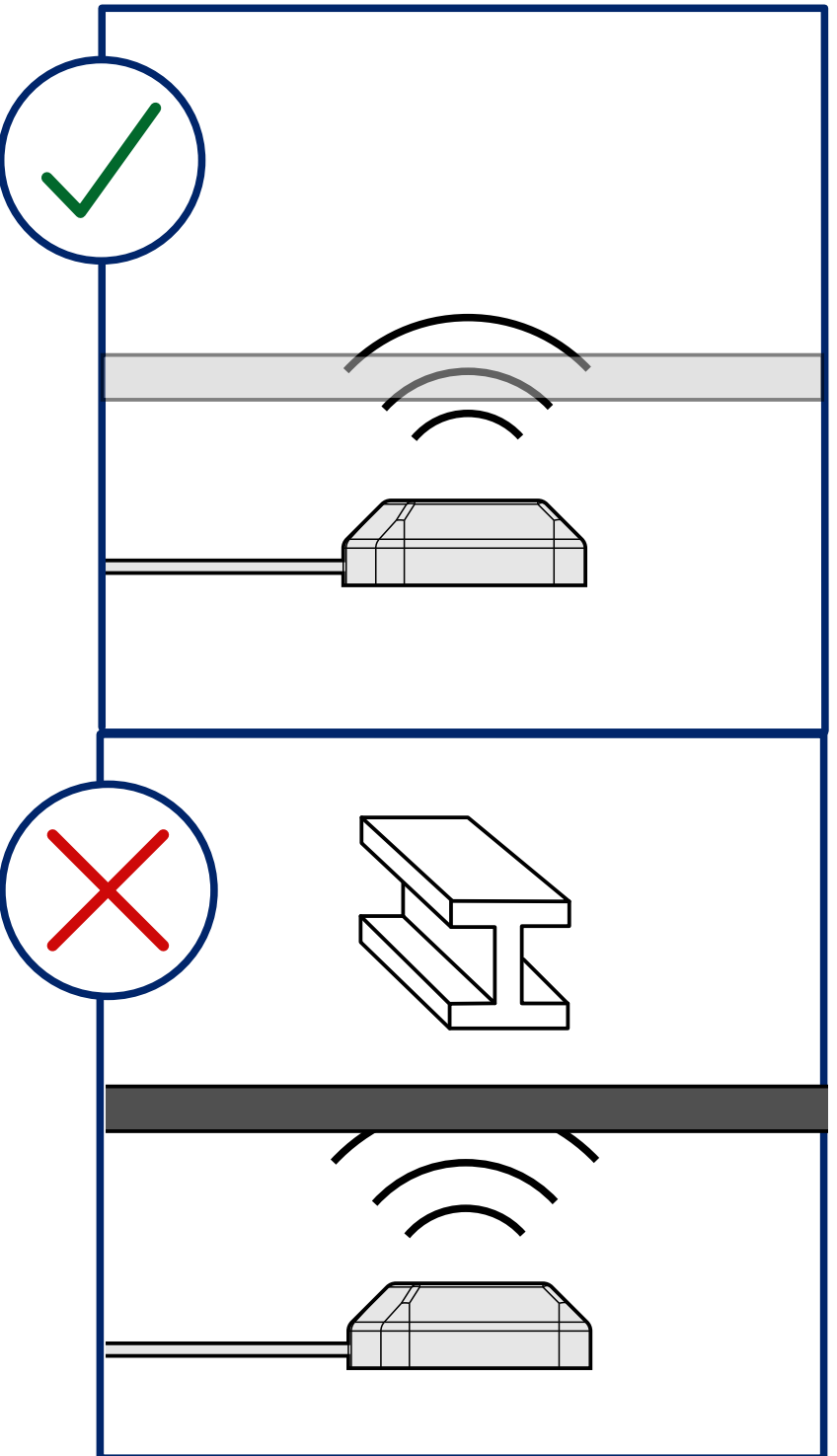
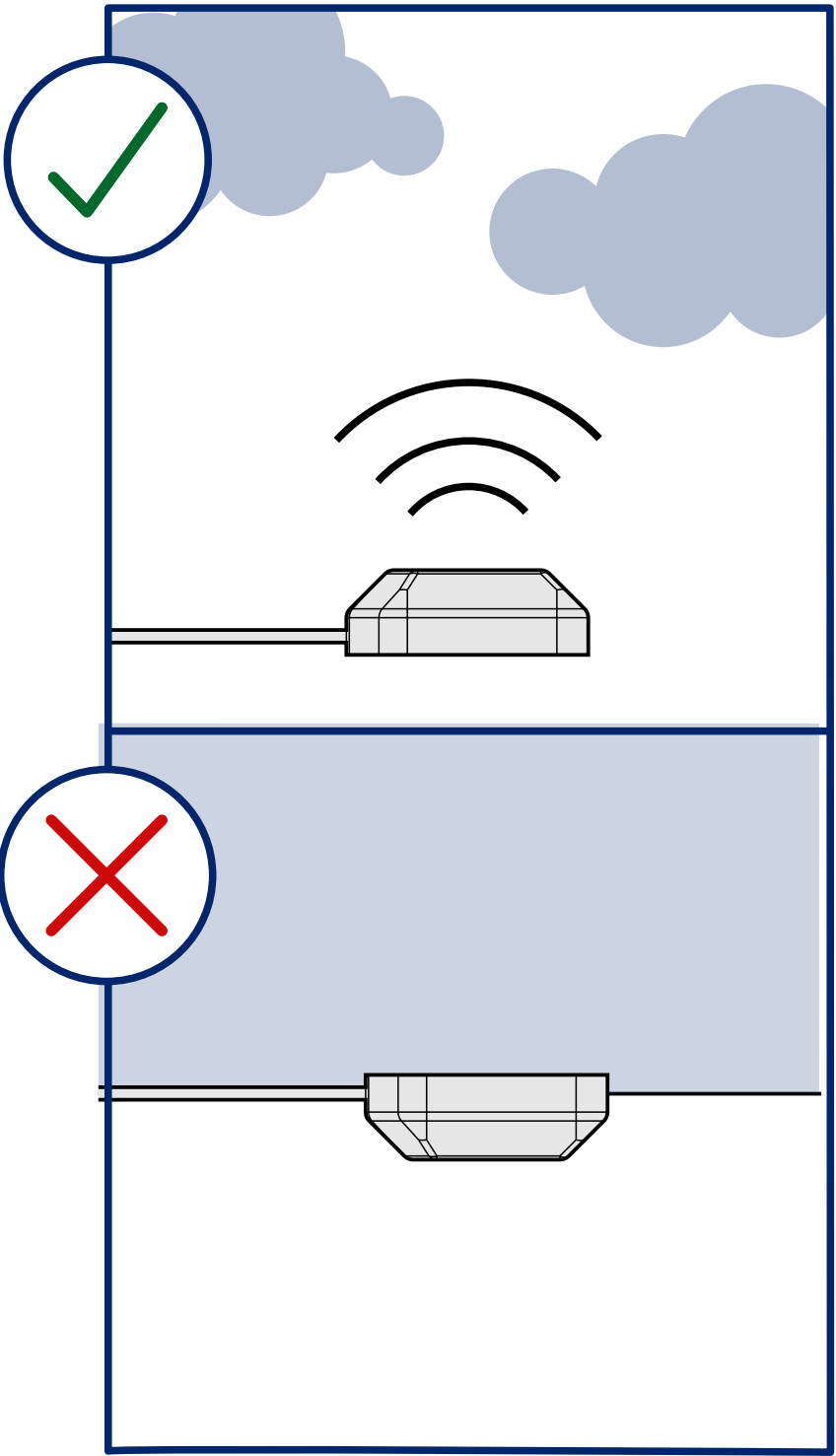
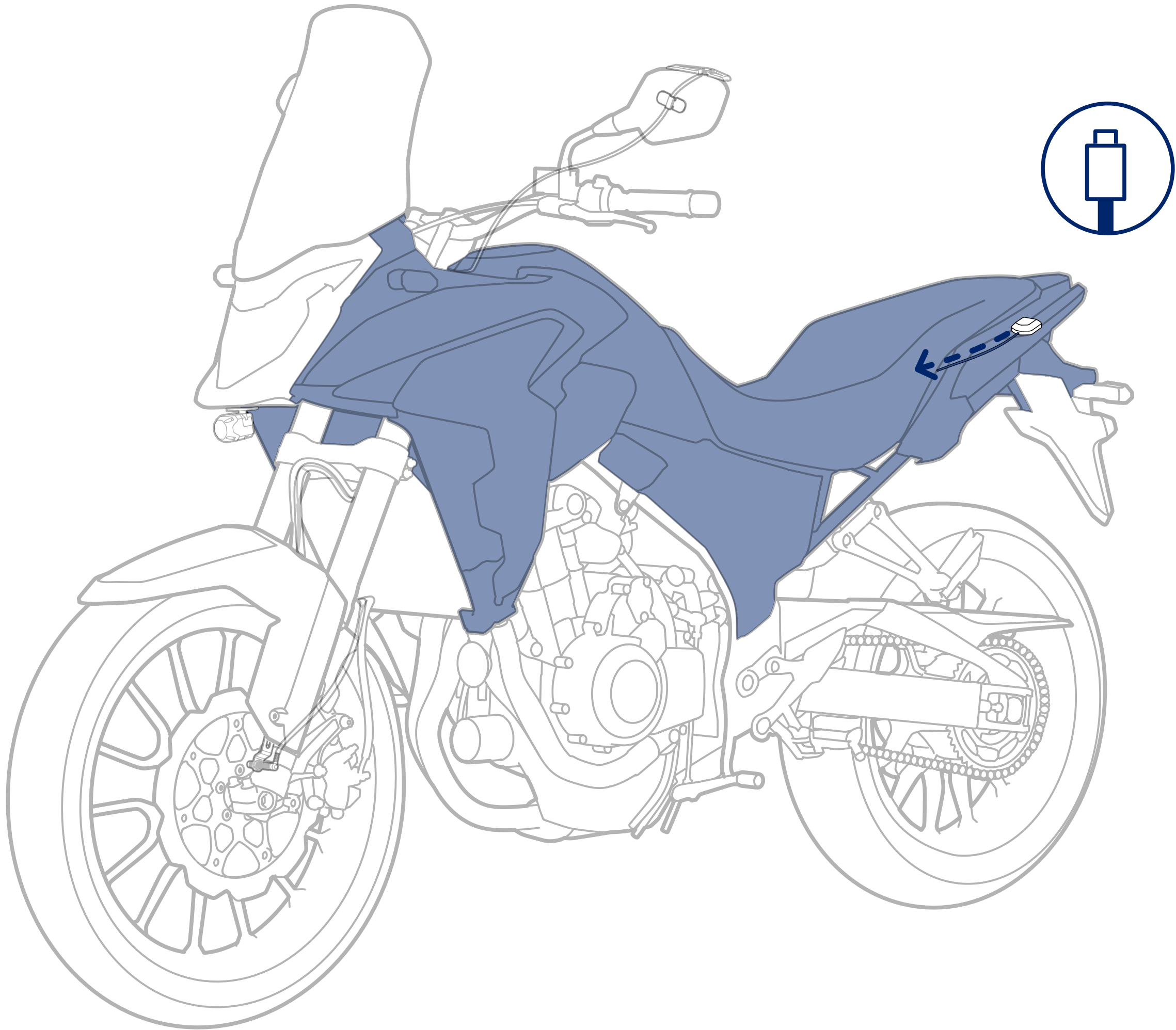

8



Find location

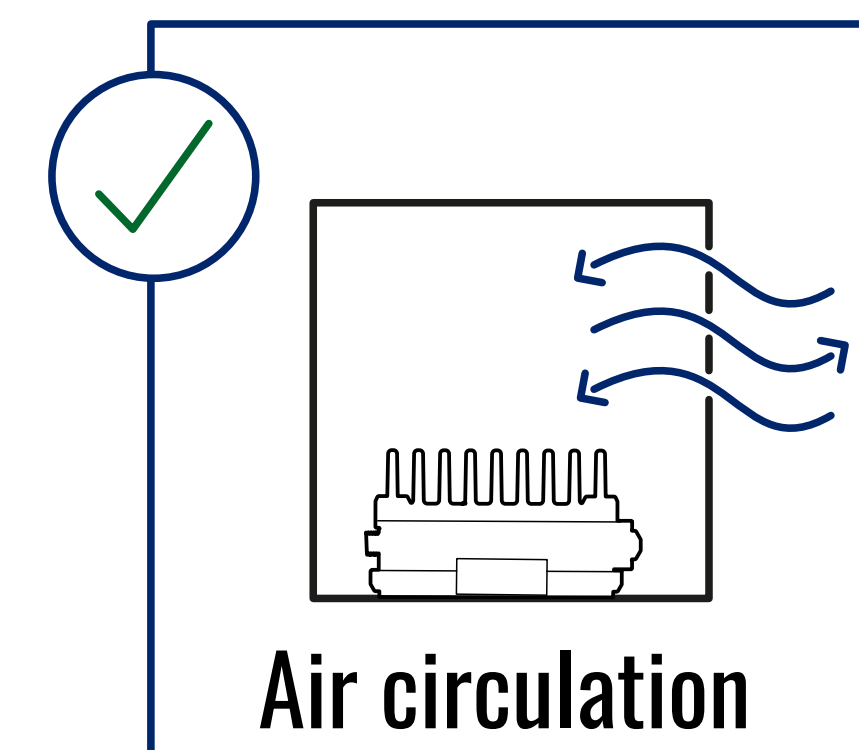
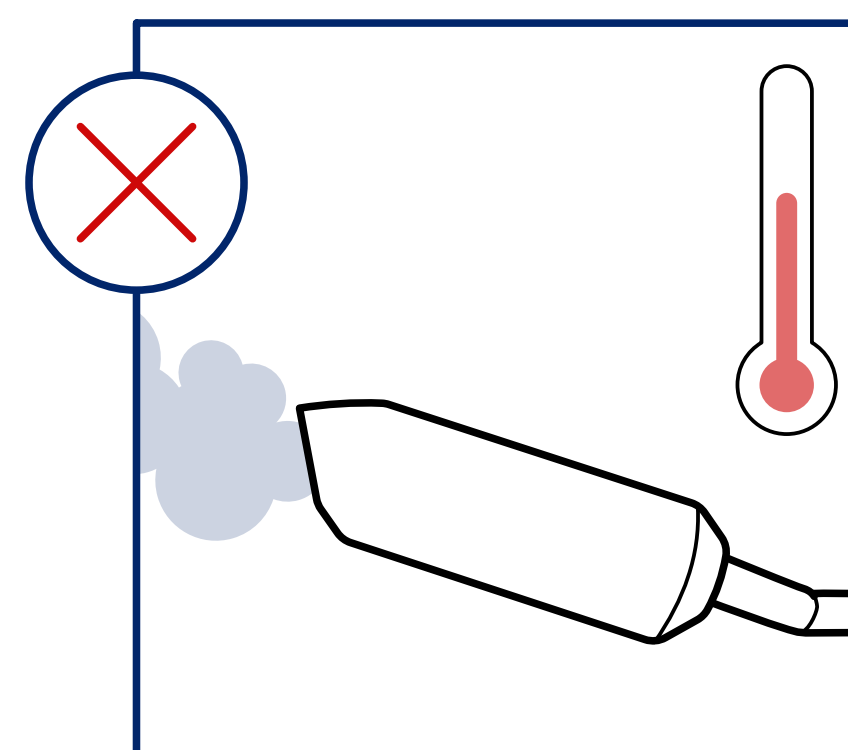
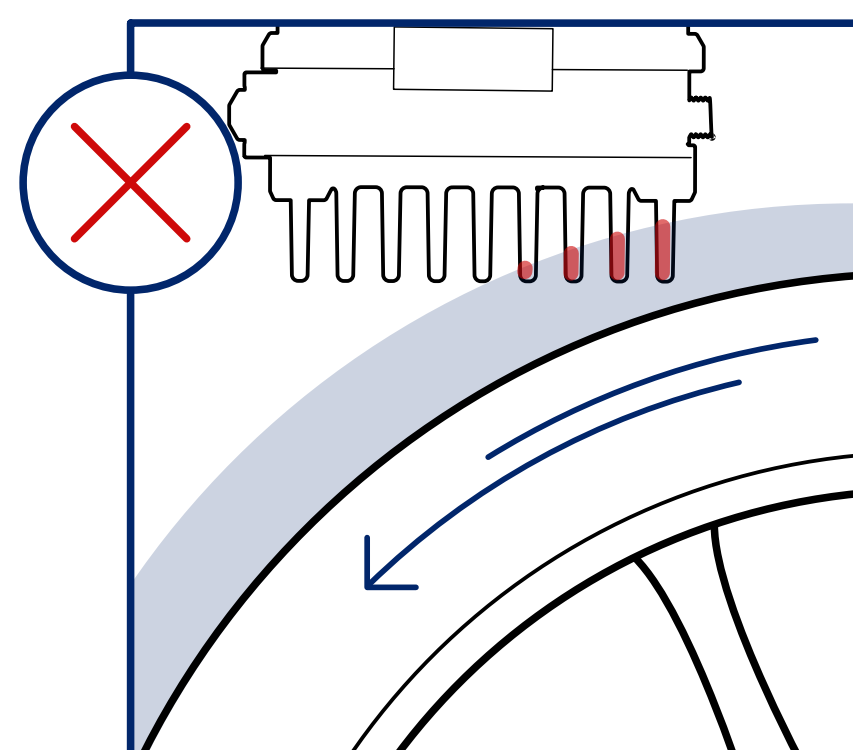
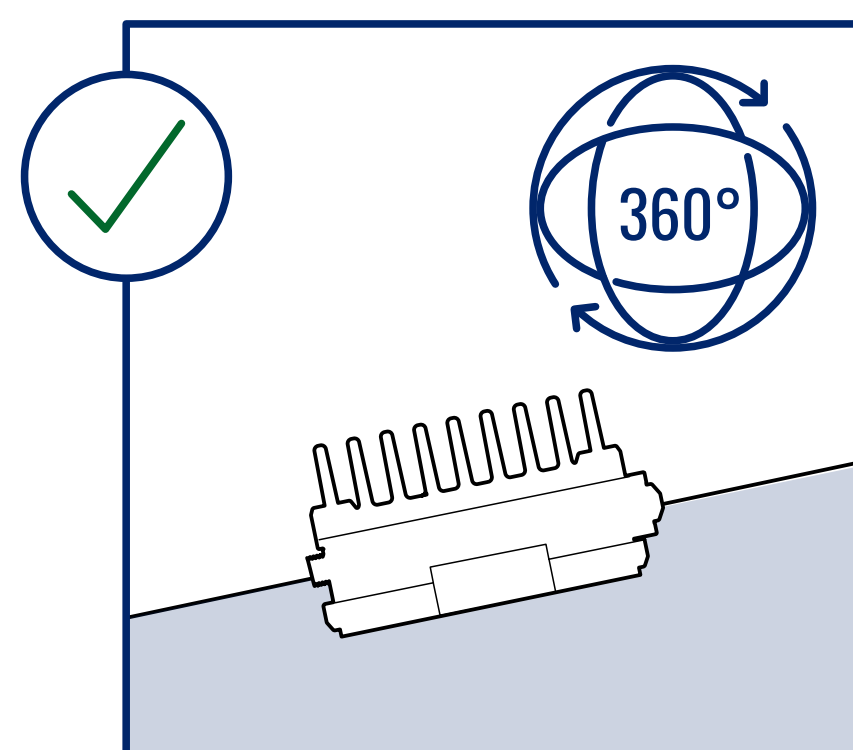
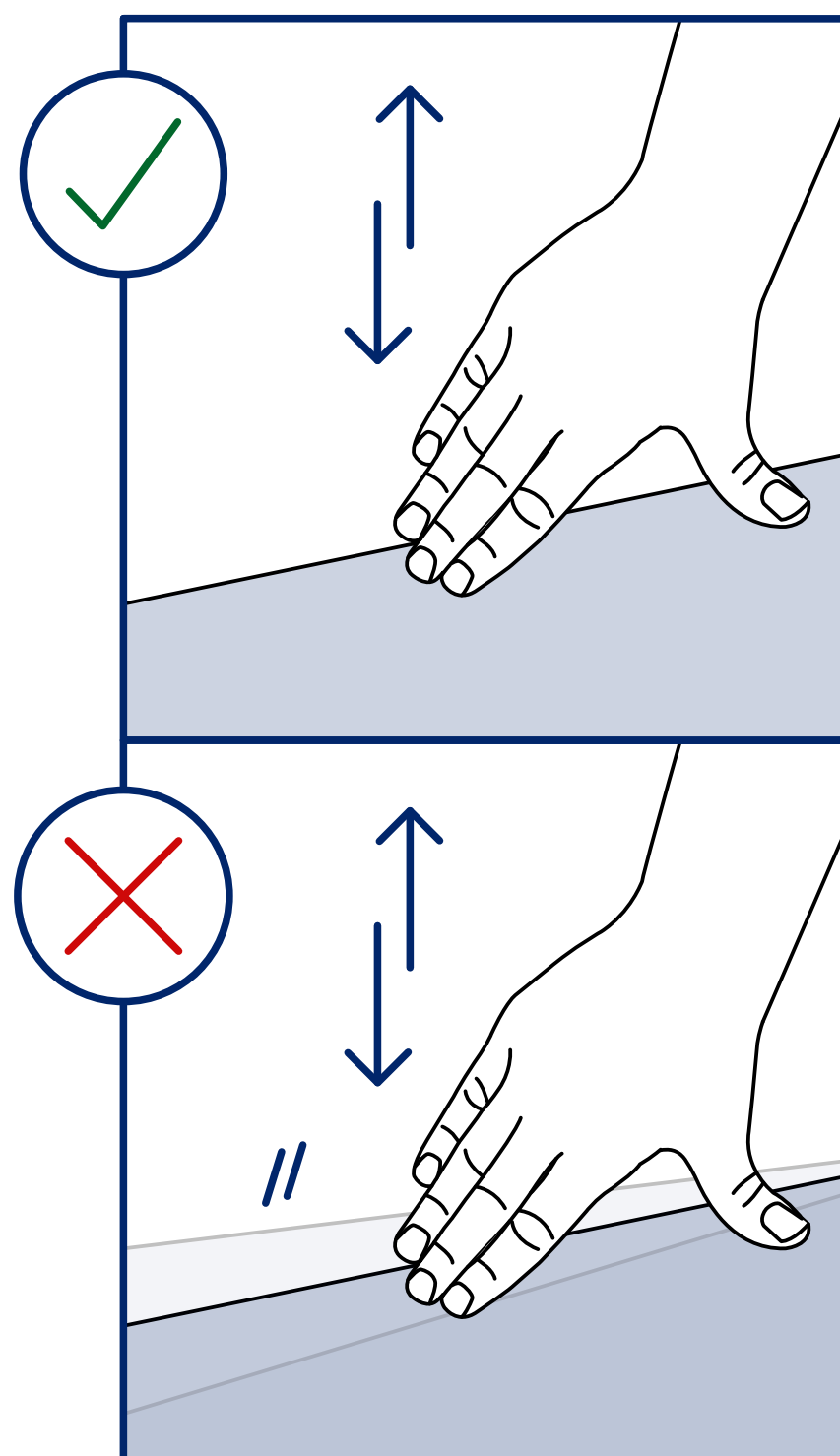
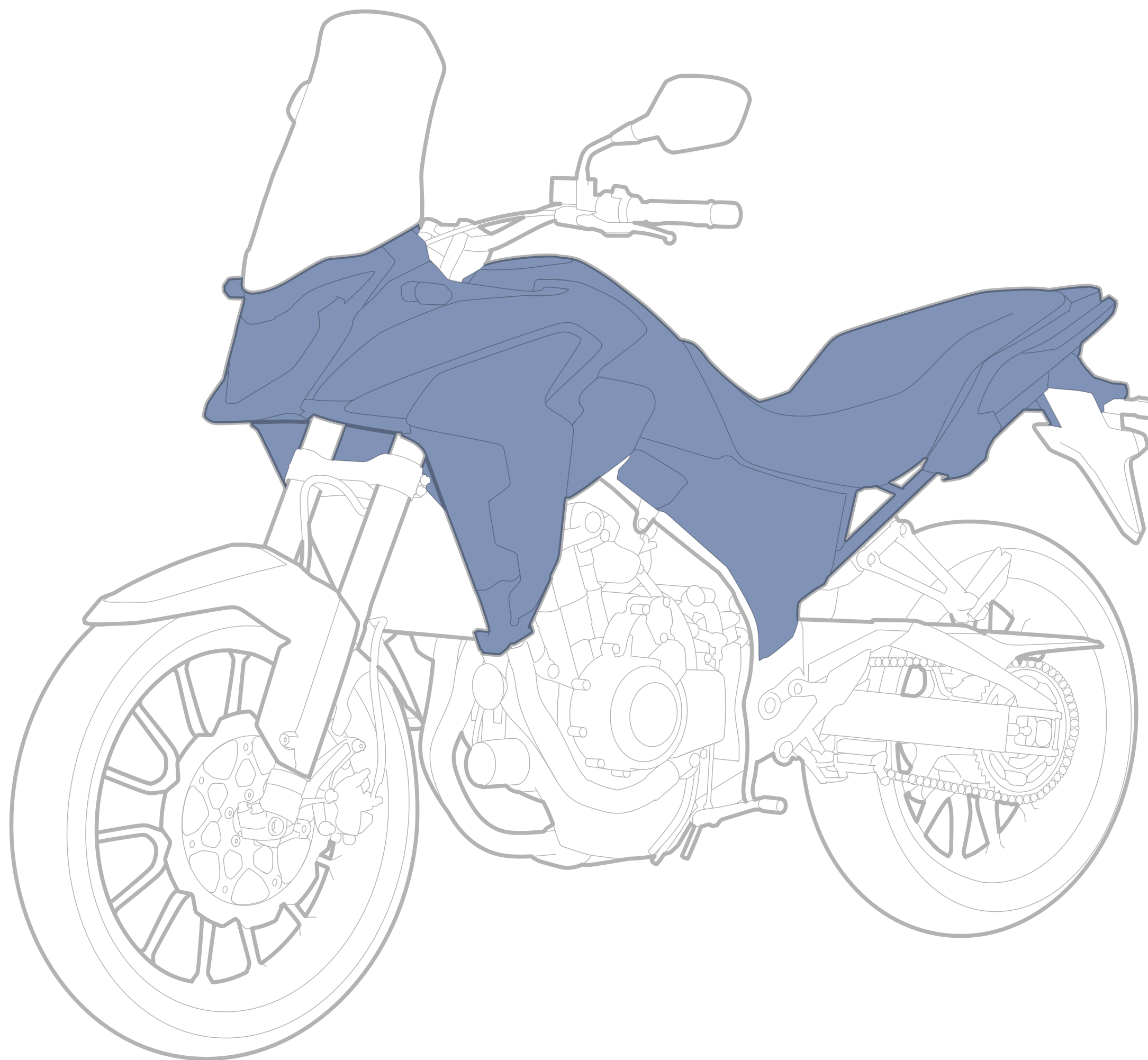
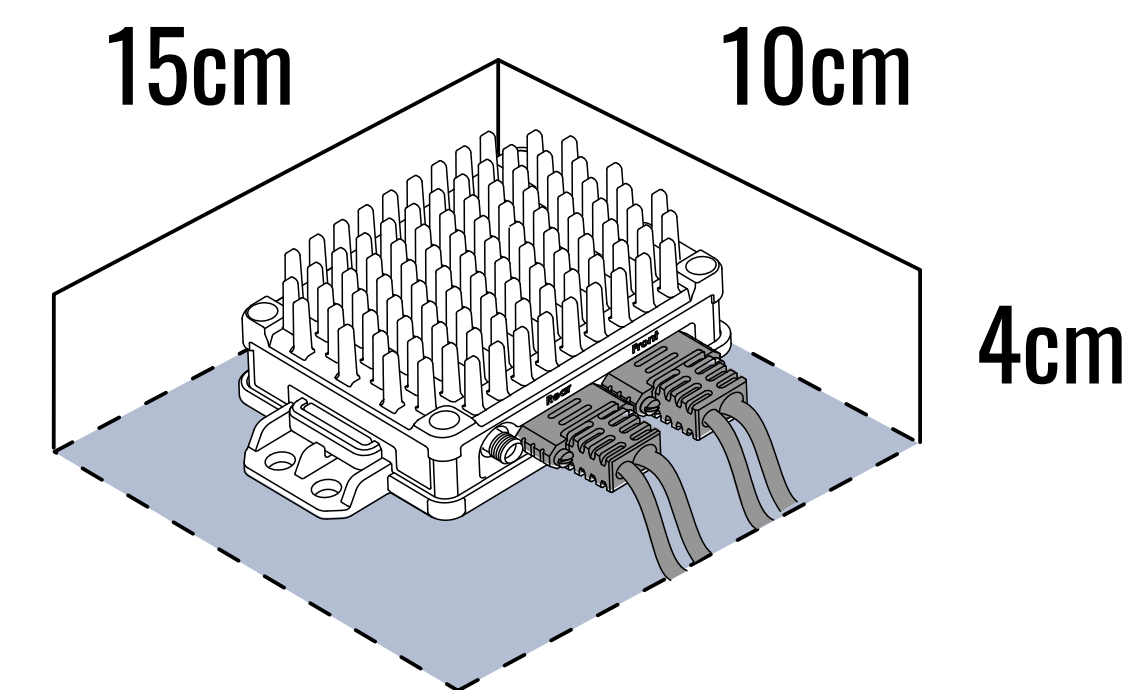
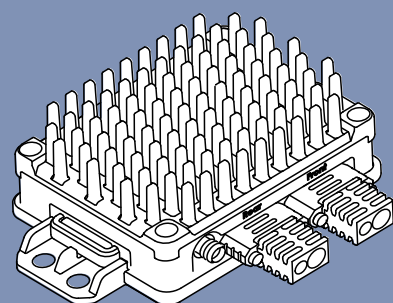

8

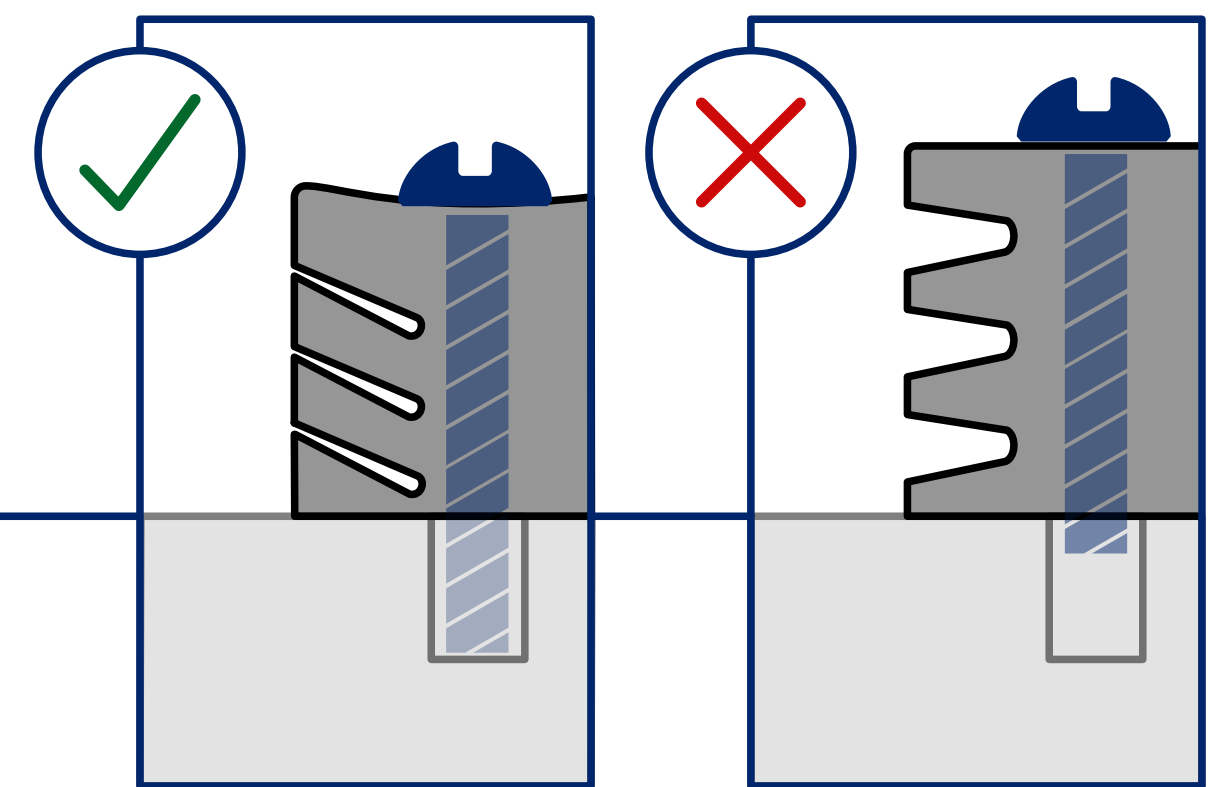
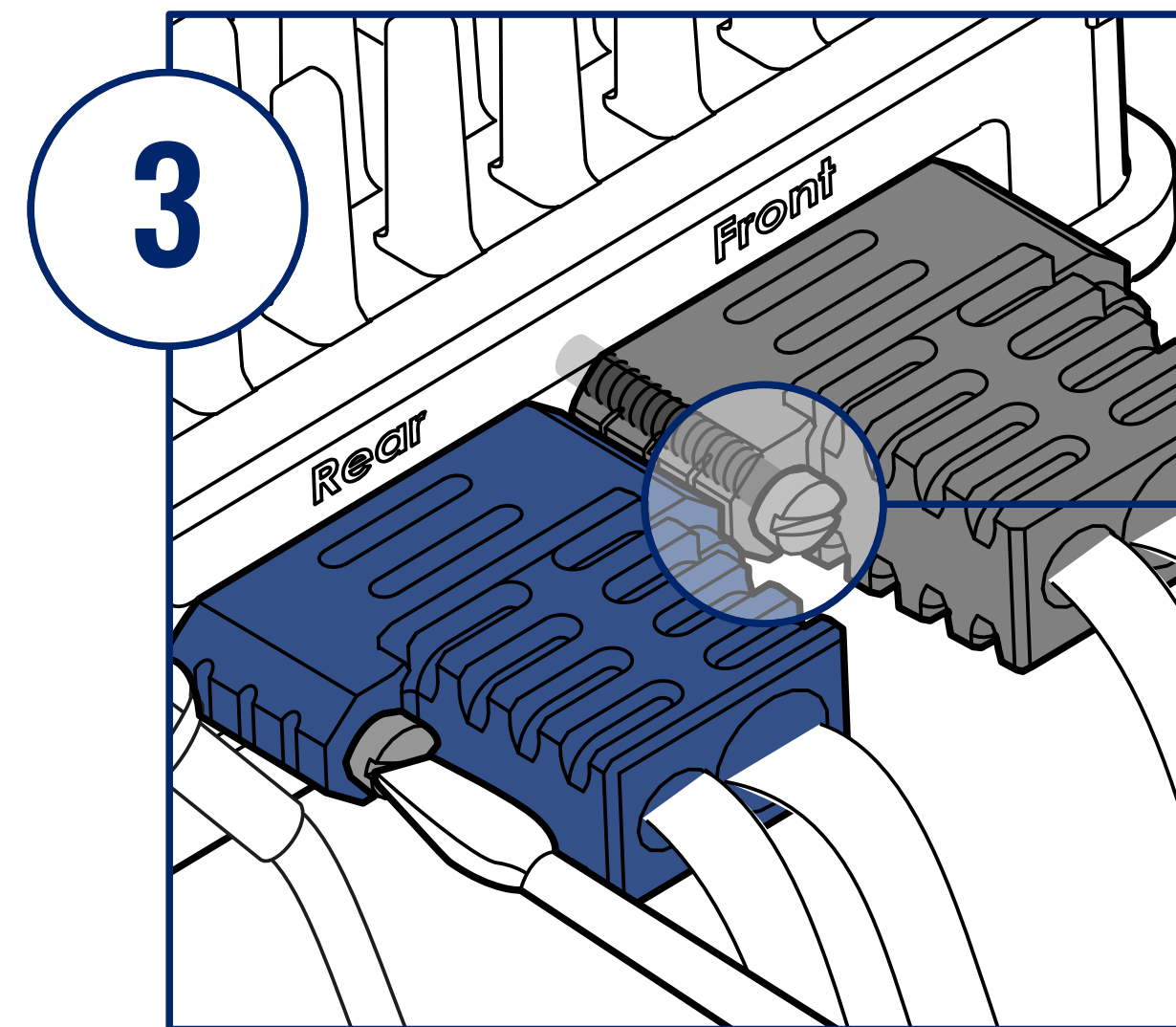
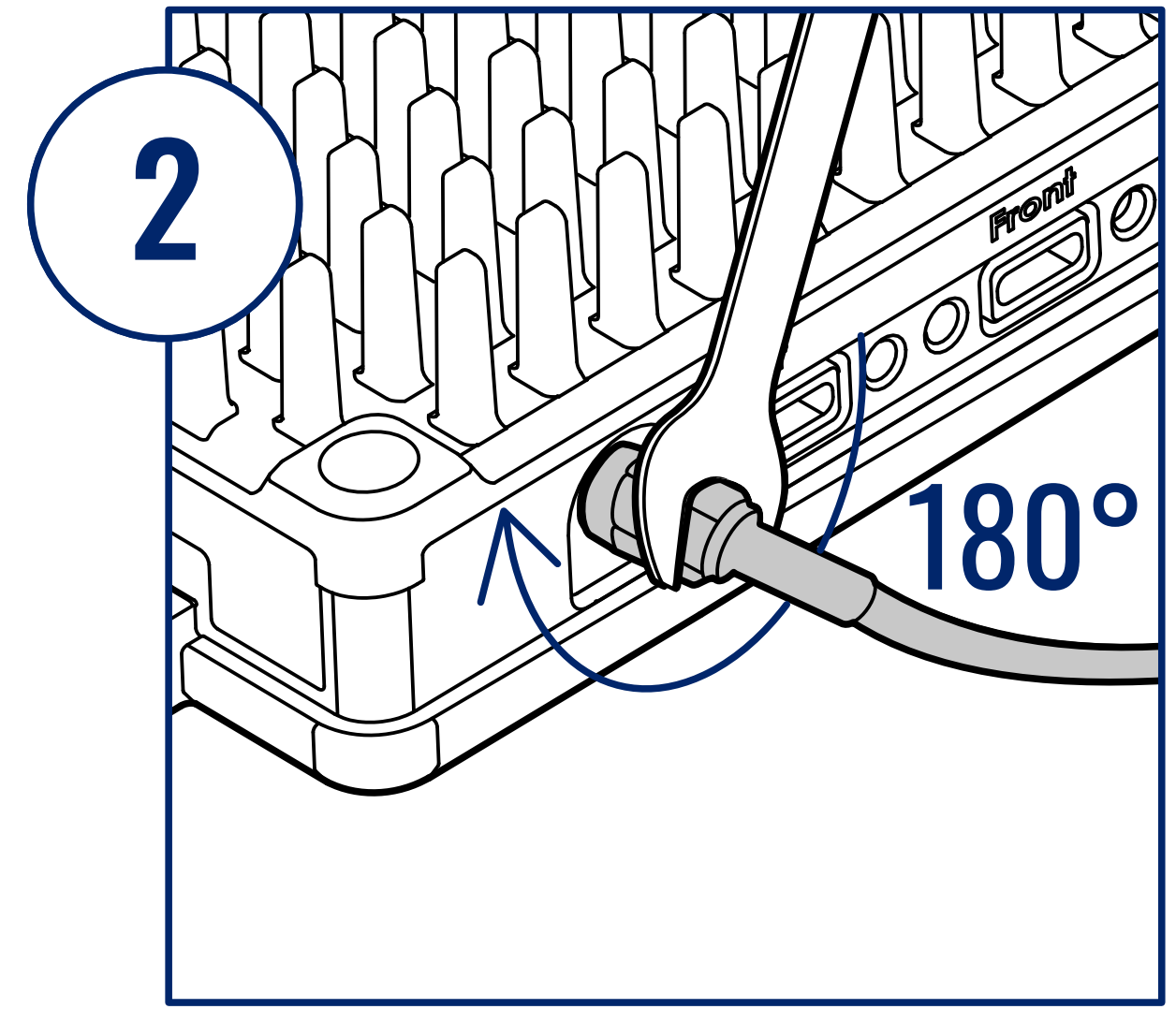
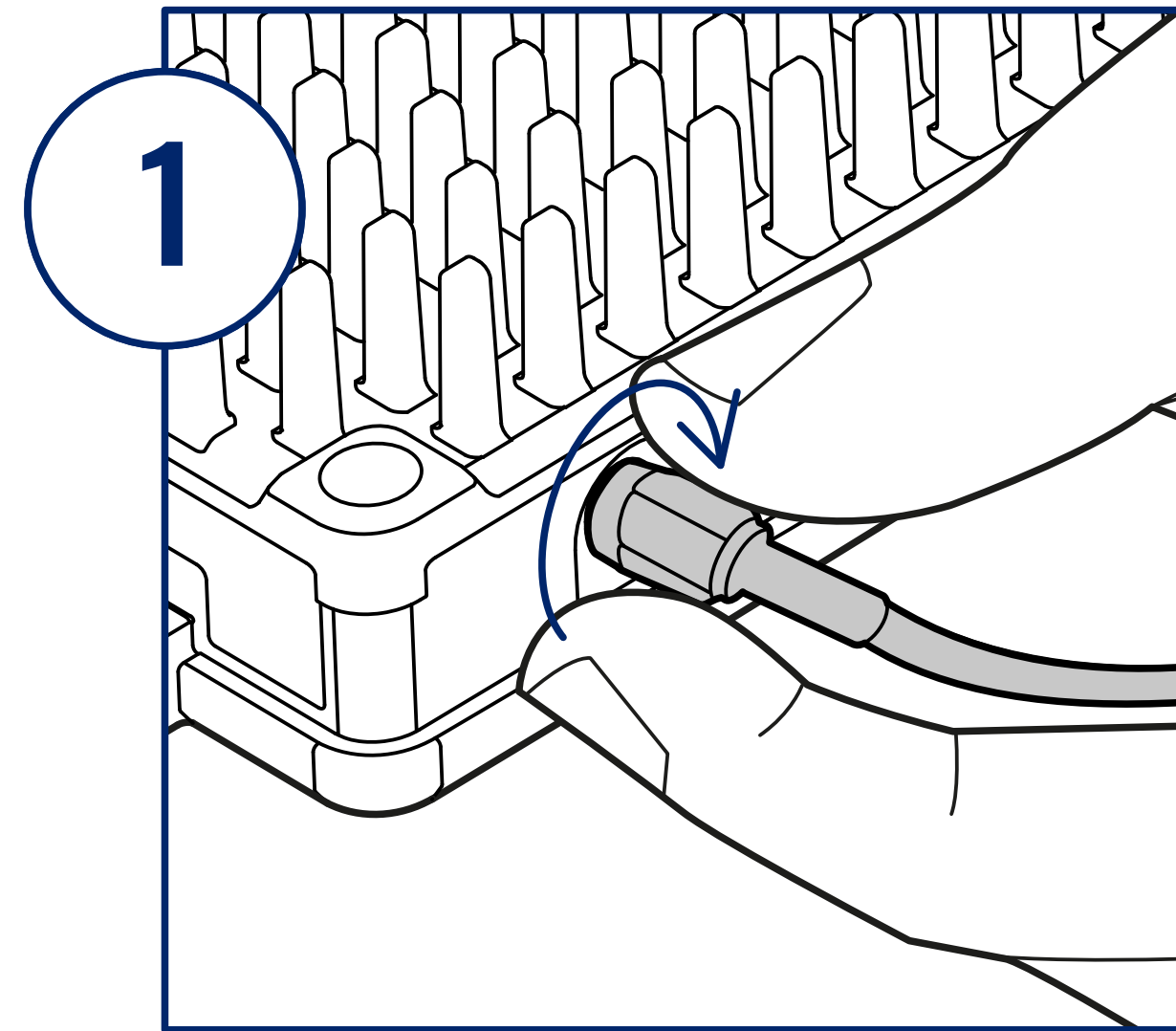
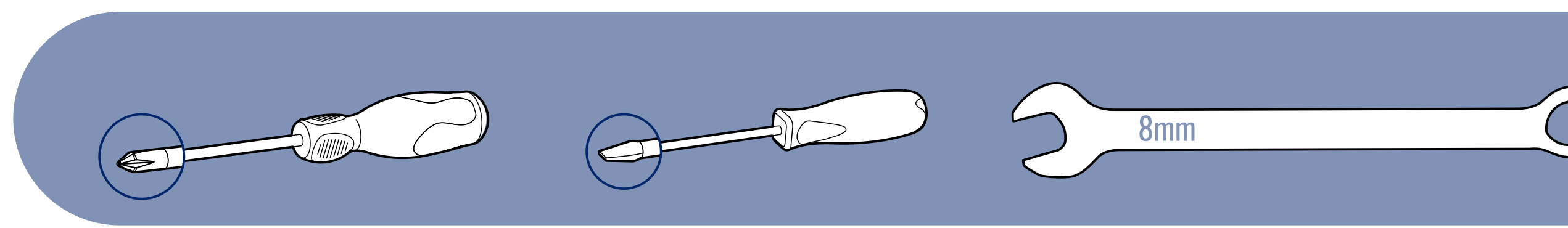
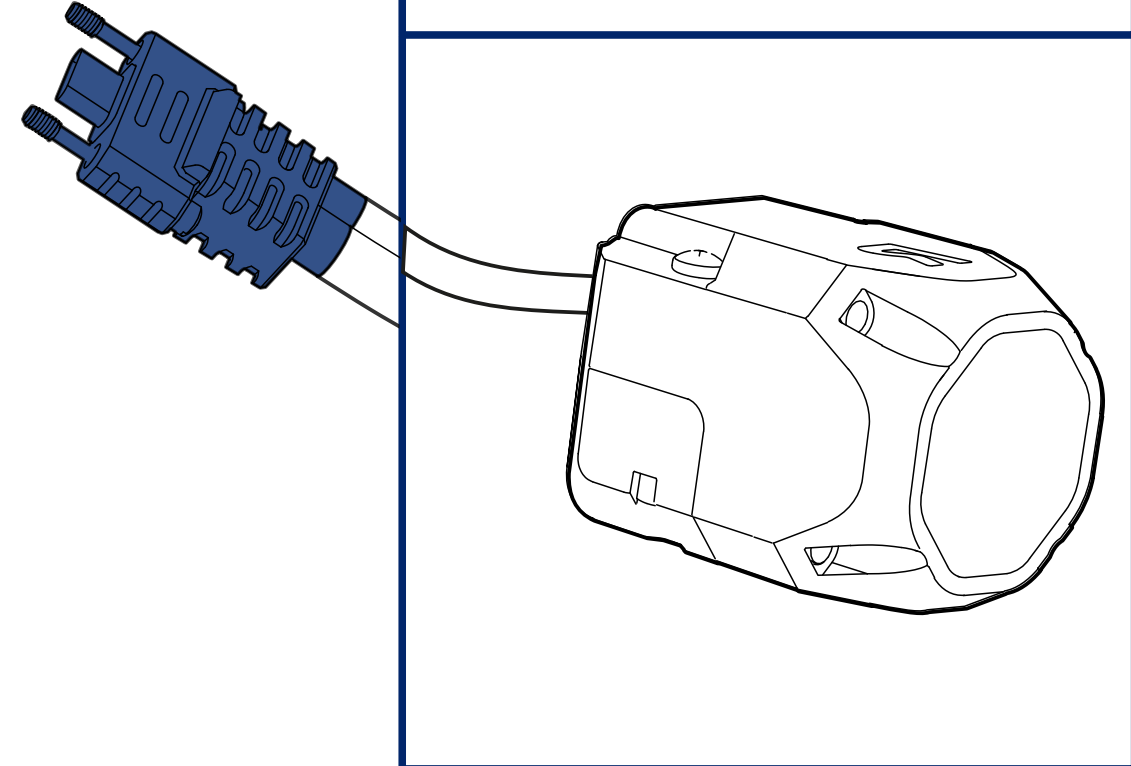
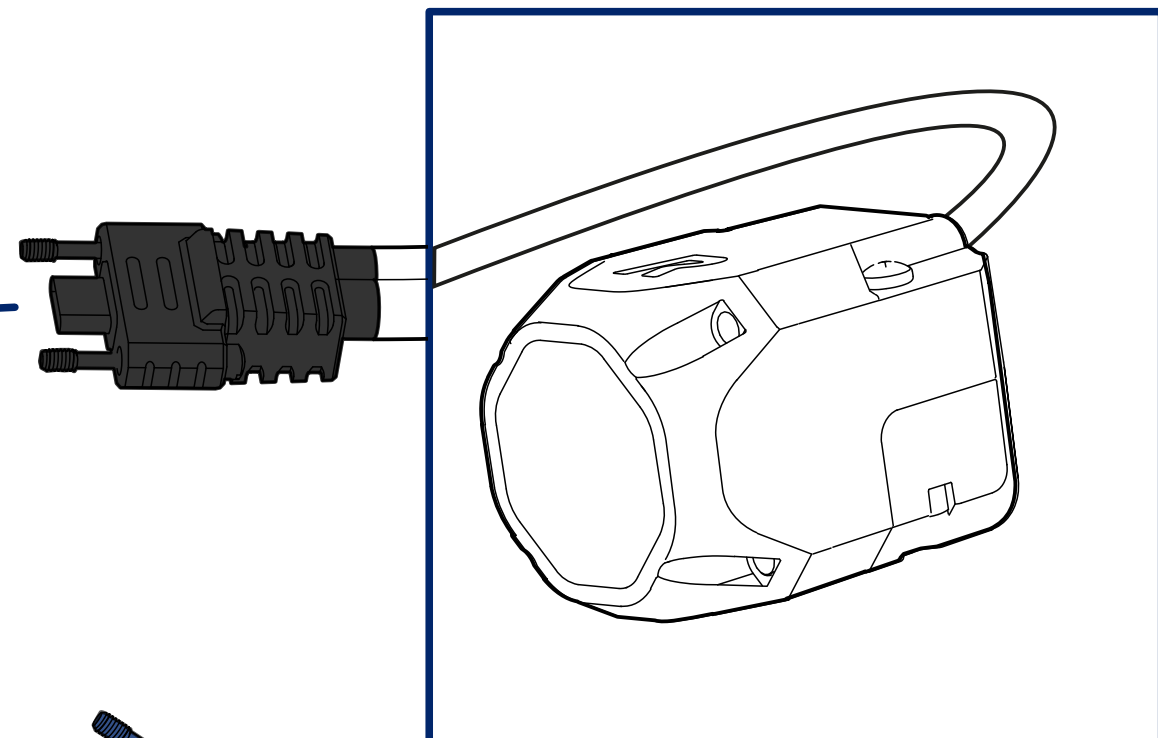
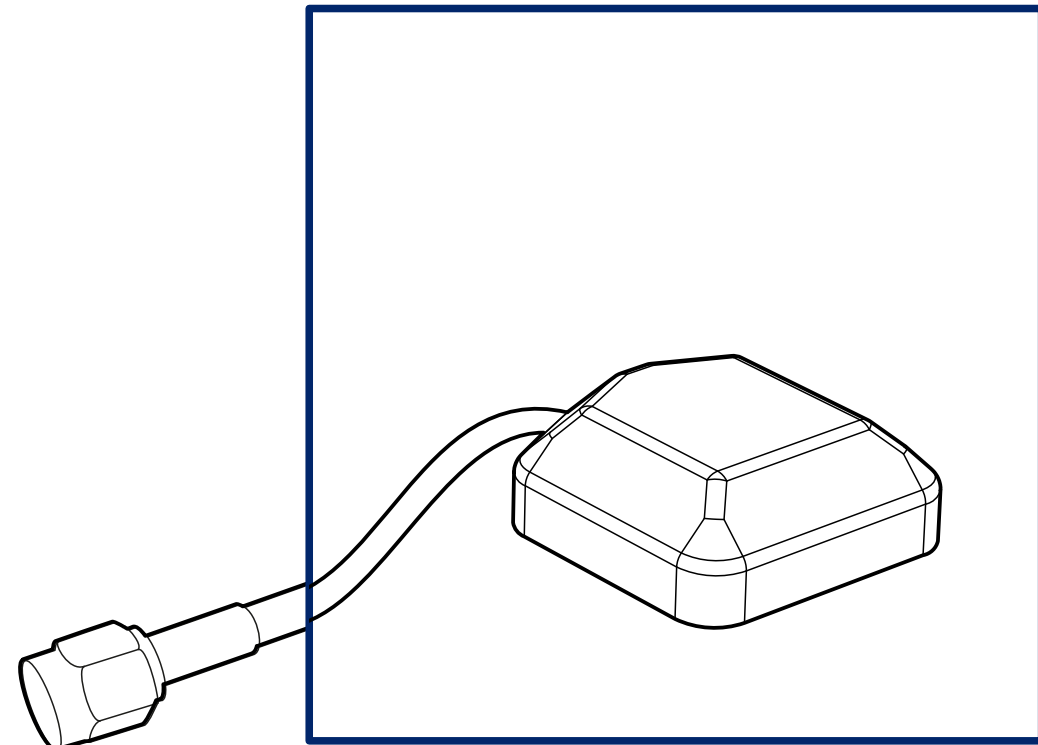
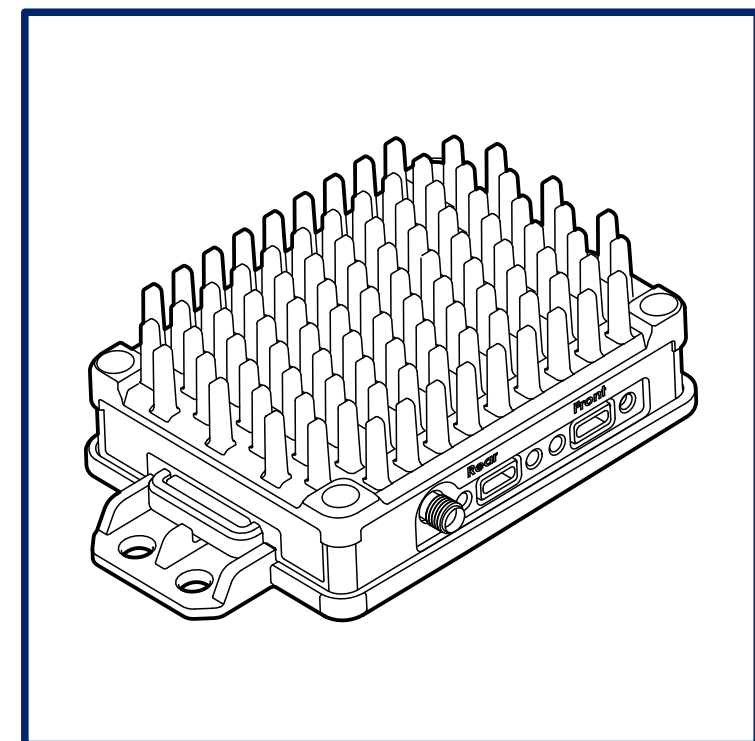
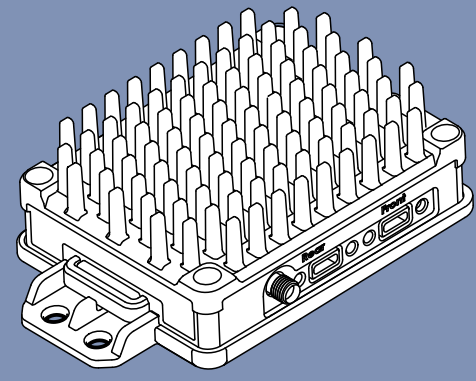

! Screw the bolt until it can't move

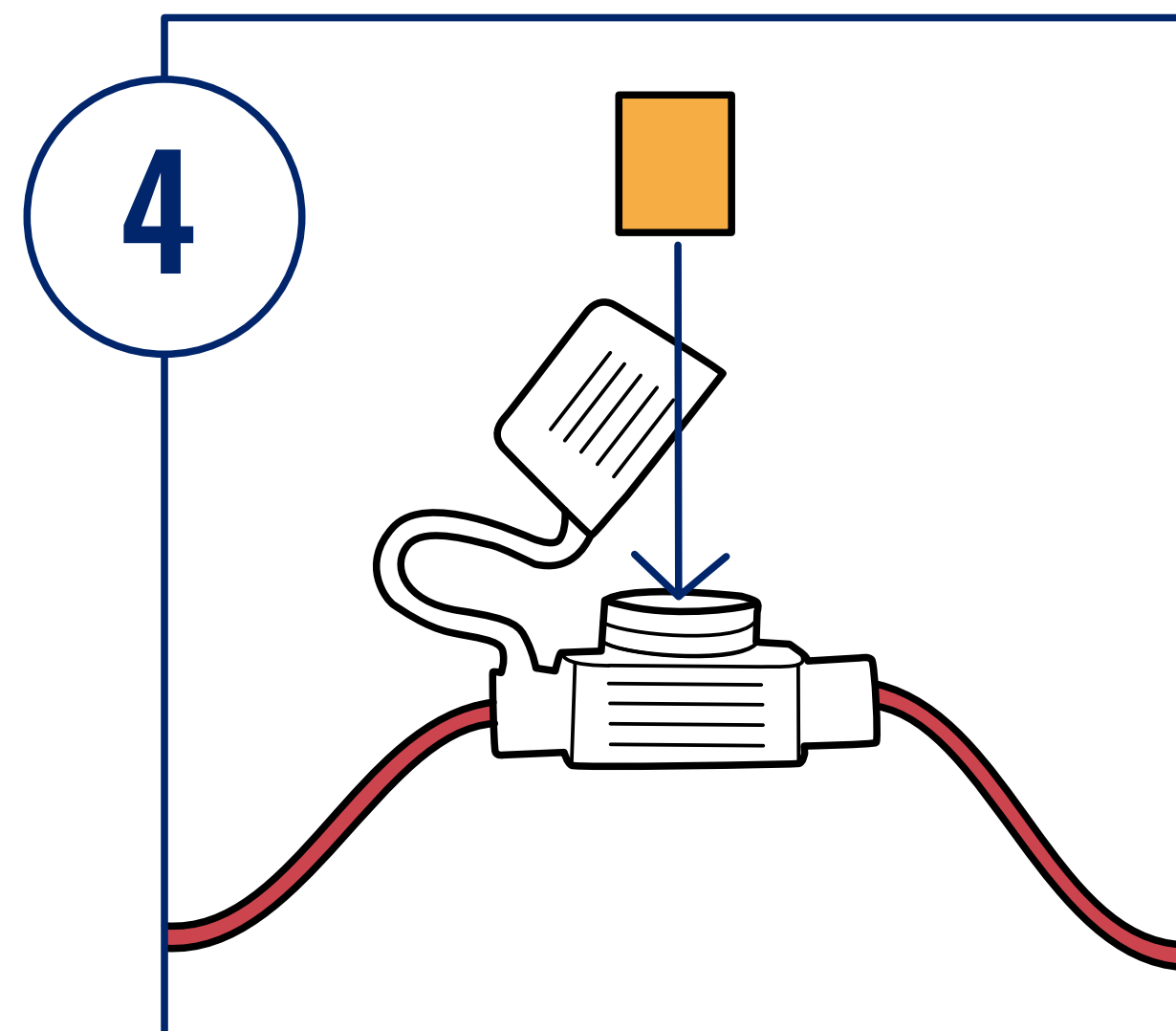

8

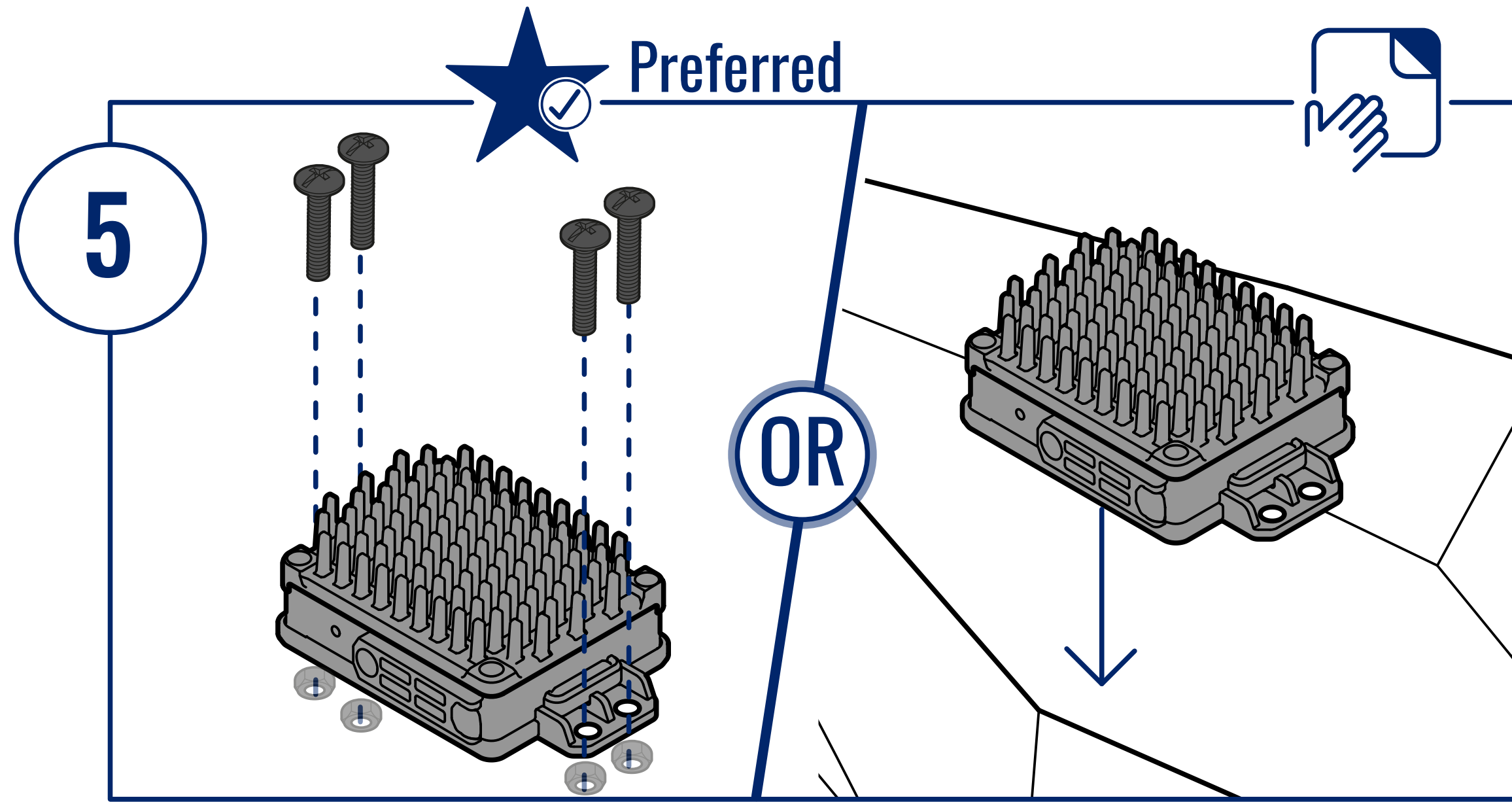
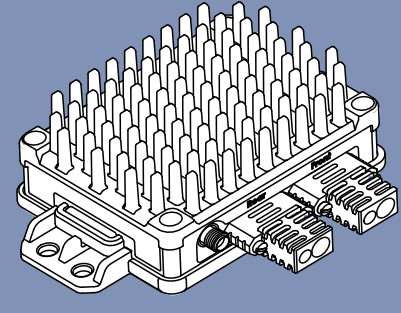

When unit is mounted on an external surface - Using screws is mandatory

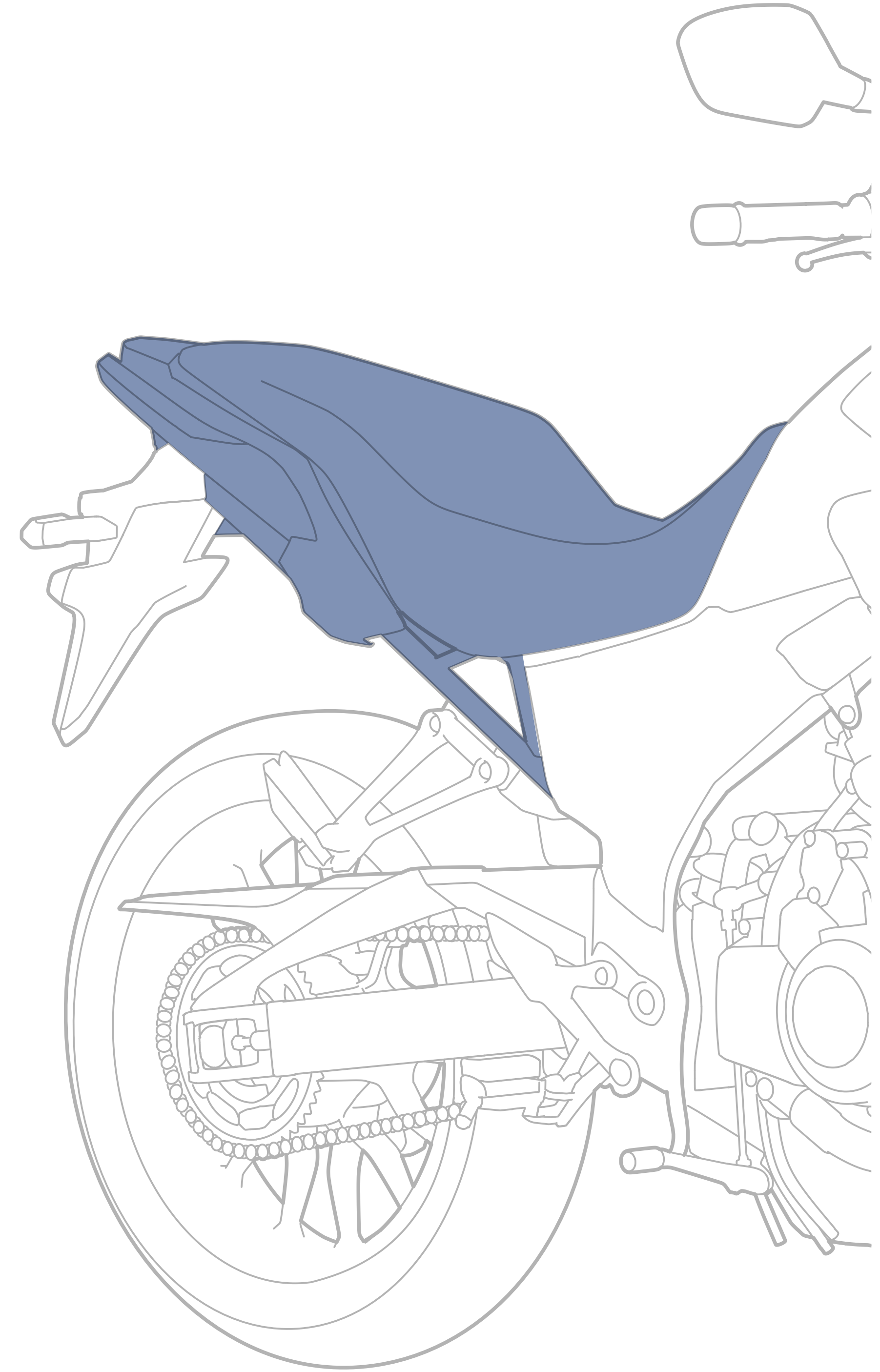

9

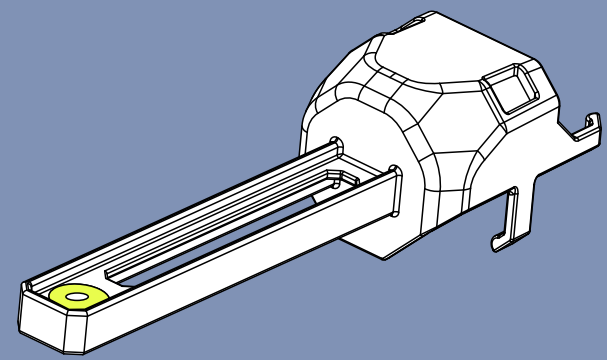

Rear and Front

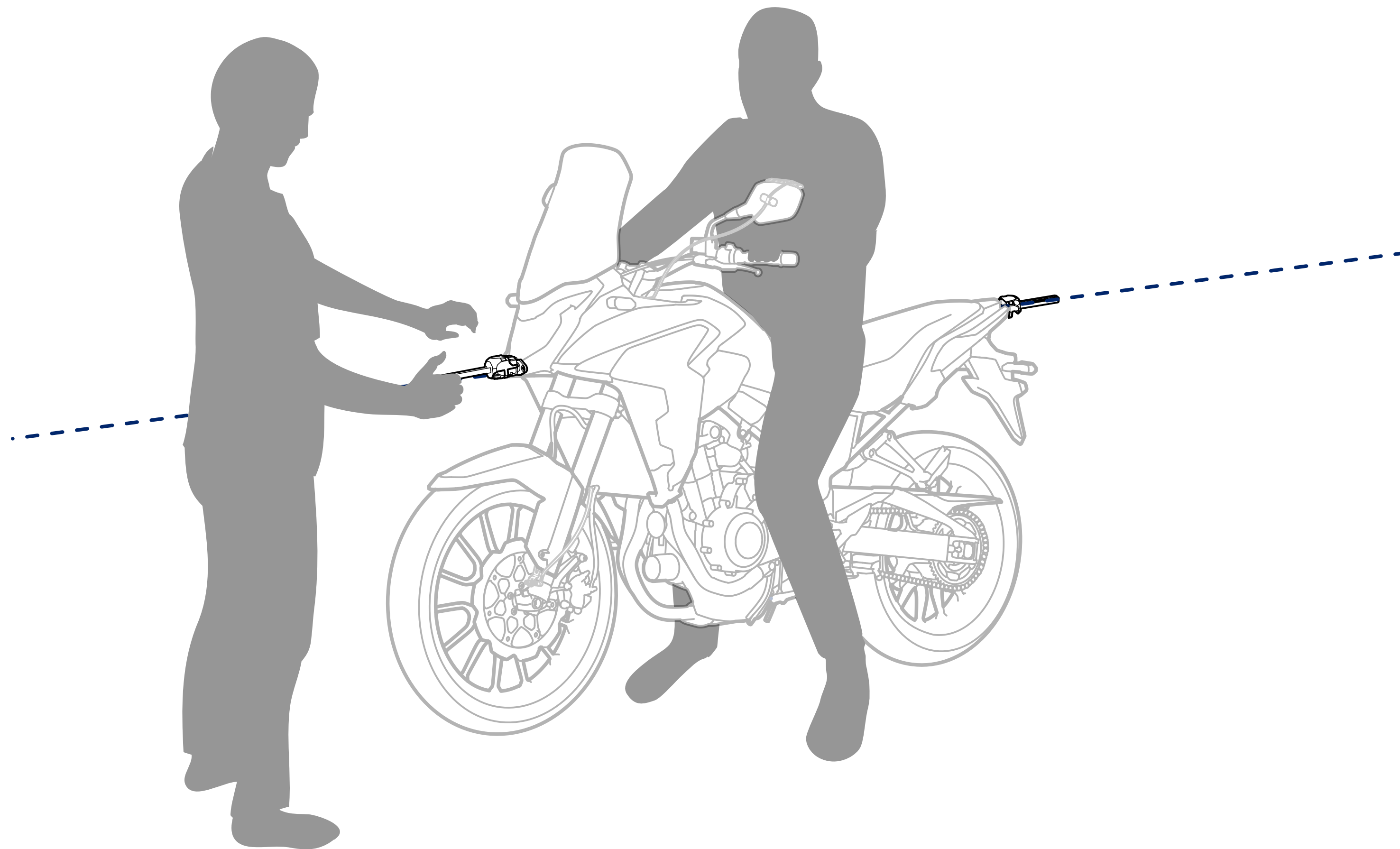
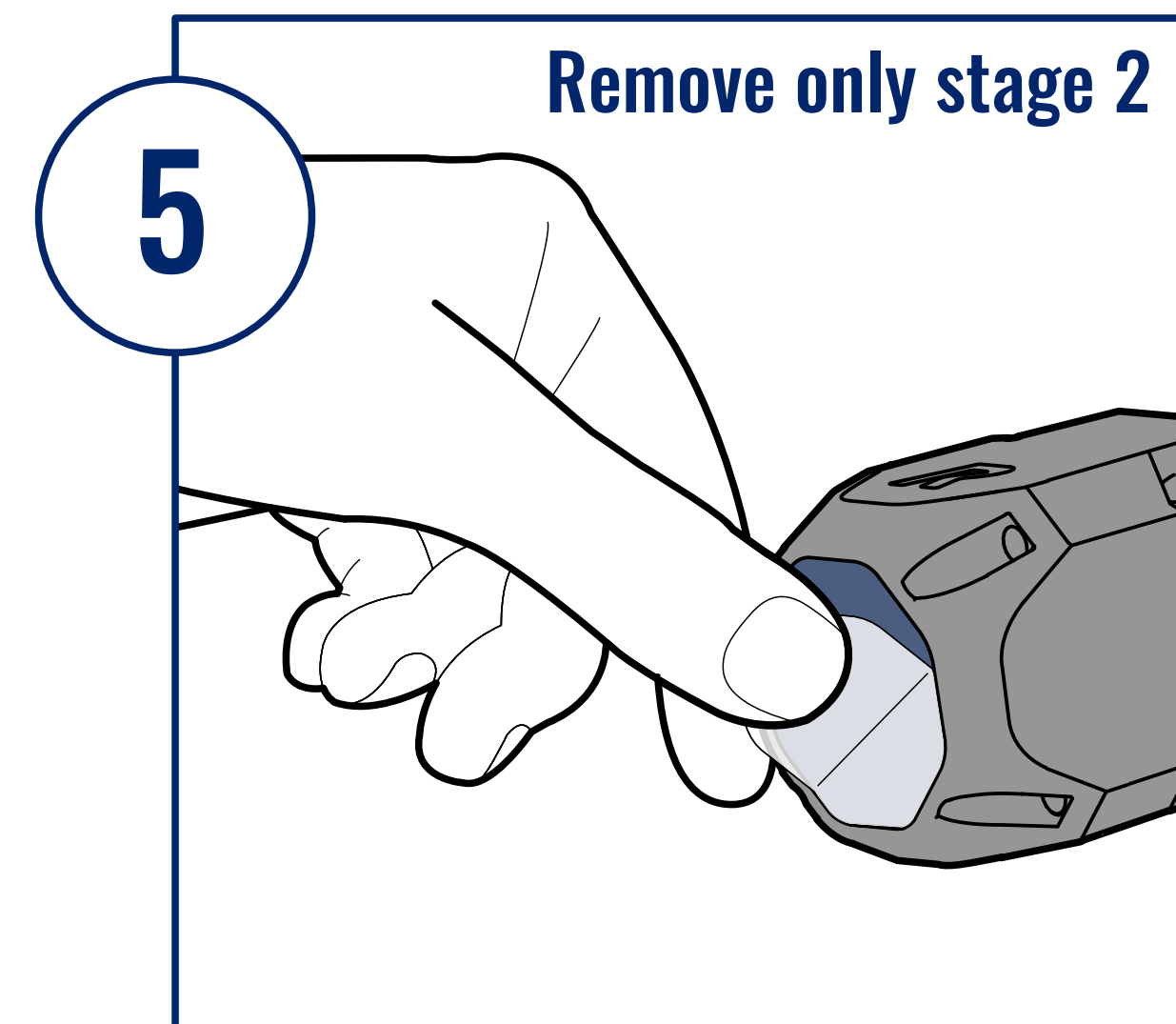
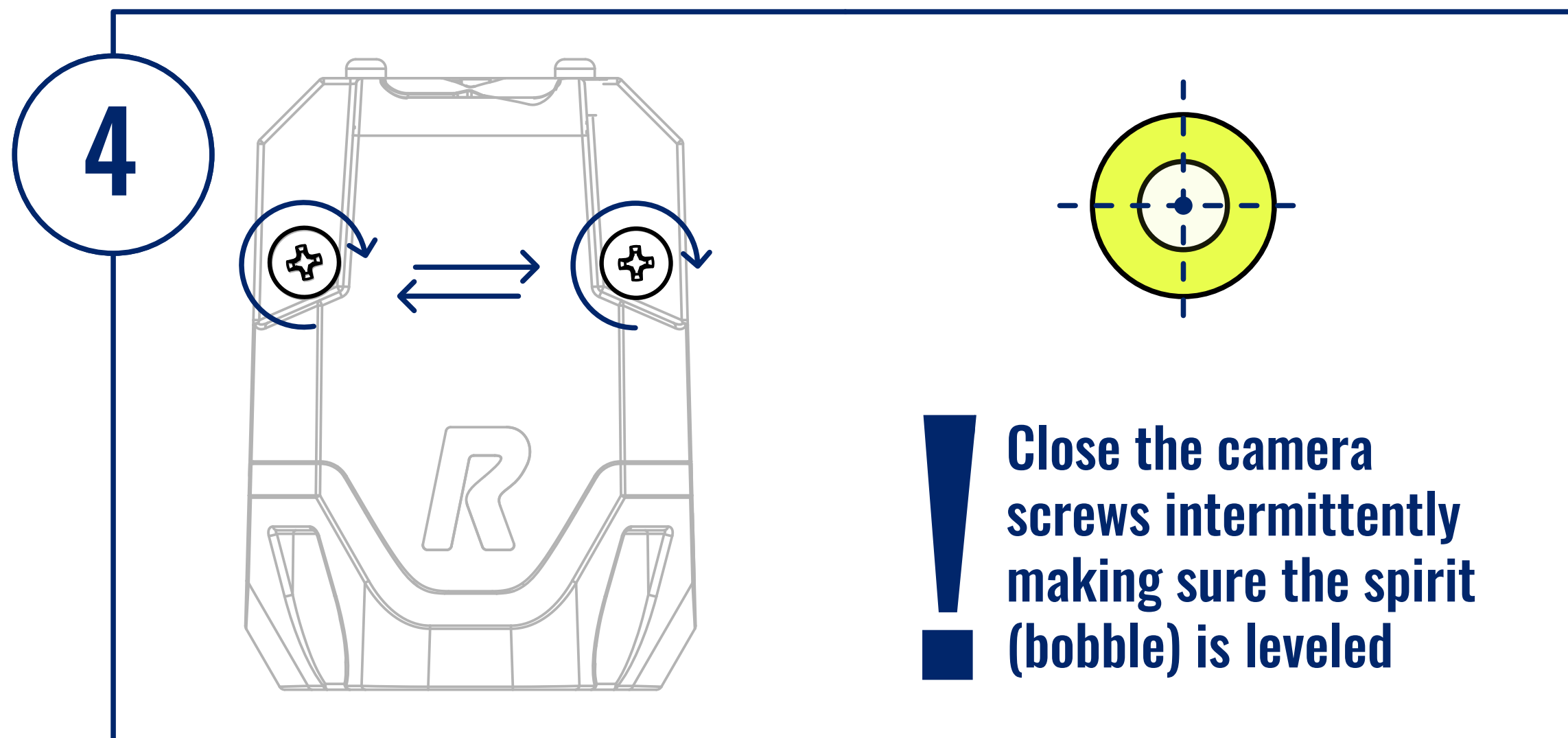
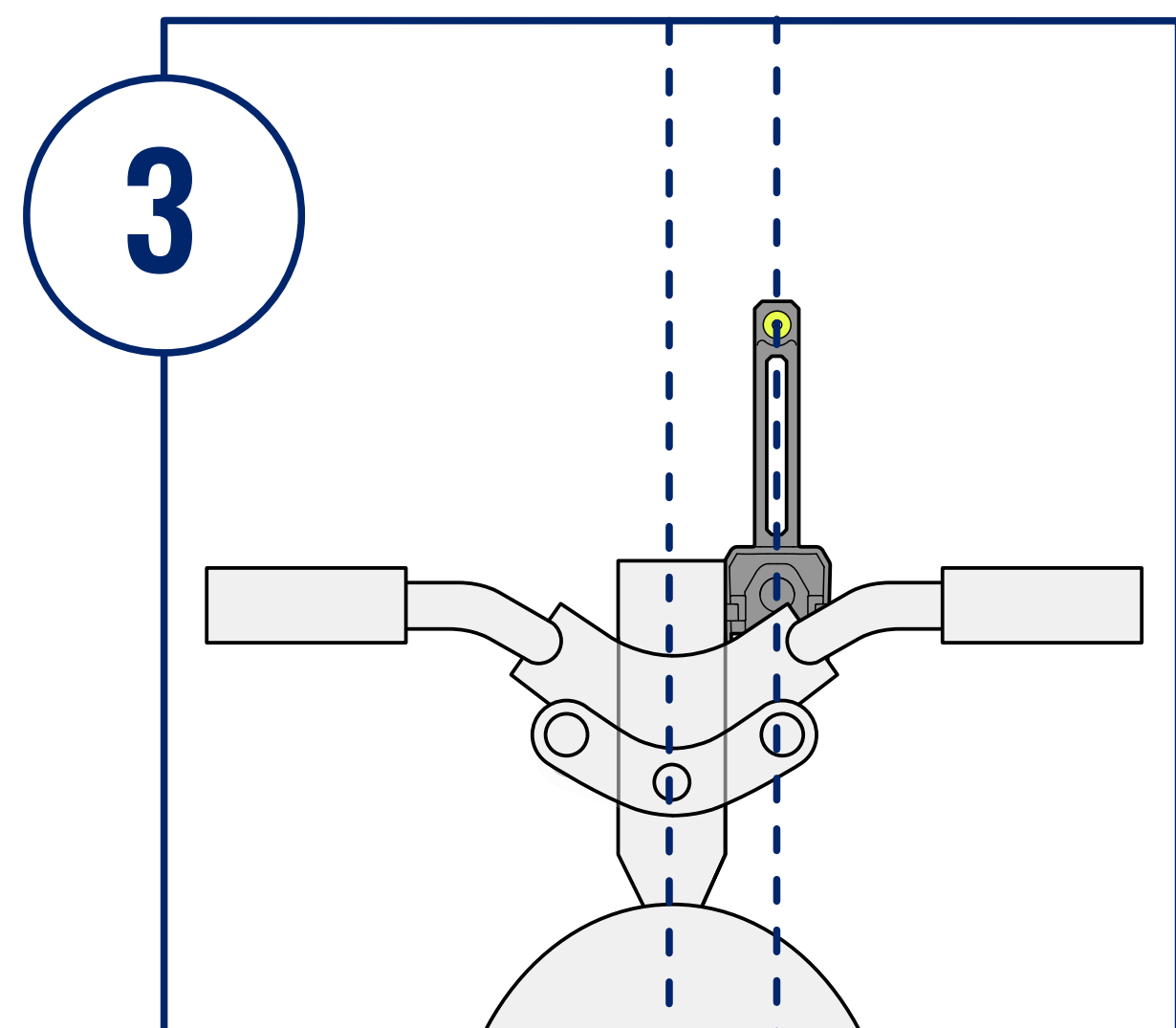
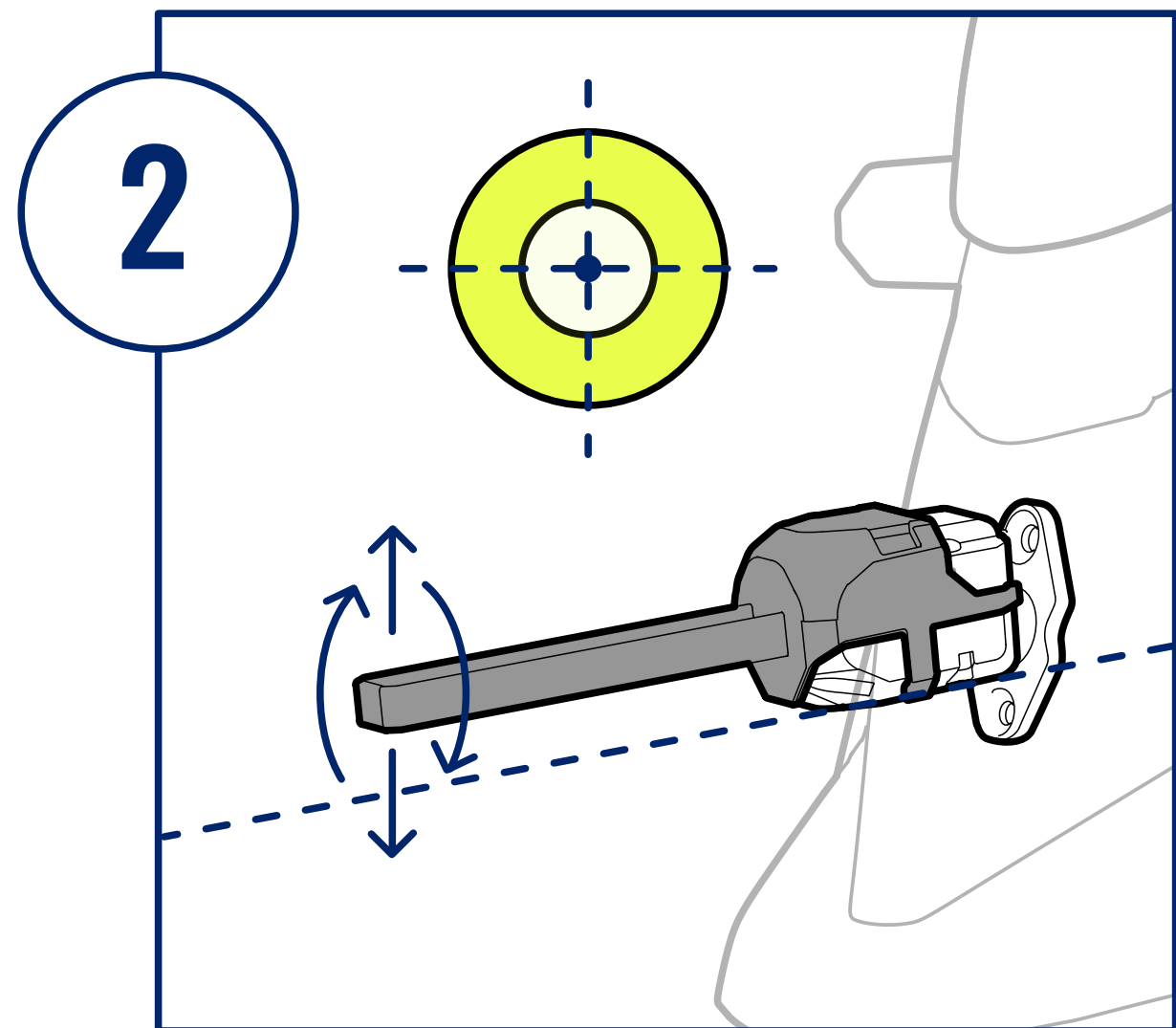
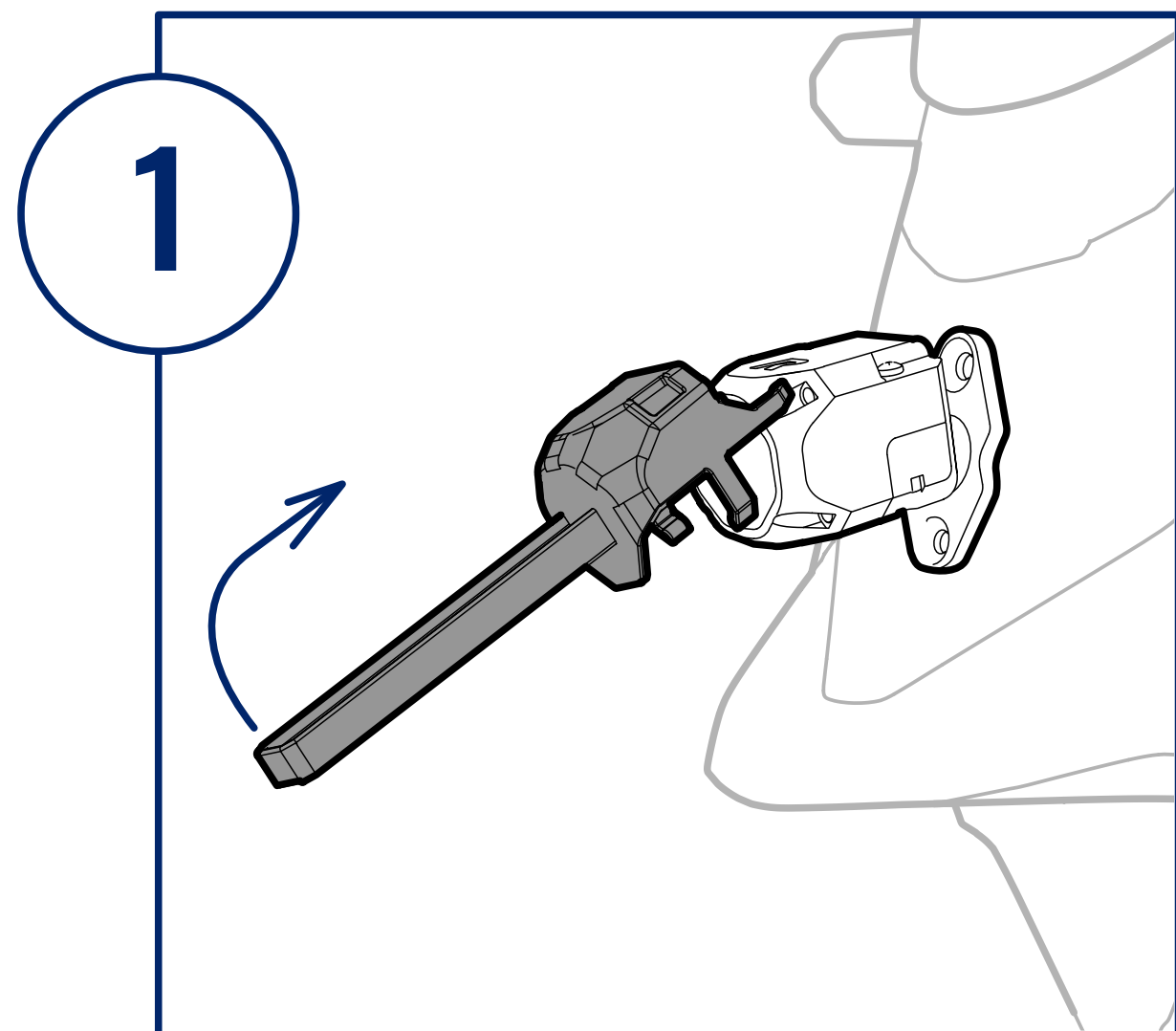
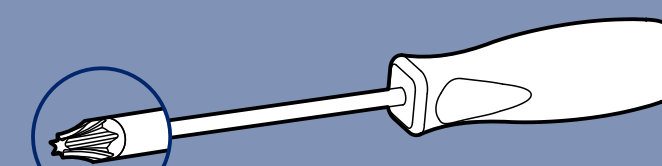

10

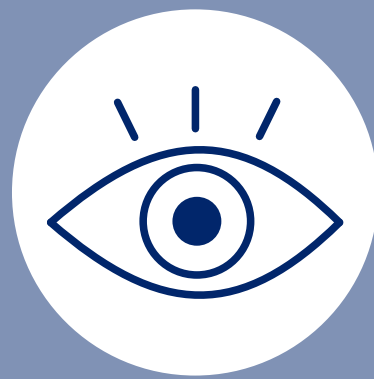

1

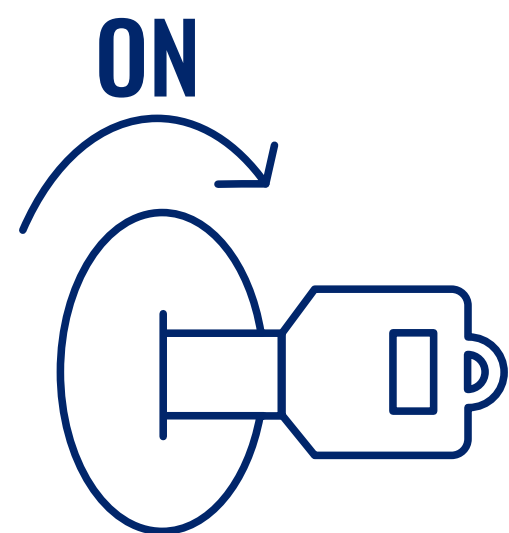

→ ≤ 15 SEC

2



x5

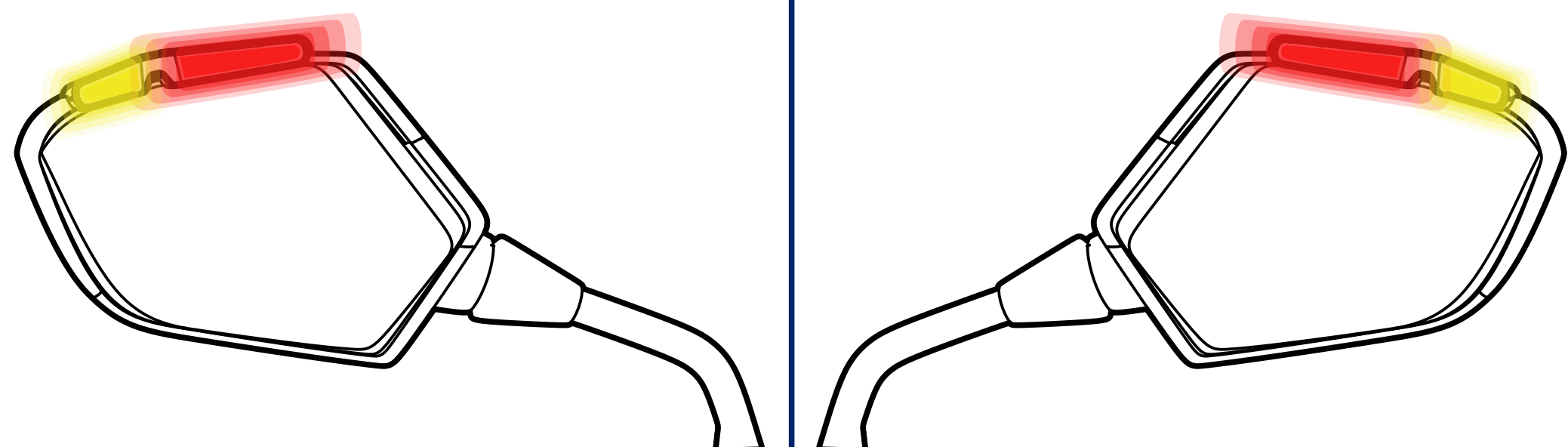

3

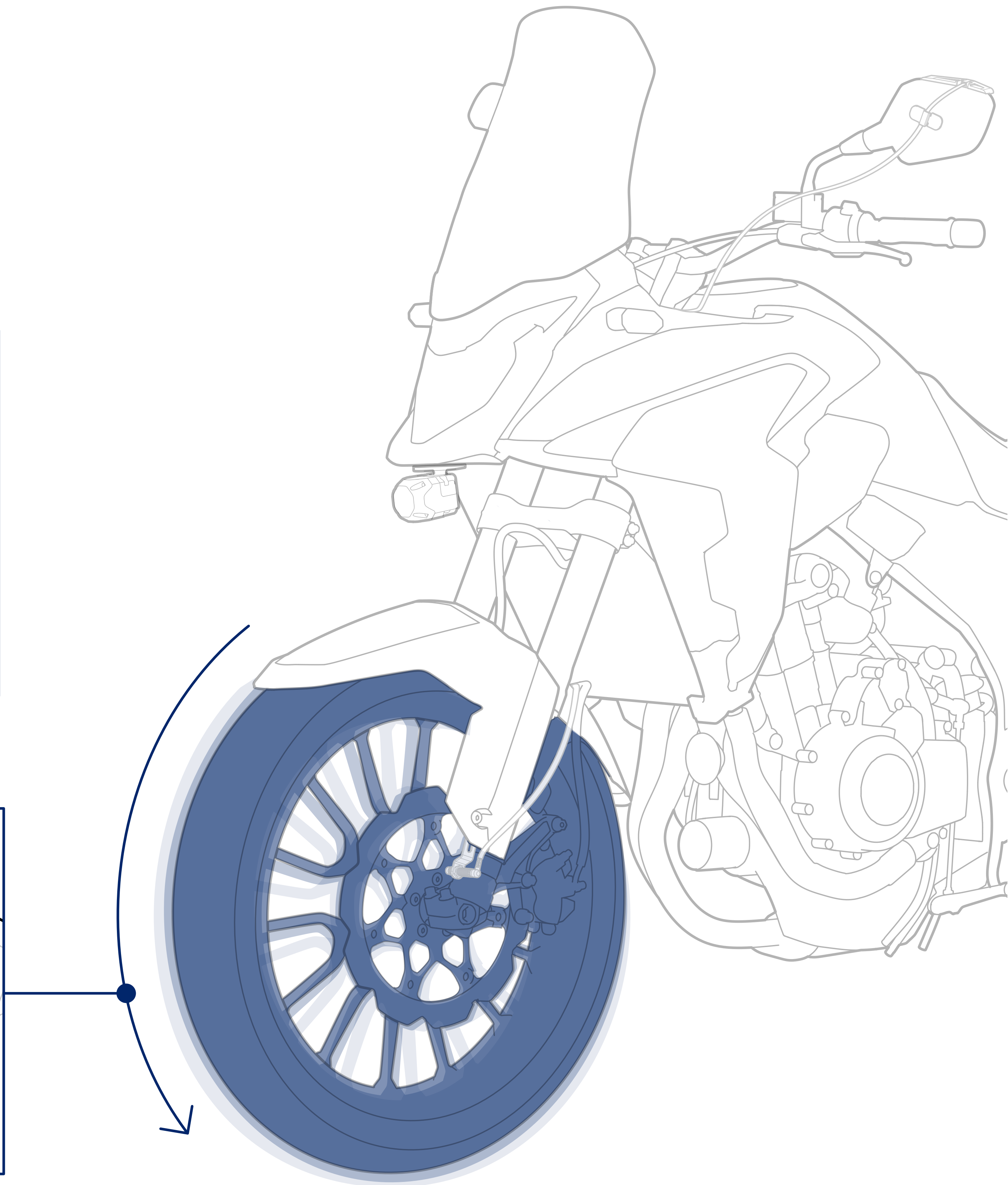
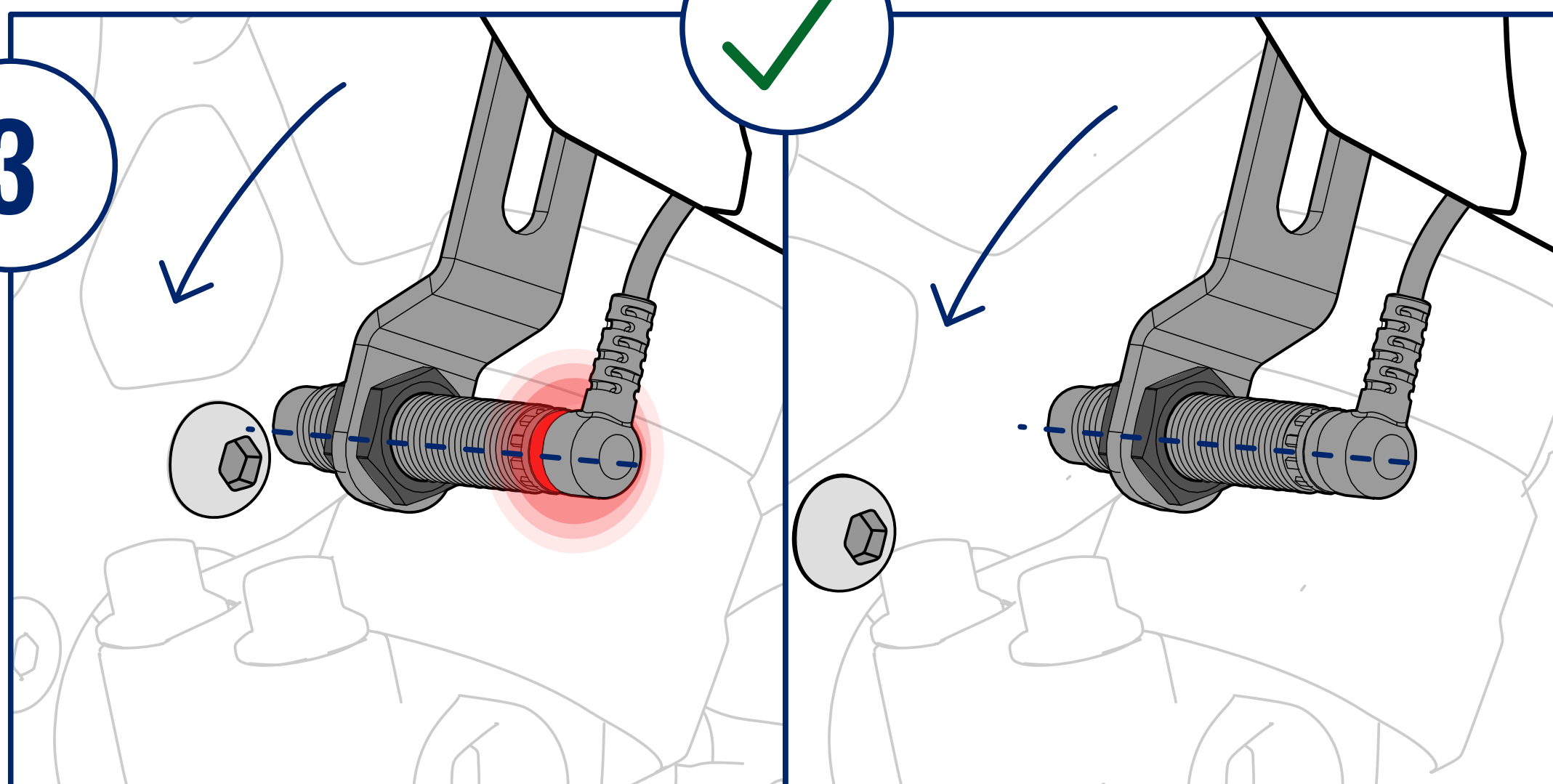

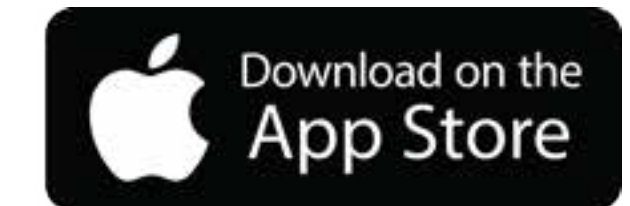
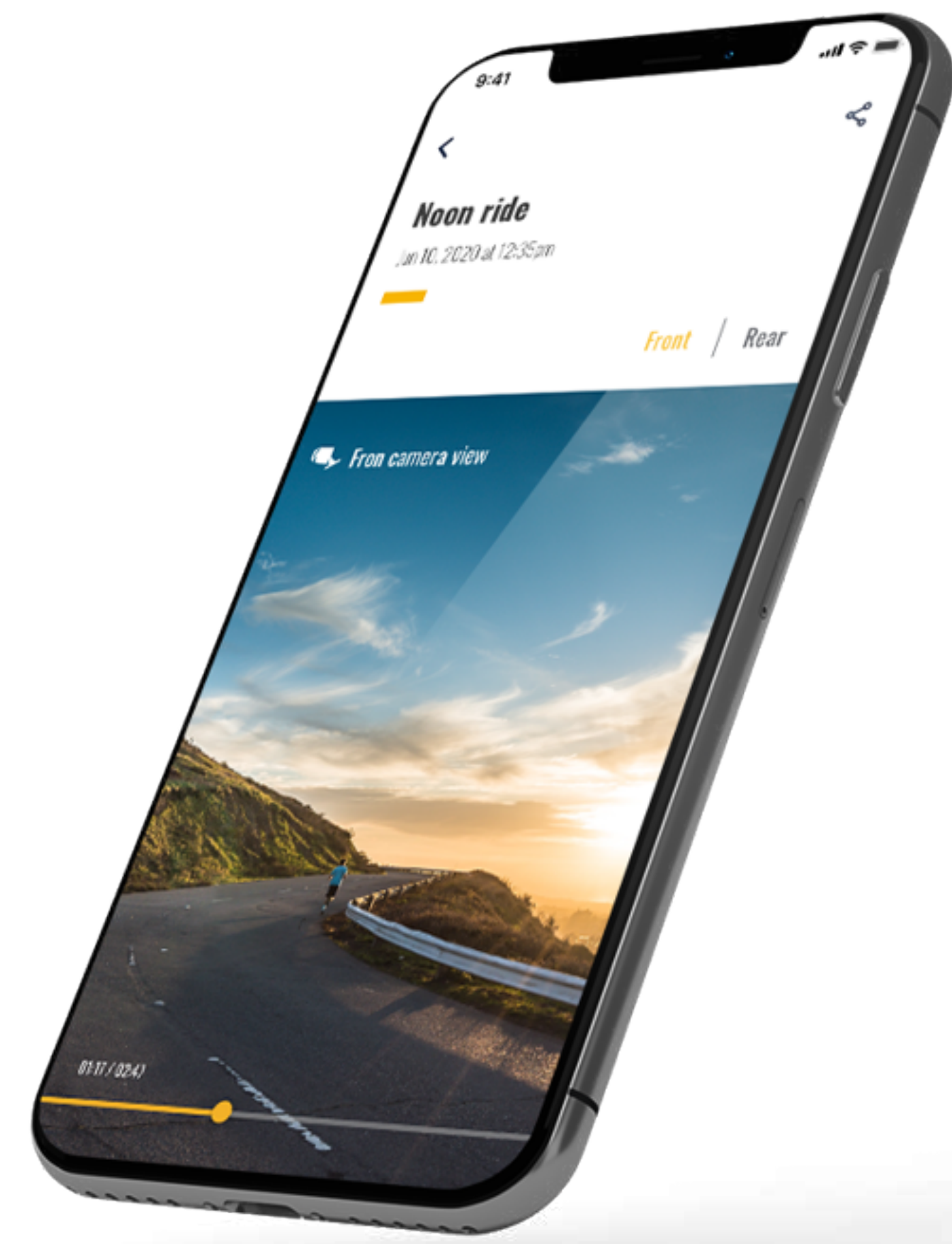

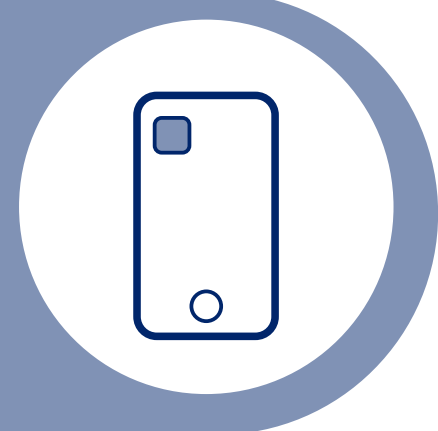

1 Registration

The registration form features the RideVision logo at the top, followed by input fields for 'Username' and 'Password'. A 'Forgot your password?' link is positioned below the password field. A 'Login' button is located at the bottom of the form. A dark blue banner at the very bottom contains the text 'New to RideVision?' and 'Start Here!' with a red arrow pointing to the latter.

2 Unit update

The screenshot shows a dark blue navigation menu with the RideVision logo and tagline 'Saving Riders' Lives'. The menu items are: 'Ride Safe', 'Unit Update' (highlighted with a red arrow), 'Unit Settings', 'What's new?', 'Support', and 'Send Bug Report'. A 'Log out' button is at the bottom. The background shows a blurred list of items with 'Distance' values: 17.30 km, 5.30 km, and 0.80 km.

3 Calibration

The screenshot shows the 'Unit Settings' menu in the RideVision app. The menu items are: 'Unit Update', 'Unit Settings' (highlighted with a red arrow), 'Alert Sensitivity', 'Led Brightness', 'WIFI Password', 'Video Recording', 'Unit Calibration' (highlighted with a red arrow), 'What's new?', 'Support', and 'Send Bug Report'. A 'Log out' button is at the bottom.

- i. **Do not fully screw in one side at a time. Tighten both sides incrementally until complete.**
- ii. If camera is misaligned at the end of the process, **fully** open the camera position screws and return to calibration stage 5.b
- d. Remove the calibration ruler.
- e. Remove **only the blue protector** from the camera lens.
 - i. Note: Each camera has 2 protectors:
 1. Blue protector - for shipping purposes
 2. Clear hydrophobic protector - **do not remove this protector.**
- f. You can now see the camera feed in the app [screenshot 21].
- g. Press Next
- h. Repeat stages 5.a - 5.g for the rear camera calibration [screenshot 22].
- i. Note: Do not use Manual calibration method unless instructed by RideVSION team.



18-19-20



Calibrating the front camera

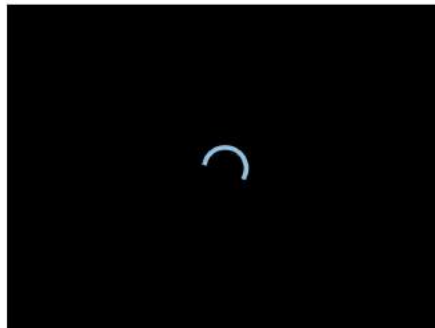

21



Calibrating the rear camera

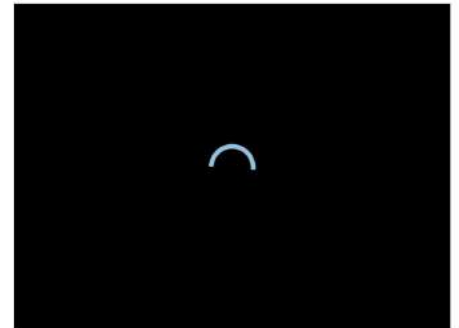

22

10. Press done.
11. Turn the ignition switch OFF

Your system is now ready.

On each new ride - after the following terms have been met:

1. ~7 seconds passed from turning motorcycle ignition ON
2. Motorcycle speed is above 5KPH

You should see both blindspot lights blink twice (2 yellow lights), this means the system is armed.

