

- ASSEMBLY GUIDE -

# SHELF LIBRARY COLLECTION

Steel

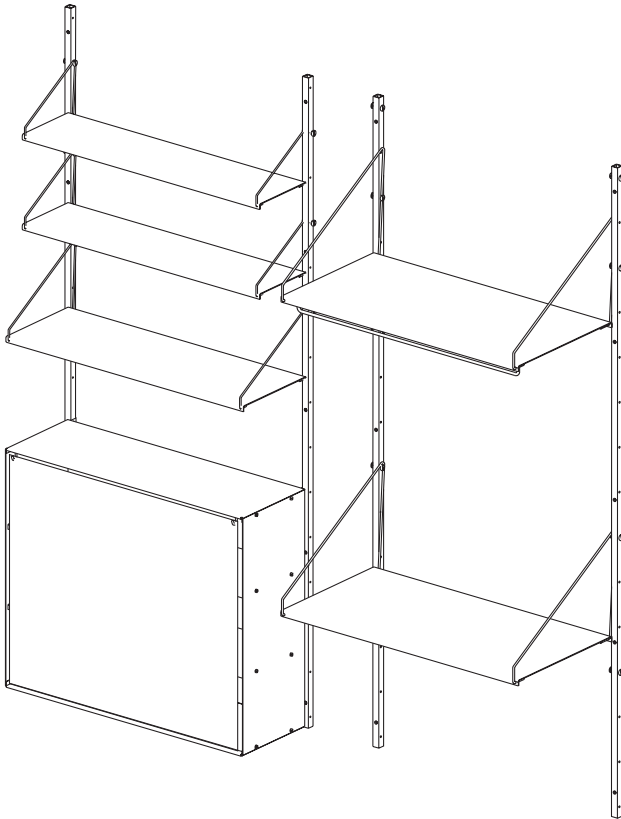

# FRAMA

# INDEX

3 Rail .....

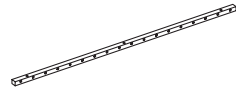

7 Shelf .....

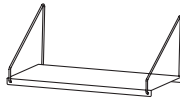

11 Hanger shelf .....



16 Cabinet .....

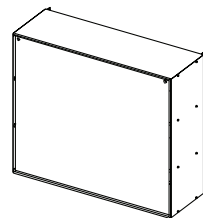

## RAIL - PARTS -



**A** Rail



**B** Screw  
x4 for 1084 rail  
x5 for 1852 rail

1.

Place the first rail **(A)** on the desired position on the wall and put the screw **(B)** into the wall through the top hole. Depends on the wall type, pre-drilling and wall plug (not included) maybe required.

Use the the top hole as an anchor point and level the rail straight then mark the screw hole with a pencil or a sharp tool on the wall.

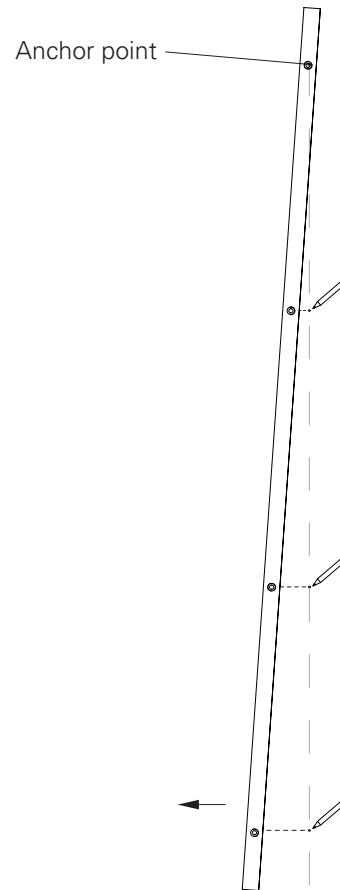
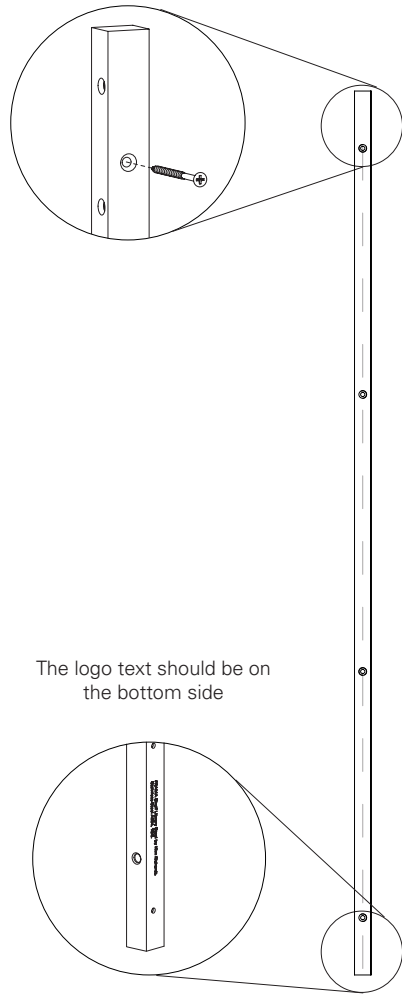

2.

Finish mounting the first rail by putting the screws **(B)** into the marked position. Measure the distances for the second rail **(A)**, then mount the second rail by repeating the same process on page 3.

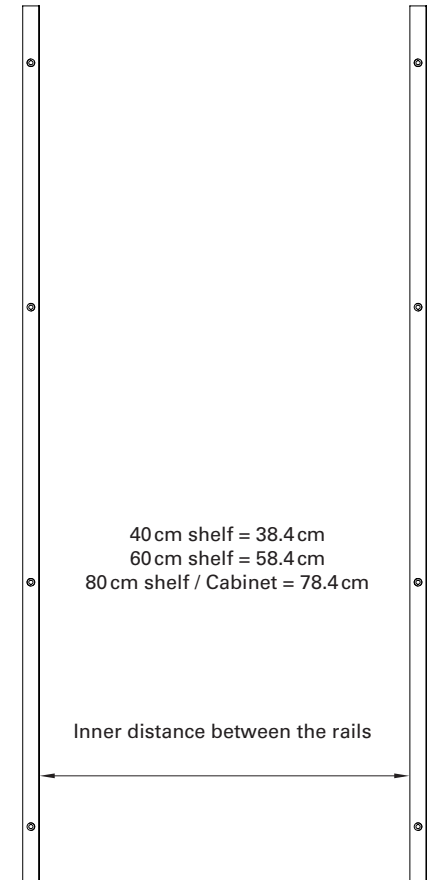
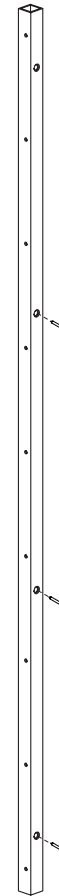

3.

To extend the system, repeat the same process on page 3 and 4.

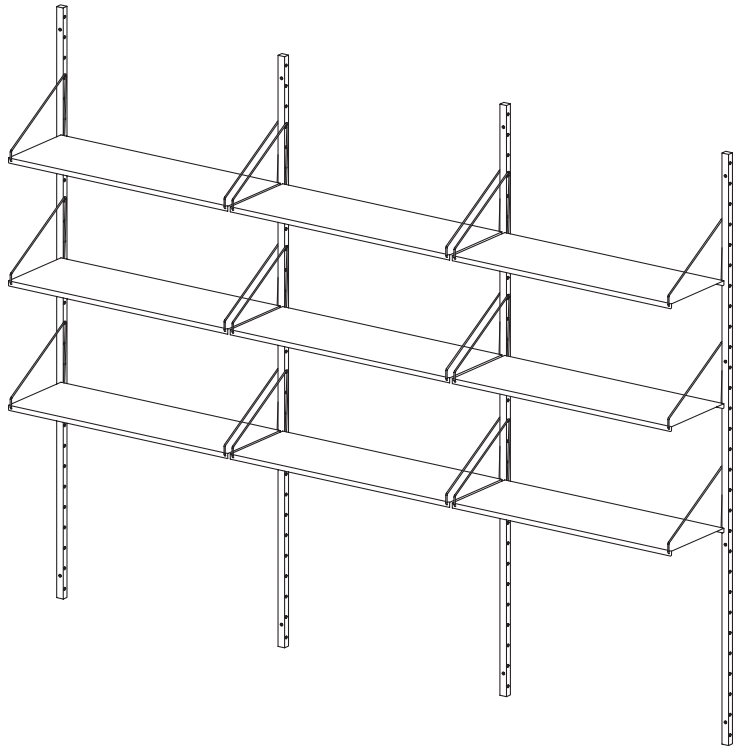

## SHELF

- PARTS -



**(A)** Shelf x1

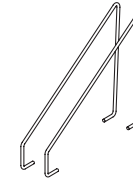

**(B)** Bracket x2

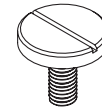

**(C)** Bolt x4

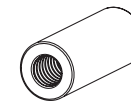

**(D)** Threaded insert x2

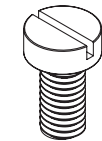

**(E)** Spacing bolt x1

Only **(A)**, **(B)**, **(C)** are required for this assembly.

1.

Start by inserting bracket ends **(B)** into the holes on the shelf **(A)**.

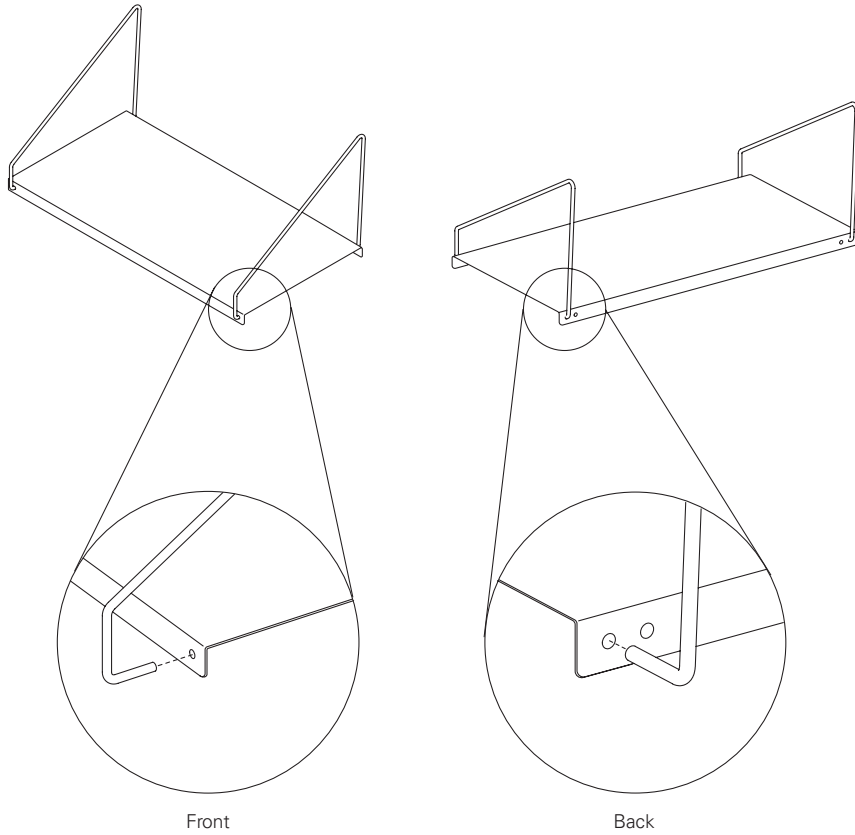

2.

Place the shelf at a desired position in the rail, secure the bracket **(B)** to the rail by fastening the bolts **(C)** to the threaded hole in the rail.

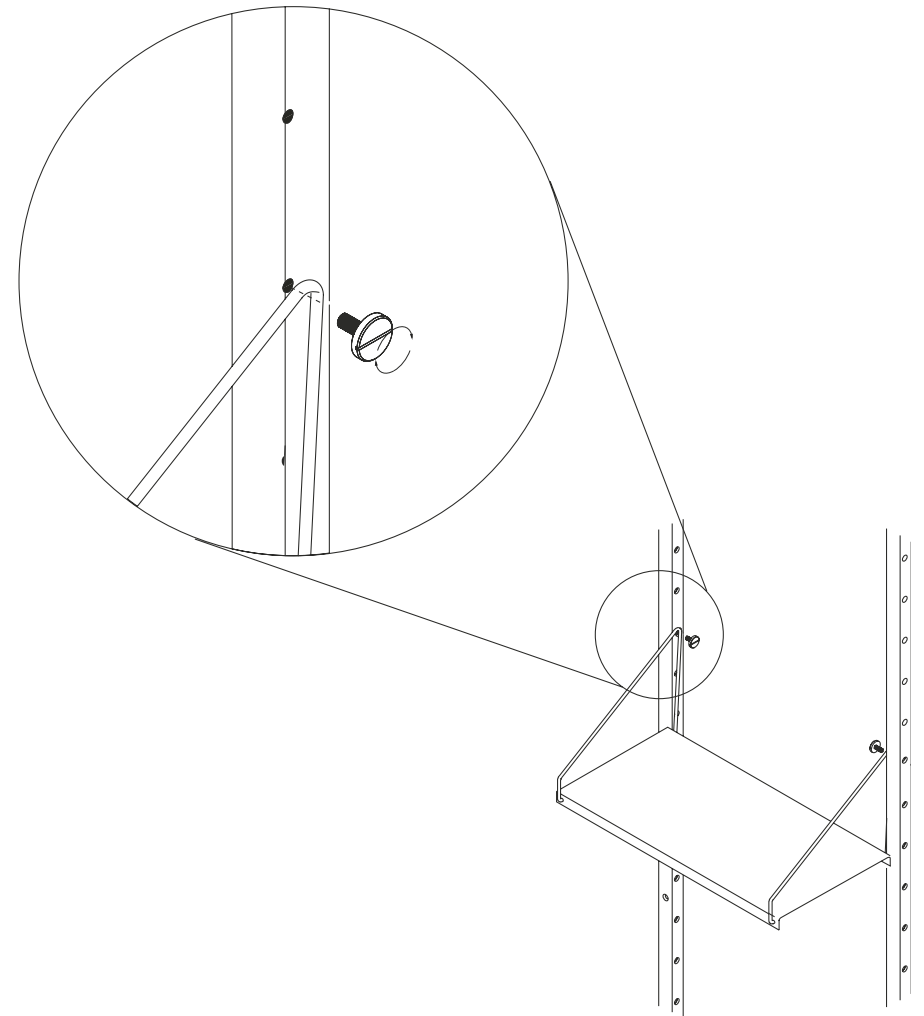

3.

Note that the back side of the shelf should be placed against the rail not to the wall.

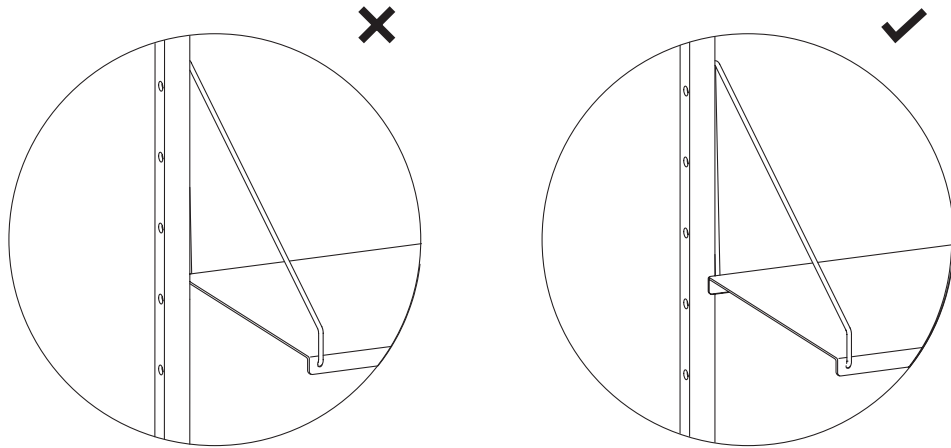

## HANGER SHELF

- PARTS -

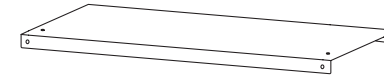

**A** Shelf x1



**B** Hanger x1

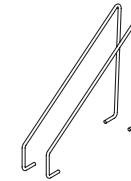

**C** Bracket x2

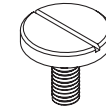

**D** Bolt x4

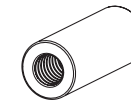

**E** Threaded insert x2

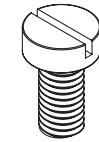

**F** Hanger / Spacing bolt x3

Only **A**, **B**, **C**, **D**, **F** are required for this assembly.

1.

Start by screwing the hanger bolts (F) into the hanger (B) though the shelf (A).

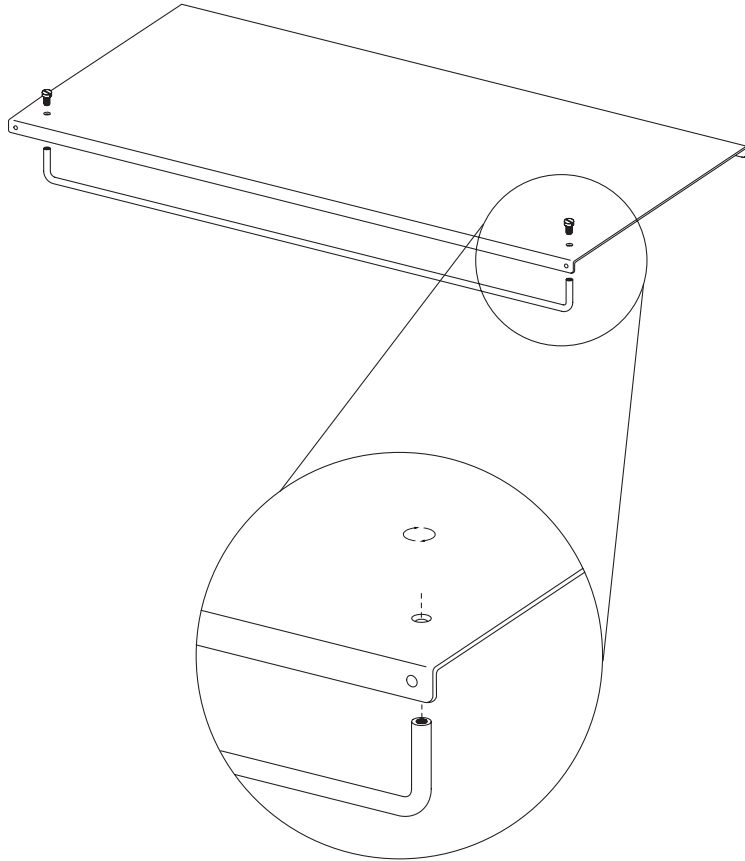

2.

Insert bracket ends (C) into the holes on the shelf (A).

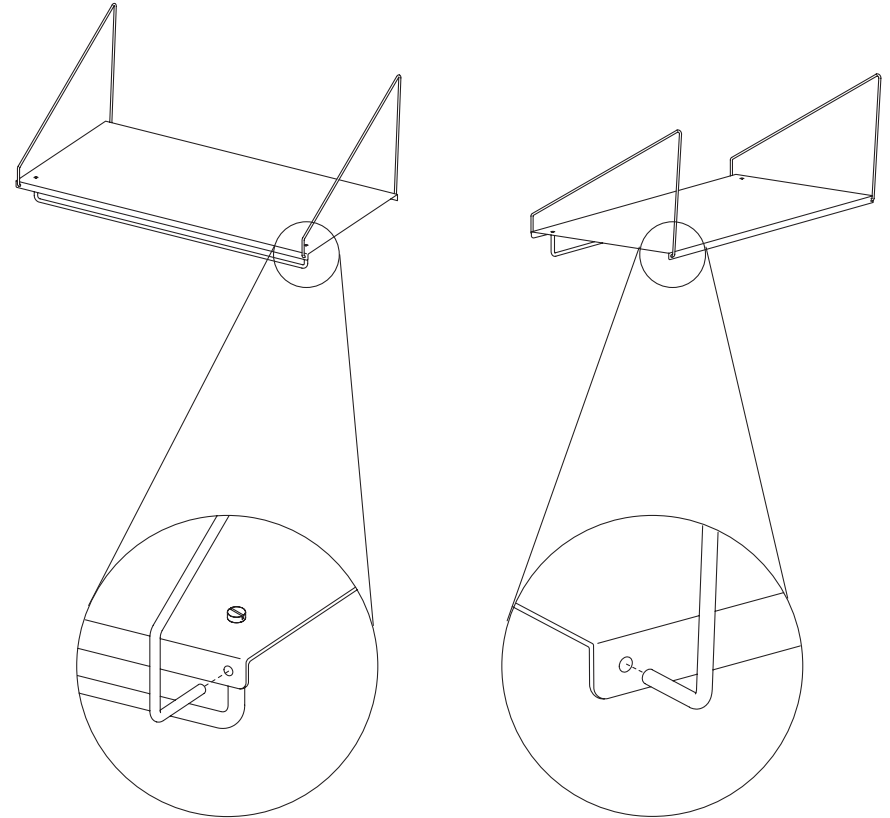

Front

Back

3.

Place the shelf at a desired position in the rail, secure the bracket **C** to the rail by fastening the bolts **D** to the threaded hole in the rail.

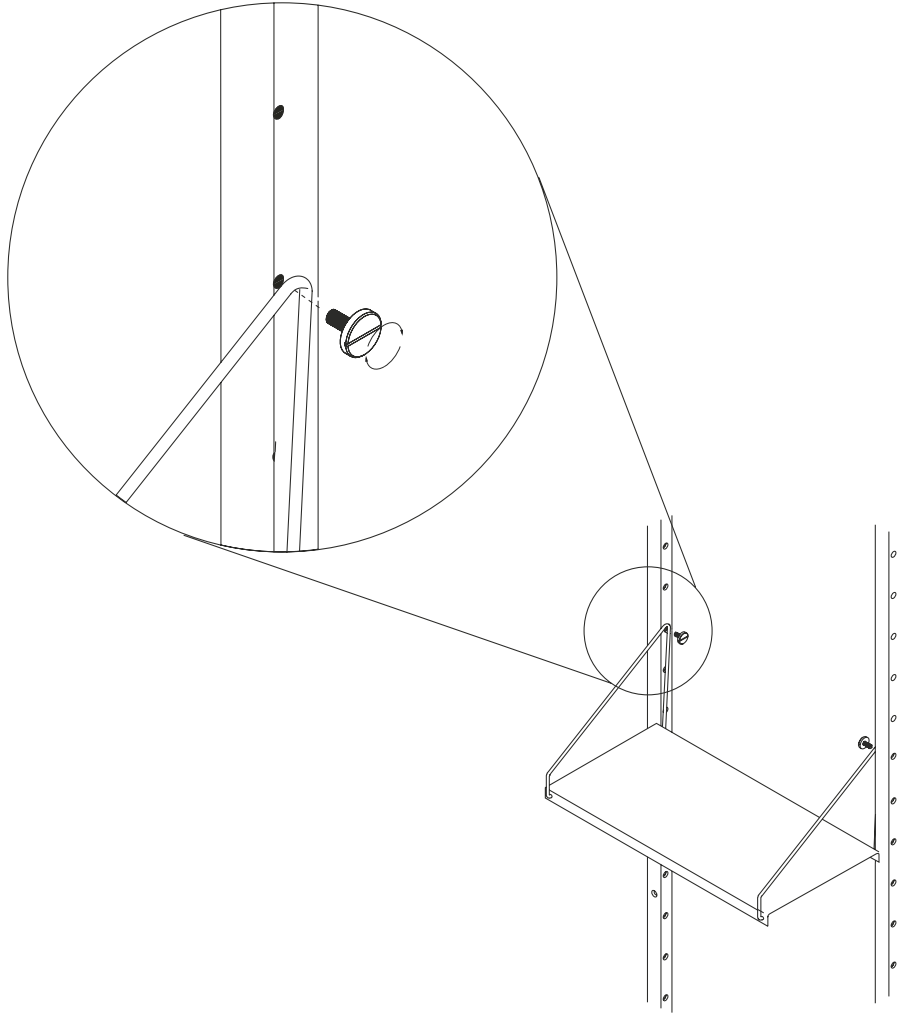

4.

Note that the back side of the shelf should be placed against the rail not to the wall.

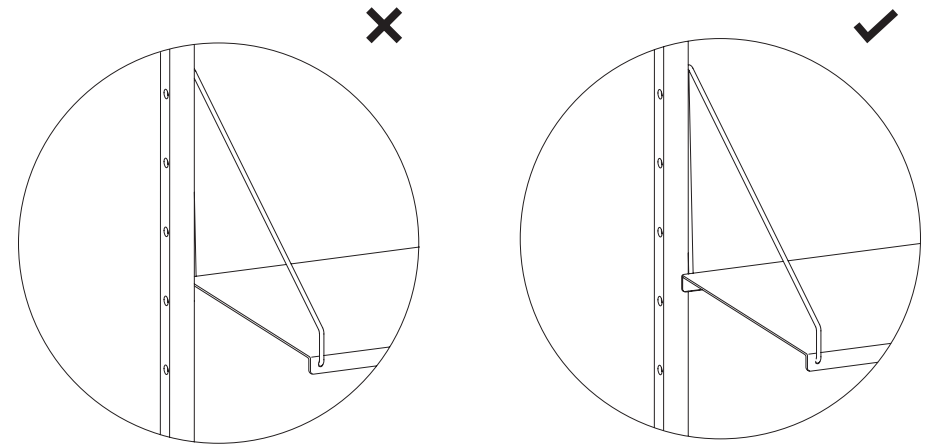



# SHELF LIBRARY CABINET

- PARTS -

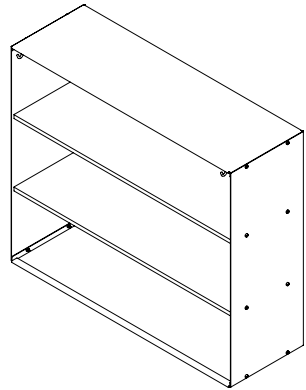

**(A)** Cabinet

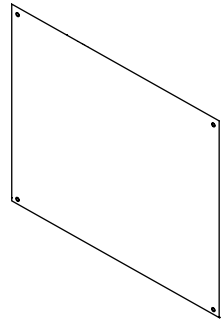

**(B)** Curtain



**(C)** Mounting screw x4



**(D)** Mounting hook x2

1.

Fasten the mounting hooks **(D)** to the rails using the Mounting screw **(C)**

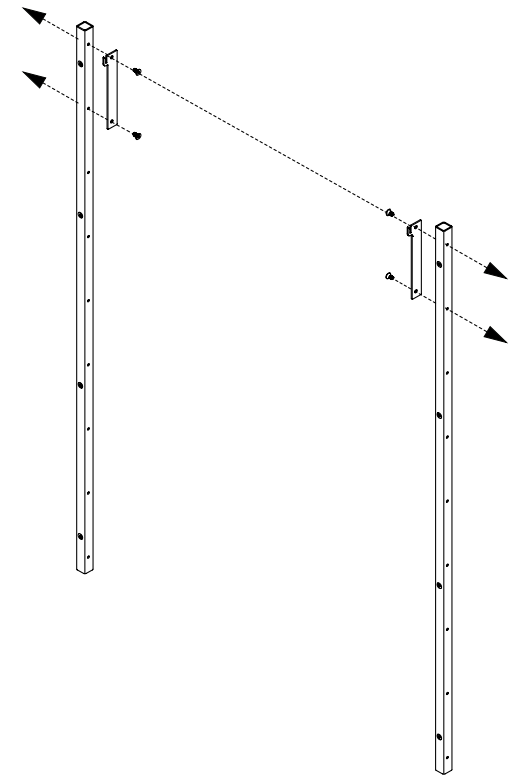

2.

Place the cabinet on the rail with the mounting hooks attached.

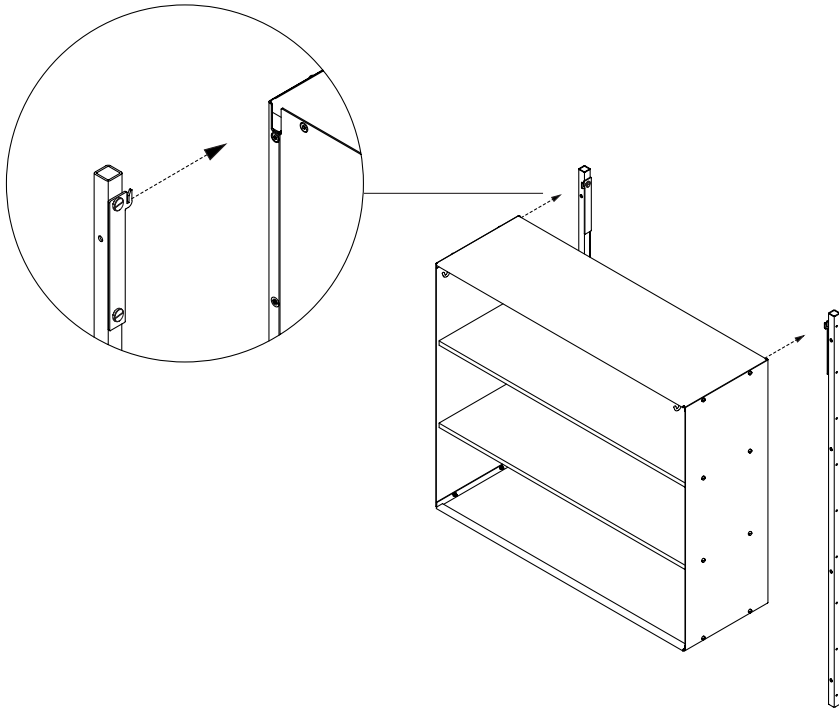

3.

Put the canvas curtain **(B)** on the cabinet by placing the holes in the hooks.

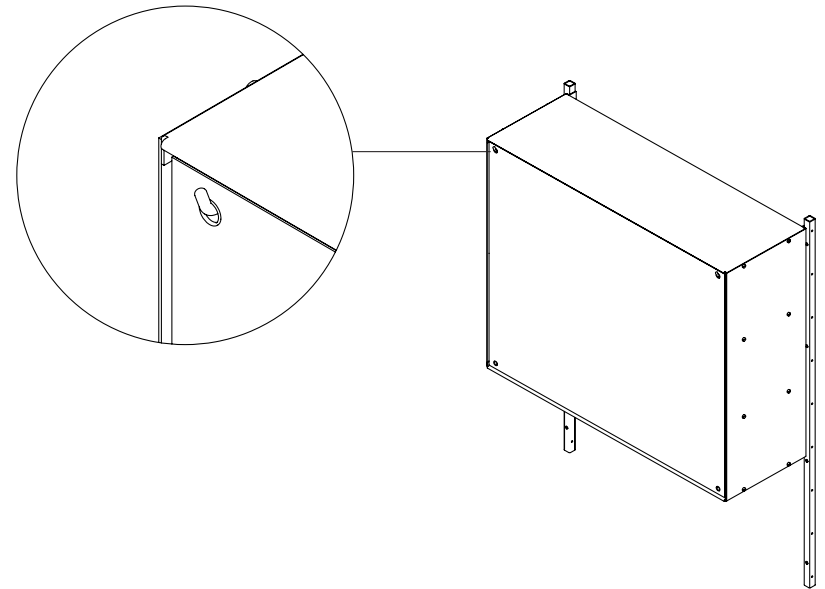

4.

Different configurations with canvas curtain are possible.

- Care & Maintenance Guide-

In order to preserve your new FRAMA pieces for years to come, we've produced a guide on the materials we use and how to best care for them. Following these instructions will help to maintain the appearance and quality of your items after repeated use and cleaning.

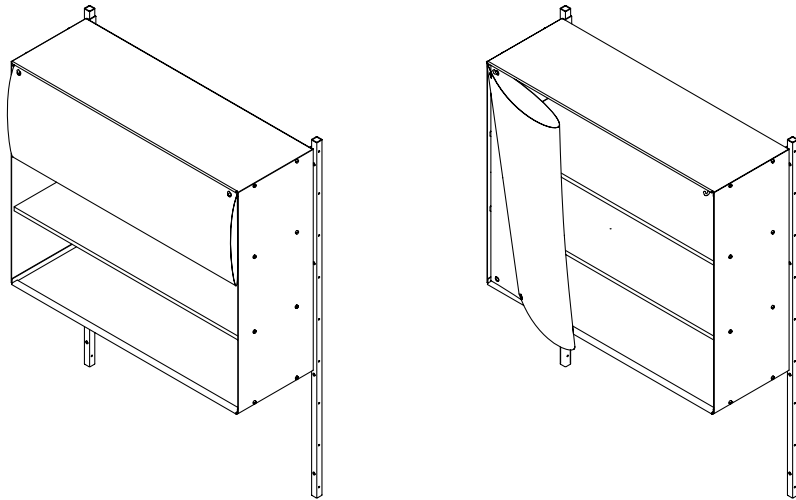

For material care and maintenance instructions, scan the QR code using your mobile device.



Access the guide on your desktop at  
[framacph.com/pages/material-care-guide](https://framacph.com/pages/material-care-guide)

FRAMA  
Fredericiagade 57, 1310  
Copenhagen K  
+45 3140 6030 [framacph.com](http://framacph.com)

**FRAMA**