

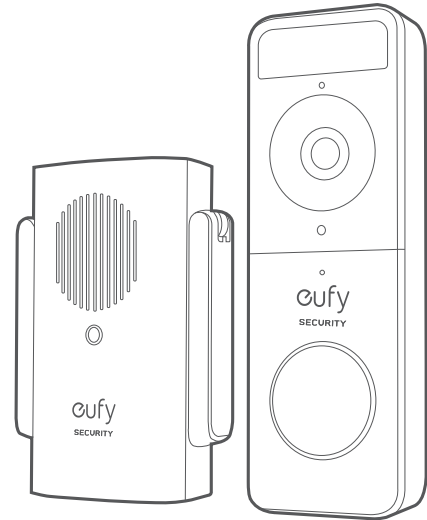

# QUICK START GUIDE

Video Doorbell Slim (1080p, Battery-Powered)



Anker Innovations Limited. All rights reserved. eufy Security and eufy Security Logo are trademarks of Anker Innovations Limited, registered in the United States and other countries. All other trademarks are the property of their respective owners.

51005002374 V01

English	01
Deutsch	20
Español	37
Français	54
Italiano	71
Nederlands	88
Português	105
لَعَرَبِيَّة	122

# TABLE OF CONTENTS

What's Included	01	09	Finding a Mounting Spot
Product Overview	03	11	Mounting the Bracket
How the System Works	04	14	Mounting the Doorbell
Powering on the Wi-Fi Doorbell Chime	05	15	Detaching the Doorbell
Setting up the System	07	16	Recharging the Doorbell
Charging Your Doorbell	08	17	Notice

# WHAT'S INCLUDED

## For Video Doorbell Installation



Video Doorbell Slim  
(1080p, Battery-Powered)  
Model: T8220

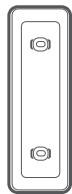

Mounting Bracket



Screw Hole  
Positioning Card



15° Mounting  
Wedge  
(Optional)

FCC ID: 2AOKB-T8220  
IC: 23451-T8220



USB Charging  
Cable

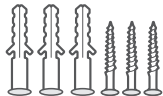

Screw Packs (Spare  
screws and anchors are  
included)



Doorbell  
Detaching Pin



Quick Start  
Guide

## For Wi-Fi Doorbell Chime Installation



Model: Wi-Fi Doorbell Chime  
FCC ID: 2AOKB-T8020  
IC: 23451-T8020

Power Plug

Note: Power plug may vary in different regions.

# PRODUCT OVERVIEW

## Video Doorbell (Battery Powered)

Front view:

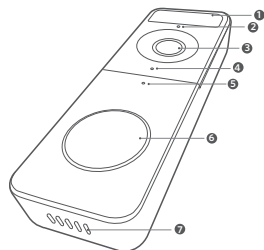

1. Motion Sensor
2. Microphone
3. Camera Lens
4. Ambient Light Sensor
5. Status LED
6. Doorbell Button
7. Speaker

Rear View:

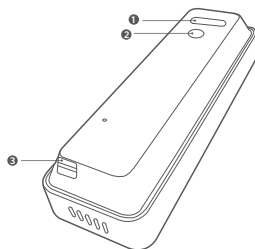

1. Micro USB Charging Port
2. SYNC/RESET button
3. Detaching Mechanism

Operation	How-to
Power on	Press and release the SYNC button.
Add doorbell to Wi-Fi Doorbell Chime	Press and hold the SYNC button until you hear a beep.
Power off the doorbell	Quick-press the SYNC 5 times in 3 seconds.
Reset the doorbell	Press and hold the SYNC button for 10 seconds.

# HOW THE SYSTEM WORKS

## How the System Works

The video doorbell system includes 2 parts:

- The video doorbell at your door
- The Wi-Fi Doorbell Chime in your house

The video doorbell detects motion at your porch and allows you to answer the door anytime and anywhere. The Wi-Fi Doorbell Chime stores video clips on a microSD card (user provides it) and works as an indoor digital chime. When someone rings the doorbell, people in the house will be notified.

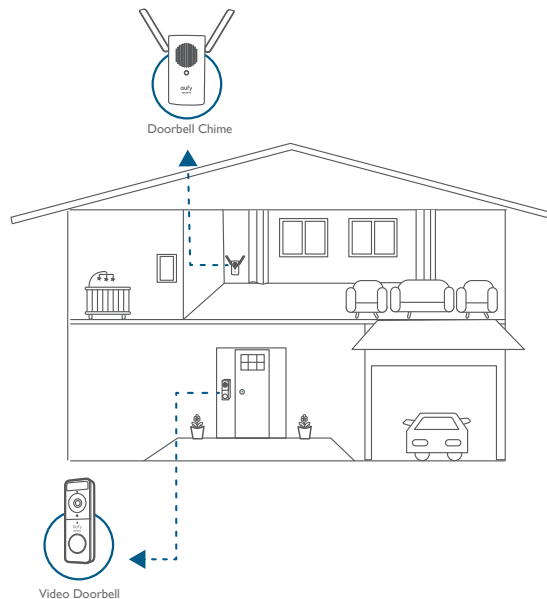



# STEP 1 POWERING ON THE WI-FI DOORBELL CHIME

## Connect the HomeBase 2 to the Internet

### 1. Fix the power connector to Wi-Fi Doorbell Chime.

- 1 Place the power connector over Wi-Fi Doorbell Chime in the direction the arrows indicate.
- 2 Align the raised slots of the power connector with the notch on the base of the doorbell chime.
- 3 Rotate clockwise to lock the power connector in place.

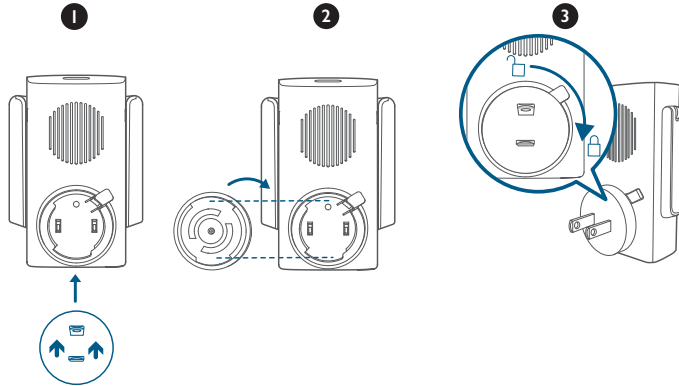

### 2. Extend Wi-Fi Doorbell Chime's antennas.

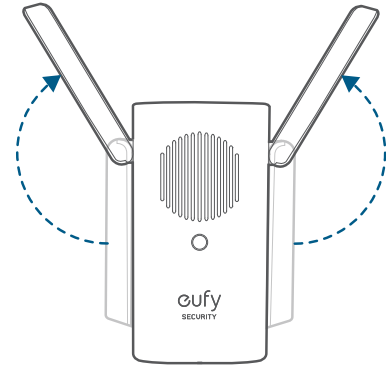

3. Plug Wi-Fi Doorbell Chime into an AC power supply at your desired location. The LED indicator turns solid green when the doorbell chime is ready for setup.

## STEP 2 SETTING UP THE SYSTEM

### Download the App and Set up the System

Download the eufy Security app from the App Store (iOS devices) or Google Play (Android devices).



Sign up for a eufy Security account and follow onscreen instructions to complete the setup.

Tap Add Device and add the following devices:

1. Add the Wi-Fi Doorbell Chime.
2. Add the doorbell.

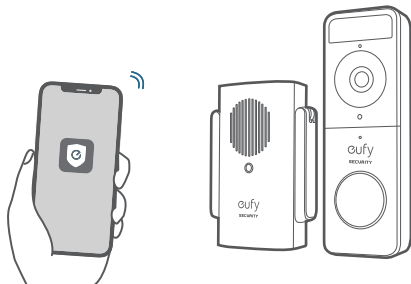

## STEP 3 CHARGING YOUR DOORBELL

The doorbell comes with an 80% battery level for safe transportation. Fully charge it before mounting the doorbell at your front door.

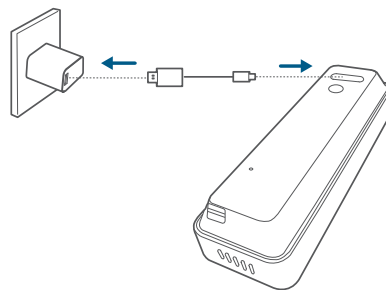

**Note:** The battery life varies depending on usage. In most common cases, a doorbell may have up to 15 events per day and each recording lasts 20 seconds on average. Under this scenario, the doorbell battery life can last up to 4 months.

# STEP 4 FINDING A MOUNTING SPOT

## Find a Mounting Spot

Take the Video Doorbell to your front door and check the live view on the eufy Security app at the same time. Find a position where you can get the desired field of view.

Consider the below factors:

1. Check if you can reuse the existing holes and anchors on the wall or door frame.
2. If you want to place the doorbell close to a side wall, make sure the wall doesn't show up in the field of view. Otherwise IR light will be reflected and night vision will become blurry.
3. If you are drilling the mounting holes for the first time the recommended mounting height is 48" / 1.2m from the ground.
4. Use the 15° mounting wedge as a supplementary mounting bracket if you wish to see more on a specific side.

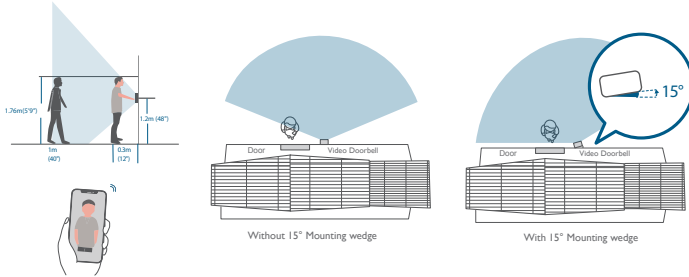

Place the Screw Hole Positioning Card against the wall to mark the position.

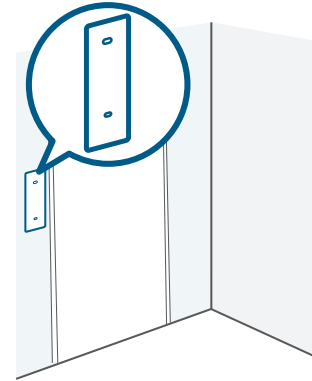

# STEP 5 MOUNTING THE BRACKET

## Mount the Doorbell on a Wooden Surface

If you're mounting the doorbell on a wooden surface, you don't need to pre-drill pilot holes. Use the provided screws to secure the Mounting Bracket on the wall. The Screw Hole Positioning Card indicates the position of the screw holes.

**What is required: Power Drill, Mounting Bracket, 15° Mounting Wedge (Optional), Screw Packs**

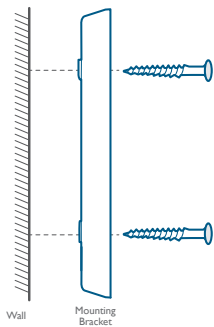
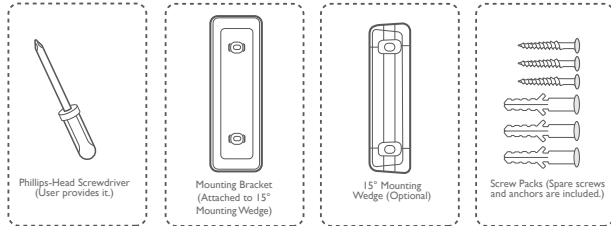

Without 15° Mounting Wedge

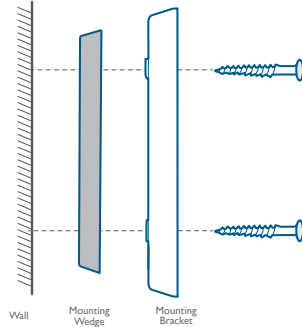

With 15° Mounting Wedge

## Mount the Video Doorbell on Surfaces Made Out of Hard Materials

1. If you're mounting the doorbell on a surface made out of hard materials, like brick, concrete, stucco, drill 2 holes through the Screw Hole Positioning Card with 15/64"(6mm) drill bit.
2. Insert the provided anchors, and then use the provided long screws to secure the Mounting Bracket on the wall.

**What is required: Power Drill, 15/64"(6mm) Drill Bit, Mounting Bracket, 15° Mounting Wedge (Optional), Screw Packs**

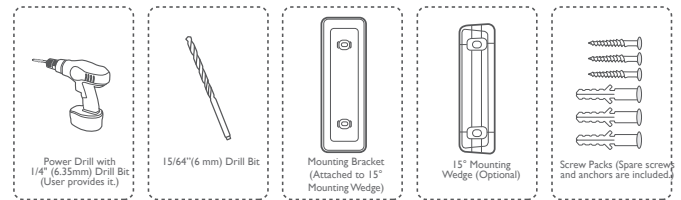

2

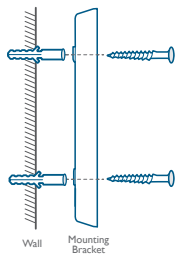

Wall Mounting Bracket

Without 15° Mounting Wedge

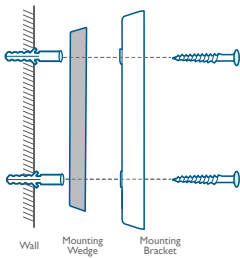

Wall Mounting Wedge Mounting Bracket

With 15° Mounting Wedge

## STEP 6 MOUNTING THE DOORBELL

### Mount the Doorbell

Align the doorbell with the top of the mount and then snap the bottom into place.

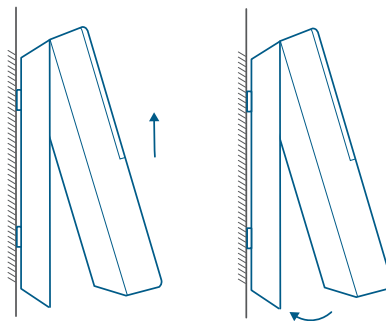

You're all set!

If you want to detach the doorbell or recharge it, please refer to the following sections.

# APPENDIX I DETACHING THE DOORBELL

## Detach the Doorbell

1. Use the doorbell detaching pin provided if you wish to detach the doorbell from the Mounting Bracket.
2. Insert and press the detaching pin into the hole on the bottom of the doorbell and then lift to take the bottom of the doorbell off.

What is required: Doorbell Detaching Pin

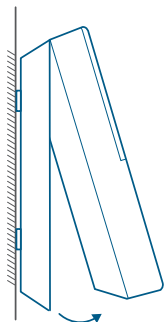
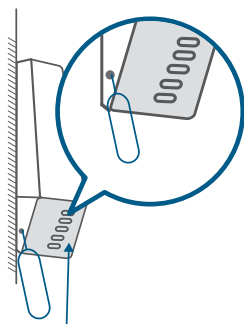
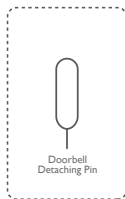

# APPENDIX 2 RECHARGING THE DOORBELL

## Recharge the Doorbell

Charge the doorbell with universal USB chargers that deliver 5V 1A output.

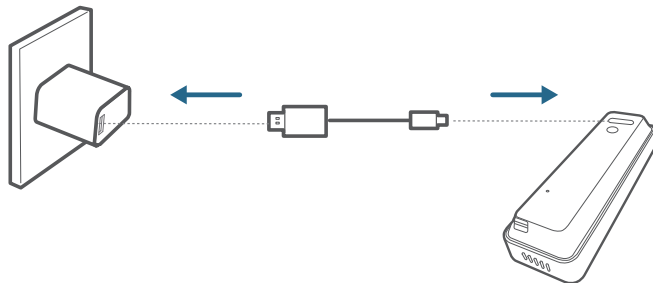

LED indication	Charging: Solid orange
	Fully charged: Solid blue
Charging time	6 hours from 0% to 100%

# NOTICE

## FCC Statement

This device complies with Part 15 of the FCC Rules. Operation is subject to the following two conditions: (1) this device may not cause harmful interference, and (2) this device must accept any interference received, including interference that may cause undesired operation.

**Warning:** Changes or modifications not expressly approved by the party responsible for compliance could void the user's authority to operate the equipment.

**Note:** This equipment has been tested and found to comply with the limits for a Class B digital device, pursuant to Part 15 of the FCC Rules. These limits are designed to provide reasonable protection against harmful interference in a residential installation.

This equipment generates uses and can radiate radio frequency energy and, if not installed and used in accordance with the instructions, may cause harmful interference to radio communications. However, there is no guarantee that interference will not occur in a particular installation. If this equipment does cause harmful interference to radio or television reception, which can be determined by turning the equipment off and on, the user is encouraged to try to correct the interference by one or more of the following measures: (1) Reorient or relocate the receiving antenna. (2) Increase the separation between the equipment and receiver. (3) Connect the equipment into an outlet on a circuit different from that to which the receiver is connected. (4) Consult the dealer or an experienced radio / TV technician for help.

## FCC Radio Frequency Exposure Statement

The device has been evaluated to meet general RF exposure requirements. The device can be used in fixed/mobile exposure condition. The min separation distance is 20cm.

**Notice:** Shielded cables

All connections to other computing devices must be made using shielded cables to maintain compliance with FCC regulations.

The following importer is the responsible party:

Company Name: POWER MOBILE LIFE, LLC

Address: 400 108th Ave NE Ste 400, Bellevue, WA 98004-5541

Telephone: 1-800-988-7973



This product complies with the radio interference requirements of the European Community.

## Declaration of Conformity

Hereby, Anker Innovations Limited declares that this device is in compliance with the essential requirements and other relevant provisions of Directive 2014/53/EU. For the declaration of conformity, visit the Web site: <https://www.eufylife.com/>.

This product can be used across EU member states.

Do not use the Device in the environment at too high or too low temperature, never expose the Device under strong sunshine or too wet environment.

The suitable temperature for T8020 and accessories is 0°C-40°C.

The suitable temperature for T8220 is -20°C-50°C.

When charging, please place the device in an environment that has a normal room temperature and good ventilation.

It is recommended to charge the device in an environment with a temperature that ranges from 5°C~25°C.

RF exposure information: The Maximum Permissible Exposure (MPE) level has been calculated based on a distance of d=20 cm between the device and the human body. To maintain compliance with RF exposure requirement, use product that maintain a 20cm distance between the device and human body.

**CAUTION RISK OF EXPLOSION IF BATTERY IS REPLACED BY AN INCORRECT TYPE. DISPOSE OF USED BATTERIES ACCORDING TO THE INSTRUCTIONS**

Wifi Operating Frequency Range: 2412~2472MHz (2.4G)

Wifi Max Output Power: 15.68dBm (ERIP for T8020); 15.01dBm (ERIP for T8220)

Bluetooth Operating Frequency Range: 2402~2480MHz; Bluetooth Max Output Power: 2.048dBm (EIRP)

The following importer is the responsible party (contact for EU matters only)

Anker Innovations Deutschland GmbH, Georg-Muche-Straße 3-5, 80807 München

Anker Technology (UK) Ltd, Suite B, Fairgate House, 205 Kings Road, Tyseley,

Birmingham, B11 2AA, United Kingdom



This product is designed and manufactured with high quality materials and components, which can be recycled and reused.



This symbol means the product must not be discarded as household waste, and should be delivered to an appropriate collection facility for recycling. Proper disposal and recycling helps protect natural resources, human health and the environment. For more information on disposal and recycling of this product, contact your local municipality, disposal service, or the shop where you bought this product.

## IC Statement

This device complies with Industry Canada licence-exempt RSS standard(s). Operation is subject to the following two conditions:

- (1) this device may not cause interference, and
- (2) this device must accept any interference, including interference that may cause undesired operation of the device."

This Class B digital apparatus complies with Canadian ICES-003.

Cet appareil numérique de la classe B est conforme à la norme NMB-003 du Canada.

## IC RF Statement:

When using the product, maintain a distance of 20cm from the body to ensure compliance with RF exposure requirements.

Lors de l'utilisation du produit, maintenez une distance de 20 cm du corps afin de vous conformer aux exigences en matière d'exposition RF.

# INHALTS- VERZEICHNIS

Im Lieferumfang	21	29	Suchen eines Befestigungsortes
Produktübersicht	23	31	Anbringen der Halterung
Funktionsweise des Systems	24	34	Anbringen der Türklingel
Einschalten des WLAN-Türgongs	25	35	Abnehmen der Türklingel
Einrichten des Systems	27	36	Aufladen der Türklingel
Aufladen Ihrer Türklingel	28	37	Hinweise



# IM LIEFERUMFANG

## Für die Installation der Video-Türklingel



Video-Türklingel Schmal  
(1080 p, Akkubetrieb)  
Modell: T8220

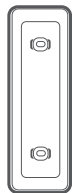

Montagehalterung



Bohrschablone



15°-Montagewinkel  
(optional)

FCC ID: 2AOKB-T8220  
IC: 23451-T8220



USB-Ladekabel

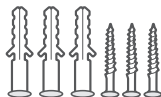

Schrauben (mit  
Ersatzschrauben und  
Dübel)



Türklingel-  
Lösestift



Kurzanzleitung

## Zur Installation des WLAN-Türgongs



Modell: WLAN-Türgong  
FCC ID: 2AOKB-T8020  
IC: 23451-T8020

Netzstecker

Hinweis: Die Ausführung des Netzsteckers hängt von der jeweiligen Region ab.

# Produktübersicht

## Video-Türklingel (Akkubetrieb)

Vorderseite:

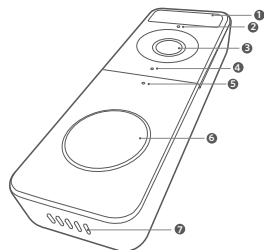

1. Bewegungssensor
2. Mikrophon
3. Kameraobjektiv
4. Umgebungslichtsensor
5. Status-LED
6. Türklingeltaste
7. Lautsprecher

Rückseite:

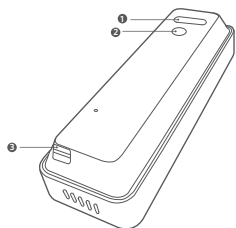

1. Mikro-USB-Ladeanschluss
2. Taste SYNC/RESET
3. Abnahmemechanismus

Betrieb	Anleitung
Eingeschaltet	Drücken Sie die SYNC-Taste und lassen Sie sie los.
Türklingel zum WLAN-Türgong hinzufügen	Halten Sie die SYNC-Taste gedrückt, bis Sie ein Biep-Geräusch hören.
Abschalten der Türklingel	Drücken Sie innerhalb von 3 Sekunden 5 Mal hintereinander auf SYNC.
Zurücksetzen der Türklingel	Die SYNC-Taste 10 Sekunden lang gedrückt halten

# Funktionsweise des Systems

## Funktionsweise des Systems

Das Video-Türklingelsystem umfasst 2 Teile:

- Die an der Tür anzubringende Video-Türklingel
- Den WLAN-Türgong in Ihrem Haus

Die Video-Türklingel erkennt Bewegungen vor Ihrer Haustür und ermöglicht es Ihnen, Gäste an der Tür jederzeit und überall zu empfangen. Der WLAN-Türgong speichert Video-Clips auf einer microSD-Karte (Bereitstellung durch den Benutzer) und dient als digitaler Innengong. Sobald jemand die Türklingel betätigt, werden die Personen im Haus darauf aufmerksam gemacht.

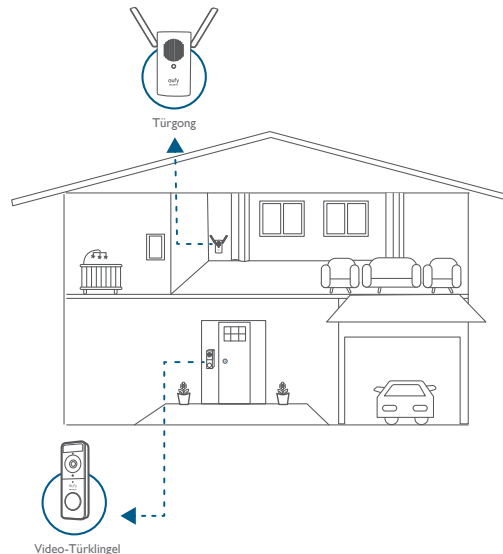

# SCHRITT I EINSCHALTEN DES WLAN-TÜRGONGS

## HomeBase 2 mit dem Internet verbinden

1. Befestigen Sie den Netzanschluss am WLAN-Türgong.
  - ① Positionieren Sie den Stromanschluss in der durch die Pfeile angegebenen Richtung auf dem WLAN-Türgong.
  - ② Richten Sie die erhöhten Einschiebe am Stromanschluss auf die Notch unten am Türgong aus.
  - ③ Drehen Sie den Stromanschluss im Uhrzeigersinn, um ihn einrasten zu lassen.

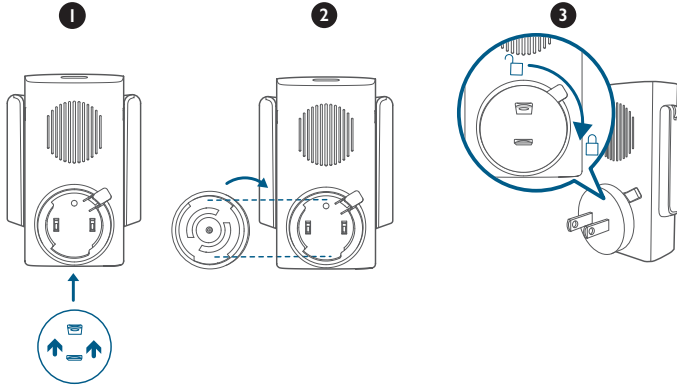

2. Klappen Sie die Antennen des WLAN-Türgongs aus.

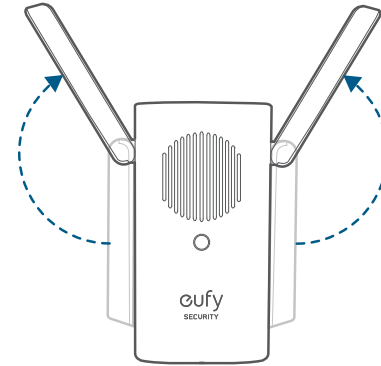

3. Stecken Sie den WLAN-Türgong in eine AC-Stromversorgung an beliebiger Stelle. Die LED-Anzeige wechselt zu einem dauerhaften Grün, wenn der Türgong zur Einrichtung bereit ist.

## SCHRITT 2 – EINRICHTUNG DES SYSTEMS

### Laden Sie die App herunter und richten Sie das System ein.

Laden Sie die eufy Security-App aus dem App Store (iOS-Geräte) oder bei Google Play (Android) herunter.



Registrieren Sie ein eufy Security-Konto und befolgen Sie die Anweisungen auf dem Bildschirm, um die Einrichtung abzuschließen.

Tippen Sie auf „Gerät hinzufügen“ und fügen Sie die folgenden Geräte hinzu:

1. Fügen Sie den WLAN-Türgong hinzu.
2. Fügen Sie die Türklingel hinzu.

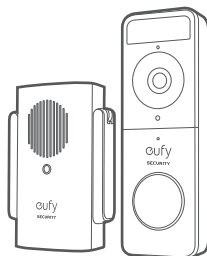
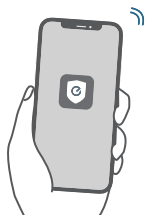

## SCHRITT 3 AUFLADEN IHRER TÜRKLINGEL

Die Türklingel wird für einen sicheren Transport mit einem Akkustand von 80 % ausgeliefert. Laden Sie die Türklingel vollständig auf, bevor Sie sie an Ihrer Haustür montieren.

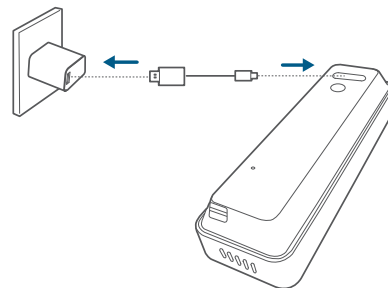

Hinweis: Die Verwendungszeit des Akkus hängt von der Verwendung ab. Unter normalen Umständen wird die Türklingel bis zu 15 Mal am Tag verwendet, und jede Aufnahme dauert durchschnittlich 20 Sekunden. Unter diesen Umständen kann der Akku bis zu 4 Monate halten.

# SCHRITT 4 – EINEN BEFESTIGUNGSPORT FINDEN

## Suchen Sie einen Befestigungsort

Bringen Sie die Video-Türklingel zu Ihrer Haustür und überprüfen Sie gleichzeitig die Echtzeitanzeige in der eufy Security-App. Suchen Sie eine Stelle, an der Sie das gewünschte Blickfeld erhalten.

Bedenken Sie die folgenden Faktoren:

1. Überprüfen Sie, ob Sie die bestehenden Löcher und Dübel an der Haustürwand erneut verwenden können.
2. Wenn Sie die Türklingel nahe einer Seitenwand anbringen möchten, achten Sie bitte darauf, dass die Wand nicht im Blickfeld der Kamera liegt. Ansonsten wird die Infrarotstrahlung reflektiert, und Nachtaufnahmen werden verschwommen dargestellt.
3. Wenn Sie die Befestigungslöcher das erste Mal in die Wand bohren, wird eine Höhe von 1,2 m über dem Boden empfohlen.
4. Die Verwendung des 15°-Montagewinkels als zusätzliche Montagehalterung empfiehlt sich, wenn ein größerer Blickumfang auf einer Seite gewünscht wird.

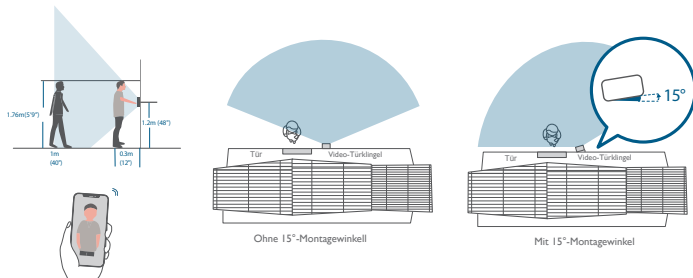

Halten Sie die Bohrschablone an die Wand, um die Positionen zu markieren.

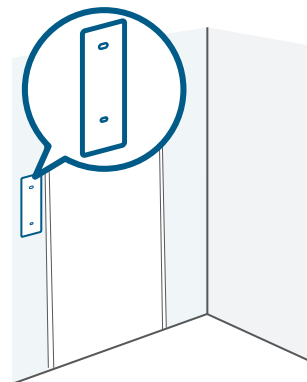

# SCHRITT 5 – ANBRINGEN DER HALTERUNG

## Anbringen der Türklingel an einer Oberfläche aus Holz

Wenn Sie die Türklingel an einer Oberfläche aus Holz anbringen, muss nicht vorgebohrt werden. Bringen Sie die Montagehalterung mit den gelieferten Schrauben an der Wand an. Mit der Bohrschablone wird die Position der Bohrlöcher angegeben.

Hierzu erforderlich: Bohrmaschine, Montagehalterung, 15°-Montagewinkel (optional), Schrauben

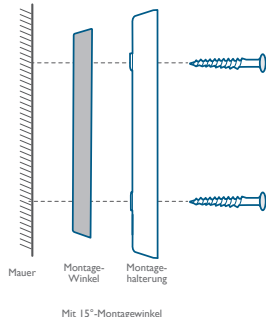
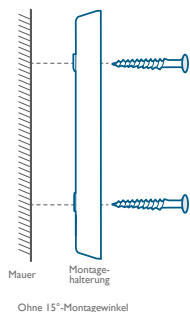
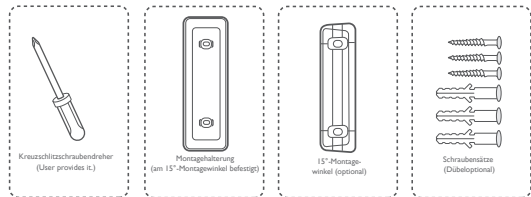

## Anbringen der Video-Türklingel an harten Oberflächen

1. Wenn Sie die Türklingel an Oberflächen aus hartem Material (z. B. Ziegelsteine, Beton, Stuck) anbringen, bohren Sie mit einem 15/64-Zoll-Bohreinsatz (6 mm) mit Hilfe der Bohrschablone zwei Löcher.
2. Stecken Sie die gelieferten Dübel rein und bringen Sie dann die Montagehalterung mit den Langschrauben an der Wand an.

Hierzu erforderlich: Bohrmaschine, 6-mm- bzw. 15/64-Zoll-Bohreinsatz, Montagehalterung, 15°-Montagewinkel (optional), Schrauben

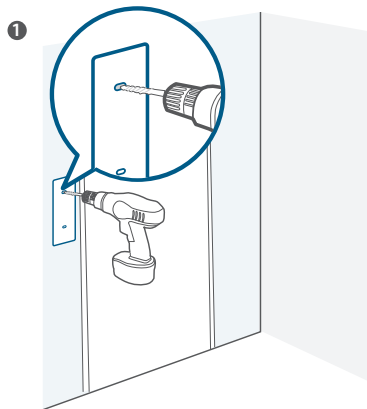
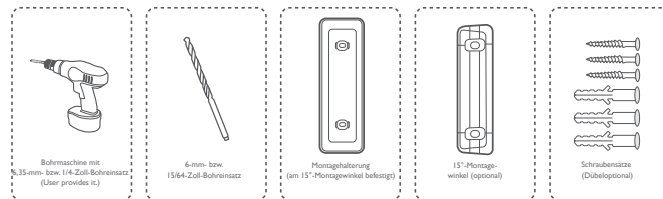

2

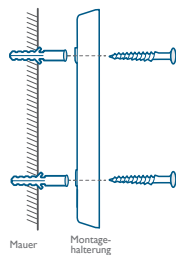

Mauer Montage-  
halterung

Ohne 15°-Montagewinkel

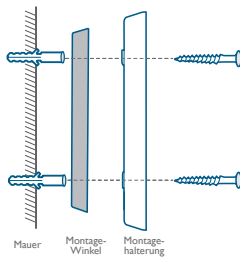

Mauer Montage-  
Winkel Montage-  
halterung

Mit 15°-Montagewinkel

## SCHRITT 6 – ANBRINGEN DER TÜRKLINGEL

### Die Türklingel anbringen

Richten Sie die Türklingel auf den oberen Teil der Halterung aus und lassen Sie anschließend den unteren Teil einrasten.

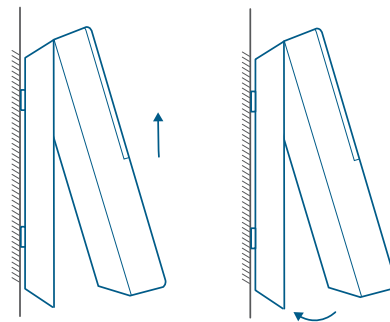

Das war's!

Wenn Sie die Türklingel abnehmen oder aufladen möchten, finden Sie in den folgenden Abschnitten nähere Angaben.

# ANHANG 1 – ABNEHMEN DER TÜRKLINGEL

## Aushängen der Türklingel

1. Verwenden Sie zum Abnehmen der Türklingel von der Montagehalterung den mitgelieferten Lösestift.
2. Drücken Sie mit dem Lösestift in die Öffnung unten an der Türklingel und heben Sie sie anschließend an, um den unteren Teil der Türklingel zu lösen.

Hierzu erforderlich: Türklingel-Lösestift

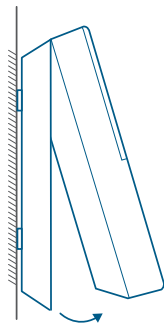
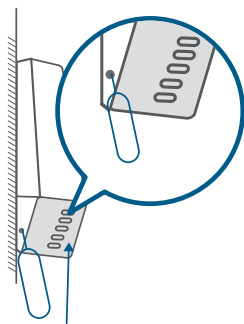
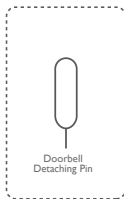

# ANHANG 2 – AUFLADEN DER TÜRKLINGEL

## Die Türklingel aufladen

Laden Sie die Türklingel mit universellen USB-Ladegeräten mit einer Leistungsabgabe von 5V 1A auf.

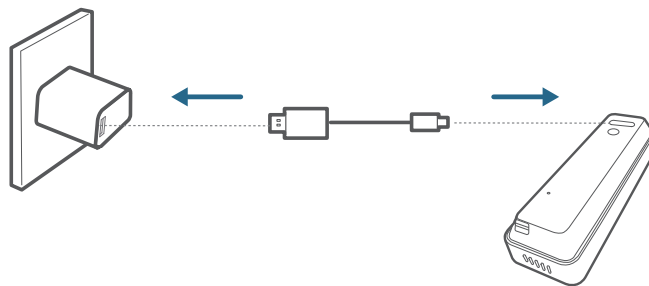

LED-Anzeige	Aufladen: Leuchtet orangefarben
	Vollständig aufgeladen: Leuchtet blau
Ladedauer	In 6 Stunden von 0 % auf 100 %



# TABLA DE CONTENIDOS

Contenido	<b>38</b>	<b>46</b>	Identificación de una ubicación de instalación adecuada
Descripción del producto	<b>40</b>	<b>48</b>	Instalación del soporte
Funcionamiento del sistema	<b>41</b>	<b>51</b>	Instalación del timbre
Encendido del dispositivo sonoro del timbre	<b>42</b>	<b>52</b>	Desmontaje del timbre
Configuración del sistema	<b>44</b>	<b>53</b>	Carga del timbre
Carga del timbre	<b>45</b>	<b>54</b>	Aviso

## Contenido

### Para la instalación del timbre con vídeo



Timbre con vídeo fino (1080p, alimentado por batería)

Model: T8220

Id. de FCC: 2AOKB-T8020  
IC: 23451-T8020

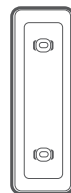

Soporte de montaje



Tarjeta de posicionamiento del orificio para tornillos



Cuña de montaje de 15° (opcional)



Cable de carga USB

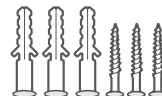

Paquetes de tornillos (con tornillos y tacos de repuesto incluidos)



Clavija de extracción del timbre



GUÍA DE INICIO RÁPIDO

## Para la instalación del dispositivo sonoro del timbre Wi-Fi

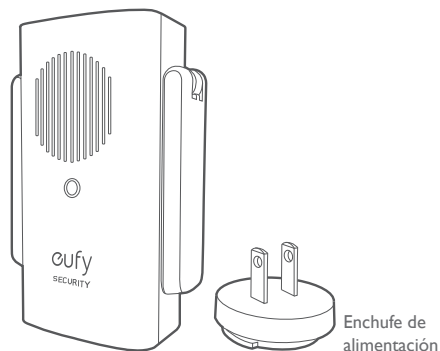

Modelo: Dispositivo sonoro del timbre Wi-Fi  
Id. de FCC: 2AOKB-T8020  
IC: 23451-T8020

Nota: El enchufe de alimentación puede variar en función de la región.

## Descripción del producto

### Timbre con vídeo (alimentado por batería)

Vista frontal:

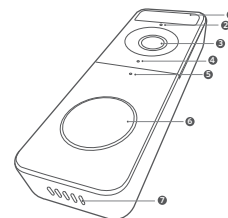

1. Sensor de movimiento
2. Micrófono
3. Lente de la cámara
4. Sensor de luz ambiental
5. LED de estado
6. Botón del timbre
7. Altavoz

Vista posterior:

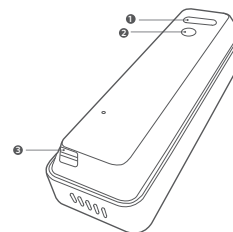

1. Puerto de carga micro-USB
2. Botón Sincronizar/Restablecer
3. Mecanismo de desmontaje

Funcionamiento	Instrucciones
Encendido	Pulse y suelte el botón Sincronizar.
Adición del timbre al dispositivo sonoro del timbre Wi-Fi	Mantenga pulsado el botón Sincronizar hasta que escuche un pitido.
Apagado del timbre	Pulse rápidamente el botón Sincronizar 5 veces en un espacio de 3 segundos.
Restablecimiento del timbre	Mantenga pulsado el botón Sincronizar durante 10 segundos

# Funcionamiento del sistema

## Funcionamiento del sistema

El sistema de timbre con vídeo está compuesto por 2 partes:

- El timbre con vídeo instalado en la puerta
- El dispositivo sonoro del timbre Wi-Fi en el interior de su hogar

El timbre con vídeo detecta cualquier movimiento en la entrada de su hogar y le permite abrir la puerta en cualquier momento y desde cualquier lugar. El dispositivo sonoro del timbre Wi-Fi almacena clips de vídeo en una tarjeta microSD (suministrada por el usuario) y funciona como un dispositivo sonoro digital interno. Cuando alguien llame al timbre, se enviará una notificación a los habitantes de la vivienda.

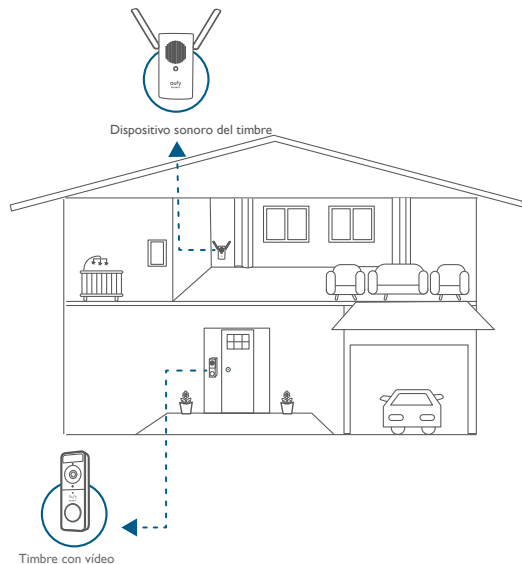

# PASO 1 ENCENDIDO DEL DISPOSITIVO SONORO DEL TIMBRE WI-FI

## Conexión de HomeBase 2 a Internet

1. Instale el conector de alimentación en el dispositivo sonoro del timbre Wi-Fi.
  - ① Coloque el conector de alimentación sobre el dispositivo sonoro del timbre Wi-Fi en la dirección indicada por las flechas.
  - ② Alinee las ranuras elevadas del conector de alimentación con la muesca de la base del dispositivo sonoro del timbre.
  - ③ Gire hacia la derecha para bloquear el conector de alimentación en su lugar.

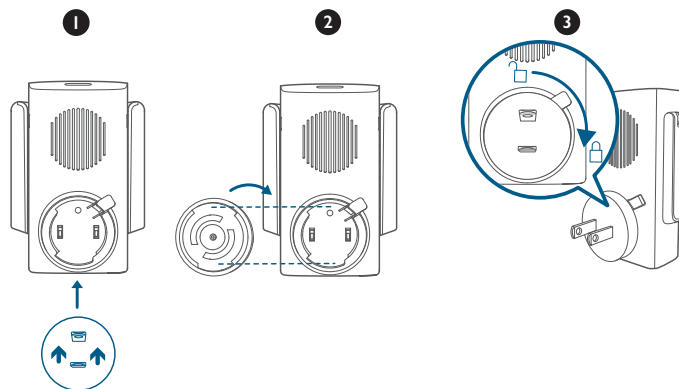

2. Extienda las antenas del dispositivo sonoro del timbre Wi-Fi.

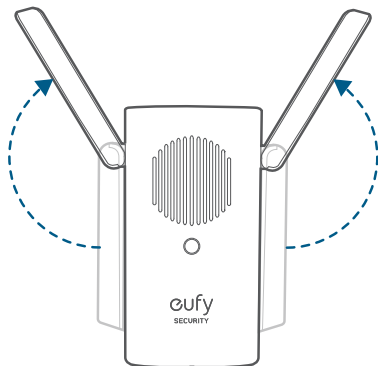

3. Conecte el dispositivo sonoro del timbre Wi-Fi a un suministro de alimentación de CA en la ubicación deseada. El indicador LED se ilumina en color verde fijo cuando el dispositivo sonoro del timbre está listo para la configuración.

## PASO 2: CONFIGURACIÓN DEL SISTEMA

### Descarga de la aplicación y configuración del sistema

Descargue la aplicación eufy Security desde la App Store (dispositivos iOS) o Google Play (dispositivos Android).



Regístrese para crear una cuenta de eufy Security y siga las instrucciones que aparecen en pantalla para completar la configuración.

Toque Añadir dispositivo y añada los siguientes dispositivos:

1. El dispositivo sonoro del timbre Wi-Fi.
2. El timbre.

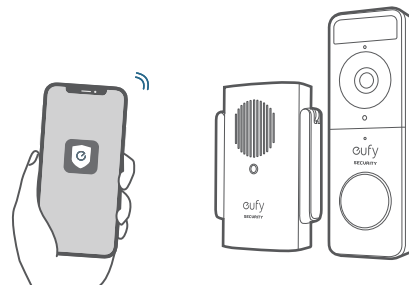

## PASO 3: CARGA DEL TIMBRE

El timbre se envía con un nivel de batería del 80 % para un transporte seguro. Cárguelo completamente antes de instalarlo en la puerta de entrada.

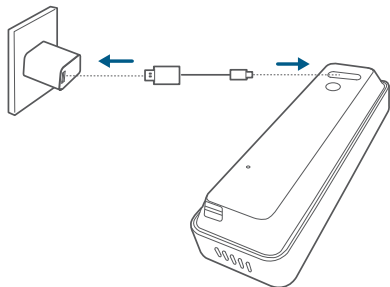

Nota: La duración de la batería varía en función del uso. En condiciones normales, a lo largo de un día pueden llamar al timbre hasta 15 veces y cada grabación dura unos 20 segundos de media. En esta situación, la duración de la batería del timbre puede llegar a los 4 meses.

## PASO 4: IDENTIFICACIÓN DE LA UBICACIÓN DE INSTALACIÓN

### Identificación de una ubicación de instalación adecuada

Salga con el timbre con vídeo a la puerta de entrada y, simultáneamente, compruebe la transmisión en directo disponible en la aplicación eufy Security. Identifique la posición desde la que obtiene el campo de visión deseado.

Tenga en cuenta lo siguiente:

1. Compruebe si es posible reutilizar los orificios y tacos existentes instalados en la pared o el marco de la puerta.
2. Si desea instalar el timbre cerca de una pared lateral, asegúrese de que la pared no sea visible en el campo de visión. De lo contrario, la luz infrarroja se reflejará y la visión nocturna será borrosa.
3. Si va a taladrar los orificios de montaje por primera vez, la altura de instalación recomendada es a 1,2 metros del suelo.
4. Si desea ampliar la visión de un lado específico, utilice la cuña de montaje de 15° como soporte de montaje complementario.

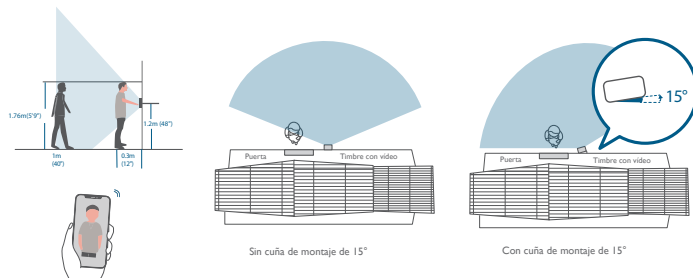

Coloque la tarjeta de posicionamiento del orificio para tornillos en la pared para marcar la ubicación.

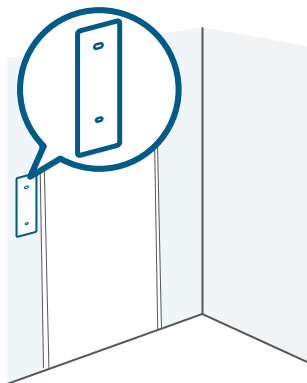

## PASO 5: INSTALACIÓN DEL SOPORTE

### Instalación del timbre en una superficie de madera

Si va a instalar el timbre en una superficie de madera, no es necesario taladrar orificios. Utilice los tornillos suministrados para fijar el soporte de montaje a la pared. La tarjeta de posicionamiento del orificio para tornillos indica la posición de los orificios para tornillos.

**Herramientas necesarias:** Taladro eléctrico, soporte de montaje, cuña de montaje de 15° (opcional) y paquetes de tornillos

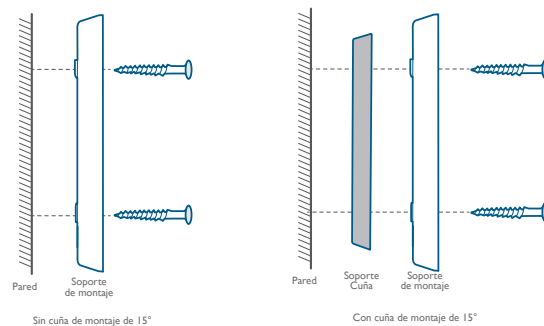
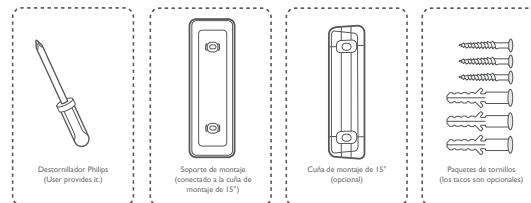

## Instalación del timbre con vídeo en superficies de materiales duros

1. Si va a instalar el timbre en una superficie hecha de materiales duros, como ladrillo, hormigón o estuco, taladre dos orificios a través de la tarjeta de posicionamiento del orificio para tornillos con una broca de 6 mm (15/64").
2. Introduzca los tacos suministrados y, a continuación, utilice los tornillos largos suministrados para fijar el soporte de montaje a la pared.

Herramientas necesarias: Taladro eléctrico, broca de 6 mm (15/64"), soporte de montaje, cuña de montaje de 15° (opcional) y paquetes de tornillos

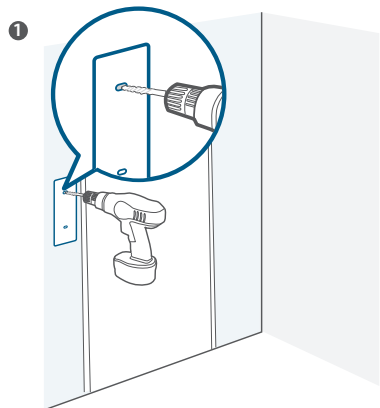
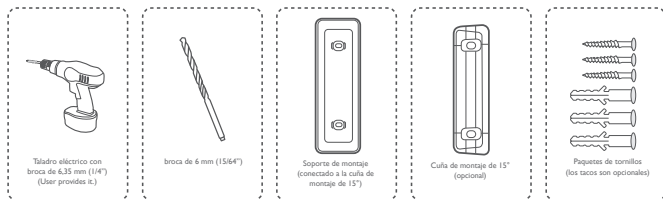

2

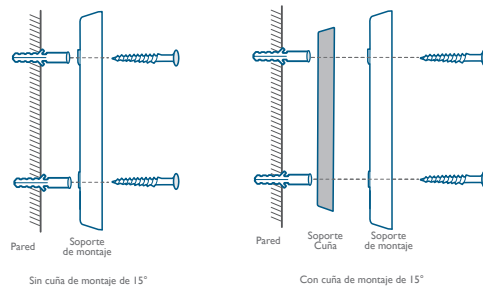

## PASO 6: INSTALACIÓN DEL TIMBRE

### Instalación del timbre

Alinee el timbre con la parte superior del soporte y, a continuación, encaje la parte inferior en su lugar.

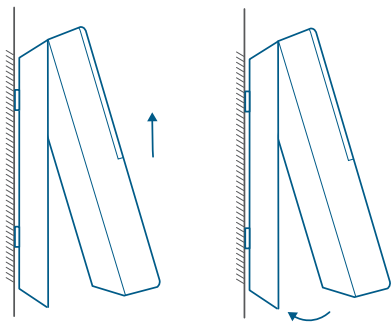

¡Ya está!

Si desea desmontar el timbre para cargar la batería, consulte las secciones siguientes.

## ANEXO I: DESMONTAJE DEL TIMBRE

### Desmontaje del timbre

1. Si desea desmontar el timbre del soporte de montaje, utilice la clavija de extracción del timbre suministrada.
2. Inserte y presione la clavija de extracción en el orificio de la parte inferior del timbre y, a continuación, levante la parte inferior del timbre para extraerlo.

Elementos necesarios: Clavija de extracción del timbre

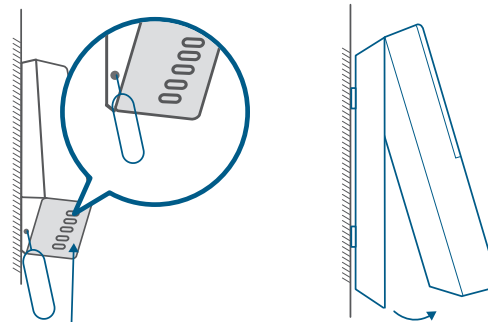
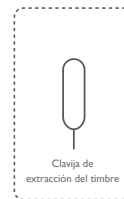



## ANEXO 2: CARGA DEL TIMBRE

### Carga del timbre

Cargue el timbre con un cargador USB universal con una salida de 5 V, 1 A.

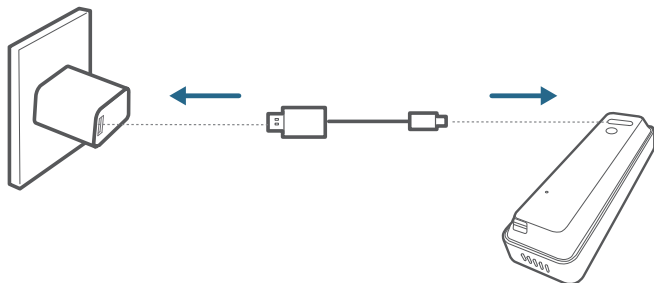

Indicación LED	Carga en curso: naranja fijo
	Carga completa: Azul fijo
Tiempo de carga	6 horas de 0 % a 100 %

## TABLE DES MATIÈRES

CONTENU	55	63	Trouver un emplacement de montage
Présentation du produit	57	65	Montage du support
Fonctionnement du système	58	68	Montage de la sonnette
Mise sous tension du carillon de sonnette Wi-Fi	59	69	Débranchement de la sonnette
Configuration du système	61	70	Rechargement de la sonnette
Chargement de votre sonnette	62	71	Avis

# CONTENU

## Pour l'installation de la sonnette vidéo



Sonnette vidéo mince  
(1080p, alimentée par  
batterie)

Modèle : T8220

FCC ID: 2AOKB-T8220

IC: 23451-T8220



Câble de  
charge USB

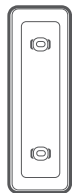

Support de  
montage



Carte de  
positionnement du  
trou de vis



Cale de montage  
15° (facultatif)

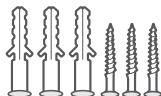

Jeux de vis (vis de  
rechange et ancrages  
inclus)



Goupille  
d'éjection de la  
sonnette



GUIDE DE  
DÉMARRAGE  
RAPIDE

## Pour le montage du carillon de sonnette Wi-Fi

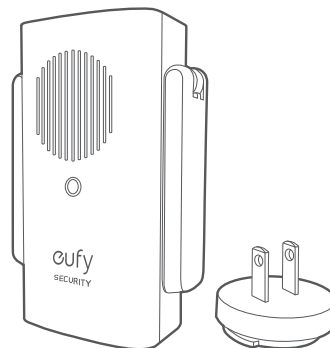

Modèle : Carillon de sonnette Wi-Fi-Prise électrique

Identifiant FCC : 2AOKB-T8020

IC : 23451-T8020

Remarque : la prise de l'adaptateur d'alimentation peut varier selon les régions.

# Présentation du produit

## Sonnette vidéo (alimentée par batterie)

Vue avant :

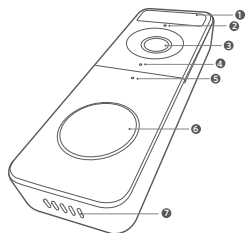

1. Détecteur de mouvement
2. Microphone
3. Objectif de la caméra
4. Détecteur de lumière ambiante
5. LED d'état
6. Bouton de sonnette
7. Haut-parleur

Vue arrière :

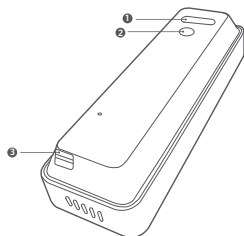

1. Port de charge micro USB
2. Bouton SYNC/RESET
3. Mécanisme de détachement

Fonctionnement	Instructions
En marche	Appuyez et relâchez le bouton SYNC.
Ajouter une sonnette au carillon de sonnette Wi-Fi	Appuyez sur le bouton SYNC et maintenez-le enfoncé jusqu'à ce que vous entendiez un bip.
Mettre la sonnette hors tension	Appuyez rapidement sur le bouton SYNC 5 fois en 3 secondes.
Réinitialiser la sonnette	Appuyez sur le bouton SYNC pendant 10 secondes

# Fonctionnement du système

## Fonctionnement du système

Le système de sonnette vidéo comprend 2 parties :

- La sonnette vidéo sur votre porte
- Le carillon de sonnette Wi-Fi dans votre maison

La sonnette vidéo détecte les mouvements sur votre porche et vous permet de répondre à la porte à tout moment et depuis n'importe où. Le carillon de sonnette Wi-Fi stocke des vidéos sur une carte microSD (fournie par l'utilisateur) et fait office de carillon numérique en intérieur. Lorsque quelqu'un sonne à la porte, les personnes présentes au domicile en sont informées.

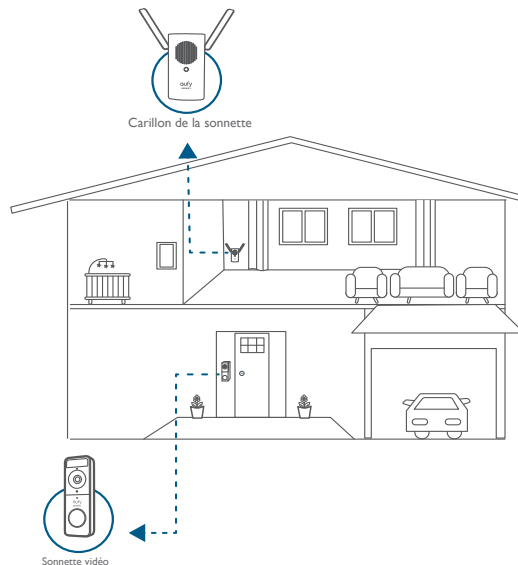

# ÉTAPE I MISE SOUS TENSION DU CARILLON DE SONNETTE WI-FI

## Connecter la station HomeBase 2 à Internet

1. Fixez le connecteur d'alimentation au carillon de sonnette Wi-Fi.
  - ① Placez le connecteur d'alimentation sur le carillon de sonnette Wi-Fi dans le sens indiqué par les flèches.
  - ② Alignez les fentes surélevées du connecteur d'alimentation avec l'encoche sur la base du carillon de sonnette.
  - ③ Tournez dans le sens horaire pour fixer le connecteur d'alimentation en place.

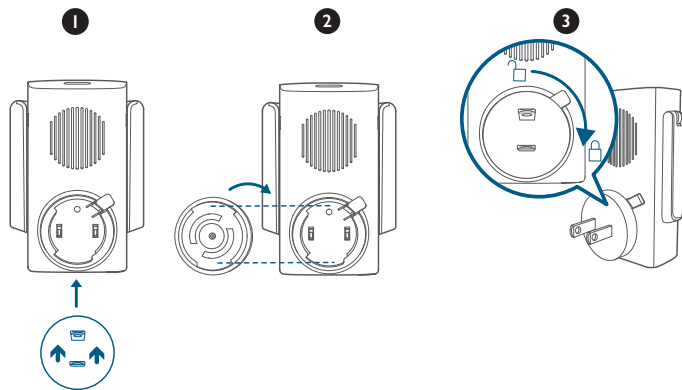

2. Déployez les antennes du carillon de sonnette Wi-Fi.

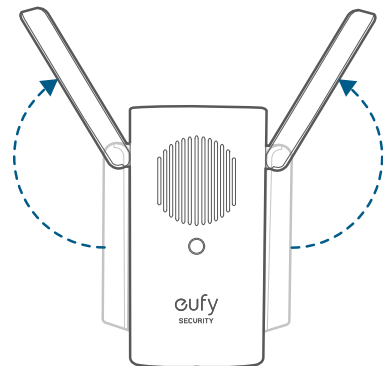

3. Branchez le carillon de sonnette Wi-Fi sur une alimentation secteur en CA à l'endroit souhaité. Le voyant LED devient vert fixe lorsque le carillon de sonnette est prêt à être configuré.

## ÉTAPE 2 CONFIGURATION DU SYSTÈME

### Télécharger l'application et configurer le système

Téléchargez l'application eufy Security sur l'App Store (appareils iOS) ou Google Play (Android).



Créez un compte eufy Security et suivez les instructions à l'écran pour effectuer la configuration.

Appuyez sur Ajouter un appareil et ajoutez les appareils suivants :

1. Ajoutez le carillon de sonnette Wi-Fi.
2. Ajoutez la sonnette.

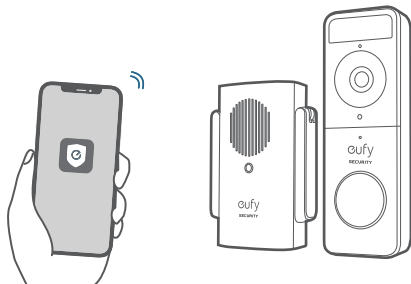

## ÉTAPE 3 CHARGEMENT DE VOTRE SONNETTE

La sonnette est livrée avec un niveau de batterie de 80 % pour un transport en toute sécurité. Chargez-la complètement avant de la monter sur votre porte d'entrée.

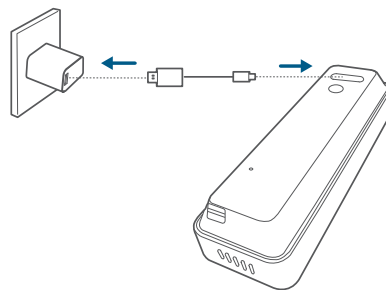

Remarque : la durée de vie de la batterie varie en fonction de l'utilisation. Dans la plupart des cas, une sonnette peut détecter jusqu'à 15 événements par jour et chaque enregistrement dure en moyenne 20 secondes. Dans ce cas de figure, la durée de vie de la batterie de la sonnette peut atteindre 4 mois.

# ÉTAPE 4 RECHERCHE D'UN EMPLACEMENT DE MONTAGE

## Rechercher un emplacement de montage

Emportez la sonnette vidéo à votre porte d'entrée et vérifiez la vue en direct sur l'application eufy Security en même temps. Recherchez un emplacement où vous pouvez obtenir le champ de vision souhaité.

Tenez compte des facteurs ci-dessous :

1. Vérifiez si vous pouvez réutiliser les trous et les ancrages existants sur le mur ou le cadre de la porte.
2. Si vous souhaitez placer la sonnette à proximité d'un mur latéral, assurez-vous que le mur n'apparaît pas dans le champ de vision. Sinon, la lumière infrarouge sera réfléchiée et la vision nocturne sera floue.
3. Si vous percez les trous de montage pour la première fois, la hauteur de montage recommandée est de 1,2 m (48 po) du sol.
4. Utilisez la cale de montage 15° comme support de montage supplémentaire si vous souhaitez avoir une vue élargie sur un côté spécifique.

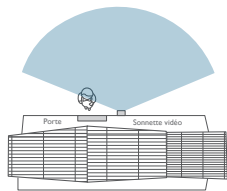
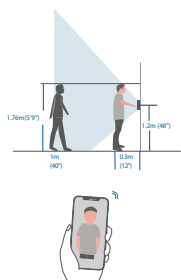

Sans cale de montage 15°

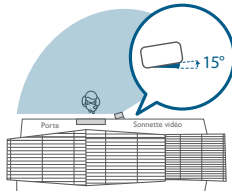

Avec cale de montage 15°

Placez la carte de positionnement de trou de vis contre le mur pour marquer la position.

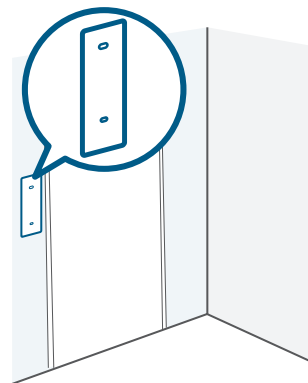

# ÉTAPE 5 MONTAGE DU SUPPORT

## Monter la sonnette sur une surface en bois

Si vous montez la sonnette sur une surface en bois, vous n'avez pas besoin de percer d'avant-trous. Utilisez les vis fournies pour fixer le support de montage au mur. La carte de positionnement de trou de vis indique la position des trous de vis.

**Matériel nécessaire : perceuse électrique, support de montage, cale de montage à 15° (facultatif), jeux de vis**

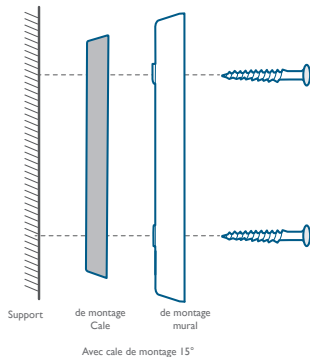
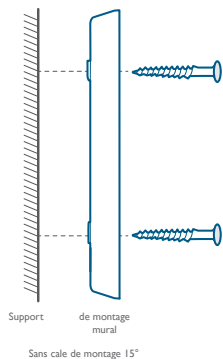
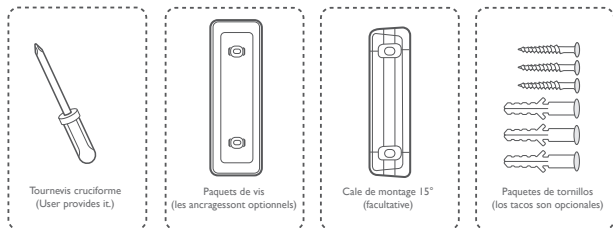

## Monter la sonnette vidéo sur des surfaces en matériaux durs

1. Si vous montez la sonnette sur une surface en matériaux durs, comme de la brique, du béton ou du stuc, percez 2 trous en utilisant la carte de positionnement de trou de vis avec un foret de 6 mm (15/64 po).
2. Insérez les ancrages fournis, puis utilisez les vis longues fournies pour fixer le support de montage au mur.

**Matériel nécessaire : perceuse électrique, foret de 6 mm (15/64 po), support de montage, cale de montage à 15° (facultatif), jeux de vis**

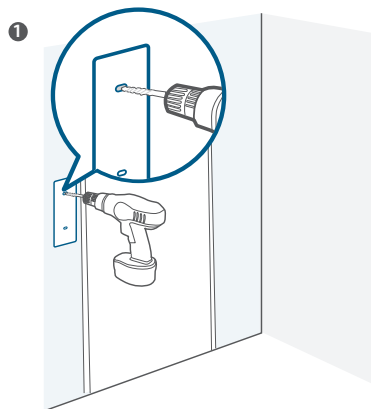
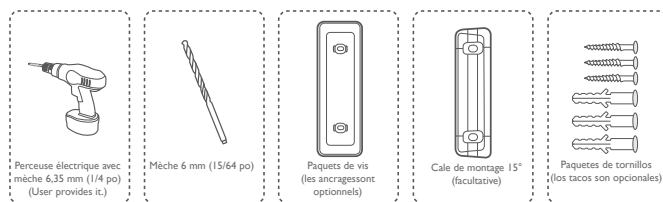

2

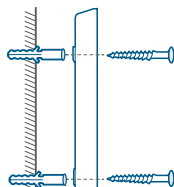

Support de montage mural

Sans cale de montage 15°

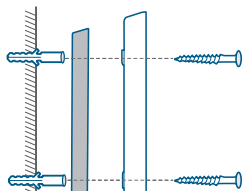

Support de montage mural  
Cale

Avec cale de montage 15°

## ÉTAPE 6 MONTAGE DE LA SONNETTE

### Monter la sonnette

Alignez la sonnette avec le haut du support, puis enclenchez la partie basse à sa place.

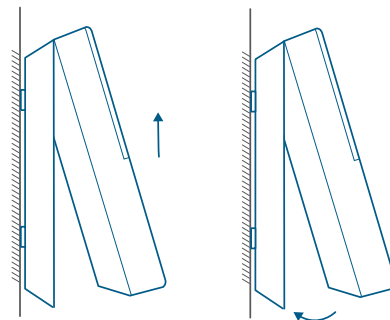

Le montage est terminé.

Si vous souhaitez détacher la sonnette ou la recharger, veuillez vous reporter aux sections suivantes.



# ANNEXE 1 DÉTACHEMENT DE LA SONNETTE

## Détacher la sonnette

1. Utilisez la goupille d'éjection de sonnette fournie si vous souhaitez enlever la sonnette du support de montage.
2. Insérez la goupille d'éjection dans le trou au bas de la sonnette et appuyez, puis soulevez pour retirer le bas de la sonnette.

**Matériel nécessaire : goupille d'éjection de la sonnette**

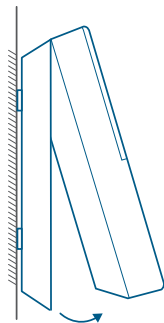
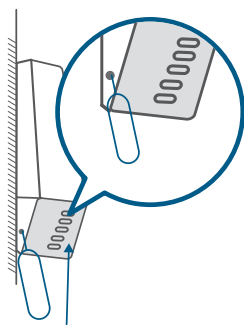
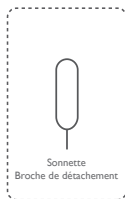

# ANNEXE 2 RECHARGEMENT DE LA SONNETTE

## Recharger la sonnette

Chargez la sonnette à l'aide d'un chargeur USB universel qui fournit une sortie de 5 V 1 A.

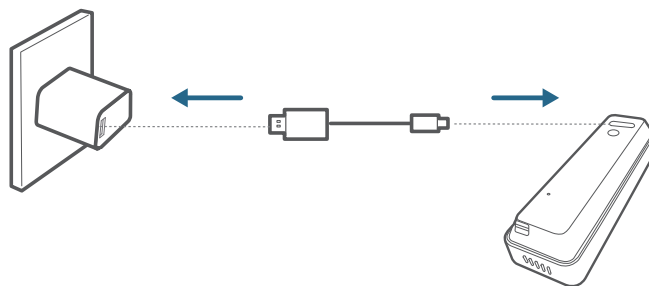

Signification du voyant LED	En charge : orange fixe
	Chargement terminé : bleu fixe
Temps de charge	6 heures de 0 % à 100 %

# INDICE DEI CONTENUTI

CONTENUTO DELLA CONFEZIONE	<b>72</b>	<b>80</b>	Individuazione di un punto di montaggio
Panoramica del prodotto	<b>74</b>	<b>82</b>	Montaggio della staffa
Funzionamento del sistema	<b>75</b>	<b>85</b>	Montaggio del citofono
Alimentazione del citofono Wi-Fi con cicalino	<b>76</b>	<b>86</b>	Rimozione del citofono
Configurazione del sistema	<b>78</b>	<b>87</b>	Ricarica del citofono
Ricarica del citofono	<b>79</b>	<b>88</b>	Avviso

## CONTENUTO DELLA CONFEZIONE

### Per l'installazione del videocitofono



Videocitofono sottile (1080p, Staffa di montaggio alimentato a batteria)  
Modello: T8220

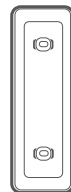

Scheda di posizionamento dei fori per le viti



Cuneo di montaggio da 15° (facoltativo)

ID FCC: 2AOKB-T8220  
IC: 2345 I-T8220



Cavo di ricarica USB

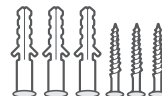

Pacchetti di viti e ancoraggi di ricambio inclusi)



Perno di rimozione del citofono



GUIDA INTRODUTTIVA

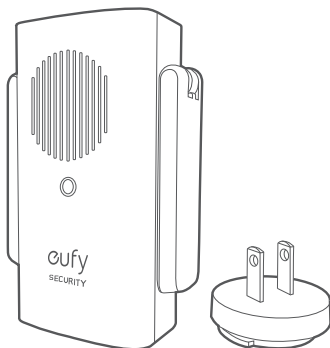

Modello: citofono Wi-Fi con cicalino  
ID FCC: 2AOKB-T8020  
IC: 23451-T8020

Nota: la spina di alimentazione varia in base all'area geografica di riferimento.

## Panoramica del prodotto

### Videocitofono (alimentato a batteria)

Vista anteriore:

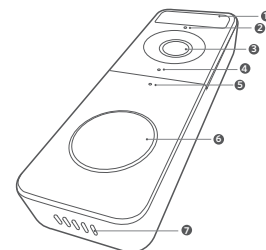

1. Sensore di movimento
2. Microfono
3. Obiettivo telecamera
4. Sensore di luce ambiente
5. LED di stato
6. Pulsante citofono
7. Altoparlante

Vista posteriore:

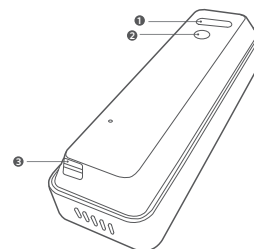

1. Porta di ricarica Micro-USB
2. Pulsante SYNC/RESET (SINC/RIPRISTINO)
3. Meccanismo di rimozione

Funzionamento	Modalità
Accensione	Premere e rilasciare il pulsante SYNC (SINC).
Aggiunta del citofono Wi-Fi con cicalino	Tenere premuto il pulsante SYNC (SINC) fino a sentire un segnale acustico.
Spegnimento del citofono	Premere rapidamente il pulsante SYNC (SINC) per 5 volte in 3 secondi.

Ripristino del citofono

Tenere premuto il pulsante SYNC (SINC) per 10 secondi.

## Funzionamento del sistema

### Funzionamento del sistema

Il sistema videocitofono comprende 2 parti:

- Una corrispondente al videocitofono collocato in prossimità della porta d'ingresso.
- Una corrispondente al citofono Wi-Fi con cicalino nell'abitazione.

Il videocitofono rileva i movimenti all'ingresso di casa e consente all'utente di rispondere in qualsiasi momento e ovunque si trovi. Il citofono Wi-Fi con cicalino archivia i videoclip su una scheda microSD (fornita dall'utente) e funziona come un segnale acustico interno. Quando qualcuno preme il citofono, le persone che si trovano in casa verranno avvisate.

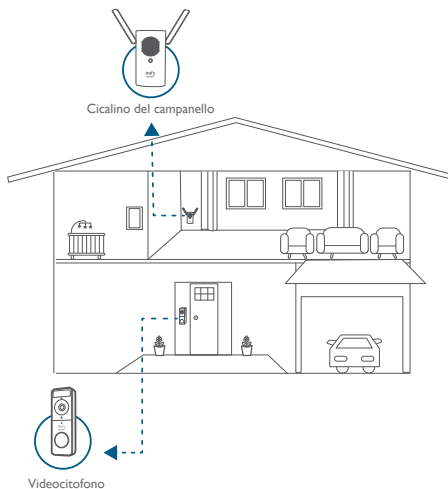

## PASSAGGIO 1: ALIMENTAZIONE DEL CICALINO DEL CITOFONO WI-FI

### Connessione di HomeBase 2 a Internet

1. Fissare il connettore di alimentazione al citofono Wi-Fi con cicalino.

- ① Posizionare il connettore di alimentazione sul citofono Wi-Fi con cicalino nella direzione indicata dalle frecce.
- ② Allineare le fessure sollevate del connettore di alimentazione con la tacca sulla base del citofono con cicalino.
- ③ Ruotare in senso orario per bloccare il connettore di alimentazione in posizione.

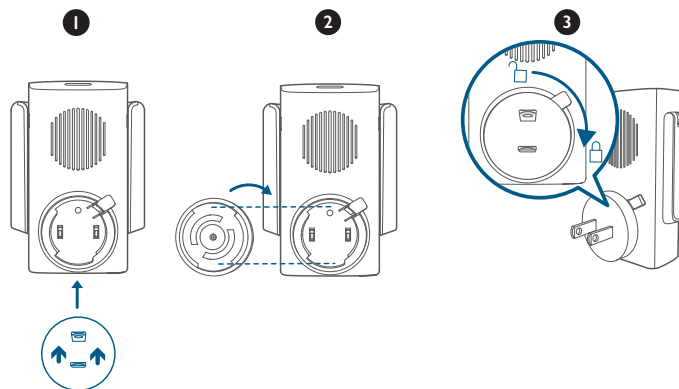

2. Spiegare le antenne del citofono Wi-Fi con cicalino.

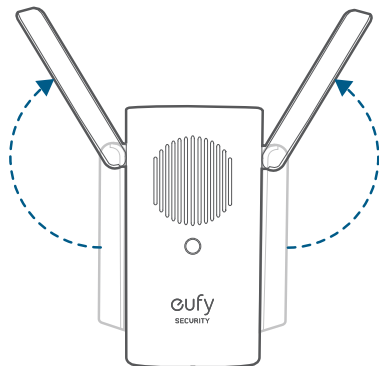

3. Collegare il citofono Wi-Fi con cicalino a una fonte di alimentazione CA nella posizione desiderata. L'indicatore LED diventa verde fisso quando il citofono con cicalino è pronto per l'installazione.

## PASSAGGIO 2 CONFIGURAZIONE DEL SISTEMA

### Download dell'app e configurazione del sistema

Scaricare l'app eufy Security dall'App Store (dispositivi iOS) o da Google Play (dispositivi Android).



Registrare il proprio account eufy Security e seguire le istruzioni visualizzate per completare la configurazione.

Toccare Aggiungi dispositivo e aggiungere i seguenti dispositivi:

1. Aggiungere il citofono Wi-Fi.
2. Aggiungere il citofono.

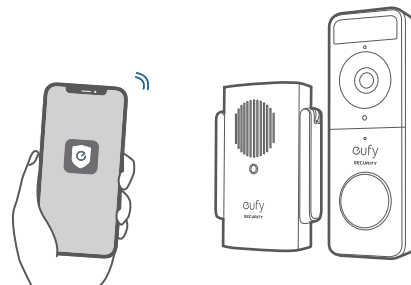

## PASSAGGIO 3 RICARICA DEL CITOFONO

Il citofono viene fornito con un livello di carica della batteria dell'80% per un trasporto sicuro. Ricaricare completamente prima di montare il citofono sulla porta d'ingresso.

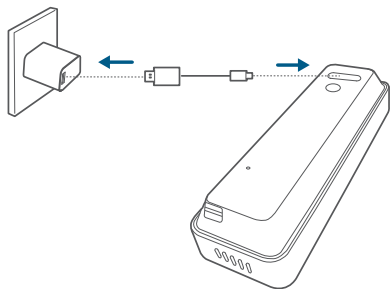

Nota: l'autonomia della batteria varia in base all'utilizzo. Nella maggior parte dei casi, il citofono viene utilizzato per un massimo di 15 volte al giorno e ciascuna registrazione ha una durata media di 20 secondi. In tale scenario, l'autonomia della batteria del citofono può durare fino a 4 mesi.

## PASSAGGIO 4 SELEZIONE DI UN PUNTO PER IL MONTAGGIO

### Individuazione di un punto di montaggio

Portare il videocitofono in prossimità della porta d'ingresso e, contemporaneamente, controllare la visualizzazione in tempo reale sull'app eufy Security. Individuare la posizione più idonea, con un buon campo visivo.

Considerare i seguenti fattori:

1. Verificare se i fori e gli ancoraggi esistenti sulla parete o sul telaio della porta possano essere riutilizzati.
2. Se si desidera posizionare il citofono vicino a una parete laterale, assicurarsi che questa non occupi il campo visivo. In caso contrario, la luce IR si rifletterà e la visuale notturna risulterà offuscata.
3. Se si praticano i fori di montaggio per la prima volta, l'altezza raccomandata da terra è di 1,2 m.
4. Utilizzare il cuneo di montaggio da 15° come staffa di montaggio supplementare se si desidera avere una visualizzazione più ampia su un lato specifico.

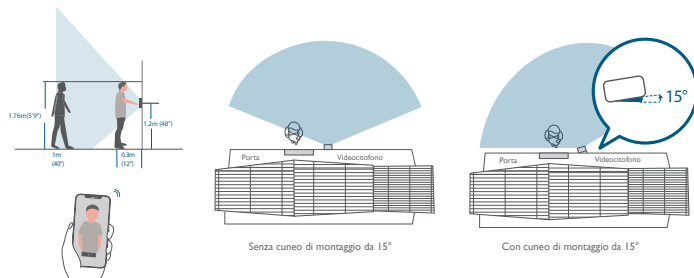

Collocare la scheda di posizionamento dei fori per le viti contro la parete per contrassegnare la posizione di montaggio.

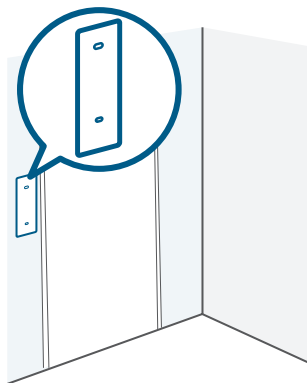

## PASSAGGIO 5 MONTAGGIO DELLA STAFFA

### Montaggio del citofono su una superficie lignea

In caso di montaggio del citofono su una superficie lignea, non occorre praticare dei prefori. Utilizzare le viti in dotazione per fissare la staffa di montaggio alla parete. La scheda di posizionamento dei fori per le viti indica la posizione dei fori per le viti.

**Attrezzi richiesti:** trapano elettrico, staffa di montaggio, cuneo di montaggio da 15° (facoltativo), pacchetti di viti

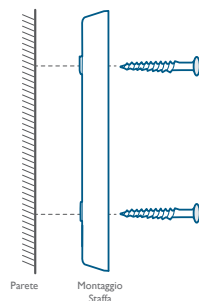
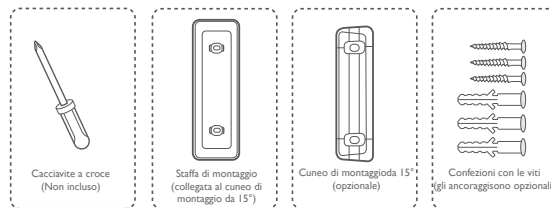

Senza cuneo di montaggio da 15°

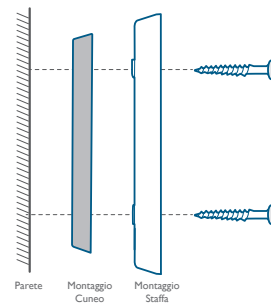

Con cuneo di montaggio da 15°

## Montaggio del videocitofono su superfici in materiale duro

1. Se si decide di installare il citofono su una superficie in materiale duro come mattoni, calcestruzzo o stucco, praticare 2 fori usando la scheda di posizionamento dei fori per le viti con una punta da 6 mm.
2. Inserire gli ancoraggi in dotazione e utilizzare le viti lunghe per fissare la staffa di montaggio alla parete.

**Attrezzi richiesti:** trapano elettrico, punta da 6 mm, staffa di montaggio, cuneo di montaggio da 15° (facoltativo), pacchetti di viti

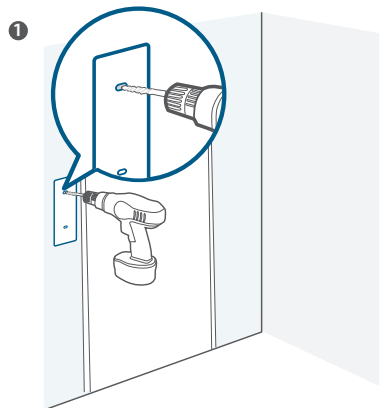
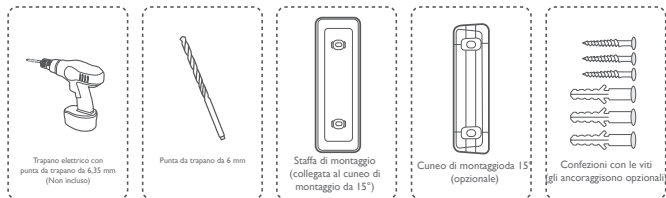

2

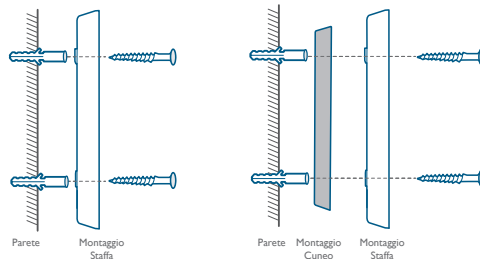

Senza cuneo di montaggio da 15°

Con cuneo di montaggio da 15°



# PASSAGGIO 6 MONTAGGIO DEL CITOFONO

## Montaggio del citofono

Allineare il citofono con la parte superiore del supporto, quindi far scattare la parte inferiore in posizione.

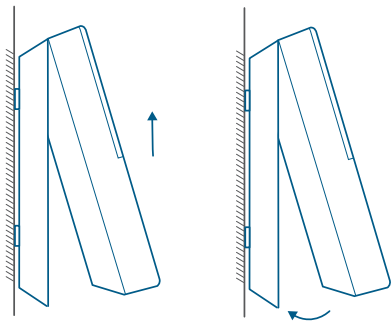

Il montaggio è terminato!

Se si desidera rimuovere il citofono o ricaricarlo, fare riferimento alle sezioni seguenti.

# APPENDICE I RIMOZIONE DEL CITOFONO

## Rimozione del citofono

1. Utilizzare il perno di rimozione del citofono fornito in dotazione se si desidera staccare il citofono dalla staffa di montaggio.
2. Inserire e premere il perno di distacco nel foro nella parte inferiore del citofono, quindi sollevare per rimuovere la parte inferiore del citofono.

Attrezzi richiesti: Perno di rimozione del citofono

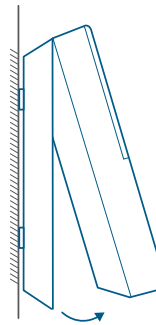
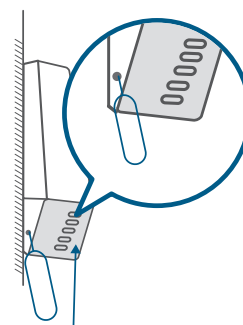
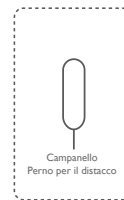

## APPENDICE 2 RICARICA DEL CITOFONO

### Ricarica del citofono

Ricaricare il citofono con caricatori USB universali che forniscono energia in uscita pari a 5V deute "e"! A.

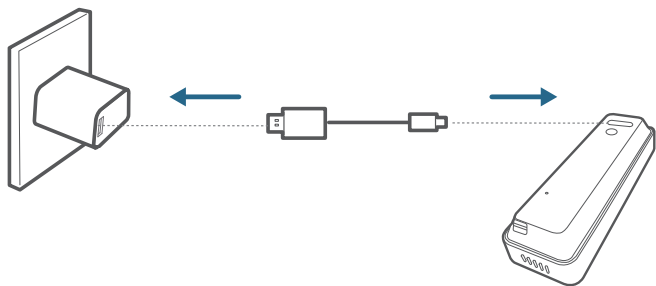

Spia LED	In carica: arancione fisso
	Ricarica completata: Blu fisso
Durata della ricarica	6 ore da 0% a 100%

## INHOUDS- OPGAVE

WAT ZIT ER IN DE DOOS?	89	97	Een geschikte montageplek vinden
Productoverzicht	91	99	De beugel monteren
De werking van het systeem	92	102	De deurbel monteren
De wifi-deurbelgong inschakelen	93	103	De deurbel loskoppelen
Het systeem instellen	95	104	De deurbel opladen
Uw Deurbel opladen	96	105	Kennisgeving

# WAT ZIT ER IN DE DOOS?

## Voor de installatie van de videodeurbel



Video Doorbell Slim  
(1080p, op batterijen)  
Model: T8220

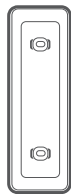

Montagebeugel



Positioneringskaart  
voor schroefgaten



15° montagegwig  
(optioneel)

FCC-ID: 2AOKB-T8020  
IC: 23451-T8020



USB-oplaadkabel

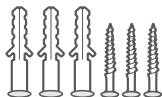

Schroefpakketten  
(reserveschroeven en  
-pluggen meegeleverd)



Ontgrendelingspin  
voor de deurbel



SNELSTARTGIDS

## Voor de installatie van de wifi-deurbelgong



Model: Wifi-deurbelgong  
FCC-ID: 2AOKB-T8020  
IC: 23451-T8020

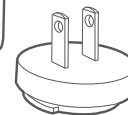

Stekker

Opmerking: De stekker kan per regio verschillen.

# Productoverzicht

## Videodeurbel (op batterijen)

Voorraanzicht:

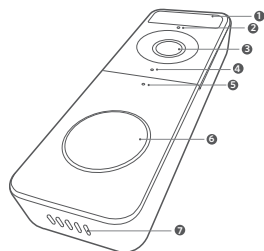

1. Bewegingsensor
2. Microfoon
3. Cameralens
4. Omgevingslichtsensor
5. Status-led
6. Deurbelknop
7. Luidspreker

Achteraanzicht:

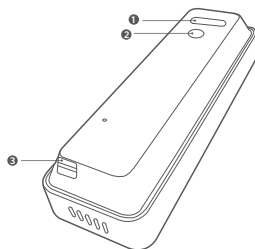

1. Micro-USB-oplaadpoort
2. SYNC/RESET-knop
3. Loskoppelmechanisme

Bediening	Instructies
Inschakelen	Druk op de SYNC-knop.
Deurbel toevoegen aan wifi-deurbelgong	Houd de SYNC-knop ingedrukt totdat u een pieptoon hoort.
De deurbel uitschakelen	Druk binnen 3 seconden snel 5 keer op de SYNC-knop.
De deurbel resetten	Houd de SYNC-knop 10 seconden ingedrukt.

# De werking van het systeem

## De werking van het systeem

Het videodeurbelsysteem bestaat uit 2 delen:

- De videodeurbel bij uw deur
- De wifi-deurbelgong in uw huis

De videodeurbel detecteert beweging op uw veranda en stelt u in staat de deur altijd en overal te open te doen. De wifi-deurbelgong slaat videoclips op een microSD-kaart (niet meegeleverd) op en werkt als een digitale gong binnenshuis. Als iemand aanbelt, krijgen de mensen in huis een melding.

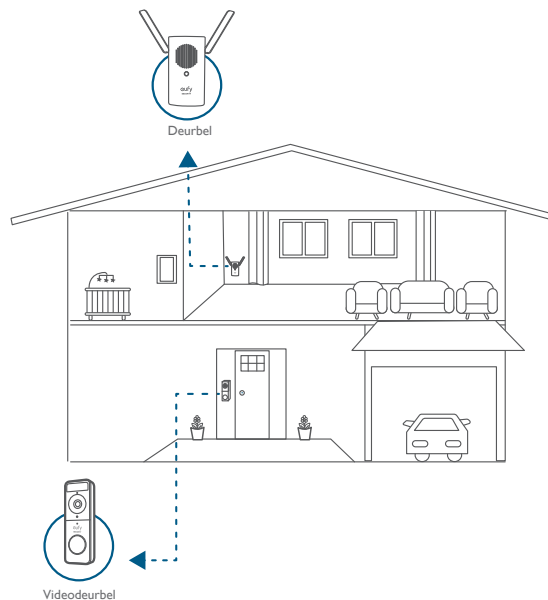

# STAP 1 DE WIFI-DEURBELGONG INSCHAKELEN

## De HomeBase 2 verbinden met het internet

1. Bevestig de voedingsconnector op de wifi-deurbelgong.
  - ① Plaats de voedingsconnector in de richting van de pijlen op de wifi-deurbelgong.
  - ② Lijn de verhoogde sleuven van de voedingsconnector uit met de inkeping op de voet van de deurbelgong.
  - ③ Draai met de klok mee om de voedingsconnector op zijn plaats te vergrendelen.

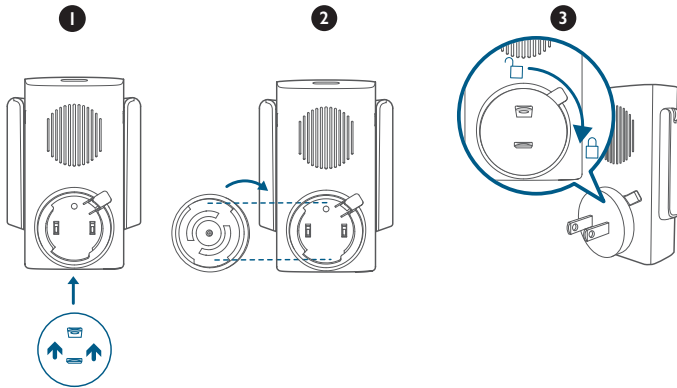

2. Klap de antennes van de wifi-deurbelgong uit.

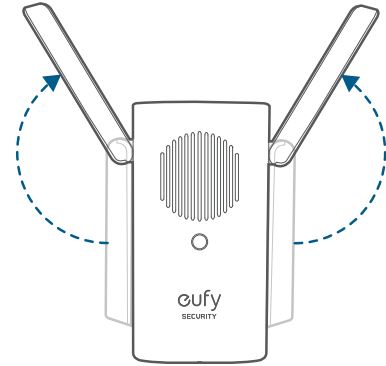

3. Steek de stekker van de wifi-deurbelgong in een stopcontact op de gewenste locatie. Het led-indicatielampje wordt groen wanneer de deurbelgong klaar is voor de installatie.

## STAP 2 HET SYSTEEM INSTELLEN

### De app downloaden en het systeem instellen

Download de eufy Security-app uit de App Store (iOS-apparaten) of Google Play (Android-apparaten).



Meld u aan voor een eufy Security-account en volg de instructies op het scherm om de installatie te voltooien.

Tik op Apparaat toevoegen en voeg de volgende apparaten toe:

1. Voeg de wifi-deurbelgong toe.
2. Voeg de deurbel toe.

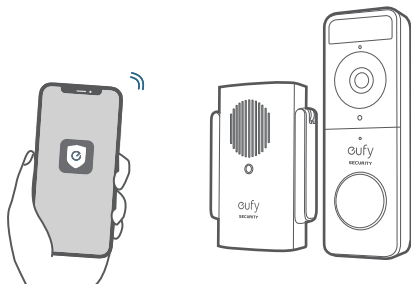

## STAP 3 UW DEURBEL OPLADEN

De deurbel wordt geleverd met een batterijniveau van 80%, zodat deze veilig kan worden getransporteerd. Laad de deurbel volledig op voordat u deze bij uw voordeur monteert.

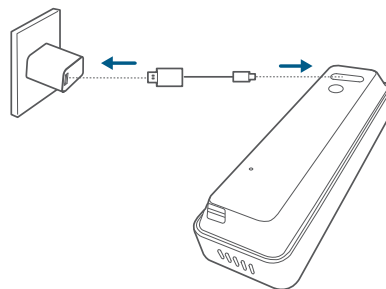

Opmerking: De batterijduur is afhankelijk van het gebruik. In de meest voorkomende gevallen kan een deurbel tot 15 gebeurtenissen per dag vastleggen, waarbij elke opname gemiddeld 20 seconden duurt. In dit scenario is de batterijduur maximaal 4 maanden.

# STAP 4 EEN GESCHIKTE MONTAGEPLEK VINDEN

## Een geschikte montageplek vinden

Neem de videodeurbel mee naar uw voordeur en bekijk tegelijkertijd de liveweergave in de eufy Security-app. Zoek een plaats die u het gewenste gezichtsveld biedt.

Houd rekening met de onderstaande factoren:

1. Controleer of u de bestaande gaten en pluggen in de muur of het deurkozijn kunt hergebruiken.
2. Als u de deurbel dicht bij een zijmuur wilt plaatsen, zorgt u ervoor dat de muur niet in het gezichtsveld verschijnt. Anders wordt IR-licht gereflecteerd en wordt nachtzicht wazig.
3. Als u de montagegaten voor het eerst boort, is de aanbevolen montagehoogte 1,2 meter vanaf de grond.
4. Als u meer wilt zien aan een specifieke zijde, gebruikt u de 15° montagewig als extra montagebeugel.

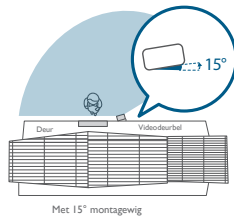
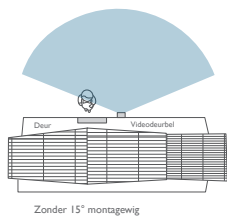
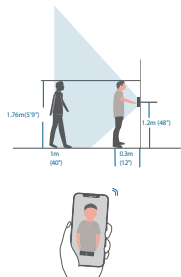

Plaats de positioneringskaart voor schroefgaten tegen de muur om de positie te markeren.

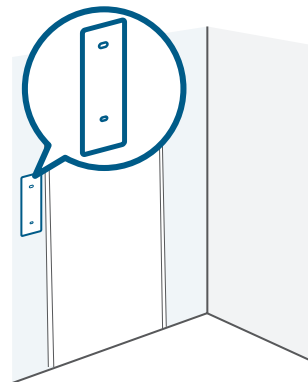

# STAP 5 DE BEUGEL MONTEREN

## De deurbel monteren op een houten oppervlak

Als u de deurbel op een houten oppervlak monteert, hoeft u geen boorgaten voor te boren. Gebruik de meegeleverde schroeven om de montagebeugel aan de muur te bevestigen. De positioneringskaart voor schroefgaten geeft de positie van de schroefgaten aan.

**Wat u nodig hebt: boormachine, montagebeugel, 15° montagewig (optioneel), schroefpakketten**

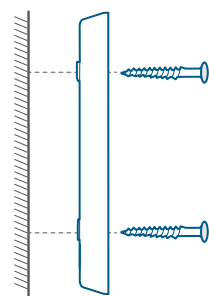
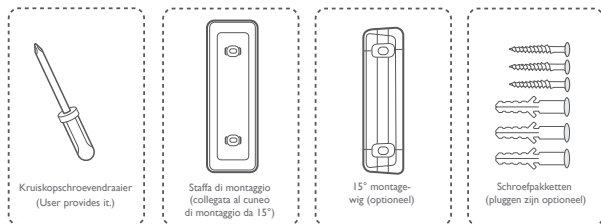

Muur Montagebeugel  
Zonder 15° montagewig

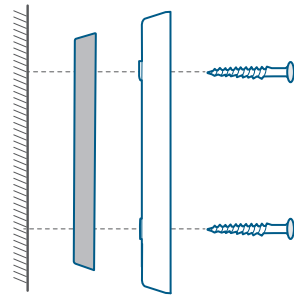

Muur MontageWig Montagebeugel  
Met 15° montagewig

## De videodeurbel monteren op oppervlakken gemaakt van harde materialen

1. Als u de deurbel monteert op een oppervlak dat is gemaakt van harde materialen, zoals baksteen, beton of stucwerk, gebruikt u een boortje van 6 mm om 2 gaten door de positioneringskaart voor schroefgaten te boren.
2. Steek de meegeleverde pluggen in de gaten en gebruik vervolgens de meegeleverde lange schroeven om de montagebeugel aan de muur te bevestigen.

**Wat u nodig hebt: boormachine, boortje van 6mm, montagebeugel, 15° montagewig (optioneel), schroefpakketten**

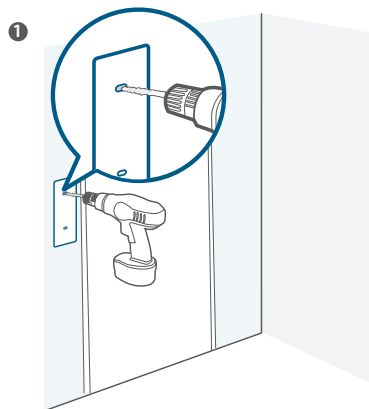
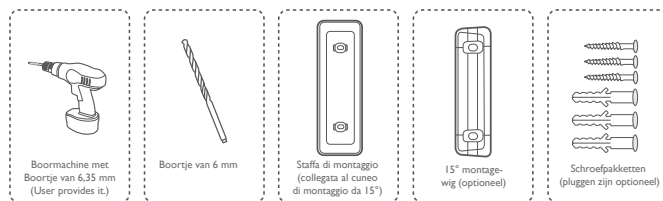



2

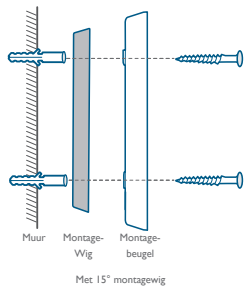
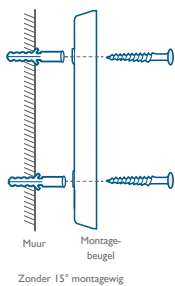

## STAP 6 DE DEURBEL MONTEREN

### De deurbel monteren

Lijn de deurbel uit met de bovenkant van de houder en klik de onderkant op zijn plaats.

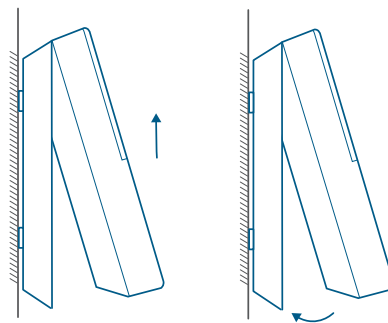

**U bent klaar!**

Als u de deurbel wilt loskoppelen of wilt opladen, raadpleegt u de volgende delen van deze handleiding.

# BIJLAGE I DE DEURBEL LOSKOPPELEN

## De deurbel loskoppelen

1. Gebruik de meegeleverde ontgrendelingspin voor de deurbel als u de deurbel los wilt koppelen van de montagebeugel.
2. Steek de ontgrendelingspin in het gat aan de onderkant van de deurbel en til de onderkant van de deurbel vervolgens op om deze van de beugel te halen.

Wat u nodig hebt: ontgrendelingspin voor de deurbel

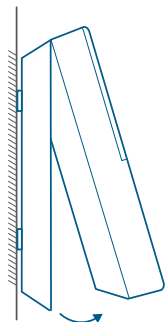
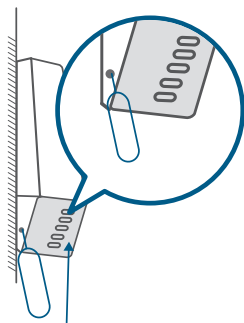
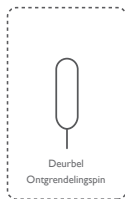

# BIJLAGE 2 DE DEURBEL OPLADEN

## De deurbel opladen

Laad de deurbel op met universele USB-opladers met een uitgangsvermogen van 5 V en 1 A.

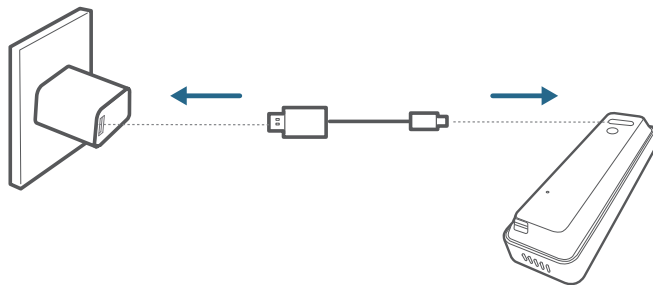

Led-indicatie	Opladen: brandt oranje
	Volledig opgeladen: brandt blauw
Oplaadtijd	6 uur van 0% tot 100%

# ÍNDICE CONTEÚDO

Está incluído	106	114	Encontrar um local para a instalação
DESCRIÇÃO DO PRODUTO	108	116	Instalar o suporte
Como funciona o sistema	109	119	Instalar a campainha
Ligar a campainha por Wi-Fi	110	120	Remover a campainha
Configurar o sistema	112	121	Recarregar a campainha
Carregar a sua campainha	113	122	Informação

## Está incluído

### Para a instalação do Videoporteiro



Videoparteiro Slim (1080p,  
a bateria)  
Modelo:T8220

ID da FCC: 2AOKB-T8020  
IC: 2345 I-T8020

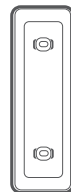

Suporte de  
instalação



Cartão de  
posicionamento  
dos orifícios para  
parafuso



Cunha de  
instalação de 15°  
(opcional)



Cabo de  
carregamento USB

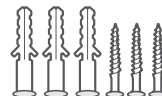

Pacotes de parafusos  
(parafusos e âncoras  
sobressalentes incluídos)



Pino de remoção  
da campainha



Guia de início  
rápido

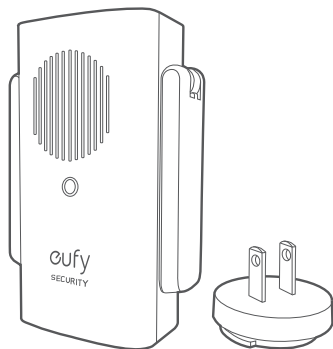

Modelo: Campainha por Wi-Fi    Ficha de alimentação  
ID da FCC: 2AOKB-T8020  
IC: 23451-T8020

Nota: A ficha de alimentação poderá variar consoante as regiões diferentes.

## DESCRIÇÃO DO PRODUTO

### Videoporteiro (A bateria)

Parte da frente:

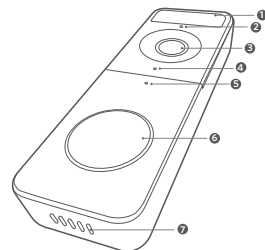

1. Sensor de movimento
2. Microfone
3. Lente da câmara
4. Sensor de luz ambiente
5. LED de estado
6. Botão da campainha
7. Altifalante

Parte de trás:

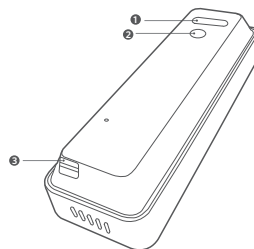

1. Porta de carregamento micro-USB
2. Botão SYNC/RESET
3. Retirar o mecanismo

Operação	Como fazer
Ligar	Prima e liberte o botão SYNC.
Adicionar uma campainha à campainha por Wi-Fi	Prima continuamente o botão SYNC até ouvir um aviso sonoro.
Desligue a campainha	Prima rapidamente 5 vezes o botão SYNC dentro de 3 segundos.

Repor a campainha

Prima continuamente o botão SYNC durante 10 segundos.

## Como funciona o sistema

### Como funciona o sistema

O sistema de videoporteiro inclui 2 partes:

- O videoporteiro na sua porta
- A campainha por Wi-Fi na sua casa

O videoporteiro deteta movimento na sua entrada e permite-lhe atender a porta em qualquer altura e em qualquer lugar. A campainha por Wi-Fi armazena cliques de vídeo num cartão microSD (fornecido pelo utilizador) e funciona com uma campainha digital interior. Quando alguém toca à campainha, as pessoas dentro de casa serão notificadas.

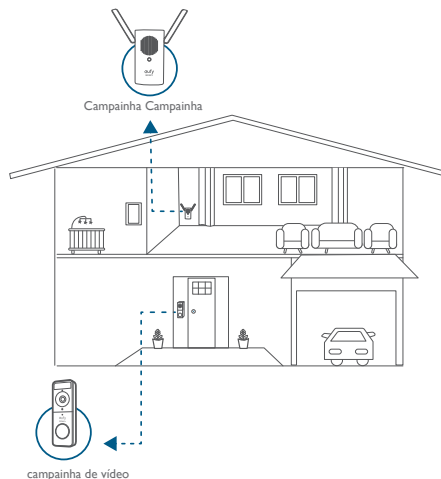

## PASSO I LIGAR A CAMPAINHA POR Wi-Fi

### Ligar a HomeBase 2 à Internet

1. Fixe o conector de alimentação à Campainha por Wi-Fi.

- ① Coloque o conector de alimentação por cima da Campainha por Wi-Fi na direção indicada pelas setas.
- ② Alinhe as aletas elevadas no conector de alimentação com o entalhe na base da campainha.
- ③ Rode no sentido dos ponteiros do relógio para trancar o conector de alimentação.

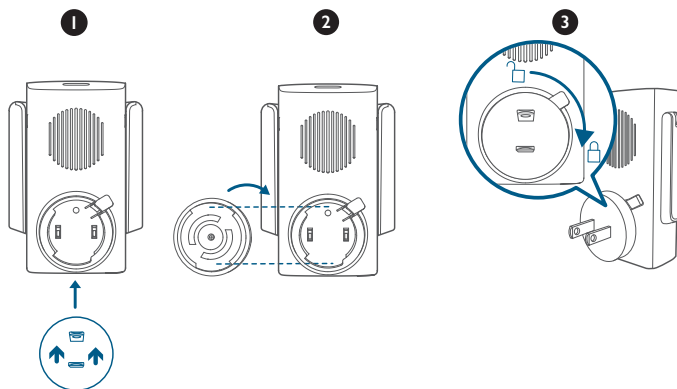

2. Suba as antenas da Campinha por Wi-Fi.

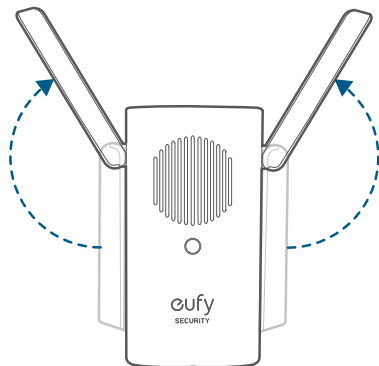

3. Ligue a Campinha por Wi-Fi numa tomada de CA no local pretendido. O indicador LED acende a verde sólido quando a campinha está preparada para a configuração.

## PASSO 2 CONFIGURAR O SISTEMA

### Transferir a aplicação e configurar o sistema

Transfira a aplicação Eufy Security a partir da App Store (dispositivos iOS) ou da Google Play (dispositivos Android).



Registe uma conta Eufy Security e siga as instruções no ecrã para concluir a configuração.

Toque em Adicionar dispositivo e adicione os seguintes dispositivos:

1. Adicione a Campinha por Wi-Fi.
2. Adicione o tom da campinha.

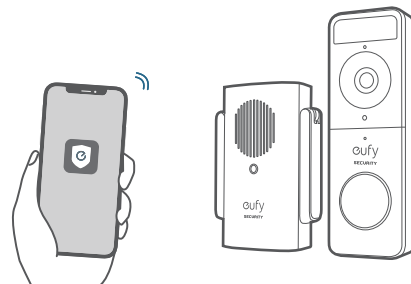

## PASSO 3 CARREGAR A CAMPAINHA

A campainha é fornecida com 80% do nível de bateria para um transporte seguro. Carregue-a totalmente antes de instalar a campainha na porta da frente.

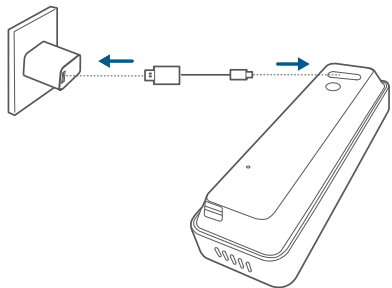

Nota: A duração da bateria varia consoante a utilização. Na maioria dos casos comuns, uma campainha poderá ter até 15 eventos por dia, e cada gravação dura cerca de 20 segundos. Neste cenário, a duração da bateria da campainha pode ser até 4 meses.

## PASSO 4 ENCONTRAR UM LOCAL PARA A INSTALAÇÃO

### Encontrar um local para a instalação

Leve o Teleporteiro para a porta da frente e, ao mesmo tempo, verifique a visualização em direto na aplicação Eufy Security. Encontre uma posição de onde consiga obter o campo de visão pretendido.

Considere os fatores abaixo:

1. Verifique se pode reutilizar os orifícios e âncoras existentes na parede ou na moldura da porta.
2. Se quiser colocar a campainha junto a uma parede lateral, certifique-se de esta não aparece no campo de visão. Caso contrário, a luz de IV poderá ser refletida e a visão noturna tornar-se-á desfocada.
3. Se perfurar os orifícios de instalação pela primeira vez, a altura de instalação recomendada é de 1,2 m de altura do chão.
4. Utilize o calço de instalação como suporte de instalação adicional se quiser ver mais de um lado específico.

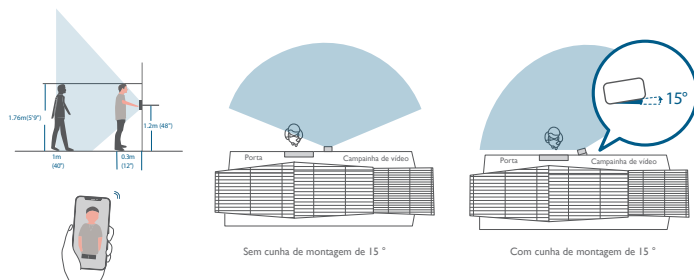

Coloque o cartão de posicionamento de orifícios para parafusos contra a parede para marcar a posição.

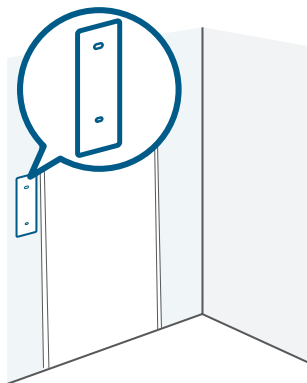

## PASSO 5 INSTALAR O SUPORTE

### Instalar a campainha numa superfície de madeira

Se estiver a instalar a campainha numa superfície de madeira, não precisa perfurar antecipadamente os orifícios piloto. Utilize os parafusos fornecidos para fixar o Suporte de instalação à parede. O Cartão de posicionamento dos orifícios para parafuso indica a posição dos orifícios para os parafusos.

O que é necessário: Broca elétrica, Suporte de instalação, Cunha de instalação de 15° (opcional), conjuntos de parafusos

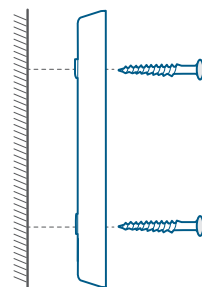
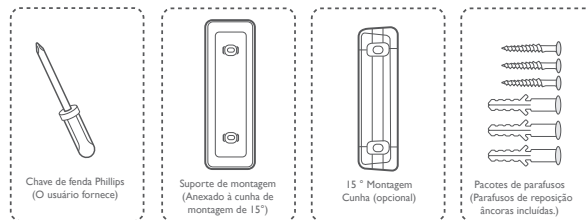

Parade Suporte de montagem

Sem cunha de montagem de 15°

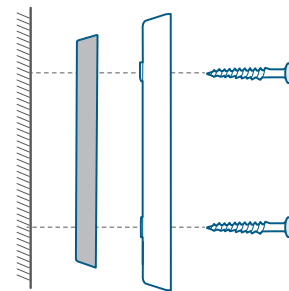

Parade Cunha de montagem Suporte de montagem

Com cunha de montagem de 15°



## Instalar o Teleporteiro em superfícies fabricadas em materiais duros

1. Se estiver a instalar a campainha numa superfície fabricada num material duro, como tijolo, betão, estuque, perfure 2 orifícios com a ajuda do Cartão de posicionamento de orifícios para parafuso com uma broca de 6 mm.
2. Insira as âncoras fornecidas e, em seguida, utilize os parafusos compridos para fixar o Suporte de instalação à parede.

O que é necessário: Broca elétrica (6mm), Suporte de instalação, Cunha de instalação de 15° (opcional), pacotes de parafusos

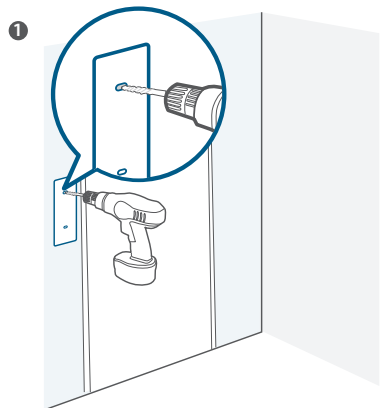
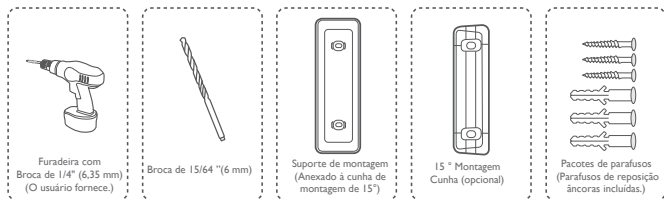

2

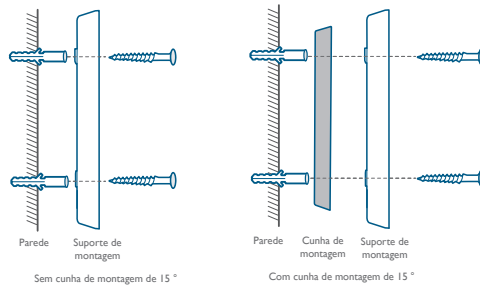

## PASSO 6 INSTALAR A CAMPAINHA

### Instalar a campainha

Alinhe a campainha com a parte de cima do suporte e, em seguida, encaixe a parte de baixo.

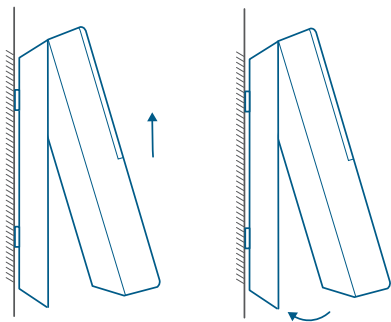

Está pronta!

Se quiser remover a campainha ou recarregá-la, consulte as seguintes secções.

## ANEXO I REMOVER A CAMPAINHA

### Remover a campainha

1. Utilize o pino de remoção da campainha fornecido se quiser remover a campainha do suporte de instalação.
2. Insira e pressione o pino de remoção no orifício que se encontra na parte de baixo da campainha e, em seguida, levante para retirar a parte de baixo da campainha.

O que é necessário: Pino de remoção da campainha

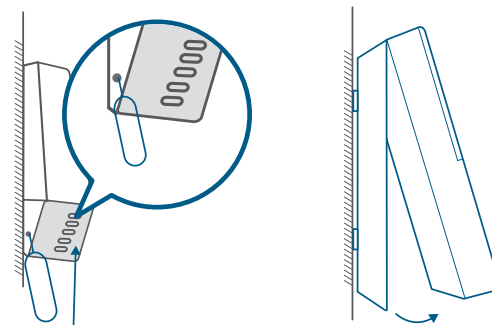
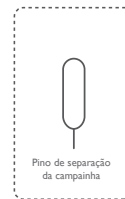

## ANEXO 2 RECARREGAR A CAMPAINHA

### Recarregar a campainha

Carregue a campainha com carregadores USB universais que fornecem uma saída de 5V 1 A.

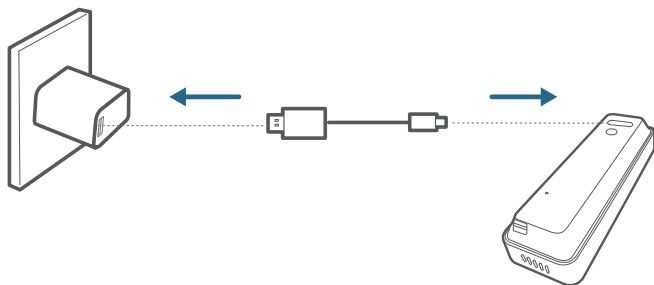

Indicação LED	A carregar: Laranja sólido
	Totalmente carregada: Azul sólido
Tempo de carregamento	6 horas de 0% a 100%

## جدول المحتويات

اللوازم المضمنة	23	31	بيكيتل عقوم ىلع روثغلا
نظرة عامة على المنتج	25	33	تركيب الكتيفة
كيف يعمل النظام	26	34	تركيب جرس الباب
تشغيل رنين جرس الباب بتقنية Wi-Fi	27	36	فصل جرس الباب
إعداد النظام	29	37	إعادة شحن جرس الباب
شحن جرس الباب	30	38	ملاحظة

لتثبيت جرس الباب بتقنية الفيديو



جرس باب نحيف بتقنية الفيديو  
(1080 بكسل، يعمل ببطارية)  
الموديل: T8220

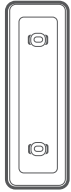

كتيفة التركيب



بطاقة تحديد موضع فتحة  
البرغي



إسفين تركيب 15°  
(اختياري)

رقم تعريف هيئة الاتصالات الفيدرالية: 2AOKB-T8220  
IC: 23451-T8220



كابل الشحن USB

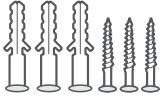

مجموعات البراغي (البراغي  
البديلة والمثبتات مدرجة)



قابس الطاقة



دليل البدء السريع  
ديوس فصل جرس  
الباب

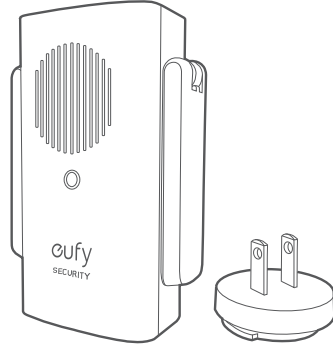

لموديل: رنين جرس الباب بتقنية Wi-Fi  
رقم تعريف هيئة الاتصالات الفيدرالية:  
2AOKB-T8020  
IC: 23451-T8020

ملاحظة: قد يتباين قابس الطاقة في مناطق مختلفة.

كيف يعمل النظام

يشتمل نظام جرس الباب بتقنية الفيديو على جزأين:

- جرس الباب بتقنية الفيديو مثبت على الباب الخاص بك
  - رنين جرس الباب بتقنية Wi-Fi مثبت في منزلك
- يكشف جرس الباب بتقنية الفيديو الحركة في الشرفة الخاصة بك ويسمح لك بفتح الباب في أي وقت وفي أي مكان. يُخزّن رنين جرس الباب بتقنية Wi-Fi مقاطع الفيديو على بطاقة microSD (يوفرها المستخدم) ويعمل كرنين رقمي داخلي. عندما يرن شخص ما جرس الباب، سيتم إخطار الأشخاص المتواجدين في المنزل.

جرس الباب بتقنية الفيديو (يعمل ببطارية)

المنظر الأمامي:

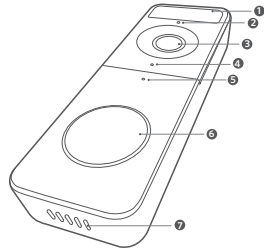

1. حساس الحركة
2. ميكروفون
3. عدسة الكاميرا
4. مستشعر الضوء
5. مؤشر DEL للحالة
6. زر جرس الباب
7. مكبر صوت

المنظر الخلفي:

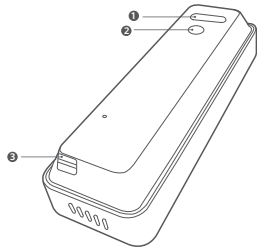

1. منفذ شحن orciM
2. زر المزامنة/إعادة الضبط
3. آلية الفصل

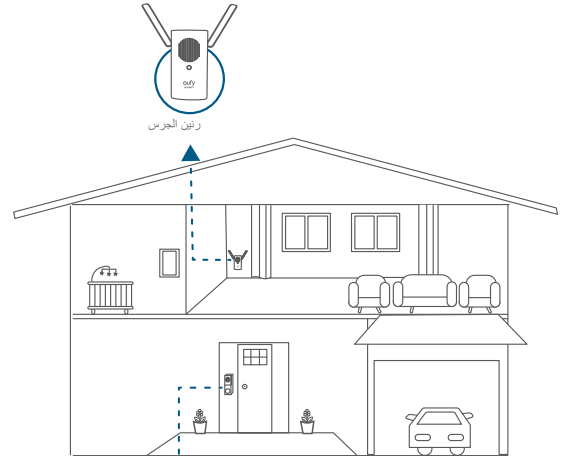

مدرجلا نهجند

التشغيل	كيفية
التشغيل	اضغط على زر المزامنة وحرره.
إضافة جرس الباب إلى رنين جرس الباب بتقنية Wi-Fi	اضغط مطولاً على زر المزامنة حتى تسمع صوتاً.
أوقف تشغيل جرس الباب	اضغط سريعاً على المزامنة 5 مرات لمدة 3 ثوانٍ.
أعد ضبط جرس الباب	اضغط مطولاً على زر المزامنة لمدة 10 ثوانٍ.

## الخطوة 1 تشغيل رنين جرس الباب بتقنية Wi-Fi

### توصيل HomeBase 2 بالإنترنت

- ① تحتاج إلى إصلاح موصل البطاقة برنين جرس الباب بتقنية Wi-Fi.
- ② ضع موصل الطاقة فوق رنين الباب بتقنية Wi-Fi في الاتجاه الذي تشير إليه الأسهم.
- ③ قم بمحاذاة الفتحات المرتفعة لموصل الطاقة مع القطع العلوي الموجود على قاعدة رنين جرس الباب.
- ④ قم بالتدوير في اتجاه عقارب الساعة لقفل موصل الطاقة في مكانه.

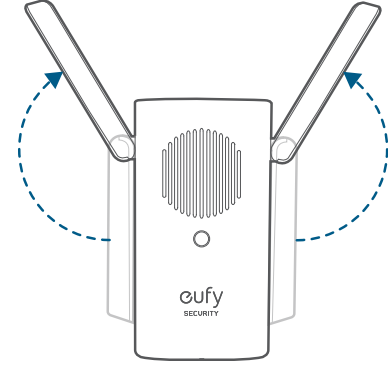
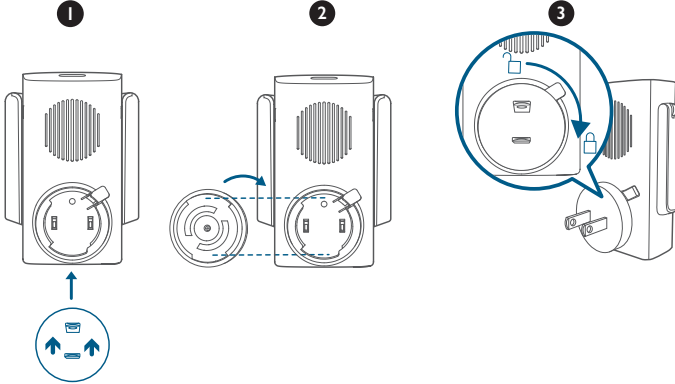

قم بتوصيل رنين جرس الباب بتقنية Wi-Fi بمصدر طاقة التيار المتردد في الموقع الذي تريده. يتحول مؤشر LED إلى اللون الأخضر الثابت عندما يكون رنين جرس الباب جاهزًا للإعداد.

## الخطوة 3 شحن جرس الباب

يتوفر جرس الباب ببطارية ممتلئة بنسبة 80% للنقل الآمن. اشحنه بالكامل قبل تثبيت جرس الباب عند الباب الأمامي.

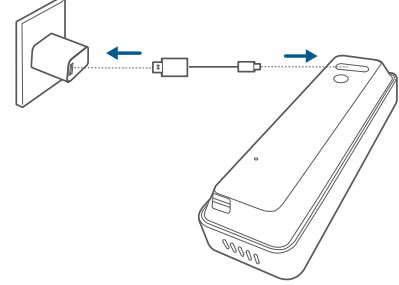

ملاحظة: يختلف عمر البطارية حسب الاستخدام. في معظم الحالات الشائعة، قد يصل حجم الأحداث التي يتفاعل معها جرس الباب يوميًا إلى 15 أحداث ويستمر كل تسجيل لمدة 20 ثانية في المتوسط. بموجب هذا السيناريو، يمكن أن يدوم عمر بطارية جرس الباب لمدة تصل إلى 4 أشهر.

## الخطوة 2 إعداد النظام

### تنزيل التطبيق وإعداد النظام

يمكنك تنزيل تطبيق eufy Security من App Store (للأجهزة التي تعمل بنظام iOS) أو من Google Play (للأجهزة التي تعمل بنظام Android).



اشترك لإنشاء حساب eufy Security، وأتبع التعليمات التي تظهر على الشاشة لإكمال عملية الإعداد. اضغط على إضافة جهاز وأضف الأجهزة التالية:

1. أضف رنين جرس الباب بتقنية Wi-Fi.
2. أضف جرس الباب.

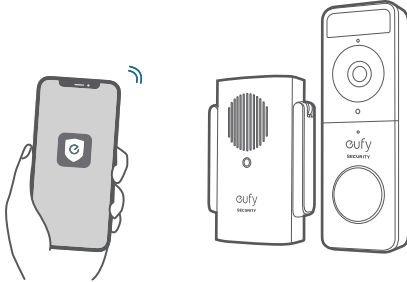

## الخطوة 4 العثور على موقع للتركيب

### العثور على موقع للتركيب

قم بتثبيت جرس الباب بتقنية الفيديو في الباب الأمامي وتحقق من العرض المباشر في تطبيق eufy Security في نفس الوقت. اكتشف مكاناً يُمكنك من خلاله الحصول على مجال الرؤية المطلوب.

قم بمراعاة العوامل التالية:

1. تحقق مما إذا كان يمكنك إعادة استخدام الثقوب والمثبتات الموجودة على الجدار أو إطار الباب.
2. إذا كنت ترغب في وضع جرس الباب بالقرب من الجدار الجانبي، فتأكد من عدم ظهور الجدار في مجال الرؤية. وإلا سوف ينعكس ضوء الأشعة تحت الحمراء وتصبح الرؤية الليلية ضبابية.
3. إذا كنت تقوم بعمل فتحات التركيب لأول مرة، فإن ارتفاع التركيب الموصى به هو 48 بوصة / 1.2 متر من الأرض.
4. استخدم إسفين التركيب 15° ككثيفة تركيب إضافية إذا كنت ترغب في رؤية المزيد على جانب معين.

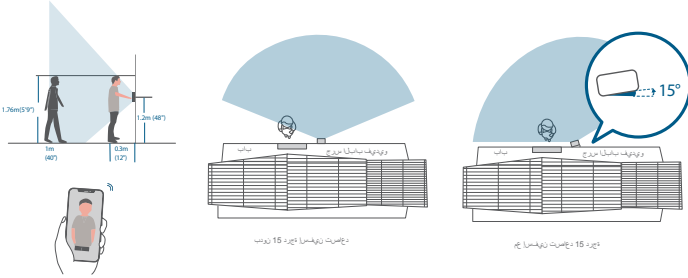

ضع بطاقة تحديد موضع فتحة البرغي على الجدار لتمييز الموضع.

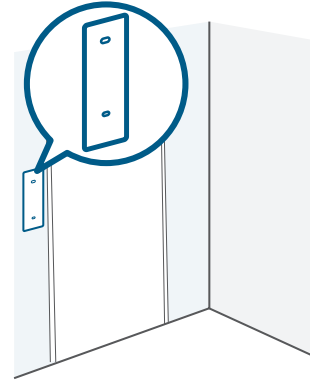



## الخطوة 5 تركيب الكتيفة

### قم بتركيب جرس الباب على سطح خشبي

إذا كنت تقوم بتركيب جرس الباب على سطح خشبي، فلن تحتاج إلى عمل فتحات تجريبية مسبقاً. استخدم البراغي المتوفرة لتثبيت كتيفة التركيب على الجدار. تشير بطاقة تحديد موضع فتحة البرغي إلى موضع فتحات البرغي.

ما هو المطلوب: مثقاب آلي وكتيفة تركيب وإسفين تركيب 15° (اختياري) ومجموعات براغي

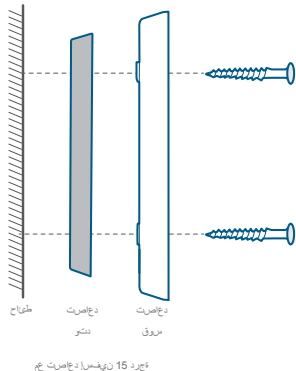
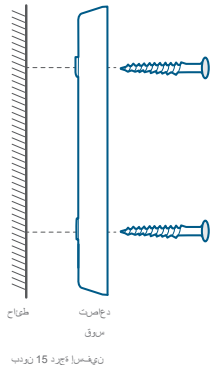
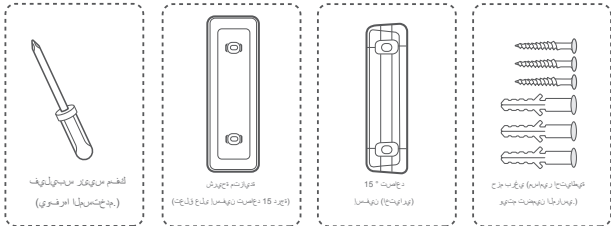

## قم بتركيب جرس الباب بتقنية الفيديو على الأسطح المصنوعة من المواد الصلبة

إذا كنت تقوم بتركيب جرس الباب على سطح مصنوع من مواد صلبة، مثل الطوب والخرسانة والجص، فقم بعمل فتحتين من خلال بطاقة تحديد موضع فتحة البرغي بلقمة مثقاب 15/64 بوصة (6 مم).

قم بوضع المثبتات المرفقة، ثم استخدم البراغي الطويلة المزودة لتركيب كتيفة التركيب على الجدار.

ما هو المطلوب: مثقاب آلي ولقمة مثقاب 15/64 بوصة (6 مم) وكتيفة تركيب وإسفين تركيب 15° (اختياري) ومجموعات براغي

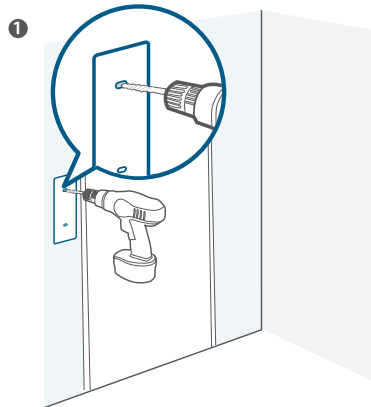
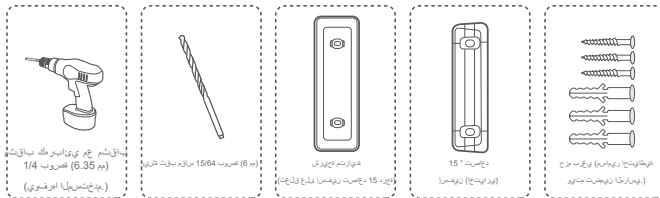

### تركيب جرس الباب

قم بمحاذاة جرس الباب مع الجزء العلوي من كثيفة التركيب ثم ثبت الجزء السفلي في مكانه.

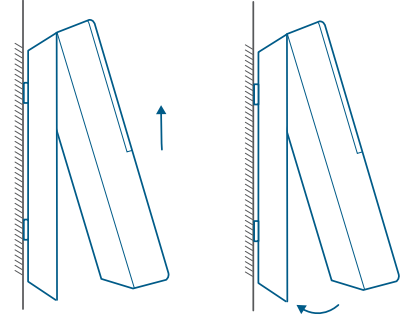

كل شيء جاهز للعمل!

إذا كنت تريد فصل جرس الباب أو إعادة شحنه، يرجى الرجوع إلى الأقسام التالية.

2

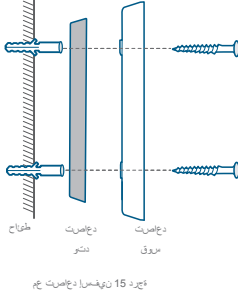
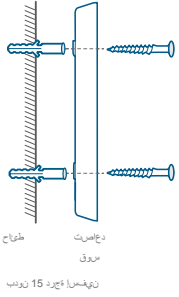

## قم بإعادة شحن جرس الباب

اشحن جرس الباب بشواحن USB عامة توفر خرجًا بجهد 5 فولت 1 أمبير.

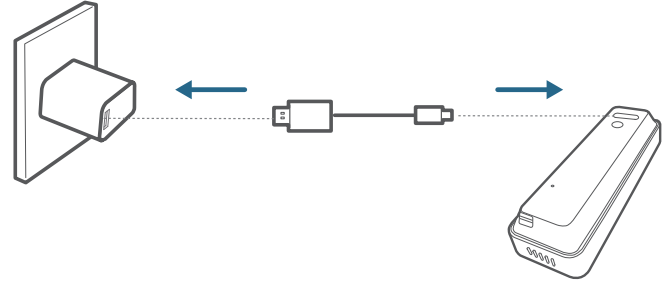

الشحن: برتقالي ثابت	
مؤشر LED	اكتمال الشحن: ضوء أزرق ثابت
مدة الشحن	تحتاج البطارية إلى 6 ساعات للشحن بنسبة 100%

## افصل جرس الباب

استخدم دبوس فصل جرس الباب المرفق إذا كنت ترغب في فصل جرس الباب عن كثيفة التركيب. أدخل دبوس الفصل واضغط عليه في الفتحة الموجودة أسفل جرس الباب ثم ارفعه لإخراج الجزء السفلي من جرس الباب.

ما هو المطلوب: دبوس فصل جرس الباب

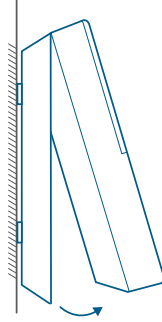
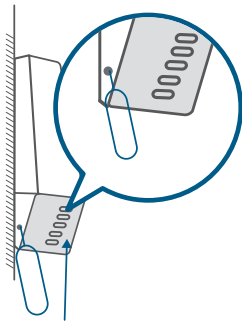
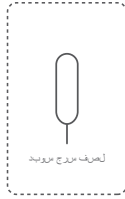

# CUSTOMER SERVICE

## Warranty

12-month limited warranty



12 Monate eingeschränkte Garantie | Garantia limitada de 12 meses  
Garantie limitée de 12 mois | Garanzia limitata di 12 mesi | 12 maanden  
beperkte garantie

12 meses de garantia limitada | ضمان محدود لمدة 12 شهرًا

(US) +1 (800) 988 7973 Mon-Fri 9:00-17:00 (PT)

(UK) + 44 (0) 1604 936 200 Mon-Fri 6:00-11:00 (GMT)

(DE) +49 (0) 69 9579 7960 Mon-Fri 6:00-11:00



+971 42463266 (Middle East & Africa) Sun-Thu 9:00 - 17:30 (GMT+4)

+971 8000320817 (UAE) Sun-Thu 9:00 - 17:30 (GMT+4)

+966 8008500030 (KSA) Sun-Thu 8:00 - 16:30 (GMT+3)

+965 22069086 (Kuwait) Sun-Thu 8:00 - 16:30 (GMT+3)



Customer Support: [support@eufylife.com](mailto:support@eufylife.com)

Anker Innovations Limited

Room 1318-19, Hollywood Plaza, 610 Nathan Road, Mongkok, Kowloon,  
Hong Kong



@EufyOfficial



@EufyOfficial



eufyofficial