

Surface-Mounted Door Speaker (with unlighted pushbutton)

MODEL: ISB-64

For use with NuTone Radio-Intercom Systems (except IM-2003 Series)

This Door Speaker features “Hands-Free” operation.

LOCATION AND MOUNTING

Refer to Figure 1.

1. The speaker should be installed near the door at a convenient height for easy access to the door signal pushbutton.
2. Locate speaker far enough from adjacent surfaces to allow installation of top and bottom speaker housing mounting screws.
3. Pull speaker and pushbutton wire through hole in base plate and secure plate to wall surface with screws provided.

NOTE: On masonry wall, drill appropriate holes and install plastic anchors.

WIRING

1. Remove pushbutton from door speaker housing by exerting pressure from rear of pushbutton.
2. Connect previously installed wires from chime to pushbutton terminals. See Figures 2 and 3. Reinsert pushbutton into speaker housing.
3. Connect previously run wiring from intercom master unit to speaker terminal strip. See Figures 2 and 3.

NOTE: Pushbutton may stick when the terminal screws are tightened fully down without wires being connected. The button insert will release and work properly when screws are loosened and wiring is connected.

FIGURE 1

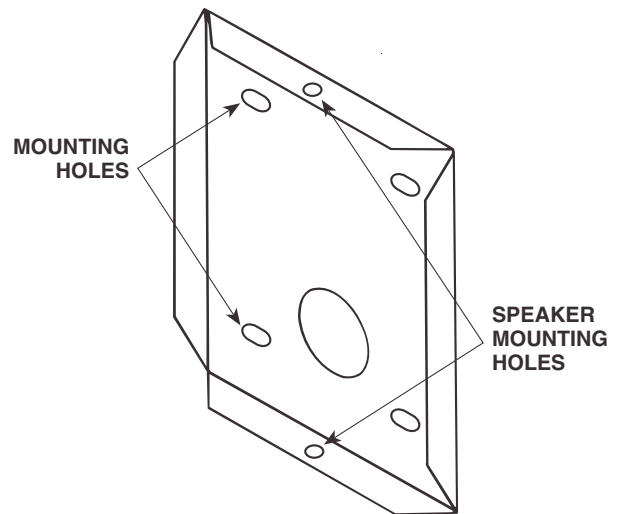
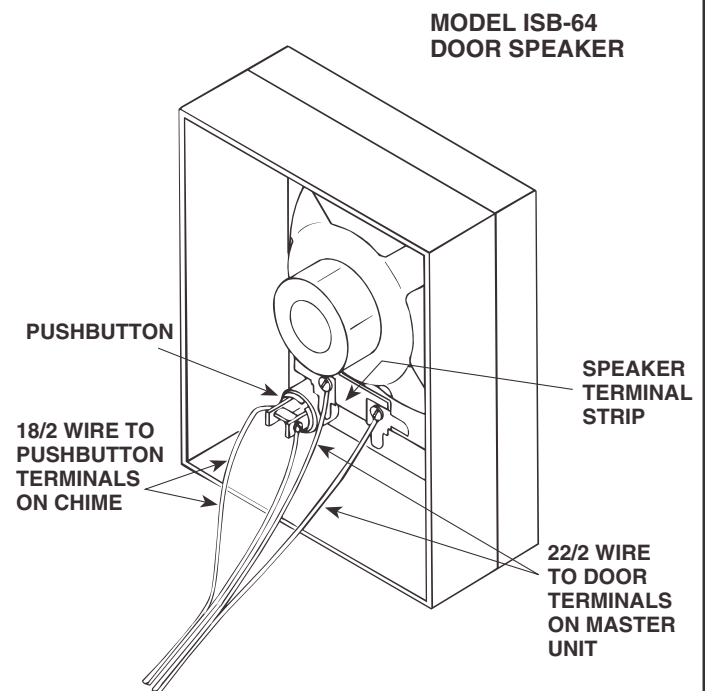
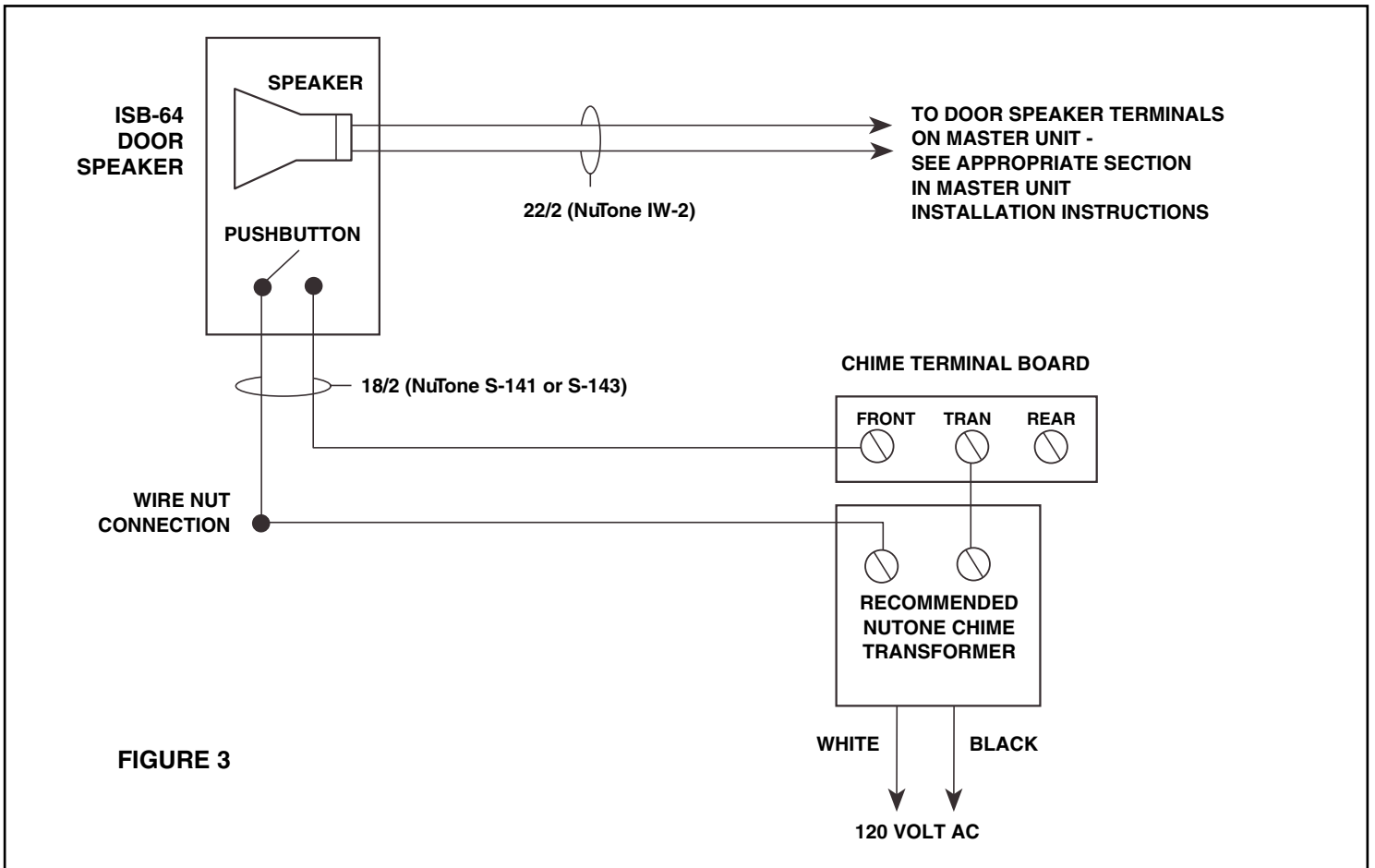

FIGURE 2



(Please see other side for Wiring Diagram.)



NuTone®

Two Year Limited Warranty

WARRANTY OWNER: NuTone warrants to the original consumer purchaser of its products that such products will be free from defects in materials or workmanship for a period of two (2) years from the date of original purchase. **THERE ARE NO OTHER WARRANTIES, EXPRESS OR IMPLIED, INCLUDING, BUT NOT LIMITED TO, IMPLIED WARRANTIES OF MERCHANTABILITY OR FITNESS FOR A PARTICULAR PURPOSE.**

During this two year period, NuTone will, at its option, repair or replace, without charge, any product or part which is found to be defective under normal use and service. THIS WARRANTY DOES NOT EXTEND TO FLUORESCENT LAMP STARTERS OR TUBES, FILTERS, DUCT, ROOF CAPS, WALL CAPS AND OTHER ACCESSORIES FOR DUCTING. This warranty does not cover (a) normal maintenance and service or (b) any products or parts which have been subject to misuse, negligence, accident, improper maintenance or repair (other than by NuTone), faulty installation or installation contrary to recommended installation instructions.

The duration of any implied warranty is limited to the one year period as specified for the express warranty. Some states do not allow limitation on how long an implied warranty lasts, so the above limitation may not apply to you.

NUTONE'S OBLIGATION TO REPAIR OR REPLACE, AT NUTONE'S OPTION, SHALL BE THE PURCHASER'S SOLE AND EXCLUSIVE REMEDY UNDER THIS WARRANTY. NUTONE SHALL NOT BE LIABLE FOR INCIDENTAL, CONSEQUENTIAL OR SPECIAL DAMAGES ARISING OUT OF OR IN CONNECTION WITH PRODUCT USE OR PERFORMANCE. Some states do not allow the exclusion or limitation of incidental or consequential damages, so the above limitation or exclusion may not apply to you. This warranty gives you specific legal rights, and you may also have other rights, which vary from state to state. This warranty supersedes all prior warranties.

WARRANTY SERVICE: To qualify for warranty service, you must (a) notify NuTone at the address stated below or telephone 1/800-543-8687, (b) give the model number and part identification and (c) describe the nature of any defect in the product or part. At the time of requesting warranty service, you must present evidence of the original purchase date.

Date of Installation _____ Builder or Installer _____

Model No. and Product Description _____

IF YOU NEED ASSISTANCE OR SERVICE:
 For the location of your nearest NuTone Independent Authorized Service Center:
Residents of the contiguous United States Dial Free 1-800-543-8687
 Please be prepared to provide:
 Product model number • Date and Proof of purchase • The nature of the difficulty

Residents of Alaska or Hawaii should write to: NuTone Inc. Attn: Department of National Field Service, 4820 Red Bank Road, Cincinnati Ohio 45227-1599.
Residents of Canada should write to: Broan-NuTone Canada, 1140 Tristar Drive, Mississauga, Ontario, Canada L5T 1H9.

Rev. 03/2001