

RADIO-INTERCOM SYSTEM

MODEL: IMA-3303 Series Master Station

This booklet contains information for installing the Master Station. All system wiring and rough-in frames should be installed **before** mounting and wiring the master station.

Refer to the installation instructions packaged with the rough-in frame for detailed wiring information. For more

detailed information on wiring and mounting other system components (i.e. speakers, remote controls, etc.), refer to the installation instructions packaged with each separate component.

IMA-3303 SERIES REPRESENTATIVE WIRING ILLUSTRATION

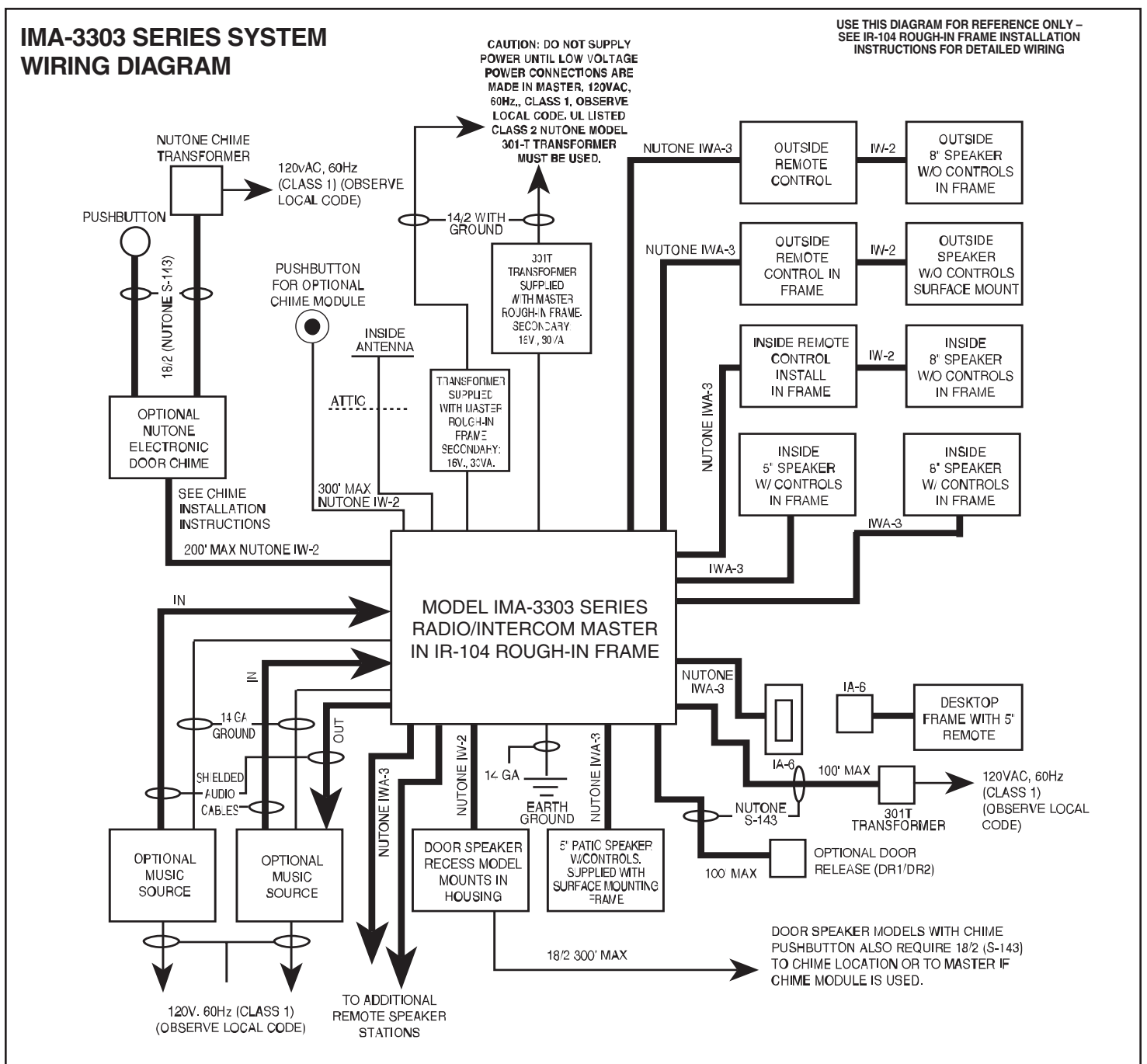

INSTALLATION

Wiring Specifications

NuTone IW-2: 22 GA. Twisted Pair.

NuTone IWA-3: Flat Ribbon Type 3-wire, 22 GA. cable.

NuTone S-143: 18 GA. 2-conductor insulated.

No. 14/2: 120v, 60Hz Power Cable: Class 1. U.L. Listed
(not supplied by NuTone).

14 GA.: Ground Wire (not supplied by NuTone).

Speaker Wiring

An individual 3-wire cable (IWA-3) must be connected from each remote speaker or remote control to the master unit's terminal board.

- **Maximum speaker run:** 300 feet.
- **Maximum total of IWA-3 per system:** 2000 feet.

IMPORTANT: NuTone cannot be responsible for improper radio-intercom operation that results from interference generated by light dimmers, fluorescent lighting fixtures, and similar electrical products. Such interference must be corrected at the source. TO HELP REDUCE THIS INTERFERENCE, ALL REMOTE SPEAKER WIRES AND CABLES MUST BE PLACED AT LEAST 12 INCHES FROM ANY A.C. POWER WIRING.

Maximum Number of Speakers

Refer to Figure 1. The System will accommodate up to 13 speakers and up to 3 door speakers. If more than 9 Remote Stations are connected, use only terminals 1, 2, 6 and 7 for double wiring connections.

Mounting the Terminal Board

1. Refer to Figure 2. Locate the terminal board in the left rear section of the rough-in frame.
2. Use four No. 6 x $\frac{3}{8}$ " screws (supplied) to secure the terminal board to rough-in frame.
3. Make certain that the lower right screw is secure and snug against the ground lug which covers mounting hole in terminal board. Do not bend ground lug. Make sure it is positioned between mounting screw and terminal board.

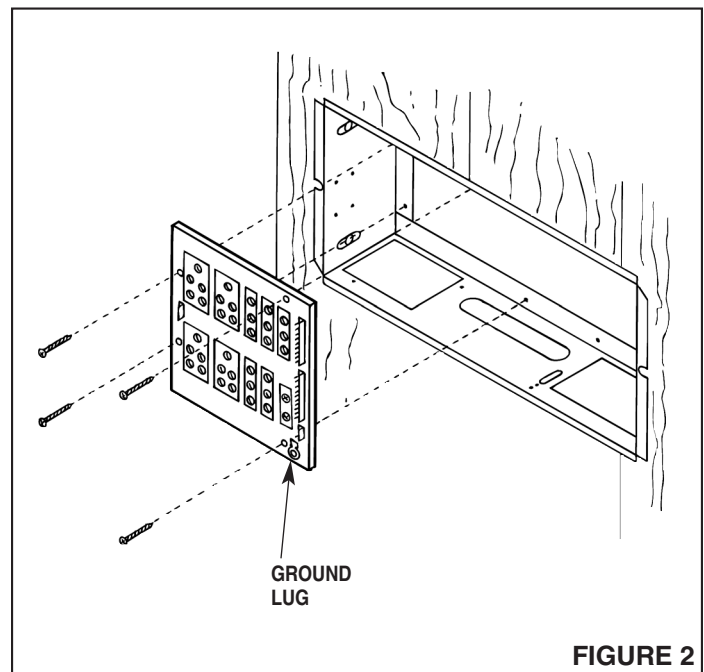
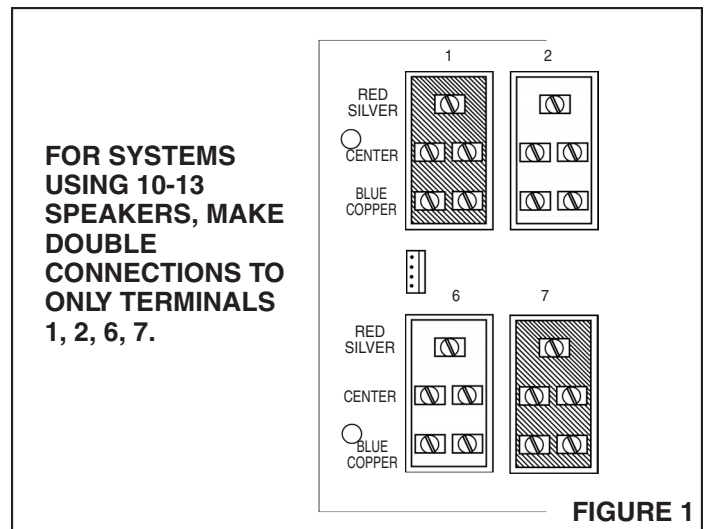

IMPORTANT:
DO NOT APPLY POWER TO THE SYSTEM
UNTIL ALL CONNECTIONS ARE COMPLETE.

INSTALLATION (Continued)

Wire Matching Chart

NuTone has adopted the use of a 3-wire color-coded cable. If you are replacing an older model radio-intercom, use this chart to match the copper/center/silver designations of older wiring with the blue/grey/red-stripe color-coded wire.

OLD CABLE	NEW CABLE
Wire	Insulation
Copper	Blue
Center	Grey
Silver	Red Stripe

Connecting the Remote Speaker Wiring

NOTE: All speaker and door wiring must return directly to Master unit. Do not connect wiring from speaker to speaker.

1. Dress all speaker wiring through the oblong wire holes in the rough-in frame. All wiring connections are made to the Master unit's terminal board.
2. Refer to Figure 6. When routing speaker wires through rough-in, run wires through the **LEFT-HAND** side of the upper and/or lower wiring channels.
3. Refer to Figures 3, 4 & 5. Connect the three-conductor wire (IWA-3) from each speaker to a set of terminal screws. Connect speaker wiring as follows:
RED STRIPE wire to terminal screw marked **RED SILVER**.
GREY wire to terminal screw marked **CENTER**. **BLUE** wire to terminal screw marked **BLUE COPPER**.
4. Refer to Figure 5. The system will accommodate up to 13 speakers. If more than 9 speakers are connected, use only terminals 1, 2, 6 and 7 for double wiring connections.

When connecting two remotes to screw terminals 1, 2, 6 and 7.

- Connect both red wires to the **RED SILVER** terminal screw.
- Connect one remote's **GREY** wire to a **CENTER** terminal screw, and connect the second remote's center wire to the second **CENTER** terminal screw.
- Connect one remote's **BLUE** wire to a **BLUE COPPER** terminal screw, and connect the second remote's **BLUE** wire to the second **BLUE COPPER** terminal screw.

Repeat this procedure for each double remote connections. **NOTE:** Failure to make these double connections properly will cause the unit to squeal.

5. Refer to installation instructions packaged with remote speakers or remote controls for wiring of the units.
6. See "Wire Matching Chart" if you are retrofitting a system with the previously used Copper/ Center/ Silver wire.

Connecting the Door Speaker Wiring

1. The door speaker connects to the Master terminal board with two conductor (IW-2) 22 gauge twisted pair wire.
2. Refer to Figure 4. Connect the two wires from the door speaker(s) to the two terminal screws marked **DOOR SPKR** on the Master Terminal board.

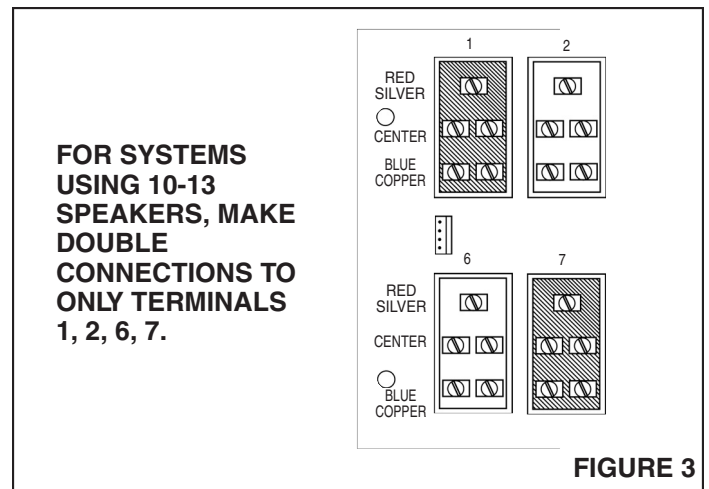

FIGURE 3

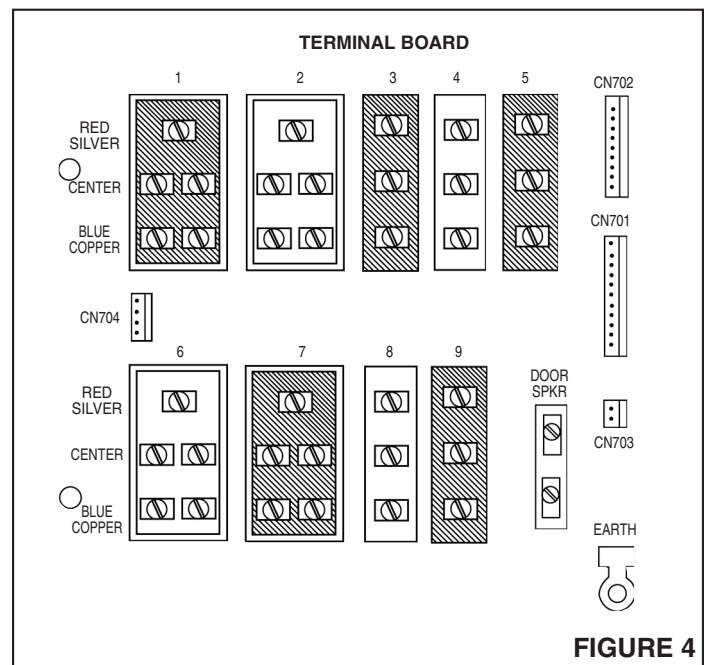

FIGURE 4

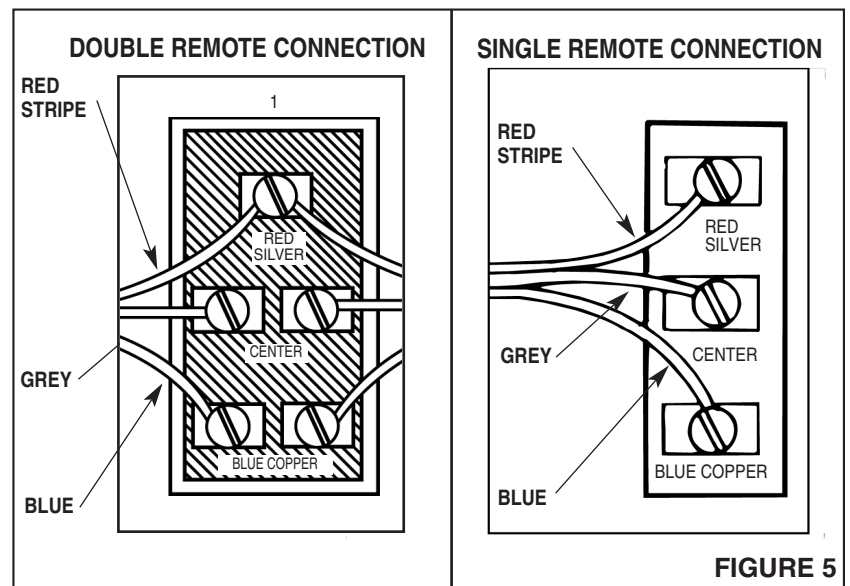
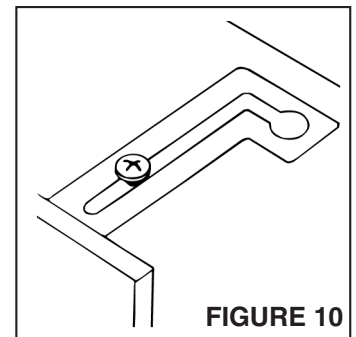
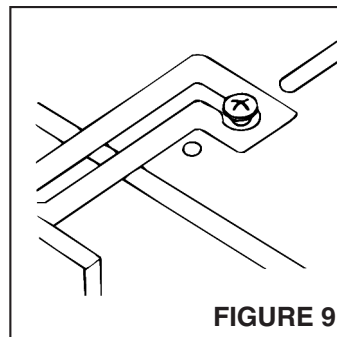
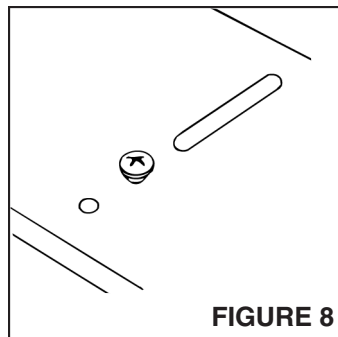
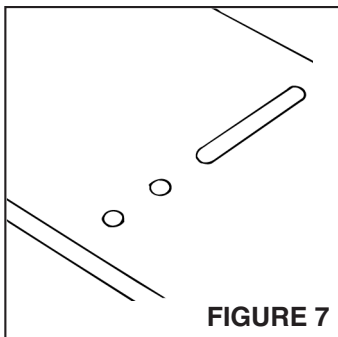
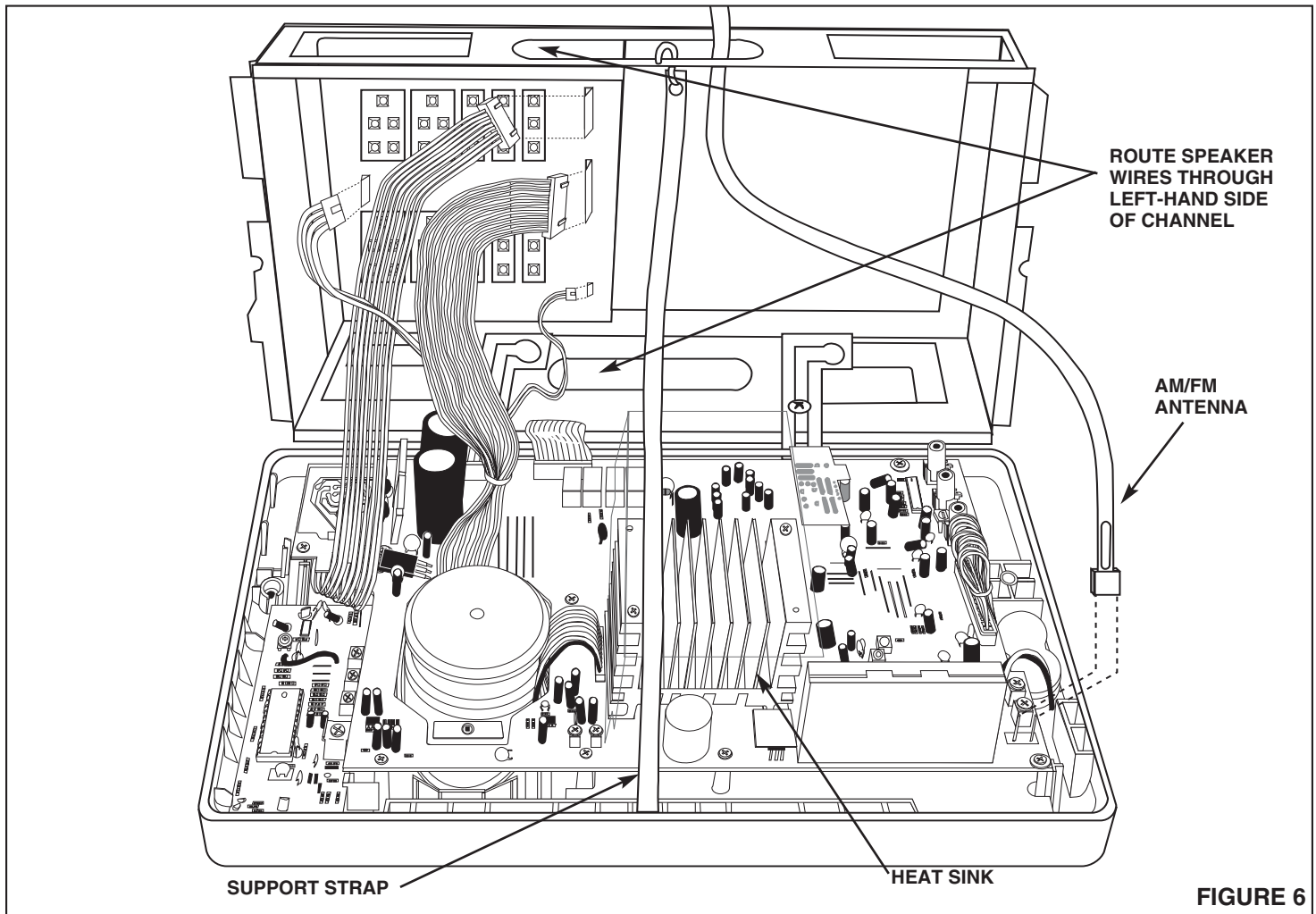

FIGURE 5

INSTALLATION (Continued)

Mounting the Master Panel

1. Refer to Figure 6. Use two (2) no. 6 x $\frac{3}{8}$ " screws to attach mounting brackets to rough-in frame. **Using bottom set holes, make sure brackets are flush to wall or rough-in and screws are tight.**
2. Refer to Figures 7 and 8. For rough-in frames which are recessed into the wall opening, insert two (2) shoulder screws (provided) into the front two holes in the rough-in frame. **For rough-in frames which are mounted flush with the wall, insert two (2) shoulder screws (provided) into the back two holes in the rough-in frame.**
3. Refer to Figure 9. Attach master panel to rough-in frame by placing keyhole slots in both mounting hinges over screw heads in rough-in frame.
4. Refer to Figure 10. Slide master panel to the right, then forward until panel is flush with the wall.
5. Align master panel with rough-in frame.
6. Refer to Figure 6. Attach support strap to rough-in by attaching onto oblong hole in top of rough-in frame.



INSTALLATION (Continued)

Connecting Antenna

1. Connect the AM/FM antenna (supplied with the IR-104 rough-in) to the 2-pin connector located in the upper right corner of the main PC board.

In most locations, the antenna supplied with the rough-in provides adequate AM reception. However, in rural or weak signal areas a separate AM antenna may be required. Use the following instructions for selecting and connecting a separate AM antenna.

1. Refer to Figure 11. Move the the auxiliary AM antenna selector switch to the AM position.
2. Connect 50 feet of 22 GA. insulated wire (not supplied by NuTone) to the screw terminal marked AUX AM ANTENNA.
3. Run the wire from the Master location to the attic. Fasten the insulated wire at one end of the attic, stretch the wire to its full length, and fasten at the opposite end. Fasten the insulated wire at several locations between ends to prevent sagging.

Selecting Remote Radio Control Features

CONTROLLING THE RADIO FROM REMOTE STATIONS

The radio may be turned on/off or a stored radio memory channel may be selected at any remote station as follows:

RADIO ON/OFF

Press and hold the **END CALL** key for 2 seconds. The radio will turn on or off depending on the present state of the radio.

RADIO MEMORY CHANNEL SELECTION

Momentarily press the **END CALL** key. The radio will sequentially step through the stored radio memory channels.

If desired, these functions may be disabled as follows:

DISABLING REMOTE STATION RADIO ON/OFF

Refer to Figure 12. Slide the switch labeled **POWER** located on the master station's main PC board to the **OFF** position. This will disable the remote station radio on/off function at **ALL** remote stations.

DISABLING REMOTE STATION RADIO MEMORY CHANNEL SELECTION

Refer to Figure 12. Slide the switch labeled **TUNING** located on the master station's main PC board to the **OFF** position. This will disable the remote station radio memory channel selection function at **ALL** remote stations.

Installing and Connecting Optional Door Release Push Button

Refer to Figure 13.

1. Open right-hand panel door.
 2. Cut 4 retainer webs from pushbutton hole cover.
 3. Remove cover.
 4. Feed one wire from Door Release Transformer and one wire of Door Release mechanism through push button hole.
- NOTE:** The door release requires a separate 301T Transformer.
5. Connect the 2 wires to the pushbutton.
 6. Rotate the pushbutton so the screws are on the top and bottom as illustrated, then snap the button into the mounting hole.

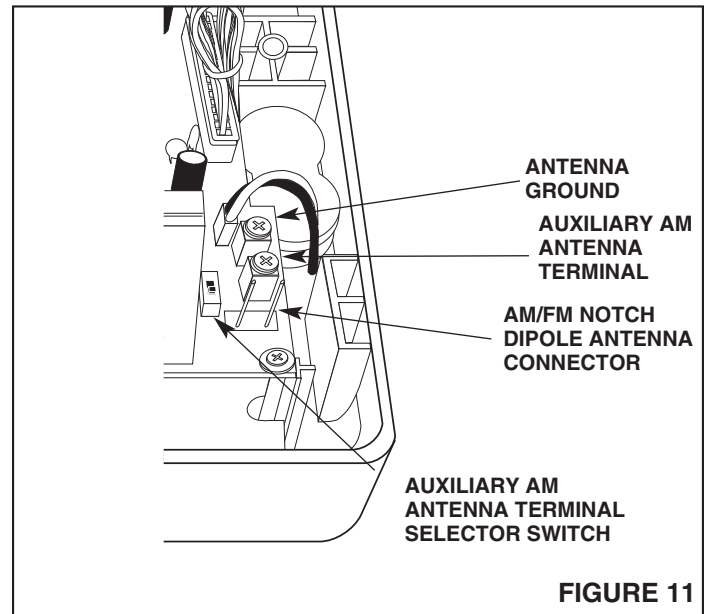

FIGURE 11

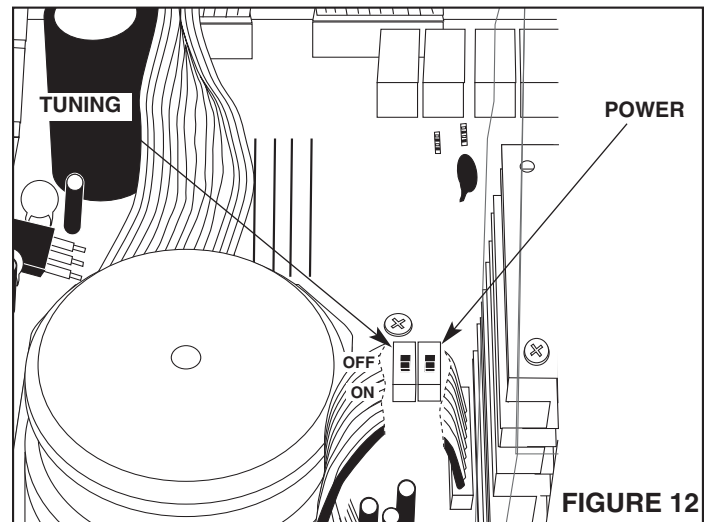

FIGURE 12

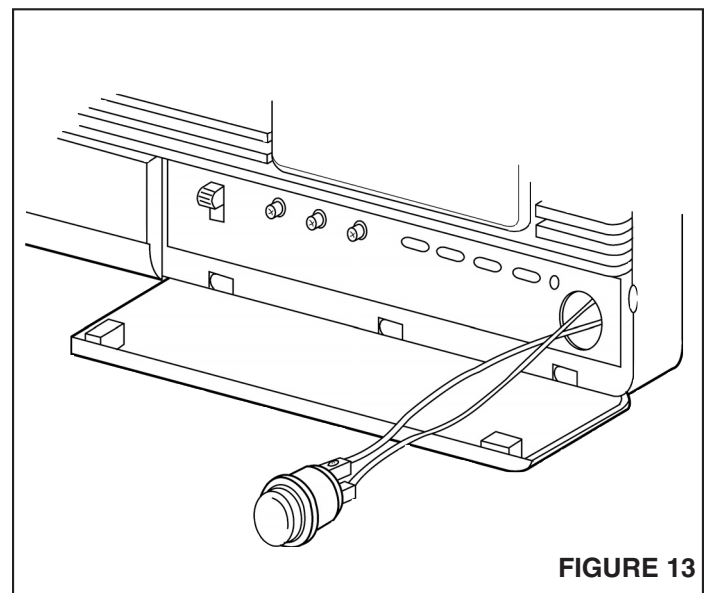

FIGURE 13

INSTALLATION (Continued)

Connecting the Master Panel to the Terminal Board

Refer to Figure 14. Connect the 11, 9, 4 & 2 pin plugs from the Master to the appropriate connectors on the terminal boards.

Connecting Optional Accessories

1. Refer to Figure 15. To connect an external audio source (CD, Cassette, etc.) to the IMA-3303 Radio Intercom, locate the CD/TAPE and AUXiliary input on the lower right side of the master station's main PC board.
2. Insert the audio source output plug into the appropriate input jack on the master station.
NOTE: The CD/TAPE input has an input level control to allow matching of the external audio source to the built-in AM/FM tuner.
3. To use the selected source audio for recording onto a cassette recorder, insert the tape recorder's input plug into the master station's LINE OUT jack.
4. **OPTIONAL HOOK-UP TO PROVIDE RADIO ONLY:**
The radio and optional entertainment sources can be channeled through an auxiliary amplifier (purchase NuTone Model: IMA-516 separately) to provide uninterrupted music (no intercom) to separate speakers. This type of installation can be used for a doctor's office, where intercom and music are desired in the office area, but music only in the waiting room.
NOTE: If an auxiliary amplifier is used, connect the master station's line out jack to the auxiliary amplifier's low-level radio input wires.

Connecting the Optional Electronic Chime

Refer to Figure 16.

1. Connect NuTone IW-2 cable from the chime to the (+) and (-) screw terminals.
 2. Refer to the Installation Instructions packaged with the chime for complete wiring information.
- IMPORTANT: FAILURE TO USE NUTONE IW-2 CABLE WILL CAUSE THE SYSTEM TO HUM AT ALL TIMES.**

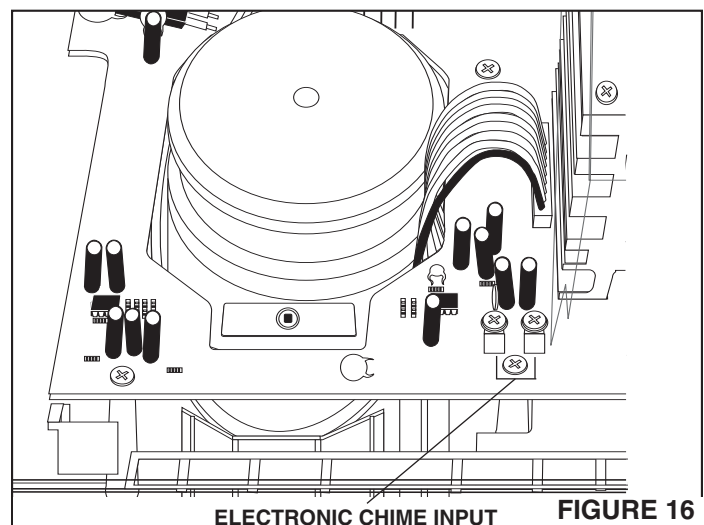
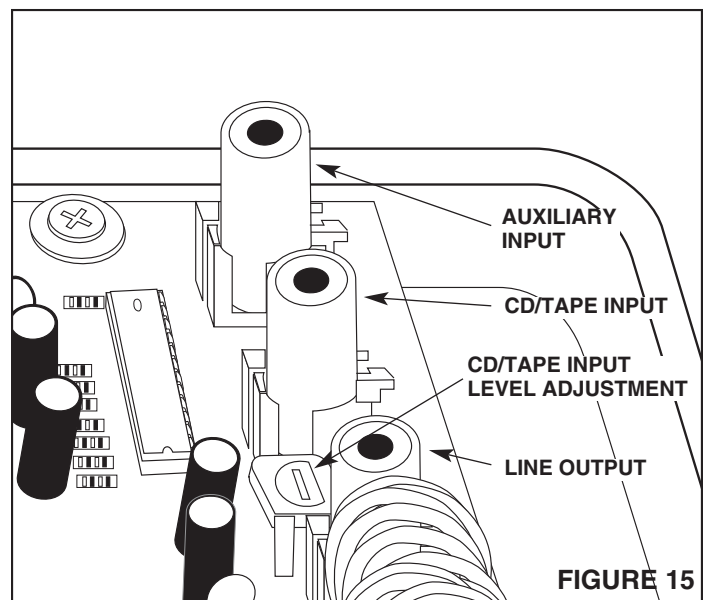
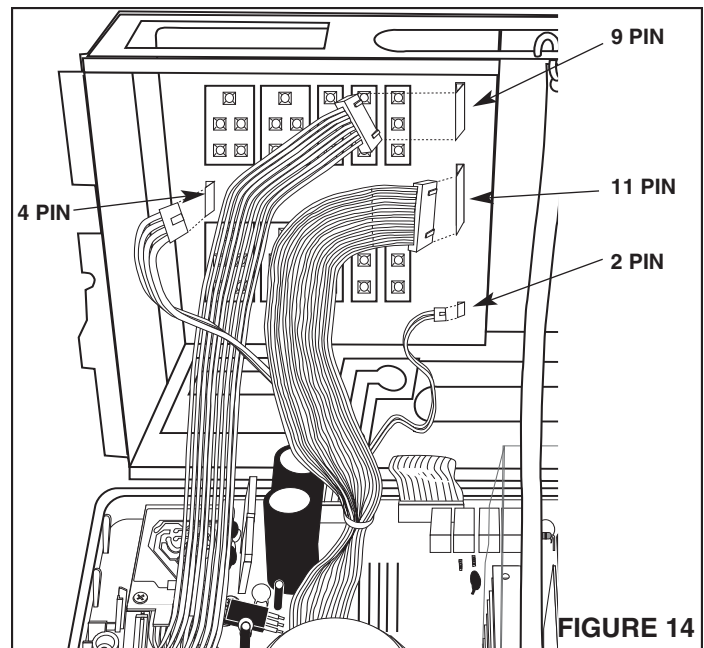

INSTALLATION (Continued)

Connecting the Optional Electronic Chime Module

MODELS IA-28 OR IA-29

1. Connect wires from door pushbuttons - front, rear and side - to chime module.
2. Refer to the instructions packaged with the chime module for complete wiring information.
3. **Refer to Figure 17.** Locate the chime module mounting bracket.
4. Align the chime module with the mounting bracket. Apply firm, even pressure to each side of the chime module. The chime module will snap into place. Fasten module to panel with one screw (supplied with chime module).
5. Plug 4 pin plug from chime module into connector on Master board.

MODEL IA-29 ONLY

5. Locate the chime selector switch mounting bracket.
6. Remove the chime selector switch retaining screws.
7. Position the chime selector switch onto the posts and reinstall the retaining screws.
8. Route the selector switch wires as illustrated to prevent the wires from interfering with the front panel mounting bracket.

Connecting the Transformers

NOTE: Be sure all intercom wiring has been properly terminated to the terminal board and remote stations **before** applying power to the system.

1. **Refer to Figure 18.** The transformers' primary leads should already be connected to the 120vAC house supply wiring. Be sure power is off to transformer before connecting Master.
2. Two sets of low voltage supply leads are located in the bottom left corner of the master station. Connect one pair of supply leads to each transformer located in the bottom of the rough-in.

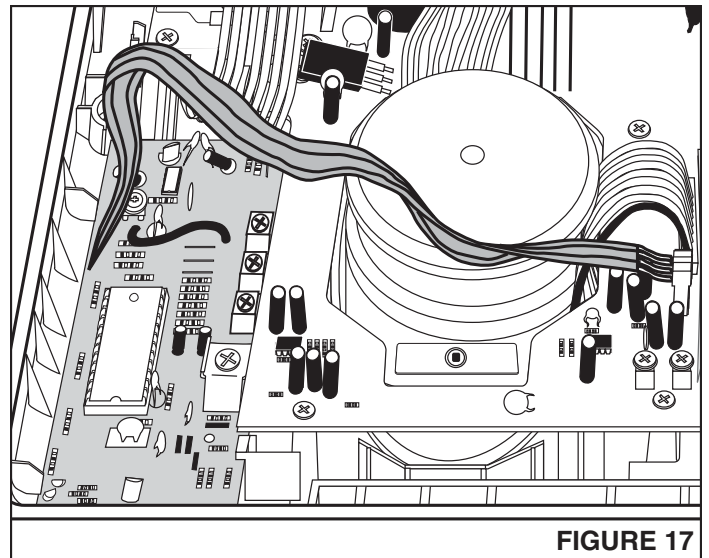

FIGURE 17

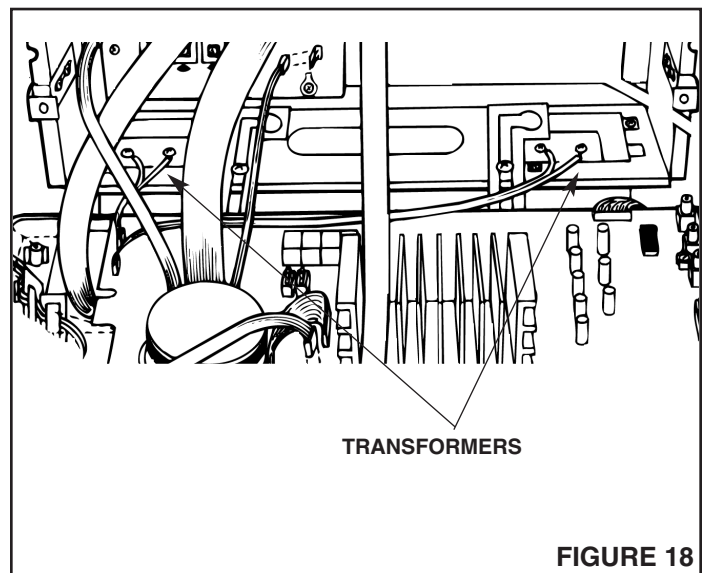

FIGURE 18

INSTALLATION (Continued)

Securing the Master Panel

1. Refer to Figure 20. Inspect all wiring connections to make sure they are complete and correct.
2. Make sure all antenna connections are secure.
3. Position all Remote Speaker wires toward the **LEFT-HAND** side of the wiring channel to prevent interference with the unit's heat sink.
4. Position Master panel over rough-in frame, and align screw holes in Master panel with mounting brackets.
5. Secure Master panel to rough-in mounting brackets with two screws (supplied).

NOTE: The screws will pierce the wall surface behind the mounting brackets. If wall surface is hard, a clearance hole must be drilled behind mounting brackets before securing Master panel.

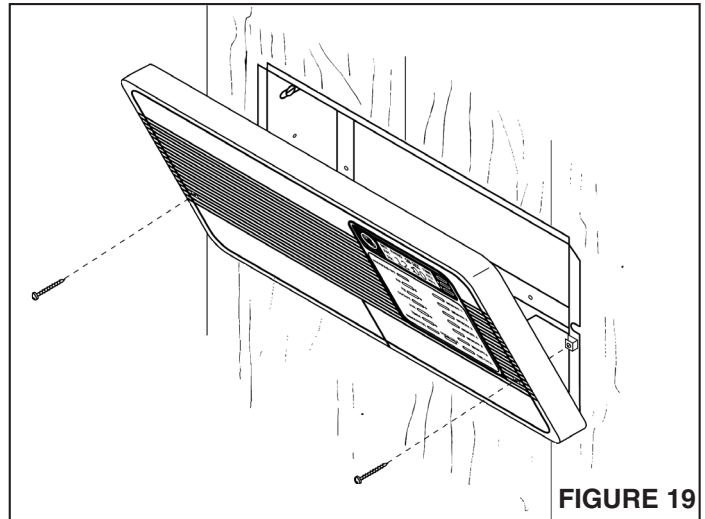

FIGURE 19

SYSTEM OPERATING CONTROLS

Master Station Controls

- ① **END CALL:** Ends intercom communication and returns system to audio source.
- ② **DOOR TALK:** Initiates intercom communication to the door speakers.
- ③ **INSIDE/PATIO:** Initiates intercom communication to remote stations.
- ④ **TIMER:** Enables or disables the radio timer. The indicator light will illuminate next to the timer button when the Radio timer is enabled.
- ⑤ **PROGRAM AUDIO SOURCE:** Selects the program audio source: AM, FM, CD/TAPE and AUX. The indicator light will illuminate next to the selected program audio source.
- ⑥ **PROGRAM OFF:** Turns off the selected program audio source. **NOTE:** The Program Off key does not affect the intercom operation.
- ⑦ **MASTER VOLUME:** Adjusts the volume at the master station.
- ⑧ **MEMORY 1-6 KEYS:** Provides direct access to stored radio frequencies.
- ⑨ **▲ ▼ UP/DOWN TUNING:** Provides manual tuning of the AM/FM radio.
- ⑩ **SCAN:** Activates scan tuning during AM/FM operation.
- ⑪ **DOOR RELEASE KNOCKOUT:** Mounting hole for optional door release push button.
- ⑫ **MICROPROCESSOR RESET:** Initiates a reset of the microprocessor. **NOTE:** A reset of the microprocessor will erase the system's memory.
- ⑬ **MEMORY SET:** Stores desired radio frequency into a selected memory location.
- ⑭ **TIME SET/HOUR/MIN:** Used when setting the timer and clock.
- ⑮ **TREBLE:** Adjusts the high frequency audio content of the source audio.
- ⑯ **BASS:** Adjusts the low frequency audio content of the source audio.
- ⑰ **SYSTEM VOLUME:** Adjusts the program audio level throughout the system.
- ⑱ **LOUDNESS:** Compensates for the loss of bass and treble response the human ear has when listening to audio at low volume levels.
- ⑲ **INTERCOM VOLUME:** Adjusts intercom audio level throughout the system.
- ⑳ **MASTER STATION STATUS SWITCH:** Sets the master station in one of the following modes: RADIO INTERCOM, INTERCOM ONLY, OFF or MONITOR.
- ㉑ **REMOTE STATION STATUS SWITCHES:** Sets the remote stations in one of the following modes: RADIO INTERCOM, INTERCOM ONLY, OFF or MONITOR.
- ㉒ **ELECTRONIC CHIME TUNE SELECTION:** Selects the tune of the optional IA-29 Electronic chime.

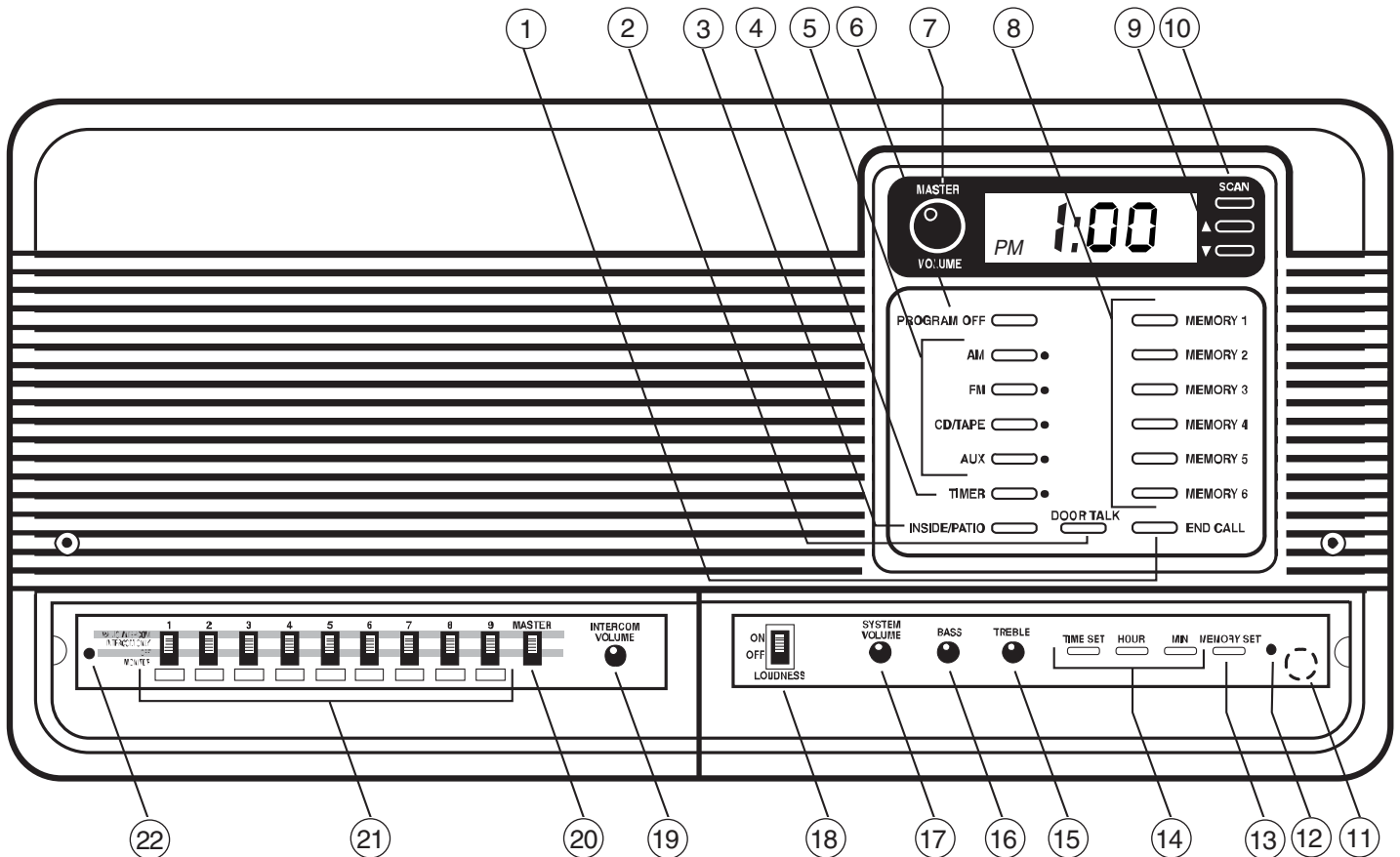

FIGURE 20

SYSTEM OPERATING CONTROLS

Digital Clock

SETTING THE TIME

1. Press the **TIME SET** key one time. The display will begin flashing, and the words **SET TIME** will be displayed.
2. Within 5 seconds, press the **HOUR** key to advance the hours. Use the **HOUR** key to select AM/PM by advancing past 12:00 on the display.
3. Within 5 seconds, press the **MIN** key to advance the minutes.
4. After entering the correct time, release the key. The display will stop flashing after 5 seconds, and the time will be set.

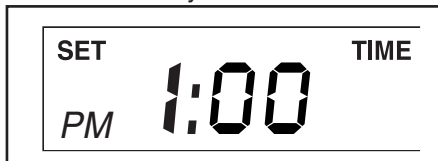

Operational Checkout

If the Radio-Intercom does not operate according to the following instructions, refer to the Installer's Troubleshooting Guide.

1. Set STATION STATUS SWITCHES to the **RADIO/INTERCOM** position.
2. Set the **MASTER VOLUME** control to maximum.
3. Set each individual station **VOLUME** control to maximum.
4. Set the **SYSTEM VOLUME** control to $\frac{1}{2}$ position.
5. Set the **INTERCOM VOLUME** to $\frac{3}{4}$ position.
6. Set the **BASS** and **TREBLE** controls to the $\frac{1}{2}$ position.
7. Tune in a strong FM radio station as follows:
 - A. Press the FM key
 - B. Use the **▲ ▼** keys to locate a strong FM radio station.

Beginning with the master station, check each station in the system for proper operation using the following procedure:

1. Adjust the station's Volume Control (Master Volume on the master station) between maximum and minimum, making sure the audio is completely muted in the minimum position and no noise is created by the volume control during adjustment.
2. Press the **INSIDE/PATIO** key. Radio audio will mute and audio from the station will be heard at all stations in the system, except the door speaker(s).
3. Release the **INSIDE/PATIO** key to hear the reply.
NOTE: To reply to an intercom call initiated at a remote station, the Inside/Patio key must be pressed at the station responding to the intercom call. If, however, an intercom call is initiated at the master station, the Inside/Patio key does not need to be pressed at the station responding to the intercom call. Audio from the responding stations and all stations in the system will be heard at the master station when the **INSIDE/PATIO** key is released.
4. Press the **END CALL** key. Intercom communication will end, and radio audio will return to all stations in the system.
5. Press the **DOOR TALK** key. Radio audio will mute, and audio from the station will be heard at the door speaker(s) and all stations in the system.

6. Release the **DOOR TALK** key. Audio from the door speakers will be heard at all stations in the system.
7. Press and hold the **END CALL** key. Door communication will end, and radio audio will return to all stations in the system.
8. Press and hold the **END CALL** key for 2 seconds. The radio will turn off.
9. Press and hold the **END CALL** key for 2 seconds. The radio will turn on. See page 5 for information on controlling the radio from a remote station.
10. Repeat procedure at next station.

Setting System Volume

The volume levels required at each Station may vary with the locations of the speaker and the size of the room where the speaker is located. Spend some time experimenting with volume levels, and adjust each speaker so that you can clearly hear the radio and intercom. Use the following procedures to set your system's volume levels:

1. At each remote station, turn the volume control completely clockwise to maximum volume.
2. At the master station, set the REMOTE and MASTER SPEAKER STATUS switches to the **RADIO INTERCOM** position.
3. Turn the **MASTER VOLUME** control to maximum volume.
4. Turn the **SYSTEM VOLUME** control on the master station to approximately one-third volume.
5. Select an AM or FM radio station with a strong, clear signal.
6. Adjust the master station's **SYSTEM VOLUME** control until you have enough volume at the remote station that requires the highest volume (i.e. a large living room, family room, basement, etc.).
NOTE: The Master Station and all Remote Stations (except the door speakers) are equipped with their own volume controls. Although the Master Station SYSTEM VOLUME sets the System's Volume level, you may adjust an individual speaker's volume level as desired.
7. Adjust the **MASTER VOLUME** control and all remote stations' **VOLUME** controls to the volume level you desire. Do not set the remote stations' volume controls below $\frac{1}{2}$ volume.

Setting Intercom Volume

1. Initiate Intercom call from the master station by pressing the **INSIDE PATIO** key.
2. Speak with a normal voice about 2-3 feet from the station speaker.
3. Adjust the **INTERCOM VOLUME** control until the initiating station's audio is clearly heard at all stations in the system.
NOTE: The volume control at all stations should be set between $\frac{1}{2}$ to maximum volume for proper intercom operation.
4. Repeat the above procedure at several locations until an acceptable intercom audio level is achieved at all stations.

OPERATIONAL CHECKOUT

Diagnostic Tests

The following diagnostic test have been incorporated into the NuTone IMA-3303 Radio Intercom to assist in system troubleshooting.

1. Master station keyboard test
2. Control line voltage test
3. Display test

The following applies to all three diagnostic tests:

1. To access any of the diagnostic tests, the system must be in the quiescent state (radio off and intercom in the standby mode).
2. Pressing the MEMORY SET key will end the current diagnostic test.
3. The current diagnostic test will end after one minute of inactivity.

NOTE: An incorrect control line voltage caused by miswiring or a defective remote station may prevent the unit from entering the diagnostic mode. This condition, however, can be circumvented by first placing all station selector switches into the OFF mode and then disconnecting CN701 from the terminal board. The voltage on the control line can then be measured by activating the control line voltage test mode and then reconnecting CN701.

1. **MASTER STATION'S KEYBOARD TEST** – Verifies that all keys on the master station are functioning properly.

To Activate: Press and HOLD

1. ▲ key
2. ▼ key
3. MEMORY 1 key.

In this mode the hours in the display represent the current diagnostic test and the minutes indicate the current key being pressed. The following will be displayed as each key is pressed.

KEY	DISPLAY
No key pressed	1:00
SCAN	1:01
▲	1:02
▼	1:03
PROGRAM OFF	1:04
AM	1:05
FM	1:06
CD/TAPE	1:07
AUX	1:08
TIMER	1:09
INSIDE/PATIO	1:10
DOOR TALK	1:11
END CALL	1:12
MEMORY 1	1:13
MEMORY 2	1:14
MEMORY3	1:15
MEMORY 4	1:16
MEMORY 5	1:17
MEMORY 6	1:18
TIME SET	1:19
HOUR	1:20
MIN	1:21
MEMORY SET	1:22

2. **CONTROL LINE VOLTAGE TEST** – Displays the voltage on the control line.

To activate: Press and HOLD

1. ▲ key
2. ▼ key
3. MEMORY 2 key.

Example:

DISPLAY	VOLTAGE ON CONTROL LINE
2:34	3.4 volts
2:17	1.7 volts
2:06	.6 volts

In this mode, the hours represent the diagnostic test, and the minutes indicate the voltage on the control line.

MODE	VOLTAGE WINDOW	
	MAX	MIN
End Call	4.5V	2.4V
Door Talk	2.4V	1V
Inside/Patio	1.0V	0

The control line voltage windows for the three intercom modes are listed above. For proper intercom operation, the control voltage produced when an intercom key is pressed at a remote station should fall between the voltages indicated.

NOTE: Pressing **END CALL**, **DOOR TALK** or **INSIDE/PATIO** keys at the master station will not change the voltage on the control line.

If a remote station does not produce a voltage within the above windows for a specific intercom function, check the following:

- Make sure all connectors from the master station are properly installed into the terminal PC board.
- Check IWA-3 connections at the terminal PC board and at each remote station.
- Confirm that the suspect remote speaker station functions properly by replacing it with a known good Remote Station.

3. **DISPLAY TEST** – Displays all of the segments in the display.

To Activate: Press and HOLD

1. ▲ key
2. ▼ key
3. MEMORY 3 key

Pressing the ▲ key toggles the display on and off.

INSTALLER'S TROUBLESHOOTING GUIDE

TROUBLE	POSSIBLE CAUSE	POSSIBLE REMEDY
No radio, no intercom. (No Display).	No electrical power.	Be certain 120VAC, 60Hz power has been provided to the primaries of both 301T Transformers. No less than 16VAC should be measured on the secondary of either Transformer.
	Defective transformer.	Replace transformer.
No radio, intercom working. (AM/FM indicator on.)	Faulty Master Station.	Isolate Master Station from installation by removing ribbon cables from terminal board and wait one minute for timeout. With power on, radio should be playing at Master. If no radio, Master is probably faulty. If radio plays, reconnect ribbon cables.
	Installation problem.	Check terminal board for shorted terminals or miswired cables. Remove one 3-wire cable at a time to locate faulty line. When radio comes on, check speaker connections and run continuity check of speaker wiring.
	Antenna problem.	Check for shorted antenna connection. Remove antenna connector from tuner board and touch each pin with metallic object. If radio plays, antenna is not functioning; be sure it is installed properly. In weak signal areas, an outside antenna may be necessary. Also see Connecting Auxiliary AM Antenna
Low or distorted radio volume.	Incorrect volume setting.	Follow "Setting Volume" instructions under OPERATIONAL CHECKOUT.
Low or no intercom volume from remote speaker in MONITOR mode.	Improper operation.	Be sure remote speaker set for MONITOR has its volume control set between ½ and max, and receiving speakers have volume controls set between ½ and max. Follow "SETTING VOLUME" instructions in Operation Checkout.
	Program and Intercom Volume Control adjustment.	Follow these instructions whenever the radio tends to overpower transmissions from a remote speaker in the MONITOR mode. These instructions will help you get the proper balance between the radio and the monitored speaker. 1. Set system volume control to midpoint. 2. Set master to CD/TAPE or AUX position. 3. Adjust volume control for each remote station and speaker in master station ¾ position. 4. Set master to AM or FM and tune to a strong AM or FM station. 5. Adjust program volume control for a desired listening level. 6. Increase Intercom volume control setting. Adjust clockwise to desired monitor volume.
System squeals when using intercom.	Shorted wire on master or remote terminal board.	Check for short between terminals or loose wire.
	Two or more Remote Stations on same wire run to Master.	Make separate cable (IWA-3) runs from each Remote Station to the Master.
	Speakers in adjacent rooms mounted on common wall, or mounted back to back.	If speakers are mounted directly back to back, one speaker will have to be relocated. If speakers are in a common wall, try placing fiberglass insulation behind each speaker, or isolate the speakers from the wall by placing rubber washers or weather stripping between speaker and wall.
	Improper wire used in installation.	NuTone Model IWA-3-conductor, flat-ribbon cable must be used.
	Improper double connections of Remote Stations on terminal screws 1, 2, 6 & 7.	Follow "Connecting the Remote Speaker Wiring" under INSTALLATION.

INSTALLER'S TROUBLESHOOTING GUIDE

TROUBLE	POSSIBLE CAUSE	POSSIBLE REMEDY
Hum in speakers.	Intercom wiring run too close to household AC power wiring.	Keep intercom wiring as far as practical from household AC power wiring. Do not run intercom wiring parallel to AC power wiring.
	Shorted intercom power wiring or power wiring shorted to ground.	Check power connections to Master and connections to transformers.
	Interference from household electrical fixtures.	A dimmer may cause interference. For dimmer and fluorescent lighting interference, use filters (G.E. 89G635 or equivalent; NuTone Part No.: 1559A-000).
Static.	Loose ground connection.	Check ground connection to Master and connection to earth ground source.
	Interference from household electrical fixtures.	A dimmer may cause interference. For dimmer and fluorescent lighting interference, use filters (G.E. 89G635 or equivalent; NuTone Part No.: 1559A-000).
	Interference from household electrical appliances.	Correct interference at the source: fish tank, heater, hand tool, coffee pot, etc.
Remote Station not working.	Wire installation.	Check terminal board for broken wire or loose connection. Check continuity of wire.
	Speaker.	Check continuity of speaker. Clean switch controls. Substitute with speaker known to be in working order.
No door communication.	Wire installation.	Check continuity of wiring. Check connections at speaker and Master.
	Speaker.	Check with a speaker known to be in working order.
Optional Electronic Chime (Models IA-28 or IA-29) does not operate or operates at a low level.	Wire installation.	Be certain the chime is properly connected to the master station. Also, be certain the front, side and rear buttons are properly connected to the chime board.
	Improper volume setting.	Adjust the volume of the chime module by turning the volume potentiometer located on the chime module. NOTE: Chime Audio will NOT be heard at stations selected to the OFF or MONITOR.
Electronic chime can't be heard through the master station or remote speakers.	Wire installation.	Be certain the electronic chime is properly connected to the master station's electronic chime input screw terminals.
	Improper volume setting.	Adjust the volume of the electronic chime by turning volume potentiometer located on the chime.
Cannot receive radio station which is received by another radio in home.	Faulty antenna connection.	Antenna should be located in attic and connected to tuner in Master. Check antenna connector to be sure it is connected to header on tuner board.

NuTone[®]

Two Year Limited Warranty

WARRANTY OWNER: NuTone warrants to the original consumer purchaser of its products that such products will be free from defects in materials or workmanship for a period of two (2) years from the date of original purchase. **THERE ARE NO OTHER WARRANTIES, EXPRESS OR IMPLIED, INCLUDING, BUT NOT LIMITED TO, IMPLIED WARRANTIES OF MERCHANTABILITY OR FITNESS FOR A PARTICULAR PURPOSE.**

During this two year period, NuTone will, at its option, repair or replace, without charge, any product or part which is found to be defective under normal use and service. THIS WARRANTY DOES NOT EXTEND TO FLUORESCENT LAMP STARTERS OR TUBES, FILTERS, DUCT, ROOF CAPS, WALL CAPS AND OTHER ACCESSORIES FOR DUCTING. This warranty does not cover (a) normal maintenance and service or (b) any products or parts which have been subject to misuse, negligence, accident, improper maintenance or repair (other than by NuTone), faulty installation or installation contrary to recommended installation instructions.

The duration of any implied warranty is limited to the one year period as specified for the express warranty. Some states do not allow limitation on how long an implied warranty lasts, so the above limitation may not apply to you.

NUTONE'S OBLIGATION TO REPAIR OR REPLACE, AT NUTONE'S OPTION, SHALL BE THE PURCHASER'S SOLE AND EXCLUSIVE REMEDY UNDER THIS WARRANTY. NUTONE SHALL NOT BE LIABLE FOR INCIDENTAL, CONSEQUENTIAL OR SPECIAL DAMAGES ARISING OUT OF OR IN CONNECTION WITH PRODUCT USE OR PERFORMANCE. Some states do not allow the exclusion or limitation of incidental or consequential damages, so the above limitation or exclusion may not apply to you. This warranty gives you specific legal rights, and you may also have other rights, which vary from state to state. This warranty supersedes all prior warranties.

WARRANTY SERVICE: To qualify for warranty service, you must (a) notify NuTone at the address stated below or telephone 1/800-543-8687, (b) give the model number and part identification and (c) describe the nature of any defect in the product or part. At the time of requesting warranty service, you must present evidence of the original purchase date.

Date of Installation

Builder or Installer

Model No. and Product Description

IF YOU NEED ASSISTANCE OR SERVICE:

For the location of your nearest NuTone Independent Authorized Service Center:

Residents of the contiguous United States Dial Free 1-800-543-8687

Please be prepared to provide:

Product model number • Date and Proof of purchase • The nature of the difficulty

Residents of Alaska or Hawaii should write to: NuTone Inc. Attn: Department of National Field Service, 4820 Red Bank Road, Cincinnati Ohio 45227-1599.

Residents of Canada should write to: Broan-NuTone Canada, 1140 Tristar Drive, Mississauga, Ontario, Canada L5T 1H9.

Rev. 03/2001

Product specifications subject to change without notice.

4820 Bank Road, Cincinnati, Ohio 45227
Printed in China, 10/03, Part No. 83068