

RADIO-INTERCOM SYSTEM

MODEL: IM-5006 SERIES MASTER STATION

This booklet contains information for installing the master station. All system wiring and rough-in frames should be installed before mounting and wiring the master station.

Refer to the installation instructions packaged with the

rough-in frame for detailed wiring information. For more detailed information on wiring and mounting other system components (i.e., speakers, remote controls, etc.), refer to the installation instructions packaged with each separate component.

IM-5006 SERIES REPRESENTATIVE WIRING ILLUSTRATION

Use this diagram for reference only—see IR-510 rough-in frame installation instructions for detailed wiring.

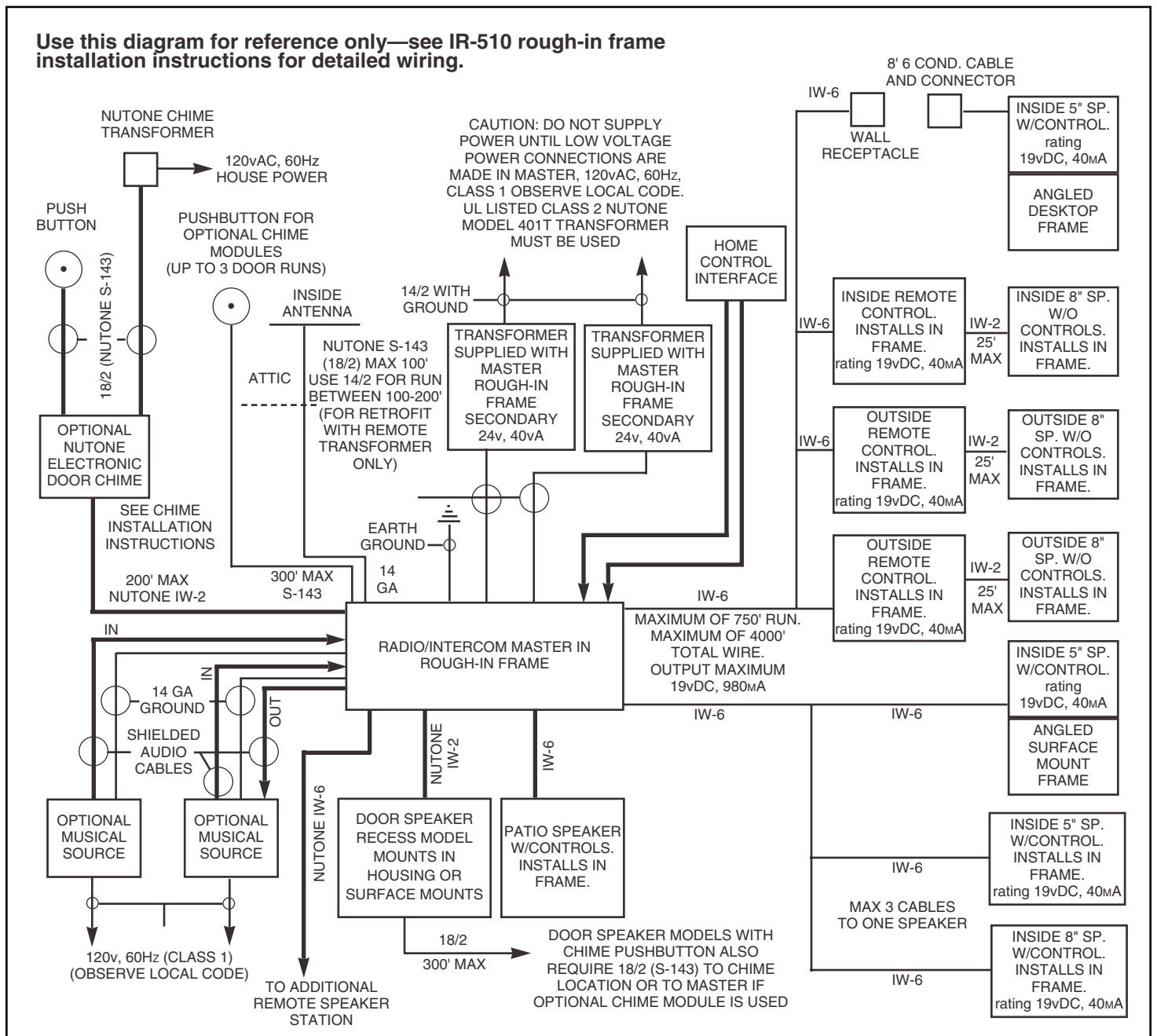

PACKAGING

IMPORTANT: Before discarding carton, check for the **Hardware Bag** that contains the following:

- Four (4) mounting screws for Master Unit.
- Two (2) hinge screws.
- Four (4) mounting brackets.
- Eight (8) mounting bracket screws.

WIRING INSTALLATION GUIDELINES

Wiring Specifications

NOTE: The system may be home run or loop wired with a maximum of six (6) runs terminated at the master. Also, three (3) runs (maximum) terminated at any one remote station.

NuTone IW-2: 22 GA. Twisted Pair.

NuTone IW-6: 22 GA. 3-twisted pair cable.

NuTone S-143: 18 GA. 2-conductor insulated.

No. 14/2: 120v, 60Hz Power Cable: Class 1, U.L. Listed (not supplied by NuTone).

14 GA.: Ground wire (not supplied by NuTone).

Speaker Wiring

An individual 6-wire cable (IW-6) must be connected to each remote speaker or remote control.

Maximum speaker run: 750 feet.

Maximum total of IW-6 per system: 4000 feet.

Maximum number of speakers: The system will accommodate up to 24 remote stations plus up to three (3) door speakers.

Maximum number of remote stations per run: 12.

NOTE: For best results it is suggested that the Intercom System is installed in such a way that a combination of “Home Run” wiring and “Looped” wiring (zone wiring) are both used.

Take a moment and refer to the following wiring examples.

Maximum Number of Speakers

The Intercom System will accommodate up to twenty-four (24) remote speakers.

IMPORTANT: NuTone cannot be responsible for improper radio-intercom operation that results from interference generated by light dimmers, fluorescent lighting fixtures, and similar electrical products, such interference must be corrected at the source. As an aid to help reduce this interference, all remote speaker, door speaker, chime and security alarm cables must be placed at least 12 inches from any A.C. power wiring.

The Intercom System is designed to be used only with NuTone specified wire. No other wire should be used. The use of wire other than NuTone wire may result in faulty installation and improper operation.

- Total output current rating: 19vDC 980mA.
- Current consumption each of the remote units: 19vDC 40mA.
- 980mA should not be exceeded.

SUGGESTED WIRING EXAMPLE

INSTALL THE SYSTEM LIKE THIS:

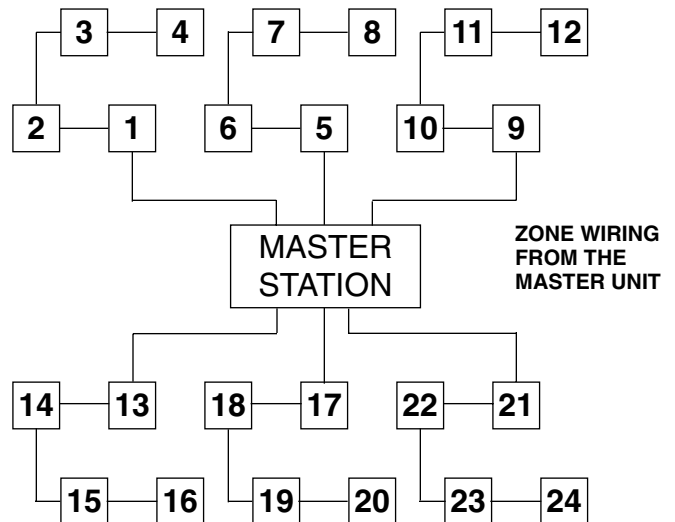

NOTE: ALTHOUGH THE IM-5006 MAY BE INSTALLED IN EITHER A HOME-RUN OR LOOPED CONFIGURATION, IT IS SUGGESTED THAT THE ABOVE ILLUSTRATION IS USED AS A GUIDELINE TO AVOID MASSIVE AMOUNTS OF WIRE AT THE MASTER STATION LOCATION.

INSTALLATION

Terminating the Wiring at the Master Panel

Refer to Figure 1.

1. Dress the speaker wire (NuTone Model: IW-6) thru the oblong hole in the top of the master unit's rough-in frame.
2. Cut the speaker wire to allow approximately 2' of wire to extend thru the top of the rough-in frame.

Refer to Figure 2.

3. Strip 6" of the outer insulation from each piece of speaker wire.

Refer to Figure 3.

4. Using a piece of tape or a wire tie, bind the speaker wiring together.

Refer to Figure 4.

5. Separate and cut the speaker wire into color groups.

Refer to Figure 5.

6. Strip 3/8" of insulation from each strand of speaker wire.

Refer to Figure 6.

7. Using a pair of pliers, twist the bare end of each colored set together.

Refer to Figure 7.

8. When this procedure has been completed, the speaker wire is ready for connections at the Master Unit location.

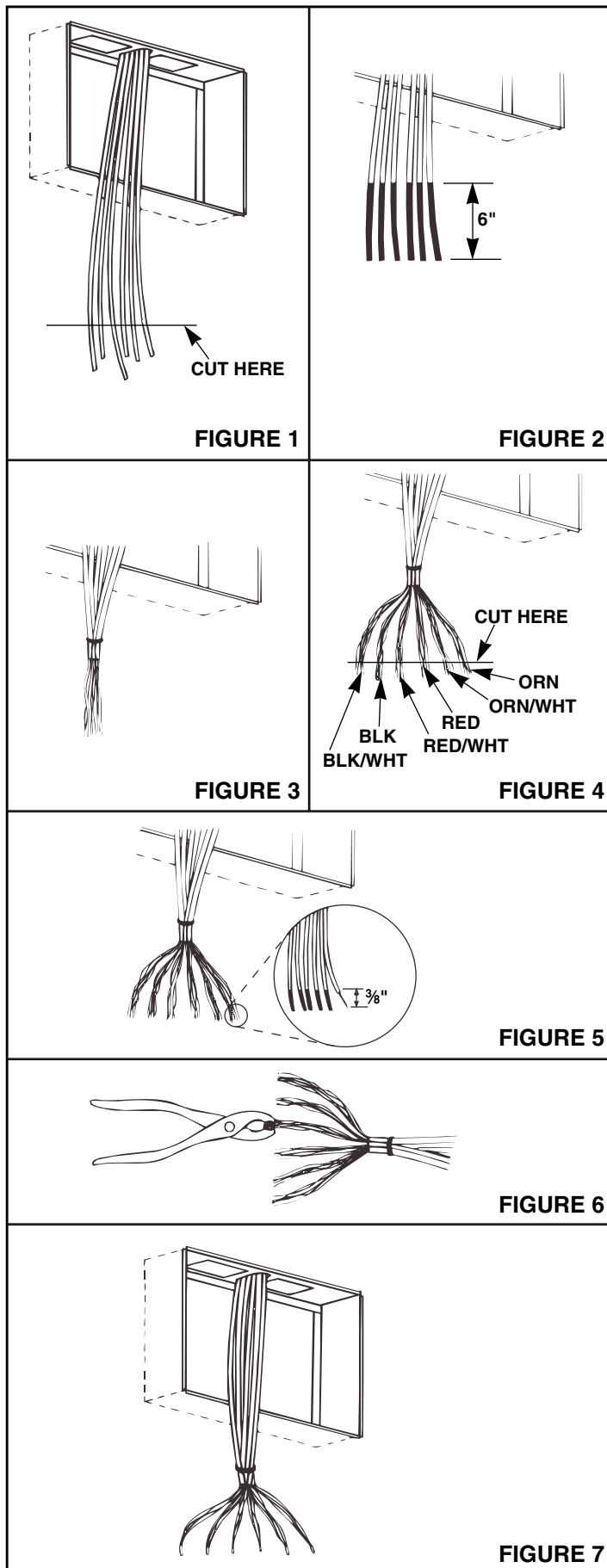

INSTALLATION (Continued)

Attaching the Master Panel to the Rough-in

Refer to Figure 8.

1. Use two No. 6 x 3/8" screws to attach mounting brackets to the top and bottom of rough-in frame. **Make sure brackets are flush to wall or rough-in.**

Refer to Figures 9 & 10.

2. For rough-in frames which are recessed into the wall opening. Insert two shoulder screws (provided) into the front two holes in the rough-in frame. For rough-in frames which are mounted flush with the wall. Insert two shoulder screws (provided) into the back two holes in the rough-in frame.

Refer to Figure 11.

3. Attach master panel to rough-in frame by placing keyhole slots in both mounting hinges over screw heads in rough-in frame.

Refer to Figure 12.

4. Slide master panel to the right, then forward until panel is flush with the wall.

Refer to Figure 8.

5. Attach support strap to rough-in by placing hook into hole in rear flange of rough-in frame.

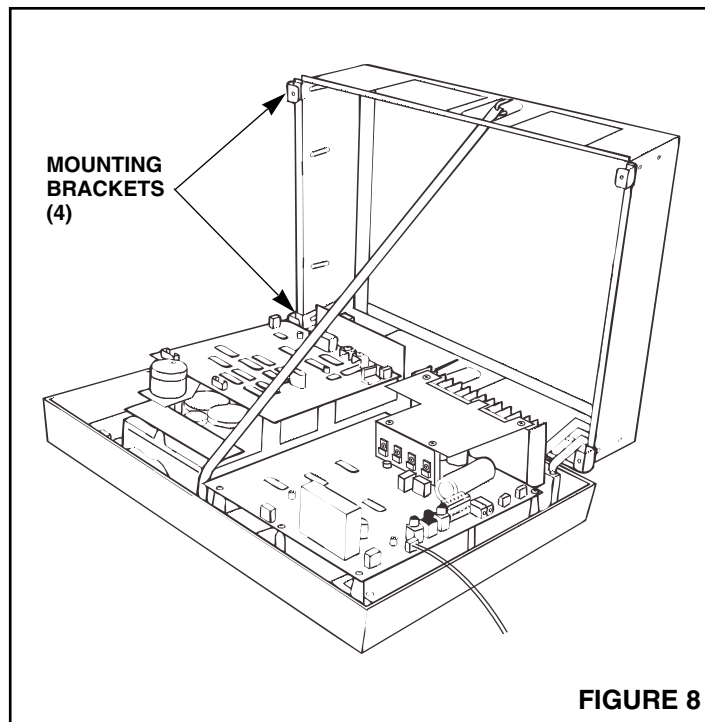

FIGURE 8

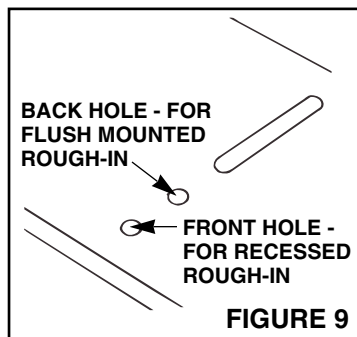

FIGURE 9

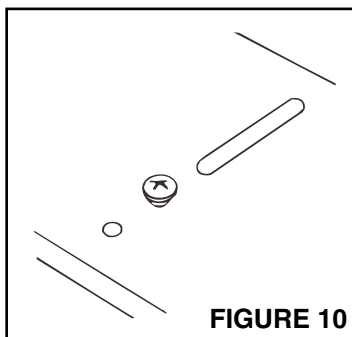

FIGURE 10

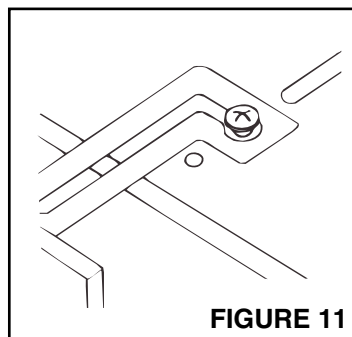

FIGURE 11

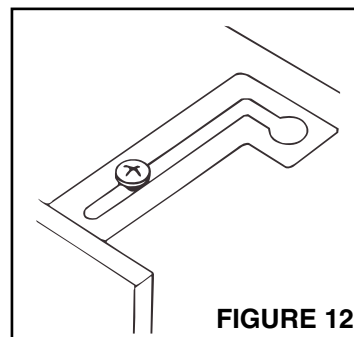

FIGURE 12

Connecting the Transformers

WARNING: Before any connections are made to the transformers, power must be disconnected at the main circuit breaker.

1. The transformer's primary leads should already be connected to the 120vAC house supply wires.
2. Two (2) sets of low-voltage supply leads are located in the bottom center section of the master unit. Connect one pair of supply leads to each transformer located in the bottom of the Rough-In.
3. Dress the wires and secure the box with two (2) screws for each box as illustrated in the rough-in installation instructions.
4. Connect the ground wires from the master unit to one of the transformer boxes mounting screws.
5. For installation of transformer, refer to manual for IR-510 Rough-In Frame.

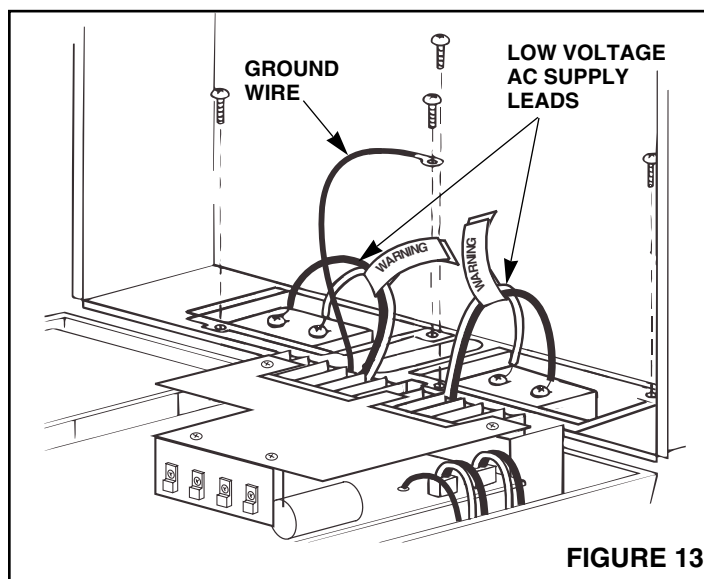
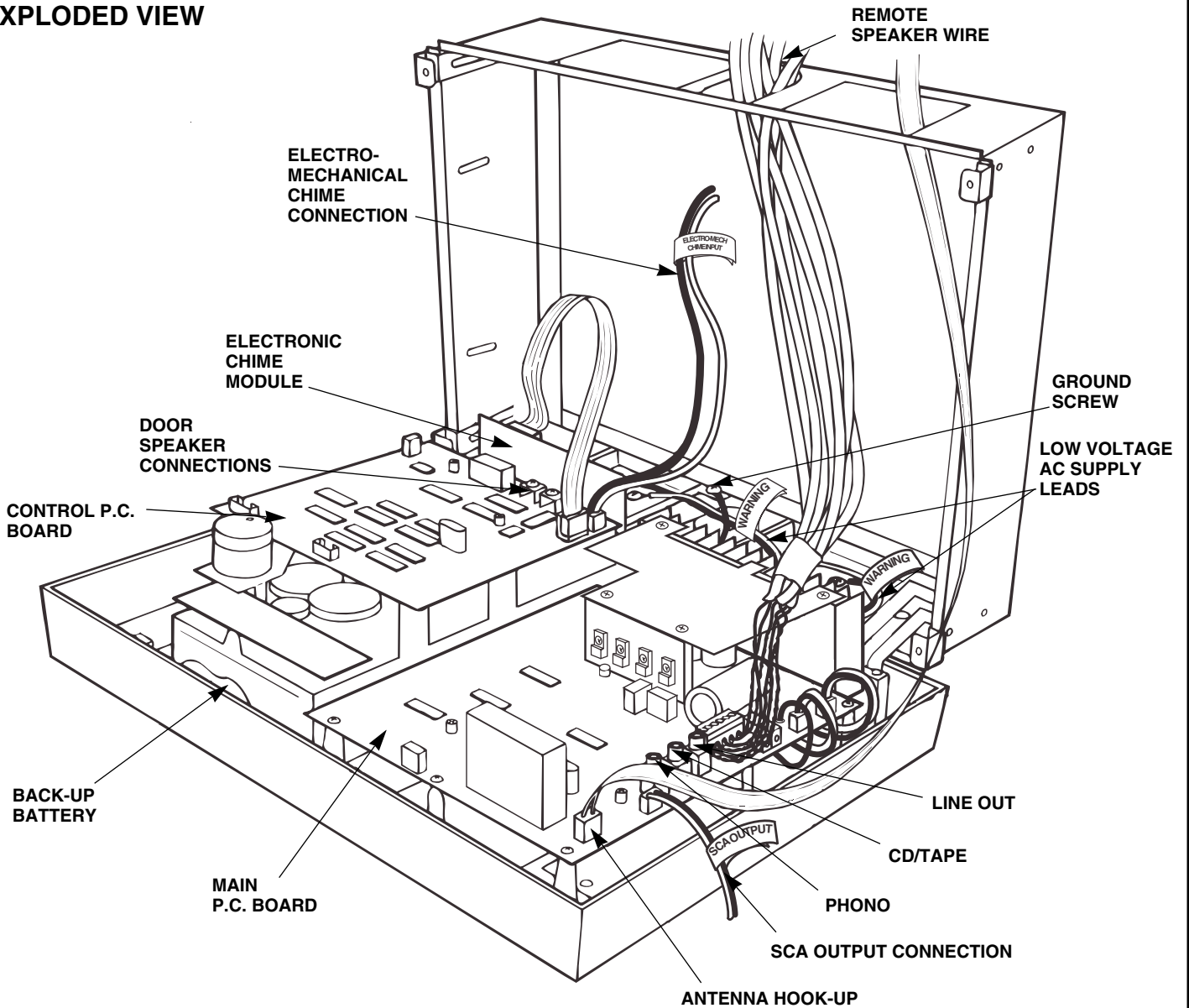

FIGURE 13

INSTALLATION (Continued)

EXPLODED VIEW



*SCA OUTPUT IS USED FOR AUDIO. SUBCARRIER INCLUDED IN FM RADIO BY CONNECTING THE SUBCARRIER ADAPTER

FIGURE 14

Connecting the Remote Speakers

1. Refer to page 3 of these instructions for information on terminating the speaker wire at the Master Station.
2. Refer to Figure 15. Connect the speaker wires to the terminal block located on the main P.C. board.

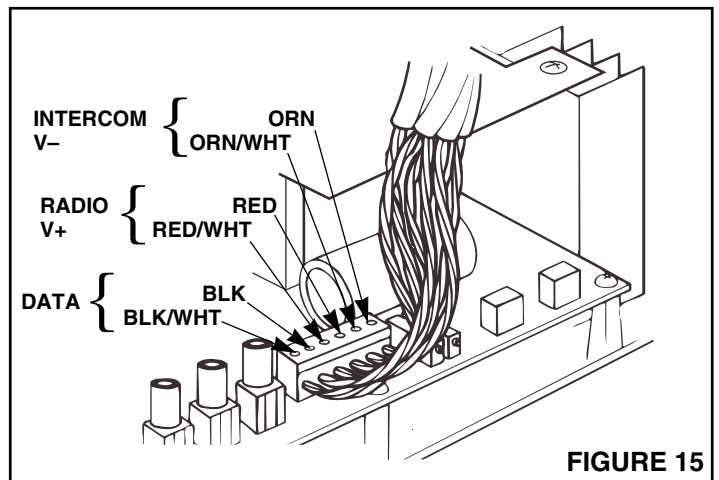

FIGURE 15

INSTALLATION (Continued)

Connecting the Door Speakers

1. The door speaker connects to the Control P.C. board of the master station with 2-conductor, 22 gauge twisted pair wire (IW-2).
2. As illustrated, connect two wires from the door speaker to the two (2) terminals marked DOOR SPEAKER on the P.C. board.

NOTE: When a door speaker that includes a pushbutton is used with the system, two (2) additional wires must be run from the speaker location to the master unit for chime pushbutton operation.

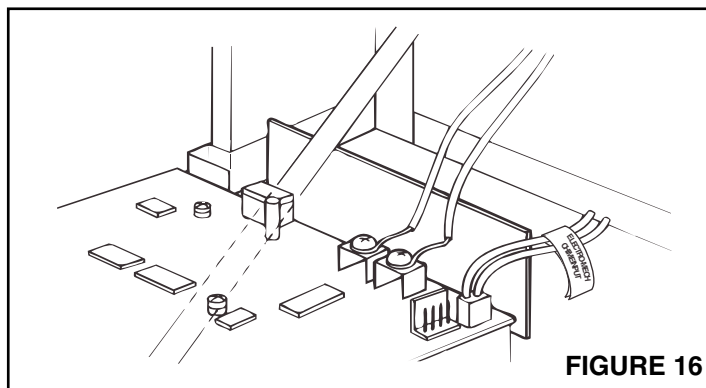

FIGURE 16

Connecting the Antenna

1. As illustrated in Figure 14, connect the Antenna to the 2-pin connector located in the upper right corner of the Main P.C. Board.
2. Refer to the instructions packaged with the Antenna for placement of the Antenna.

Connecting the Optional Electronic Chime Module

MODELS IA-28 OR IA-29

1. Connect wires from door switches – front, rear and side – to chime module. **NOTE:** Refer to the instructions packaged with the chime module.
2. Install fische paper backing onto the chime module. As illustrated, an additional hole must be cut in the fische paper.
3. Refer to Figure 14 to locate the chime module mounting bracket behind the Control P.C. Board.
4. Align the holes in the chime module with the pins on the mounting bracket. Apply firm, even pressure to each side of the chime module. The chime module will snap into place.

FOR MODEL IA-29 ONLY

5. Locate the chime selector switch mounting bracket.
6. Remove the chime selector switch retaining screw.
7. Slide the chime selector switch into the notch and re-install the retaining screw.

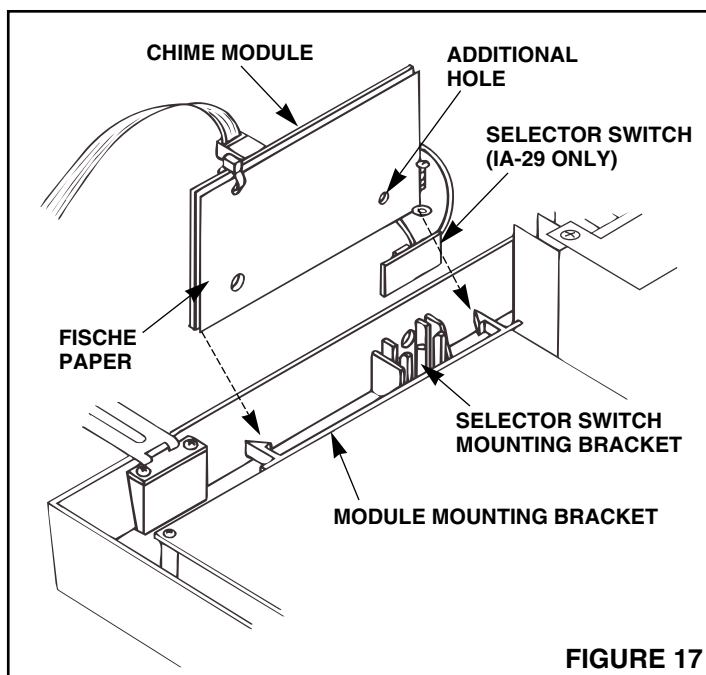

FIGURE 17

INSTALLATION (Continued)

Connecting the Optional Electro-Mechanical Chime

Refer to Figure 18.

1. Connect NuTone IW-2 cable from the chime to the red and white wires, labeled Electro-Mech Chime Input.
2. Refer to the Installation Instructions packaged with the chime for complete wiring information.

IMPORTANT: FAILURE TO USE NUTONE IW-2 CABLE WILL CAUSE THE SYSTEM TO HUM AT ALL TIMES.

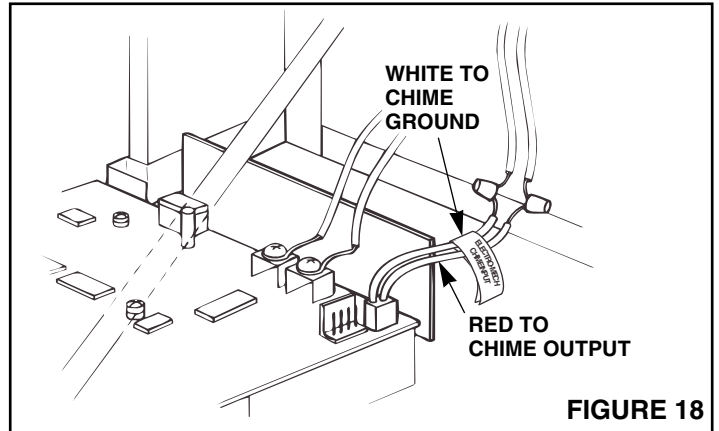

FIGURE 18

Back-up Battery Connection

Refer to Figure 19.

1. Connect the back-up battery as illustrated.

NOTE: The back-up battery retains the correct time, alarm time, intercom name list, radio station memory and note location for approximately 40 hours. If you plan to have 120vAC power off for a longer period of time, the battery should be disconnected.

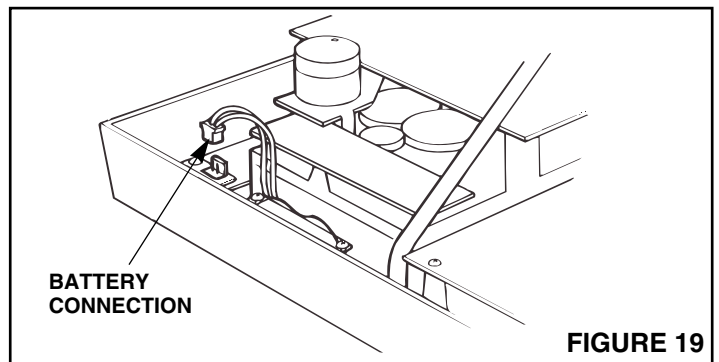

FIGURE 19

Connecting Line Out, CD/Tape Input, Phono Input

Refer to Figure 20.

NOTE: Use shielded cable with RCA type connectors (not supplied by NuTone).

1. To connect an optional record changer, cassette or CD player, locate the PHONO IN, TAPE IN and LINE OUT jacks on the right side of the main circuit board.
2. To play a phonograph thru the intercom system, insert the accessory's output plug into the master panel's PHONO IN jack.
3. To play the CD or tape player thru the intercom system, insert the accessory's output plug into the master panel's CD/TAPE IN jack.
4. To use the radio as a program source for recording onto a cassette recorder, insert the tape recorder's input plug into the master panel's LINE OUT jack.
5. **OPTIONAL HOOK-UP TO PROVIDE RADIO ONLY:**

The radio and optional entertainment source can be channeled through an auxiliary amplifier (purchase NuTone Model: IMA-516 separately) to provide uninterrupted music (no intercom) to separate speakers. This type of installation can be used for a doctor's office, where intercom and music are desired in the office area, but music only in the waiting room.

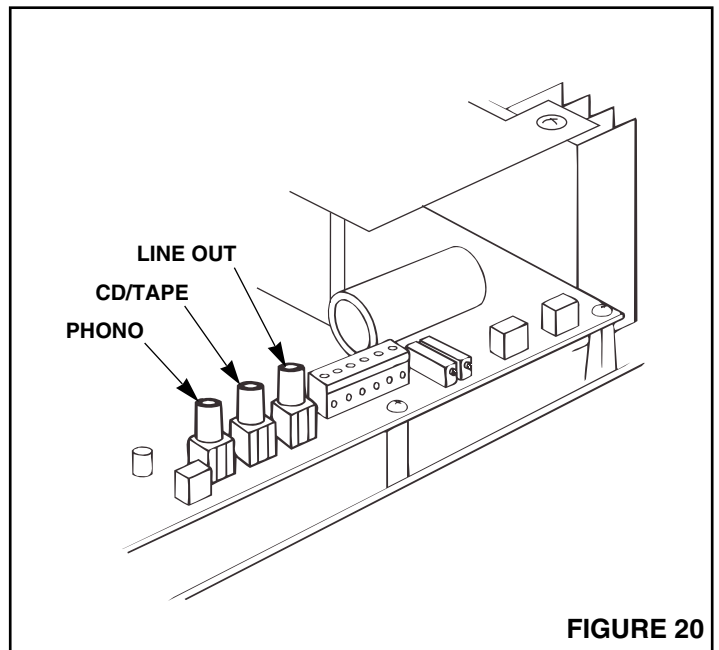

FIGURE 20

NOTE: If an auxiliary amplifier is used, connect the master station's line out jack to the auxiliary amplifier's low-level radio input wire.

INSTALLATION (Continued)

Securing the Master Panel

1. Check all wiring connections to make sure they are complete and correct.
2. Check to make sure antenna connection is secure.
3. Position the Master Panel over rough-in frame and align screw holes in Master Panel with rough-in frame.
Dress the wires carefully on both sides of the panel so as to prevent them from being pinched when closing the panel.
4. Secure the Master Panel to rough-in with four (4) screws provided.

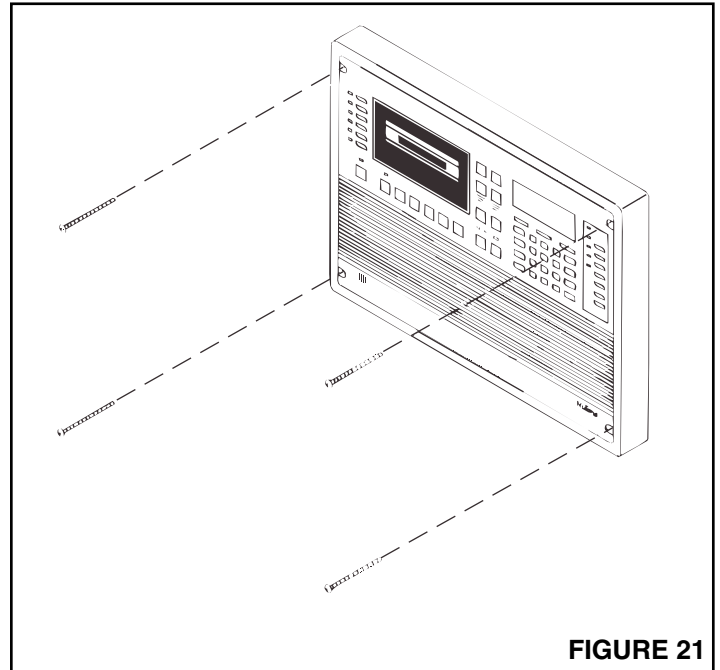

FIGURE 21

General Intercom Operation

NOTE: Refer to the homeowner's manual for complete information on the intercom operation of this system.

1. When an intercom call is initiated, a CALL TONE will be heard at the station from which the call is placed as well as the station that is being called. **NOTE: If one of these stations is a door speaker, a CALL TONE will not be heard at that location.**
2. The station that is being called will be in the "hands-free" mode.
3. The intercom volume is adjusted by using the intercom volume UP-DOWN keys and may only be adjusted during an intercom call. The radio volume cannot be adjusted at a station that is participating in an intercom call.
4. When an intercom call is in progress, the BUSY light will be lit at stations not participating in the communication. An intercom call cannot be initiated from a station when the busy light is lit.

OPERATIONAL CHECKOUT

NOTE: Please refer to page 10 for a convenient Operational Checklist.

1. When the system is first powered up, the display will appear as 12:00 AM. To ensure that no incorrect data has been stored in the system's memory during shipment and/or installation, a total system reset should be done at the master station by simply pressing * 8# at the master station's keypad.
 2. Select FM radio and tune to a radio station that has a strong signal by using the following procedure:
 - A) **Press the ON/OFF key** - the LED next to the key will be lit.
 - B) **Press the FM key** - the LED next to the key will be lit and FM 87.9 will appear in the display.
 - C) Tune to a station by pressing the < or > key at the master station.
- Beginning with the master station, use the following procedure at each station to check for proper operation:**
1. Adjust the radio volume keys to be certain the volume is operating properly.

NOTE: The radio audio cannot be turned completely off at the master station by using the radio volume key; the mute key must be used.
 2. **Press the PRIVATE key;** the PRIVATE LED will be lit and the station will be in the private mode.

In the private mode, the station cannot accept an intercom call.
 3. **Press the PRIVATE key** again and the PRIVATE LED will go out and the station will again be able to accept intercom calls.
 4. **Press the MONITOR key;** the MONITOR LED will be lit and audio from this station will be heard at all of the other stations.
 5. **Press the MONITOR key** again and the MONITOR LED will go out and the station will no longer be in the monitor mode.
 6. **Press the ALL CALL key;** the ALL CALL LED will be lit at this station. A call tone will be heard at every station in the system. Radio audio will be muted and audio from every station will be heard at the station that initiated the all call.

The intercom volume key may be used to adjust the audio at the initiating station. **NOTE: The intercom volume cannot be completely muted.**
 7. **Press the TALK key.** Audio from the initiating station will be heard at all the stations in the system.

When the TALK key is released, audio from the other stations will be heard at the initiating station.
 8. **Press the END CALL key** and the ALL CALL LED will go out at the initiating station. The radio audio will now be heard at all stations.
 9. **Press the DOOR key;** the DOOR LED will be lit at the initiating station and the BUSY LED's will be lit at each of the other stations. A call tone will be heard at the initiating station only; not at the door speaker. Audio from the door speaker will be heard at the initiating station.
 10. **Press the TALK key.** Audio from the initiating station will be heard at the door speaker.

When the TALK key is released, audio from the door speaker will be heard at the initiating station.
 11. **Press the END CALL key.** The DOOR LED will go out at the initiating station and the BUSY LEDs will also go out at all of the other stations. The radio audio will now be heard at the initiating station.
 12. Use the following procedure to initiate a "select" intercom call:
 - a) Using the station's keypad, call another station in the system.

NOTE: When a station has been assigned a station code of one digit (1-9), the code must be entered with a zero (0) preceding the assigned number. Example: to call station #2, press 02 on the key pad. When the second digit is entered, a call tone will be heard at the station that initiated the call as well as at the station that has been called. Radio audio will be muted at both of these stations.
 - b) The BUSY LED will be lit at all other stations; audio from the station that has been called will be heard at the station that initiated the intercom call.
 - c) **Press the TALK key.** Audio from the station that initiated the intercom call will be heard at the station that has been called.
 - d) **Release the TALK key.** Audio from the station that has been called will be heard at the station that initiated the intercom call.
 - e) **Press the END CALL key.** The radio audio will be heard at both stations. The BUSY LED's will go out at all other stations in the system.
 - f) Continue to check the system by making select intercom calls to each speaker location.

OPERATIONAL CHECKOUT (Continued)

Operational Check List

At the time of installation, NuTone recommends that the following check list is used to verify that the system is operating properly.

Station Number	Radio Volume	Private	Monitor	All Call	Intercom Volume	Talk	End Call	Door Call	Select Call	Location
01										
02										
03										
04										
05										
06										
07										
08										
09										
10										
11										
12										
13										
14										
15										
16										
17										
18										
19										
20										
21										
22										
23										
24										
25										

Notes:

OPERATIONAL CHECKOUT (Continued)

Setting the Radio Audio Level

In most installations, the audio trimpot will not need to be adjusted. However, follow these steps if an adjustment is necessary.

1. Set the radio volume control to the maximum level at the remote speaker located closest to the master station.
2. Set the radio volume to the OFF position at the other remote stations.
3. Select a strong FM station at the master station.
4. Mute the radio at the master station by pressing the **MUTE** key.
5. Use a small thin-bladed screwdriver to adjust the radio audio trimpot until the audio at the remote speaker is at the desired level. **NOTE:** If the radio audio is increased to a high level, the radio volume may be too loud at even the lowest setting at the remote speaker locations.
6. The radio volume control at all remote speaker locations and at the master unit location may now be adjusted to the desired level with no further adjustment to the radio audio trimpot.

Setting the Intercom Audio Level

In most installations, the intercom audio trimpot will not need to be adjusted. However, follow these steps if an adjustment is necessary.

1. At a remote speaker location, ask someone to speak to someone else at the master station location.
2. Set the intercom volume control at the master station to the maximum level. **NOTE:** The intercom volume may only be adjusted when the system is in the intercom mode.
3. Use a small thin-bladed screwdriver to adjust the intercom audio trimpot until the audio level is at the desired level.
4. The intercom volume control at all remote speaker locations and at the master unit location may now be adjusted to the desired level with no further adjustment to the intercom audio trimpot.

Setting the Door Speaker Volume Level

In most installations, the door speaker volume will not need to be adjusted. However, follow these steps if an adjustment is necessary.

1. Locate the door speaker volume trimpot on the master station's Control P.C. Board.
2. Call a door speaker from the master station location. Press the **TALK** key and speak in a normal voice.
3. Adjust the door speaker volume trimpot until the desired door speaker volume level is achieved. **NOTE:** This setting controls the audio level to the door speaker only.

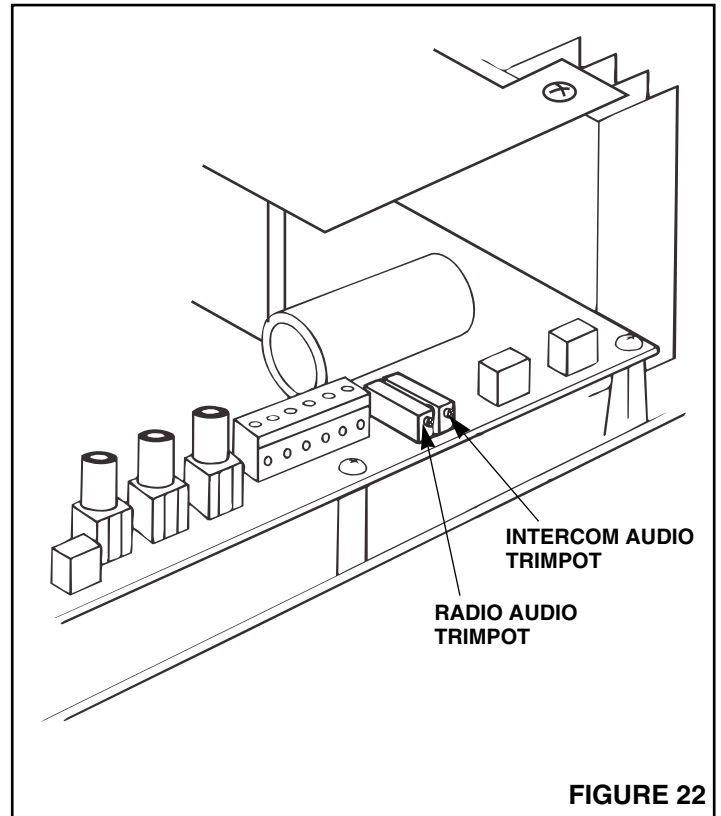

FIGURE 22

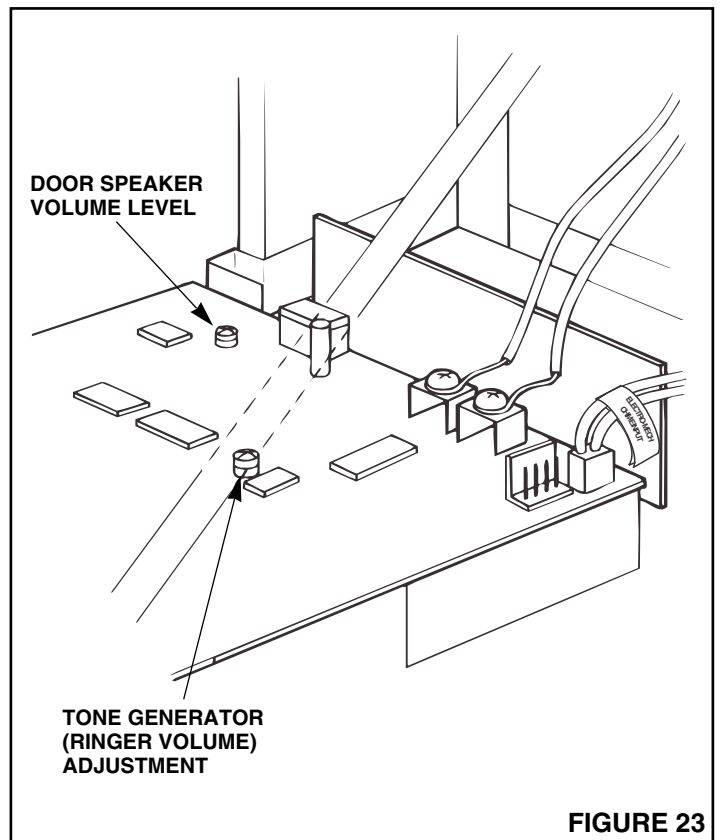

FIGURE 23

OPERATIONAL CHECKOUT (Continued)

Tone Generator Volume Adjustment

The tone generator creates the tones that are heard from each station (call tone, alarm tone, feed back tone, etc.)

A trimpot is located on the master station and on each of the remote speakers.

To adjust the trimpot at the master station:

1. Enter an invalid keypad entry; Example: 3.

2. Adjust the trimpot to the desired level using a small screwdriver.

NOTE: Do not turn the tone generator completely off; the alarm function will be disabled.

NOTE: The trimpot on the remote station's is located next to the black wire connection terminals and is labeled ringer volume.

If you should encounter problems with the Intercom System

If your Intercom System is not operating properly, the Internal Microprocessor might need to be reset. Four (4) levels of reset have been incorporated into the Intercom System:

Begin with Level 1 and proceed to the next level until the problem has been corrected.

NOTE: Levels 2, 3 and 4 will erase the system's memory and defaults the system back to the original factory preset.

LEVEL 1: To reset a station, press *9# on the station's keypad.

When this level of reset is performed at the master station, the master station will be reset but any information that has been stored in the master station's memory will not be erased.

When this level of reset is performed at a remote speaker location, that location will be reset but any information that has been stored into the station's memory will be erased.

LEVEL 2: To totally reset the system, press *8# on the master station's keypad. All stations in the system will be reset and any stored information will be erased from the system's memory.

LEVEL 3: If unit does not respond to a Level 1 or 2 reset, locate the Power Reset Button on the bottom left side of master station. A label marked "For Power Reset Only" will be covering the access hole. Using a pencil, punch a hole in the label and activate button. The master station will reset, and information stored at the master station will be cleared.

LEVEL 4: IMPORTANT: IF YOU ARE NOT CERTAIN AS TO THE CORRECTNESS OF ANY STEP OR PROCEDURE DESCRIBED HERE, SECURE THE SERVICES OF A QUALIFIED TECHNICIAN.

NOTE: This level should only be used after all other levels have been attempted and will involve the partial removal of the intercom's master unit from the rough-in frame.

1. Disconnect AC power from the system.
2. Remove the four (4) mounting screws from the master station's front panel.
3. Slowly lower the master station towards yourself. Be careful not to catch any wires on the rough-in frame. Let the unit rest on the support strap in a face-down position.
4. Disconnect the back-up battery from the master station. Refer to page 7 of this booklet.
5. When two (2) minutes have elapsed, reconnect the battery.
6. Carefully dress the wires and re-install the master unit into the rough-in frame.
7. Restore AC power to the system. If the system has properly reset, the display will appear as 12:00 AM.
8. If the system is not operating properly, disconnect the AC power and notify a NuTone service representative.

OPERATIONAL CHECKOUT (Continued)

Setting The Remote Speaker Switches

IMPORTANT: The Master Station has been preset as Station #1. The Remote Speakers will be stations 02 through 25.

1. **Refer to Figure 24.** Locate the Selector Switch on the back of the remote control unit.
2. **Refer to Figure 25.** As indicated in Figure 2, set the Selector Switch in the ON and OFF positions.

IMPORTANT: Outdoor models must be caulked with a waterproofing compound (Silicone Rubber, RTV or equivalent – not supplied by NuTone). Caulk across the top and both sides of the unit only; the bottom of the unit should not be caulked.

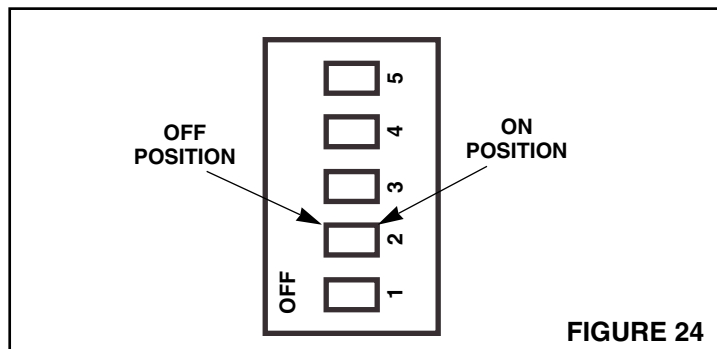

FIGURE 24

IF THE REMOTE UNIT IS TO BE THE STATION NUMBER:	THESE NUMBERS ON THE SELECTOR SWITCH MUST BE IN THE ON POSITION
02	2
03	1 & 2
04	3
05	1 & 3
06	2 & 3
07	1, 2 & 3
08	4
09	1 & 4
10	2 & 4
11	1, 2 & 4
12	3 & 4
13	1, 3 & 4
14	2, 3 & 4
15	1, 2, 3 & 4
16	5
17	1 & 5
18	2 & 5
19	1, 2 & 5
20	3 & 5
21	1, 3 & 5
22	2, 3 & 5
23	1, 2, 3 & 5
24	4 & 5
25	1, 4 & 5

FIGURE 25

INSTALLER'S TROUBLESHOOTING GUIDE

TROUBLE	POSSIBLE CAUSE	POSSIBLE REMEDY
Hum in remote speakers.	The intercom wiring has been run too close to the household AC power wiring.	Be certain the intercom wiring is as far away as practical from the household AC power wiring. Do not run the intercom wiring parallel to the AC power wiring.
	Wire installation.	Check the ORN, ORN/WHT, RED, RED/WHT wires for shorts or opens at the master station and at each remote speaker location.
	Interference from household electrical fixtures.	A dimmer or fluorescent light may cause interference. Filters should be used for dimmer or fluorescent light interference (G.E. 89G635 or equivalent – purchase locally).
A select call from the master station to a remote station is not functioning (but the radio operates properly at each remote speaker location).	Wire installation.	Check BLK, BLK/WHT (serial data) wires to be certain they are properly connected to the master station and each remote speaker location.
	*Improperly set station code selector switch.	Check to make sure the station code has been set at all stations and no two stations have the same station code.
No radio or intercom from the remote speakers (Radio operates properly at the master station).	Improper wiring installation at the master station.	Check the wiring going to the remote speaker connector at the master station.
	No electrical power to the remote speakers.	Be certain 120vAC, 60Hz power has been provided to the primaries of both 401T transformers.No less than 24vAC should be measured on the secondary of either transformer.
	Defective transformers.	Replace transformer.
Remote speakers may communicate with each other but the master station does not function.	No electrical power to master station.	Be certain 120vAC, 60Hz power has been provided to the primaries of both 401T transformers.No less than 24vAC should be measured on the secondary of either transformer.
	Defective transformer.	Replace transformer.
No door communication.	Wire installation.	Check the wires to door terminals at door speakers and at the master station.
		Check BLK, BLK/WHT (serial data) wires to be certain they are properly connected to the master station and each remote speaker location.
	Speaker.	Check the continuity of the door speaker.
	Incorrect door speaker volume setting.	Follow “Setting Door Speaker Volume Level” instructions in this booklet. NOTE: This setting effects only the audio going to the door speaker.
Cannot receive a radio station that is being received by another radio in the home.	Faulty antenna connection.	Be certain the antenna connector is properly connected to the antenna pins located in the upper right corner of the master station.
	Improper antenna installation.	The antenna should be located in the attic (refer to the antenna instructions).
The master station will not go into the note mode.	A cassette tape has not been put into the master station.	Place dedicated message tape into the master station.
	Recording lockout tabs have been removed from cassette tape.	Cassette tape that has recording lockout tabs must be used. Or place a piece of masking tape over the holes located in the two (2) corners of the tape.

INSTALLER'S TROUBLESHOOTING GUIDE (Continued)

TROUBLE	POSSIBLE CAUSE	POSSIBLE REMEDY
The radio volume is too loud when the remote speakers are set on the first volume step.	Improper setting of the program audio trim pot.	Decrease the radio audio level by turning the program audio trimpot (counter clockwise) until the desired audio level has been achieved with the remote speaker set in their first volume step (refer to "Setting the Radio Audio Level").
The system squeals when the intercom is being used.	The speaker in the adjacent room(s) is mounted on a common wall (back to back).	If the remote speakers have been mounted back to back, one of them will have to be relocated. If the speakers are on a common wall, place fiberglass insulation behind each speaker or isolate the speaker from the wall by placing rubber washers or weather stripping between the speaker and the wall surface.
Static.	Loose ground connection.	Check the ground connection to the master station and the connection to the earth ground source.
	Interference from household electrical fixture.	A dimmer or fluorescent light may cause interference. For dimmer or fluorescent light interference, use filters (G.E. 89G635 or equivalent, purchase locally).
	Interference from household electrical appliances.	Correct interference at the source: fishtank heater, hand tools, coffee pot, etc.
	Wire installation.	Check all wiring in the system: speaker, chime, and transformer connections at master station and connection at remote speakers.
Optional Electronic Chime (Models IA-28 or IA-29) does not operate or operates at a low level.	Wire installation.	Be certain the chime is properly connected to the master station. Also, be certain the front, side and rear buttons are properly connected to the chime board.
	Improper volume setting.	Adjust the volume of the chime module by turning the volume potentiometer located on the chime module behind the 4-pin ribbon cable connector. NOTE: It may be necessary to remove the chime module from the master station to make this adjustment.
	Wire installation.	Check the door terminals on the chime module by shorting the common terminal to each of the door terminals front, rear and side. The chime should play.
Mechanical chime can't be heard through the master station or remote speakers.	Wire installation.	Be certain the mechanical chime is properly connected to the master station's mechanical chime input wires located next to the electronic chime 4-pin connector on the audio control PC board.
	Improper volume setting.	Adjust the volume of the mechanical chime by turning volume potentiometer, located on the mechanical chime pick-up.
Call tone volume at a station is too loud.	Call tone volume trimpot is not adjusted properly.	Refer to call tone volume adjustment in the home owner's instructions. If volume is still not desirable refer to tone generator adjustment on page 12. NOTE: It is suggested that the tone generator volume not be adjusted to the off position.

***IMPORTANT: Be certain the system has been disconnected at the main power source prior to setting the selector switch. Powering the system up will allow the station identification to be effective.**

NuTone[®]

Two Year Limited Warranty

WARRANTY OWNER: NuTone warrants to the original consumer purchaser of its products that such products will be free from defects in materials or workmanship for a period of two (2) years from the date of original purchase. **THERE ARE NO OTHER WARRANTIES, EXPRESS OR IMPLIED, INCLUDING, BUT NOT LIMITED TO, IMPLIED WARRANTIES OF MERCHANTABILITY OR FITNESS FOR A PARTICULAR PURPOSE.**

During this two year period, NuTone will, at its option, repair or replace, without charge, any product or part which is found to be defective under normal use and service. **THIS WARRANTY DOES NOT EXTEND TO FLUORESCENT LAMP STARTERS OR TUBES, FILTERS, DUCT, ROOF CAPS, WALL CAPS AND OTHER ACCESSORIES FOR DUCTING.** This warranty does not cover (a) normal maintenance and service or (b) any products or parts which have been subject to misuse, negligence, accident, improper maintenance or repair (other than by NuTone), faulty installation or installation contrary to recommended installation instructions.

The duration of any implied warranty is limited to the one year period as specified for the express warranty. Some states do not allow limitation on how long an implied warranty lasts, so the above limitation may not apply to you.

NUTONE'S OBLIGATION TO REPAIR OR REPLACE, AT NUTONE'S OPTION, SHALL BE THE PURCHASER'S SOLE AND EXCLUSIVE REMEDY UNDER THIS WARRANTY. NUTONE SHALL NOT BE LIABLE FOR INCIDENTAL, CONSEQUENTIAL OR SPECIAL DAMAGES ARISING OUT OF OR IN CONNECTION WITH PRODUCT USE OR PERFORMANCE. Some states do not allow the exclusion or limitation of incidental or consequential damages, so the above limitation or exclusion may not apply to you. This warranty gives you specific legal rights, and you may also have other rights, which vary from state to state. This warranty supersedes all prior warranties.

WARRANTY SERVICE: To qualify for warranty service, you must (a) notify NuTone at the address stated below or telephone 1/800-543-8687, (b) give the model number and part identification and (c) describe the nature of any defect in the product or part. At the time of requesting warranty service, you must present evidence of the original purchase date.

Date of Installation

Builder or Installer

Model No. and Product Description

IF YOU NEED ASSISTANCE OR SERVICE:

For the location of your nearest NuTone Independent Authorized Service Center:

Residents of the contiguous United States Dial Free 1-800-543-8687

Please be prepared to provide:

Product model number • Date and Proof of purchase • The nature of the difficulty

Residents of Alaska or Hawaii should write to: NuTone Inc. Attn: Department of National Field Service, Madison and Red Bank Roads, Cincinnati Ohio 45227-1599.

Residents of Canada should write to: NuTone Canada Inc., 6300 Tomken Road, Mississauga, Ontario, Canada L5T 1N2.

Rev. 4/99