

### SELECTIVE CALL INTERCOM SYSTEM MODEL: IM-5000 MASTER STATION

This booklet contains information for wiring and installing the master station. All system wiring and remote station rough-in frames should be installed before mounting and connecting the master station.

Detailed information on wiring and mounting system components (i.e. speakers, remote controls, etc.) are packaged with each separate component.

### IM-5000 SERIES REPRESENTATIVE WIRING ILLUSTRATION

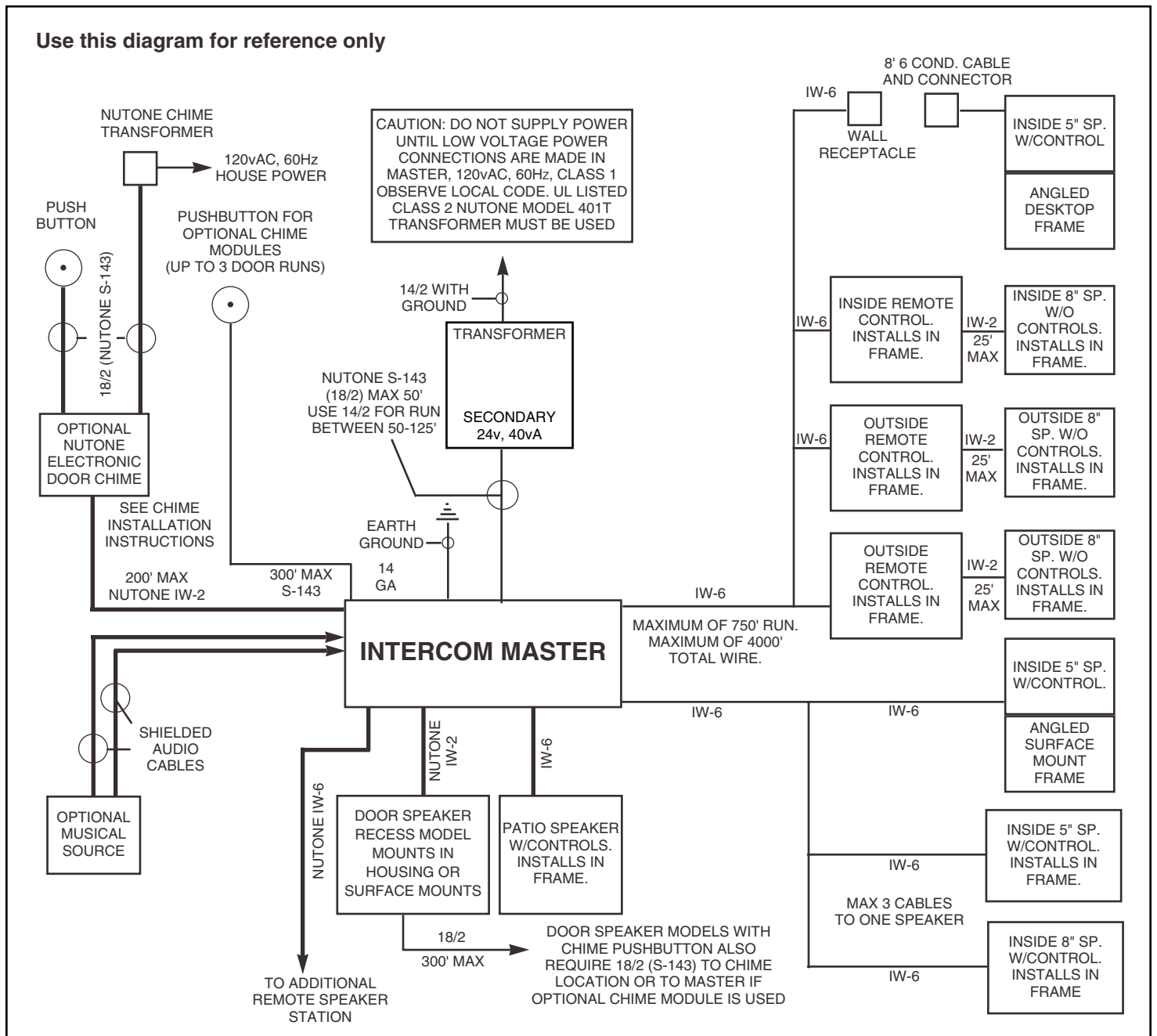

# IM-5000 SPECIFICATIONS

## CONTENTS OF CARTON

Check (✓) for the following IM-5000 carton contents:

- IM-5000 Selective Call Intercom
- Two (2) #8 x 1-1/4" wood screws
- Installation Instructions
- Homeowner's Manual
- Registration card

---

**Note to Installer:** Do not discard these instructions. Please give all installation instructions, warranty registration and homeowner's manual to homeowner.

---

## WIRING SPECIFICATIONS

**Use NuTone IW-6, 22 ga, 3-twisted pair for connecting:**

- Master to IC-502 remote controls
- Master to IS-515, IS-518 & IS-519 remote stations

**Use NuTone IW-2, 22 ga. twisted pair for connecting:**

- Door speakers
- Remote controls to speakers
- Electronic chime audio to master

**Use NuTone S-143, 18 ga. twisted pair for connecting:**

- Master to 401T power transformer
- Chime module or electronic chime to pushbutton
- Electronic chime to chime transformer

**Use 14 ga. ground wire (not supplied by NuTone) for connecting:**

- Master to ground

**Use shielded audio cable for connecting:**

- External audio source

## SYSTEM SPECIFICATIONS

- Power transformer: (1) NuTone 401T (24VAC @ 40VA)
- Maximum number of remote controls/stations: **20**
- Maximum number of door speakers: **3**
- Total system length of IW-6 cable: **4,000 ft.**
- Maximum remote station cable length: **750 ft.**
- Maximum IW-6 cables connected at master: **6**
- Maximum number of remote stations per run: **6**
- Total system length of IW-2 to door speakers: **750 ft.**
- Maximum length of IW-2 to electronic chime: **200 ft.**
- Maximum length of IW-2 from remote control to speaker: **25 ft.**
- Maximum length of S-143 for 401T power transformer: **50 ft.**
- Maximum length of S-143 for chime module pushbutton: **300 ft.**
- Maximum length of S-143 for electronic chime transformer: **50 ft.**
- Maximum length of S-143 for electronic chime pushbutton: **100 ft.**
- Maximum length of shielded audio cable: **50 ft.**

# PRECAUTIONS AND GUIDELINES

The NuTone IM-5000 Selective Call Intercom has been designed for ease of installation. Please read and follow ALL instructions, guidelines and precautions. Any deviation from these instructions or improper wiring will cause this unit to fail and all NuTone warranties will become void.

**WARNING:** Power from the circuit breaker must be **OFF** before connecting the 401T transformer and making any connections to the master unit!

**WARNING:** Power toggle switch in the master unit must be in the **OFF** position during ALL connections. Power LED indicator will remain out until power is applied at the circuit breaker and at the master.

- Observe all local regulations and codes in your area.
- Select a location for the master which has an ambient temperature range of 50 to 90°F. Do not mount the master in the attic or unheated space.
- All screw terminals at remote stations and master must be secure **BEFORE** power is applied.
- Observe all color codes of wires when connecting remote stations to master unit.
- NuTone will not be responsible for improper intercom/auxiliary audio source operation resulting from interference generated by light dimmers, fluorescent lighting fixtures and/or similar electrical products; such interference must be corrected at the source. **To reduce this interference, all remote stations, door speakers, chime and auxiliary audio cables must be placed at least 12 inches away from any A.C. power wiring.**
- The IM-5000 Intercom System is designed to be used with NuTone specified wire; no other wire should be used. **The use of wire other than NuTone wire will void all NuTone warranties and may result in faulty installation and improper operation.**
- Proper grounding of the master unit is **REQUIRED**. Use 14 ga. copper wire between master and ground connection.

# INSTALLATION INSTRUCTIONS

## INSTALLING CABLE TO THE MASTER LOCATION

The following instructions apply to all cable placements to the master unit.

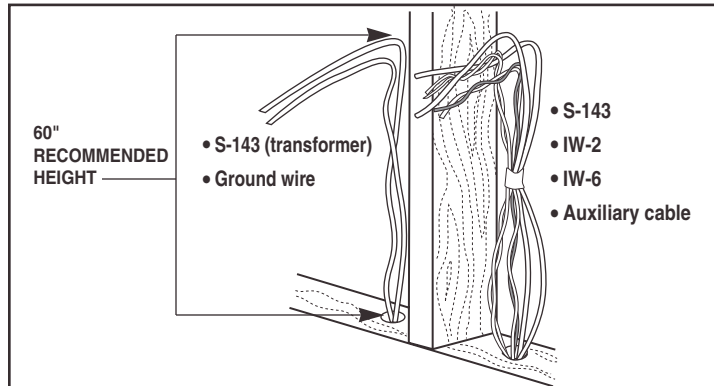

**IMPORTANT:** Keep all cabling at least 12" away from A.C. wiring.

**NOTE:** Select a location for the master which has an ambient temperature range of 50 to 90°F. Do not mount the master in the attic or unheated space.

Determine the location of the master unit. When positioning cables to exit the wall cavity, all cables must exit at the same height on the wall stud. The group of cables can exit at any height above 18"; however, NuTone recommends the cables exit at 60".

Expose a minimum of 24" of each cable from the wall cavity into the room to alert drywall installer to route through drywall.

For your convenience, it is recommended that each cable/wire be labeled to indicate the location and type of connected accessory (for example "S-143/Front Door Pushbutton").

**WARNING:** Turn power at circuit breaker and master unit off **BEFORE** making any connections at the master unit.

## Remote Station Cable (IW-6)

Run all speaker cables from the remote station locations to the master station location. Use the recommended wiring example when routing cable between remote station and master.

Position and secure the IW-6 cable on the **RIGHT HAND** side of the wall stud.

**REMEMBER:** A maximum of (6) IW-6 cables can enter the master unit.

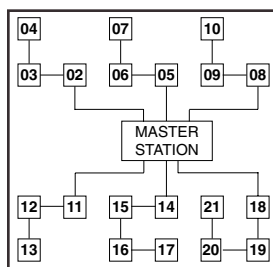

## Door Speaker Cable (IW-2)

Run all door speaker cables from the door speaker locations to the master station location. NuTone recommends home run installation of door speakers; however, they can be looped. Mark cables for later identification.

Position and secure the IW-2 cable on the **RIGHT HAND** side of the wall stud.

## Chime Pushbutton S-143 Cable for NuTone Chime Module (Optional)

Run all chime pushbutton cables for the chime module from the pushbuttons to the master station location.

Position and secure the S-143 cables on the **RIGHT HAND** side of the wall stud.

## Electronic Chime Audio IW-2 Cable to Master (Optional)

Run IW-2 cable from the electronic chime location to the master station location.

Position and secure the IW-2 cable on the **RIGHT HAND** side of the wall stud.

## Auxiliary Audio Source Shielded Cable to Master (Purchase Locally)

Run the audio source cable from the source location to the master station location. Maximum run length is 50 ft.

If the audio source is stereo, run a shielded audio cable for both the left and right channels.

Position and secure this cable on the **RIGHT HAND** side of the wall stud.

## Transformer S-143 Cable to Master

Run the S-143 transformer cable from the 401T transformer to the master station location. Transformer must be mounted at least 2 ft. away from master.

Position and secure the S-143 cable on the **LEFT HAND** side of the wall stud.

## Ground Wire (14 gauge copper) to Master

Run the ground wire from the earth ground connection in the circuit breaker panel to the master station location.

Position and secure the ground wire on the **LEFT HAND** side of the wall stud.

# INSTALLATION INSTRUCTIONS (Continued)

## Mounting the Master

Remove the master cover from the base by carefully inserting a screwdriver into either slot in the lower left or right hand side of the master panel and gently popping off cover. Set master cover aside for later installation.

Remove the warranty registration card and mounting screw packet from back of base unit. Set both items aside.

Locate the two U-shaped slots at the top of the base. Position master base onto wall, and route all cables through the U-shaped slots. Keep in mind the master panel cover must conceal all previously drilled wiring holes and cables.

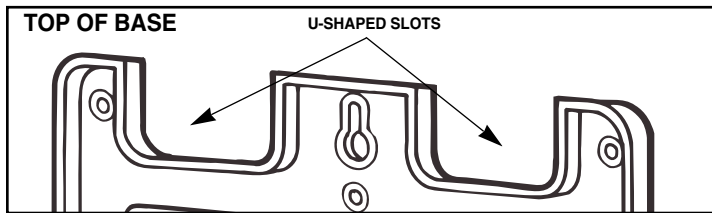
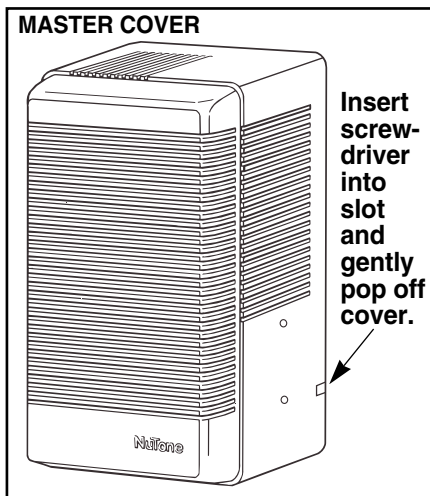

Using a pencil, mark on the drywall the upper and lower mounting keyhole slots in the base. The marks must be aligned over the wall stud to securely hold the unit.

Set the master base unit aside. Drill the two marked holes using a 1/8" drill bit. Drill to a depth of 1 1/4". Insert the two mounting screws (supplied) until 3/8" of the screws are protruding from the drywall.

Position the master base over the mounting screws. Slide base downward until the screws reach the top of the keyhole slots. Tighten and secure the screws.

## Connecting the IW-6 Remote Station Wiring at the Master

Position the IW-6 remote station cables in the U-shaped slots. Strip back the outer insulation from each IW-6 cable.

Using a piece of tape or wire tie, bind the cables together.

Separate the cables into color groups. See Fig. A.

Strip 3/8" of insulation from each strand of cable.

See Fig. B.

Using pliers, twist the bare end of each colored set together. See Fig. C.

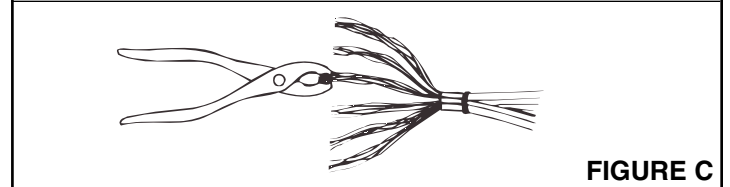
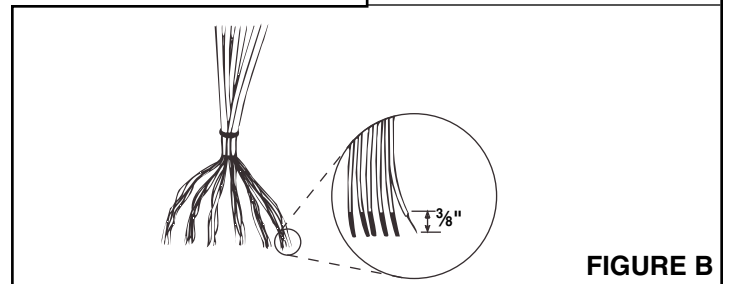
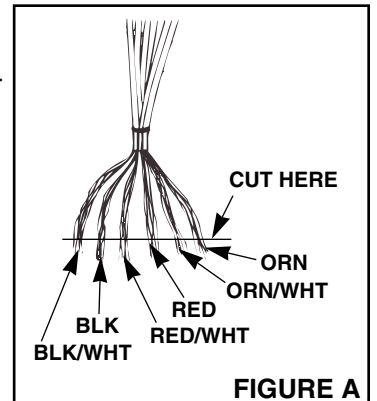

After grouping colored wiring together, connect each group to the matching screw terminal in the 6 screw terminal block.

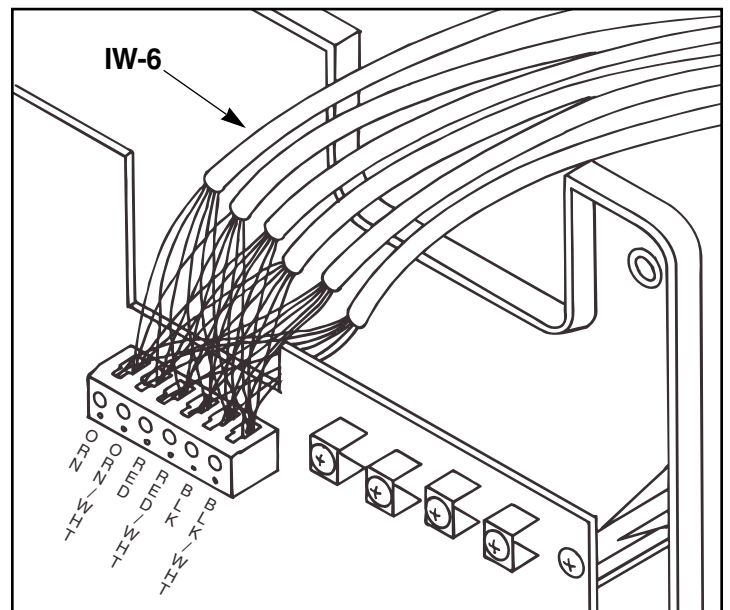

# INSTALLATION INSTRUCTIONS (Continued)

## Connecting the Door Speakers at the Master

To connect the door speaker cable, strip back 5/8" of the IW-2 cable and wrap each wire around the screw terminals marked "Door Speaker". A maximum of three door speakers can be connected to these screw terminals.

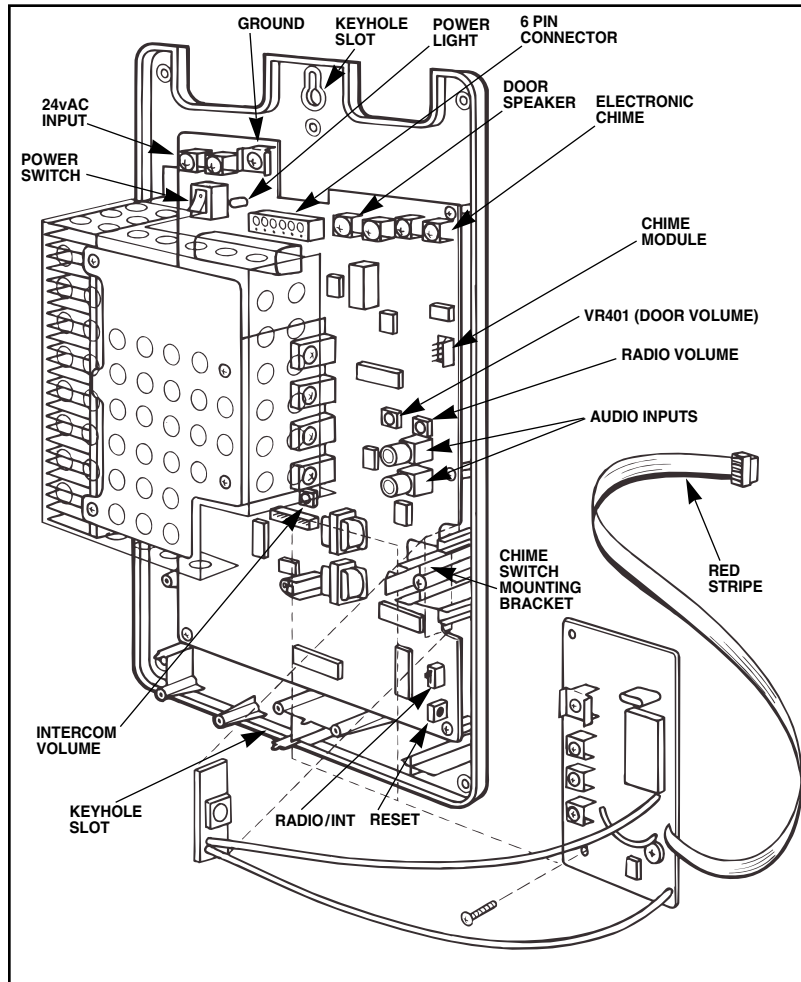

chime module marked "PB Common" and "Front" when connecting the front door pushbutton. To connect the rear pushbutton, use the "PB Common" and "Rear" terminals. Use "PB Common" and "Side" for side door pushbutton connection.

Chime module package contains additional installation instructions.

## Additional IA-29 Mounting Instructions

Locate the chime selector switch mounting bracket on the base of the master.

Remove and set aside the retaining screw on the base of the the master unit.

Remove and discard the square foam pads on the chime selector switch PC board connected to the chime module.

Slide the PC board into the mounting bracket on the master.

Fasten the chime selector switch PC board with the retainer screw previously removed from base.

## Connecting an Optional Electronic Chime

Strip back 5/8" of NuTone IW-2 wire from the optional electronic chime. Connect wires to the screw terminals marked "Electronic Chime" on the master.

Electronic chime package contains additional installation instructions.

## Connecting an Auxiliary Audio Source

Connect a phono type plug to the left and right shielded audio cables from the music source. Follow the phono plug manufacturer's instructions when connecting the cable.

Plug the left and right cables into the "Audio Input" jacks on the master. The left and right input jacks are interchangeable.

NOTE: If the music source is monaural the shielded audio cable and plug can be connected to either jack. (Do not plug more than one music source into the IM-5000).

## Connecting an Earth Ground

**CAUTION – PROPERLY EARTH GROUNDING THE IM-5000 IS REQUIRED.**

Connect the 14 gauge copper ground wire to the screw terminal at the master marked "Ground".

**CAUTION: Avoid touching the ground wire to any other components on the circuit board of the master unit.**

## Connecting an Optional Electronic Chime Module (IA-28 or IA-29)

Mount the chime module to the lower right hand corner of the master unit base.

Fasten the chime module to the base using the screw supplied with the module.

Carefully plug the 4-pin connector of the chime module into the mating connector at the master marked "Chime Module". Position the cabled side of the connector closest to the heat sink when plugging into 4 pin connector. The red stripe on the ribbon cable is positioned towards the bottom of the unit.

**Caution: Improper connection of the chime module will cause damage to the master unit and chime module.**

Strip back 5/8" of NuTone S-143 chime pushbutton wire. Position and connect the S-143 to the screw terminals on the



# INSTALLATION INSTRUCTIONS (Continued)

## Connecting the 24 Volt AC Transformer wires

Make sure AC power to the 401T transformer and the Power toggle switch at the master is OFF.

Strip back 5/8" of the NuTone S-143 cable. Connect the cable from the 401T 24 volt transformer to the screw terminals on the master base marked "24 VAC input".

**CAUTION: Avoid touching the transformer wires to any other components on the circuit board of the master unit.**

## Checking all the Connections at the Master

The wiring to the IM-5000 Selective Call intercom is now complete. Take a moment to check (✓) all connections.

- Check color coding on the IW-6 wiring from the remote stations.
- Check all screw terminal connections.
- Check clearance around all screw terminals and wire connections; make sure wires are only touching screw terminals and no other components.
- Check connections at remote stations, door speakers, pushbuttons, chime, auxiliary audio source, earth ground and 401T transformer.
- Check master unit power switch is OFF.

## Setting the Remote Station Switches

**IMPORTANT: The Remote Stations must be set as stations 02 through 21.**

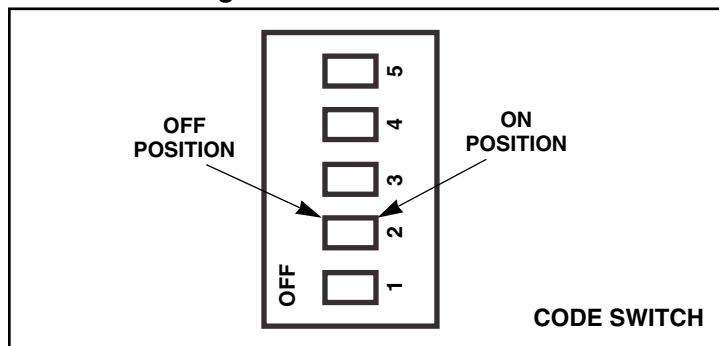

Locate the Code Switch on the back of the remote station. Determine the station identification number.

Study the following chart.

If the Remote station is to be Station number:	These numbers on the code switch must be in the ON position.
02	2
03	1 & 2
04	3
05	1 & 3
06	2 & 3
07	1, 2, & 3
08	4
09	1 & 4
10	2 & 4
11	1, 2, & 4
12	3 & 4
13	1, 3 & 4
14	2, 3, & 4
15	1, 2, 3, & 4
16	5
17	1 & 5
18	2 & 5
19	1, 2, & 5
20	3 & 5
21	1, 3, & 5

Set the code switches to the determined station identification numbers for each remote station.

## Powering Up the System

**REMINDER: Do not apply power until you have checked all connections and set station identifications.**

1. Turn on circuit breaker that powers the 401T transformer.
2. Measure the AC voltage from the transformer at the AC terminals on the master. The voltage should measure 22 to 30 volts AC.
3. Press the "Power" switch on the master unit to the ON position to apply power. The red power LED will illuminate once power is applied.

# OPERATIONAL CHECKOUT

## General Intercom Operation

---

**NOTE:** Refer to the homeowner's manual for complete information on intercom operation.

When an intercom call is initiated, a **CALL TONE** will be heard at the station from which the call is placed and the station that is being called.

**NOTE:** The **CALL TONE** will not be heard at Door Speaker locations.

The station that is being called is answered "hands-free" without pressing a key.

The intercom volume is adjusted by using the **INTERCOM VOLUME** control and may only be adjusted during an intercom call. The music volume is adjusted using the **RADIO (MUSIC) VOLUME** control.

When an intercom call is in progress, the **BUSY** light will be on at stations not participating in the call. An intercom call cannot be made from a station when the busy light is on.

## Setting the Intercom Audio Level

---

In most installations, the "Intercom Volume" trimpot in the master will not require adjustment. However, follow these steps if an adjustment becomes necessary.

Call one remote station from another. Set the **INTERCOM VOLUME** control at the receiving station to the maximum level. **NOTE:** The intercom volume may only be adjusted when the system is in the intercom mode.

If further adjustment is necessary, use a small thin-blade screwdriver to adjust the "Intercom Volume" trimpot on the Master P.C. Board.

The **INTERCOM VOLUME** control at all remote stations may now be adjusted to the desired level with no further adjustment to the Intercom Volume trimpot.

## Setting the Auxiliary Audio Level

---

Set the **RADIO (MUSIC) VOLUME** control to the maximum level at the remote station located closest to the master station.

Set the Radio (Music) Volume to the **OFF** position at the other remote stations.

Turn **ON** the auxiliary audio source connected to the master.

Using a small thin-blade screwdriver, adjust the "Radio Volume" audio trimpot in the master until the audio at the remote station is at the desired level. **NOTE:** If the auxiliary audio is increased to a high level, the music volume may be too loud at the lowest setting at the remote stations.

The **RADIO (MUSIC) VOLUME** control at all remote stations may now be adjusted to the desired level with no further adjustment to the "Radio Volume" trimpot in the master.

## Setting the Door Speaker Volume Level

---

In most installations, the Door Speaker volume will not require adjustment. However, follow these steps if an adjustment is necessary.

1. Locate the door speaker volume trimpot labeled "VR401" on the master station's P.C. Board.
2. Call a door speaker from a remote station. Press **TALK** and speak in a normal voice.
3. Adjust the VR401 trimpot until the desired door speaker volume level is achieved. **NOTE:** This setting controls the audio level to the door speaker only.

## Selecting the Chime Module Audio Mode

---

The chime module audio may be selected to be controlled from the **RADIO (MUSIC) VOLUME** control or the **INTERCOM VOLUME** control. The NuTone IM-5000 Selective Call Intercom chime module audio is factory preset to be distributed through the **RADIO (MUSIC) VOLUME** Control.

Use the following directions to select the desired mode.

### Chime Module Audio heard over the Radio (Music) Volume Control

Position the Chime mode selection switch marked "Radio/Int" on the master P.C. board to **RADIO**.

When the chime module sounds, the audio from the chime can be adjusted using the **RADIO (MUSIC) VOLUME** at the remote stations.

### Chime Module heard over the Intercom Volume Control

Position the chime mode selection switch marked "Radio/Int" on the master P.C. board to **INT**.

When the pushbutton is pressed, a **CALL TONE** will be heard followed by the chime sound.

When the chime module sounds, the audio from the chime can be adjusted using the **INTERCOM VOLUME** at the remote stations.



# OPERATIONAL CHECKOUT (Continued)

## Placing the Master Cover Over the Master Base

Position the top of the cover onto the top of the base.

When the cover and base are aligned, press on the front cover until the cover snaps over the base.

## Resetting the Microprocessor

If the intercom system does not operate properly, the internal microprocessor may require resetting. There are three (3) levels of resetting that have been incorporated into the intercom system.

1. **To reset a remote station**, press \*9# on the station's keypad. This will reset the microprocessor in that particular remote station only.
2. **To reset the master**, locate the lowest hole on the right hand side of the panel directly in front of the panel slot. Using a pencil or pen point, press the reset switch through the hole.
3. **To reset the complete system**, remove the cover from the base of the master unit. Locate the **POWER** switch in the upper left corner of the master and toggle to the **OFF** position. Wait 30 seconds. Return the power switch to the **ON** position.

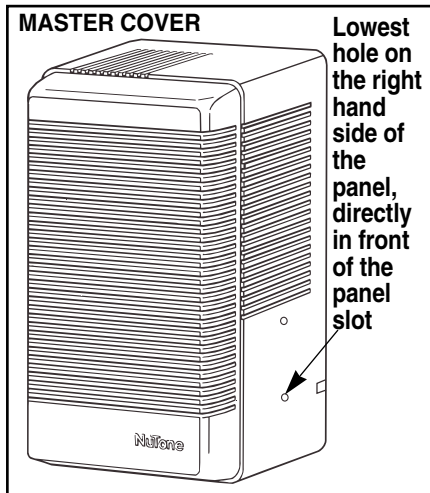

## Completing the Installation

Check (√) all items below for final system check.

- Master unit is properly aligned and securely installed.
- All connections at the master are correct.
- All screw terminals have proper clearance.
- Remote station identifications are set.
- Optional chime/pushbuttons are properly connected and functioning.
- All volume controls are satisfactory.
- Master unit is properly earth grounded.
- Power has been applied at the circuit breaker and at the master.
- Station identifications are documented for the homeowner and are in hand.
- Warranty card is in hand.
- Homeowner's instructions are in hand.
- Installation Instructions are in hand.
- The above four (4) items are grouped together for transfer to the homeowner.
- Items delivered. Installation complete.

## Tone Generator Volume Adjustment

The tone generator creates the tones that are heard from each station (call tone, error tone, feedback tone).

A trimpot is located at each remote station to allow custom level adjustment.

To adjust the level at a particular station:

1. Enter an invalid keypad entry: Example: 3
2. Locate the ringer trimpot access hole next to the black wire connection terminal.
3. Adjust the trimpot to the desired level using a small screwdriver.

# INSTALLER'S TROUBLESHOOTING GUIDE

TROUBLE	POSSIBLE CAUSE	POSSIBLE REMEDY
Hum in remote stations.	The intercom wiring has been run too close to the household AC power wiring.	Be certain the intercom wiring is as far away as practical from the household AC power wiring. Do not run the intercom wiring parallel to the AC power wiring.
	Wire installation.	Check the ORN, ORN/WHT, RED, RED/WHT wires for shorts or opens at the master and at each remote station.
	Interference from household electrical fixtures.	A dimmer or fluorescent light may cause interference. Filters should be used for dimmer or fluorescent light interference (G.E. 89G635 or equivalent - purchase locally.)
	Power transformer is located too close to the master.	Relocate power transformer.
A selective intercom call cannot be made.	Wire installation.	Check BLK, BLK/WHT (serial data) wires to be certain they are properly connected to master and each remote station.
	Improper setting of remote station code switch*.	Check to make sure the station code has been set at all stations and no two stations have the same station code.
No intercom or music from the remote stations.	Power switch in the master is in the off position.	Switch the power to the on position, power LED is lit.
	Improper wiring installation at the master.	Check the wiring going to the remote station connector at the master.
	No electrical power to the remote stations.	Be certain 120vAC, 60Hz power has been provided to the primary of the 401T transformer. No less than 22vAC should be measured on the secondary of the transformer.
	Defective transformer.	Replace transformer.
No door communication.	Wire installation.	Check the wires at door speakers and at the master's door terminals.
		Check BLK, BLK/WHT (serial data) wires to be certain they are properly connected to the master and each remote station.
	Speaker.	Check the continuity of the door speaker.
	Incorrect door speaker volume setting.	Follow "Setting the Door Speaker Volume Level" instructions in this booklet. Note: This setting effects only the audio going to the door speaker.
The music volume is too loud when the remote stations are set on the first volume step.	Improper setting of the Radio Volume trimpot at the master.	Decrease the radio audio level by turning the "Radio Volume" trimpot (counter clockwise) until the desired audio level has been achieved with the remote stations set in their first volume step (refer to "Setting the AUX Audio Level").
The music volume is distorted regardless of the setting of the remote station volume control.	Audio source's signal is too large.	Decrease the radio audio level by turning the "Radio Volume" trimpot (located on the master station's PC board) counter clockwise until the audio becomes undistorted with "Radio"(Music) volume control at the remote stations adjusted to maximum.

# INSTALLER'S TROUBLESHOOTING GUIDE

TROUBLE	POSSIBLE CAUSE	POSSIBLE REMEDY
The system squeals when the intercom is being used.	The station in the adjacent room(s) is mounted on a common wall (back to back).	If the remote stations have been mounted back to back, one of them will have to be relocated. If the stations are on a common wall, place fiberglass insulation behind each station or isolate the station from the wall by placing rubber washers or weather stripping between the station and the wall surface.
Static.	Loose ground connection.	Check the ground connection to the master and the connection to earth ground.
	Interference from household electrical fixture.	A dimmer or fluorescent light may cause interference. For dimmer or fluorescent light interference, use filters (G.E. 89G635 or equivalent, purchase locally).
	Interference from household electrical appliances.	Correct interference at the source: fishtank heater, hand tools, coffee pot, etc.
	Wire installation.	Check all wiring in the system: Remote stations, chime, and transformer connections at the master and connections at remote stations.
Optional Electronic Chime Module (IA-28 or IA-29) does not operate or operates at a low level.	Wire installation.	Be certain the chime is properly connected to the master. Also, be certain the front, side and rear buttons are properly connected to the chime board.
	Improper volume setting.	Adjust the volume of the chime module by turning the volume potentiometer located on the chime module behind the 4-pin ribbon cable connector.
	Wire installation.	Check the door terminals on the chime module by shorting the common terminal to each of the door terminals front, rear and side. The chime should play.
Electronic chime can't be heard through the remote stations.	Wire installation.	Be certain the electronic chime is properly connected to the master electronic chime input screw terminals.
	Improper volume setting.	Adjust the I-COM trimpot located on the electronic chime.
Call tone volume at a Remote station is too loud.	Improper volume setting.	Use the *1# control function to adjust volume. Refer to "Station Call Tone Volume" in the homeowner's instructions.

**\*IMPORTANT: Be certain the system has been disconnected at the main power source prior to setting the code switches. Powering the system up will allow the station identification to be effective.**

Product specifications subject to change without notice.

**NuTone**<sup>®</sup>

4820 Red Bank Road, Cincinnati, Ohio 45227  
Printed in China, Rev. 4/02, Part No. 86024