

## Indoor Remote Controls

### MODELS: IC-201, IC-301

For use with IM-2003 Series, IM-3003 Series and IM-3103 Series Radio-Intercom Systems to operate the ISA-78 speaker.

**IMPORTANT:** Speakers that do not have built-in controls require a separate remote control.

Models IC-201 and IC-301 are designed for **INDOOR** use only. Use Models IC-201W and IC-301W for outdoor installation.

### ROUGH-IN FRAME MOUNTING

1. The remote controls may be recess-mounted to the Model IR-81 Rough-In Frame.
  2. The remote controls may be surface-mounted to the Model IA-81 remote control frame.
  3. The mounting frame and wiring should be installed when the system is roughed-in.
  4. The remote controls require NuTone IWA-3, 3-conductor, flat ribbon cable from the master station to the remote control location. NuTone IW-2, 2-conductor, twisted pair (22/2) cable from the remote control to the speaker.
- See instructions packaged with the mounting frames.

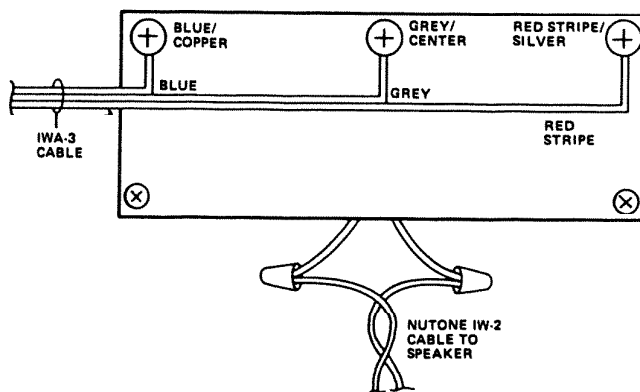

FIGURE 1

### WIRING CONNECTIONS

1. Connect color-coded wires (IWA-3 cable) from master unit to the matching terminal screws on the remote control's printed circuit board as follows: red-stripe wire to terminal marked RED-STRIFE; grey wire to terminal marked GREY/CENTER; blue wire to terminal marked BLUE/COPPER. See Figure 1.
2. If push-on terminals are attached to the ends of the remote control's speaker wires, cut off terminals and strip wires to make wiring connections to the speaker. See Figure 1.
3. Connect IW-2 cable from the speaker to the remote control's two speaker wires. See Figure 1.

### WIRE MATCHING CHART

NuTone has adopted the use a new 3-wire color-coded cable. If you are replacing an older model Radio-Intercom, use this chart to match the "copper/center/silver" designations of older wiring with the blue/grey/red-stripe color-coded wire.

| OLD CABLE | NEW CABLE  |        |
|-----------|------------|--------|
|           | Insulation | Wire   |
| Copper    | Blue       | Copper |
| Center    | Grey       | Center |
| Silver    | Red Stripe | Silver |

**MOUNTING**

1. Carefully place excess wire behind IR-81 frame or into IA-81 frame.
2. **Recess Mounting** — When finished wall is in place, secure remote control panel to frame with two (2) mounting screws (furnished). See Figure 2.
3. **Surface-Mounting** — Place edge of remote control into the groove of IA-81 surface-mount frame. Make sure the remote control panel and the frame fit together tightly. Secure remote control panel to frame with two (2) mounting screws (supplied with IA-81 surface mounting frame). See Figure 3.

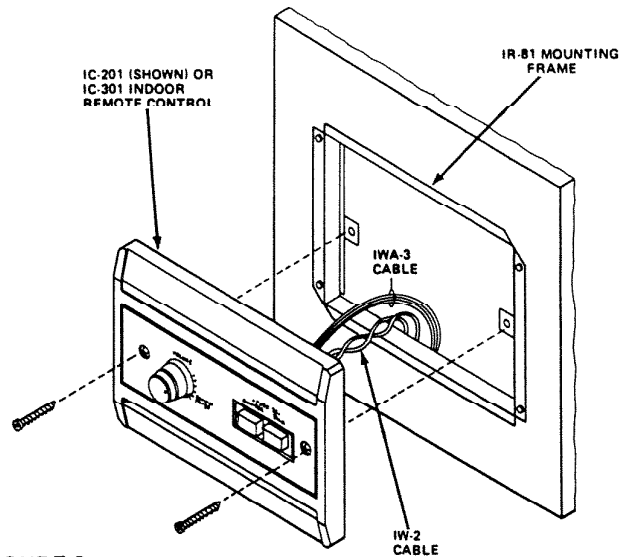

**FIGURE 2  
RECESS MOUNTING**

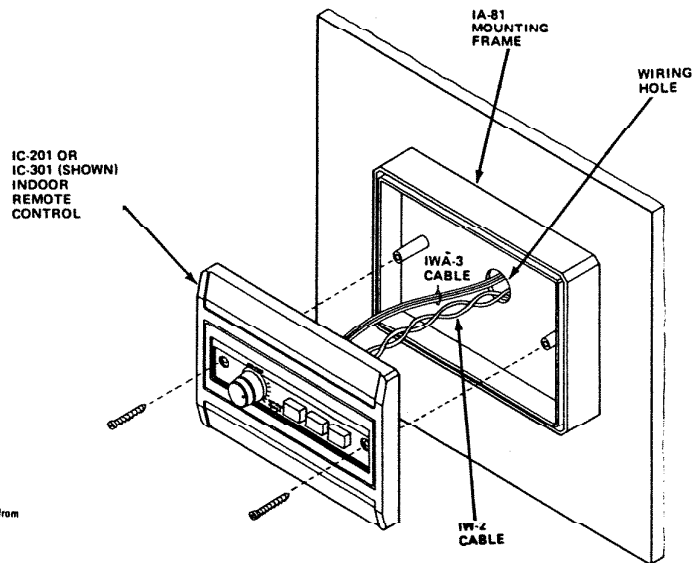

**FIGURE 3  
SURFACE MOUNTING**

**Limited Warranty**

NuTone products are warranted to be free from defects in material and workmanship for the "Warranty Period" which is (a) ten years from date of original manufacture in the case of Motors employed in all NuTone Paddle Fans; and (b) twelve months from date of original installation in the case of all other NuTone products. Light bulbs, dial lights, record changer needles, batteries (with the exception of those specifically designated as rechargeable) and other consumable items, are not warranted or guaranteed in any manner for any length of time.

Our warranty does not cover damage or failure caused by Acts of God, abuse, misuse, abnormal usage, faulty installation, improper maintenance or any repairs other than those provided by a NuTone Authorized Service Center. There are no obligations or liabilities on the part of NuTone or Scovill Inc. for consequential damages arising out of or in connection with the use or performance of the product or other indirect damages with respect to loss of property, revenues or profit, or costs of removal, installation or reinstallation. All implied warranties, including implied warranties for merchantability and implied warranties for fitness, are limited in duration to: (a) ten (10) years from date of original manufacture in the case of Motors employed in all NuTone Paddle Fans; and (b) twelve (12) months from date of original installation in the case of all other NuTone products.

Some states do not allow the exclusion or limitation of incidental or consequential damages and some states do not allow limitations on how long an implied warranty lasts, so the above exclusions or limitations may not apply to you.

During the "Warranty Period", NuTone will repair or replace, at NuTone's sole option, free of charge, any defective parts returned prepaid to our closest NuTone Authorized Service Center, provided, however, NuTone will not be responsible for and will not pay for any costs or expenses relative to removal or reinstallation of any product or any part of any product after the first 12 months of the "Warranty Period" have expired. Please provide the model number of the product, original date of installation and nature of difficulty being experienced. There will be charges rendered for product repairs made after our "Warranty Period" (as defined above) has expired. This warranty gives you specific legal rights and you may have other rights which vary from state to state.

For the name of your nearest NuTone Authorized Service Center, residents of the contiguous United States should call, Toll Free, 1-800-543-8887.

Residents of Alaska, Hawaii and other locations outside the contiguous United States should write to NuTone Division, Scovill Inc., Madison and Red Bank Roads, Cincinnati, Ohio 45227 - Attention: Department of Consumer Relations. Rev. 2-84

Product specifications subject to change without notice.

**NuTone**

Housing Group **Scovill**

Madison and Red Bank Roads, Cincinnati, Ohio 45227  
Printed in U.S.A. Rev. 1/85, Part No. 49269