



INSTALLATION INSTRUCTIONS

EXPANSION MODULE

MODEL: IAA-440

FOR USE WITH IMA-4406 MASTER STATION

This booklet contains information for installing the IAA-440 expansion module into the IMA-4406 master station. All system wiring and rough-in frames should be installed before mounting and wiring the expansion module and master station.

Refer to the installation instructions packaged with the master station and rough-in frames for detailed wiring information. For more detailed information on wiring and mounting other system components (i.e., speaker, remote control, etc.), refer to the installation instructions packaged with each separate component.

TABLE OF CONTENTS

INSTALLATION	PAGE
Contents of Carton1
Precautions and Guidelines1
Wiring Specifications2
Remote Station Wiring2
Maximum Number of Remote Stations2
Mounting the Terminal Board2
Connecting the Expansion Terminal to the Master Station Terminal Board3
Connecting the Remote Wiring3
Connecting Volume Control Wiring4
Applying the Switch Inlay4
Mounting the Switch Circuit Board5
Connecting the Expansion Switch Board to the Expansion Terminal Board5-6
WARRANTY8

CONTENTS OF CARTON

Check (✓) for the following IAA-440 carton contents.

- IAA-440 switch circuit board
- Terminal board
- Hardware bag assembly containing:
 - 4 - N° 6 x 3/8" screws
 - 2 - magnets
- Switch cover inlay
- Installation instructions
- Product Registration Warranty Card

NOTE TO INSTALLER: Do not discard these installation instructions. Please give installation instructions, and warranty registration to homeowner.

PRECAUTIONS AND GUIDELINES

The NuTone IAA-440 expansion module has been designed for ease of installation. Please read and follow ALL installation instructions, guidelines and precautions. Any deviation from these instructions or miswiring combinations may result in unit failure and void of warranty.

WARNING!
120 Volt AC Power to Transformers in the IR-105 Rough-in MUST Remain OFF until ALL System Wiring at the Master and Remote Stations is Complete.

- Observe all local building regulatory codes in your area.
- All screw terminals at the master and remote stations must be secure.
- Observe all color code connections of wires when connecting the remote stations to the master.
- The IMA-4406 and IAA-440 are designed to be installed with only NuTone specified wire. No other wire should be used. The use of wire other than NuTone wire will void all NuTone warranties and may result in faulty installation and improper operation.

IMPORTANT WARNING!
THE POWER TRANSFORMER CONTAINS AN INTERNAL FUSE.
DO NOT SHORT THE LOW VOLTAGE CONNECTING SCREWS OF THE TRANSFORMER OR THE TRANSFORMER WILL BE DESTROYED!

INSTALLATION

WIRING SPECIFICATIONS

See the IR-105 master rough-in frame installation instructions for detailed wiring information.

Use NuTone IW-6, 3 twisted pair for connecting:

- Remote controls to master
- Remote stations to master

Use NuTone IW-2, 22 ga. twisted pair for connecting:

- Remote controls to speakers
- Speaker volume control (IC901) to master
- Speaker volume control (IC901) to speakers

REMOTE STATION WIRING

An individual 6-wire cable (IW-6) must be connected from each remote station or remote control location to the master station and expansion module terminal boards.

Maximum station wire length: 750 ft.

Maximum total length of IW-6 cable per system: 4,000 ft.

IMPORTANT! NuTone cannot be responsible for improper system operation that results from interference generated by light dimmers, fluorescent lighting fixtures, and similar electrical products. Such interference must be corrected at the source. TO HELP REDUCE THIS INTERFERENCE, ALL WIRING CONNECTIONS TO THE MASTER MUST BE PLACED AT LEAST 12 INCHES FROM ANY AC POWER WIRING. AVOID RUNNING INTERCOM WIRES PARALLEL TO AC POWER WIRING.

MAXIMUM NUMBER OF REMOTE STATIONS

The expansion module will accommodate up to 6 additional connections from any combination of remote stations, remote controls and/or speaker volume controls.

NOTE: NEVER CONNECT MORE THAN ONE REMOTE STATION TO A SET OF SCREW TERMINALS.

WARNING! NEVER EXCEED A TOTAL OF 15 NUTONE 25 OHM SPEAKERS ON THIS SYSTEM.

WARNING! NEVER USE STANDARD 8 OHM STEREO SPEAKERS ON THIS SYSTEM. USE ONLY NUTONE SPECIFIED SPEAKERS ON THIS MASTER.

MOUNTING THE TERMINAL BOARD

NOTE: If you are currently installing the IMA-4406, complete the installation of the master through the section titled “Mounting the Optional Chime Module in the Master Station Panel” in the IMA-4406 Installation Instructions.

Continue your installation following these instructions:

1. Remove and clean any drywall debris or dust from the rough-in before beginning installation.
2. **Refer to Figure 1.** Locate the terminal board in the right rear section of the rough-in frame.
3. Use four (4) N° 6 x 3/8" screws supplied to secure the terminal board to the rough-in frame.
4. Make certain the lower left-hand screw is secure and snug against the ground lug which covers the mounting hole in the terminal board. Do not bend ground lug. Make sure it is positioned between the screw and terminal board.

▶ IMPORTANT ◀

DO NOT APPLY POWER TO THE SYSTEM UNTIL ALL CONNECTIONS ARE COMPLETE AT THE MASTER, EXPANSION MODULE AND REMOTE STATIONS.

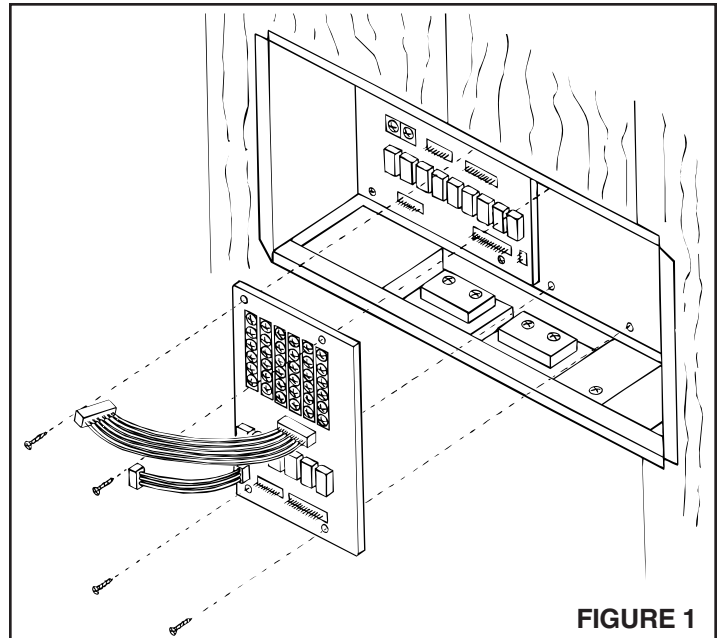
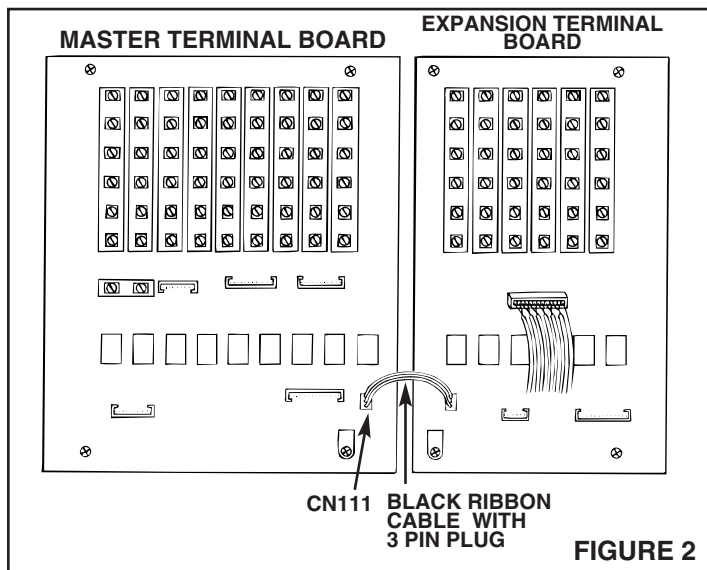

FIGURE 1

INSTALLATION (Continued)

CONNECTING THE EXPANSION TERMINAL BOARD TO THE MASTER STATION TERMINAL BOARD

1. Refer to Figure 2. Insert the black ribbon cable with three (3) pin plug into the master station terminal board connector CN111.
2. Additional connections will be made after the master station panel has been mounted to the rough-in frame.



Only connect **one** remote to each set of screw terminals. After completing all connections, check for any shorted wires. Dress cables flat against the terminal board to allow space for the master station to be properly secured.

3. Refer to installation instructions packaged with the remote stations and remote controls for wiring these units.
4. Refer to Figure 4. Use the Wire Matching Chart if you are retro-fitting a system with the previously used IW-6R cable.

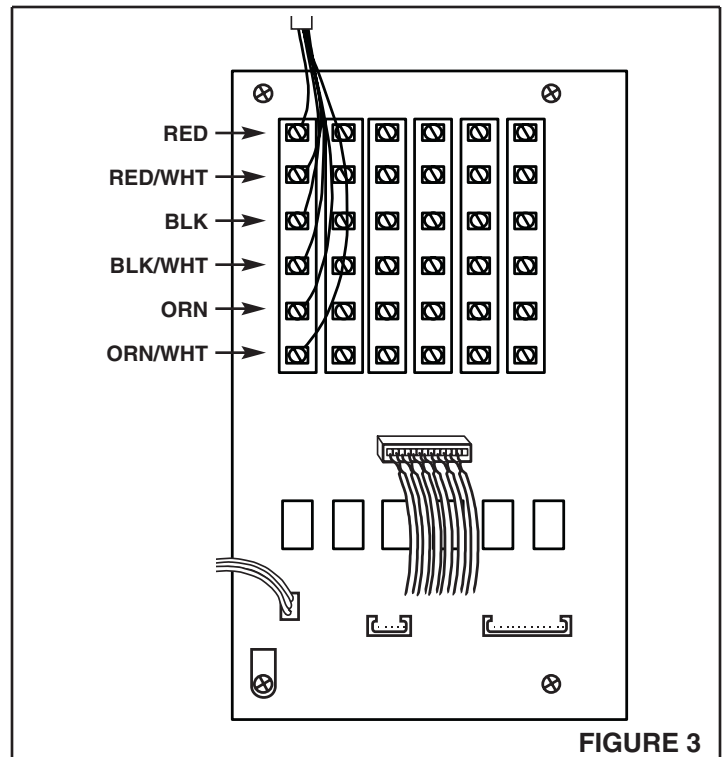

CONNECTING THE REMOTE WIRING

► IMPORTANT ◀

All Remote Stations, Remote Controls, and Speaker Volume Control Wiring **MUST** Return Directly to the Expansion Module Terminal Board. **DO NOT** CONNECT WIRING FROM SPEAKER TO SPEAKER!

1. Dress all remote wiring through the rectangular holes in the upper right and left sides of the rough-in frame. All wiring connections are made to the expansion module terminal board.
2. Refer to Figure 3. Connect the IW-6 cable from each remote to the appropriate set of terminal screws at the expansion module terminal board. When connecting the cable to the terminal board, be sure to observe the matching of all color codes.

Connect: RED to RED
 RED/WHT to RED/WHT
 BLK to BLK
 BLK/WHT to BLK/WHT
 ORN to ORN
 ORN/WHT to ORN/WHT

IMPORTANT – WHEN NUTONE MODEL IW-6R WIRING IS USED:

CONNECT TO THE SCREW TERMINALS ON THE TERMINAL BOARD MARKED:

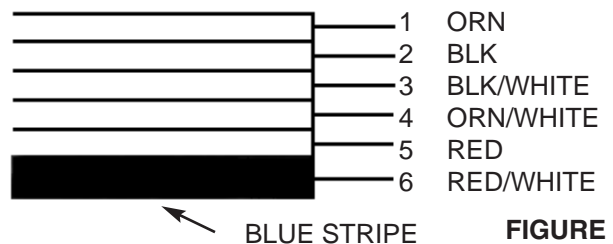

INSTALLATION (Continued)

CONNECTING VOLUME CONTROL WIRING

Refer to Figure 5. If a NuTone Volume Control is installed in the system, connect the control's IW-2 wiring to the ORN and ORN/WHT screw terminals at the master station. **Only ONE NuTone speaker may be connected to each volume control. Each volume control/speaker counts as a remote station. Remember: The maximum remote connections to the Master Station is 9. Adding the optional IAA-440 expansion module will increase the system remote capability to 15 stations.**

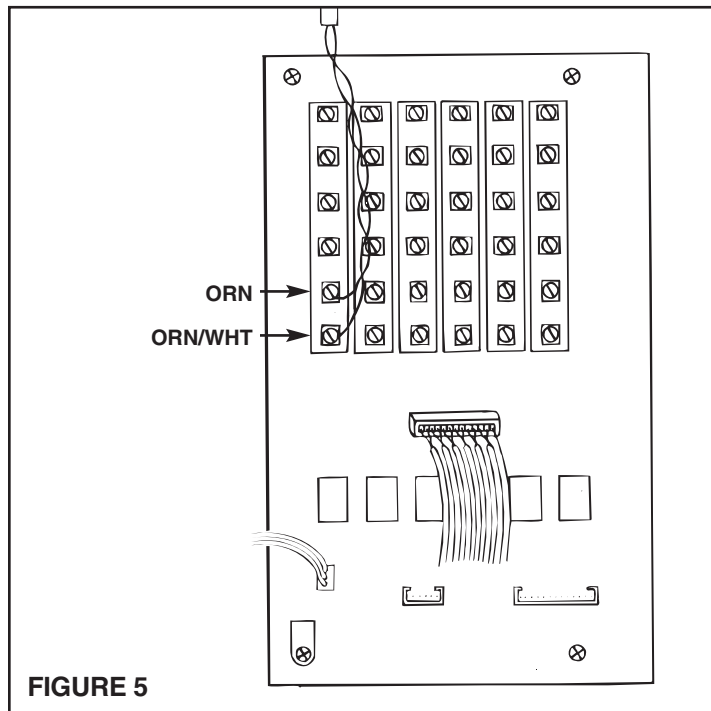

FIGURE 5

NEVER USE 8 OHM STEREO SPEAKERS WITH THIS SYSTEM!

Refer to the installation instructions packed with the speaker volume control for wiring this unit.

APPLYING THE SWITCH INLAY

Installing the black adhesive switch inlay will require working from both the front and rear of the master station panel. When working from the rear of the panel, position the master station panel on a soft cloth to prevent surface damage.

1. Remove the lower right side door from the master station by first opening the door and then pushing it in a downward motion to snap it free from the master station panel. Set door aside for later installation.
2. Refer to Figure 6. From the rear of the master station panel, use a straight-blade screwdriver and apply pressure on the back of the inlay panel at the last switch location. Continue applying pressure until the end of the inlay separates from the panel.
3. Grasp and carefully peel free the inlay from the front of the panel.

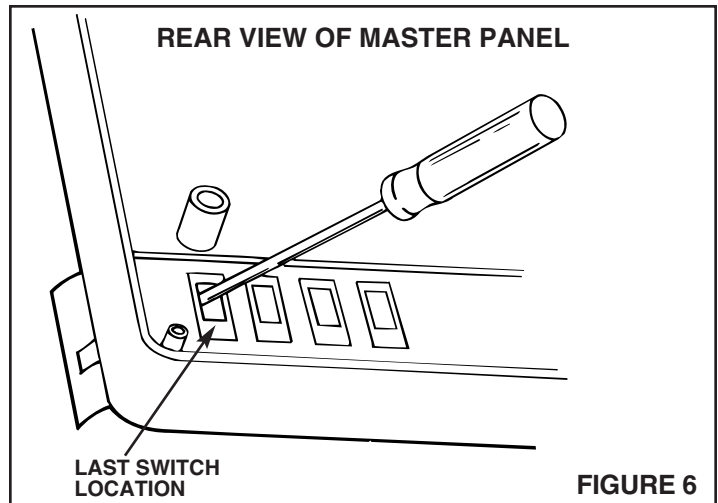

4. Refer to Figure 7. Determine if the two (2) magnets are located in each magnet pocket in the panel after removing the inlay. For installer convenience, NuTone has added two (2) magnets in the hardware bag should the original magnets become misplaced. If a magnet is missing, install a spare magnet by first positioning and then pressing it in place.

NOTE: Be sure the magnets are in place before applying the new switch inlay.

5. Once the magnets are secure, remove the adhesive tape from the back of the new switch inlay.
6. Apply the new switch inlay over the expansion module switch area where the original inlay was removed.
7. Remove the protective film covering the front on the inlay.
8. Replace the lower door onto the front panel by simply snapping it into place.

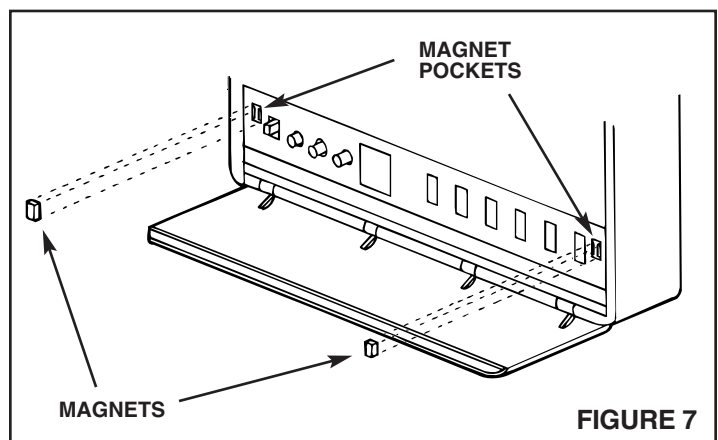

INSTALLATION (Continued)

MOUNTING THE SWITCH BOARD

To install the switch circuit board, first position the master panel face down onto a soft cloth to prevent surface damage.

1. **Refer to Figure 8.** Remove five (5) N° 5 x 5/16" from master panel. Set screws aside for later installation.
2. **Refer to Figure 9.** Plug black ribbon cable with 7 pin plug from master into CN1101 of switch circuit board. Be sure alignment keys face front of master panel.
3. **Refer to Figure 10.** Position ribbon cables as shown and position board into panel.
4. Fasten the switch board to the master station panel with five (5) N° 5 x 5/16" previously removed screws.
5. Refer to the "**Mounting the Master Station**" section of the IM-4406 installation manual.

CONNECTING THE EXPANSION SWITCH BOARD TO THE EXPANSION TERMINAL BOARD

After connecting the master station to the terminal board, as indicated in the IMA-4406 installation instructions ("**Connecting the Master Station to the Terminal Board**"), continue with the connection of the expansion switch board to the expansion terminal board.

There are two (2) connections that must be made between the expansion terminal board and the expansion switch circuit board. Additionally, one connection must be made from the expansion terminal to the master station.

When making the following connections, make sure the alignment keys in the connectors are properly aligned before applying pressure to the connectors.

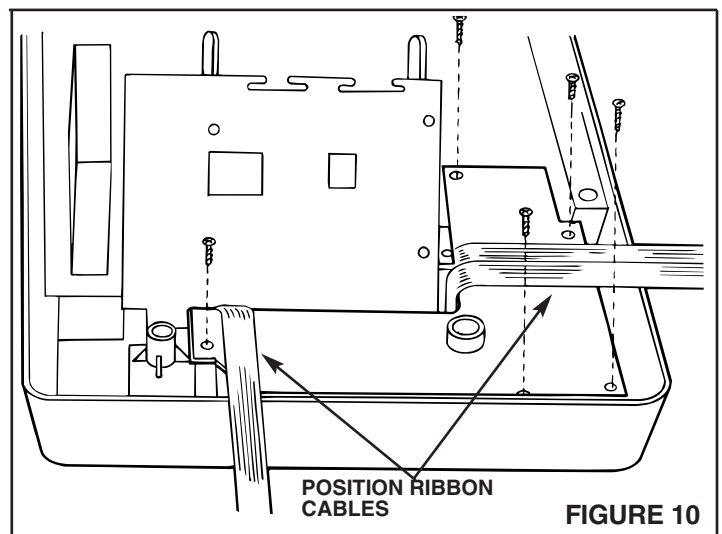
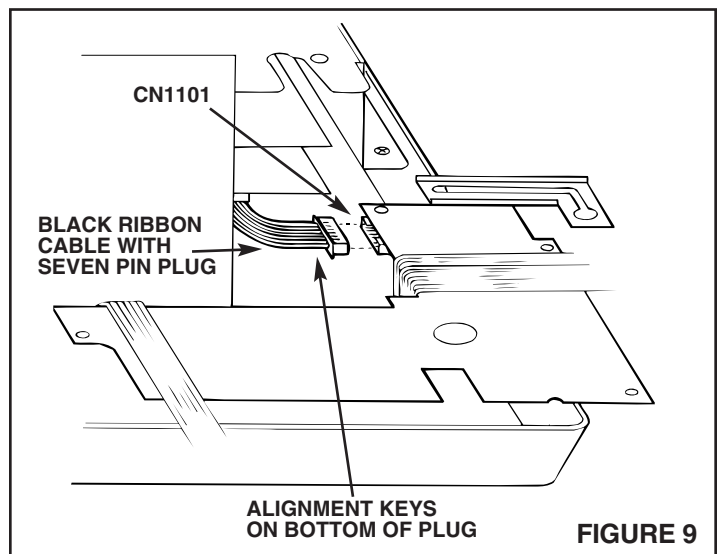
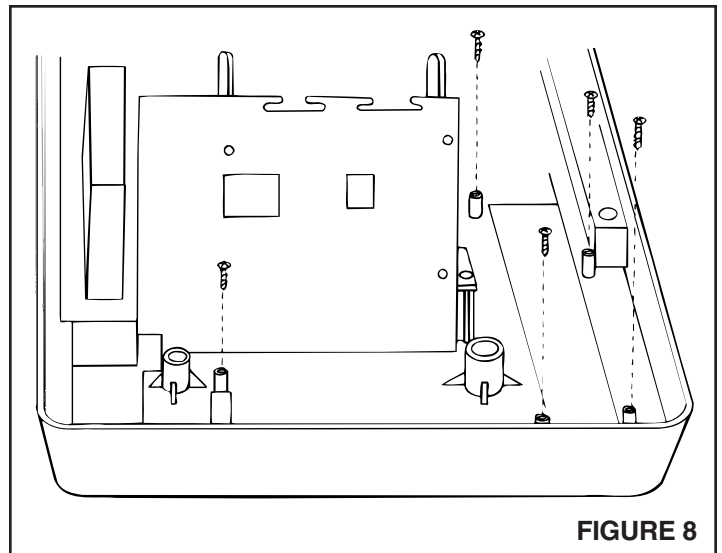

INSTALLATION (Continued)

1. Refer to Figures 11 and 12. Insert the gray shielded cable with 13 pin plug from the expansion terminal board into CN411 connector on master station.
2. Refer to Figures 12 and 13. Insert the black ribbon cable with the 13 pin plug from the expansion switch board into CN1201 connector on the expansion terminal board.
3. Insert the multi-color ribbon cable with the 6 pin plug from the expansion switch board on CN1206 connector on the expansion terminal board.
4. After all connections are complete, dress the extra ribbon cable length toward the top of the rough-in frame.
5. This completes the installation of the expansion module. Refer to the IMA-4406 Installation Instructions "Connecting the Antenna" to complete the master installation.

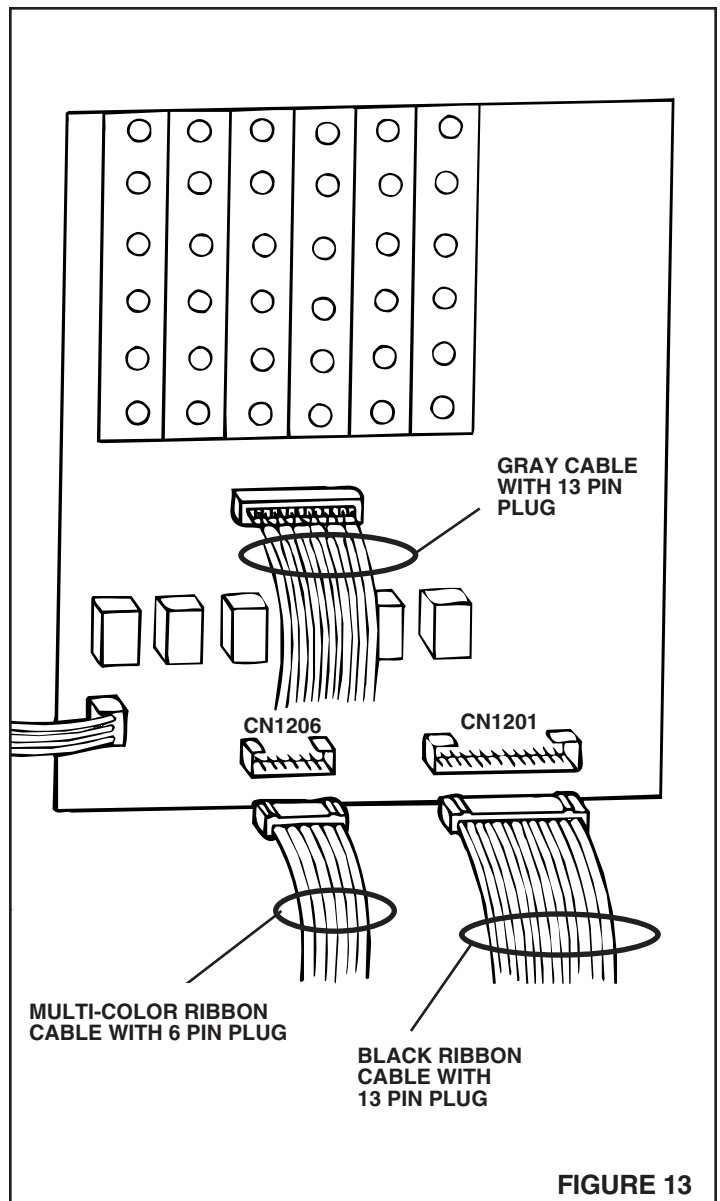
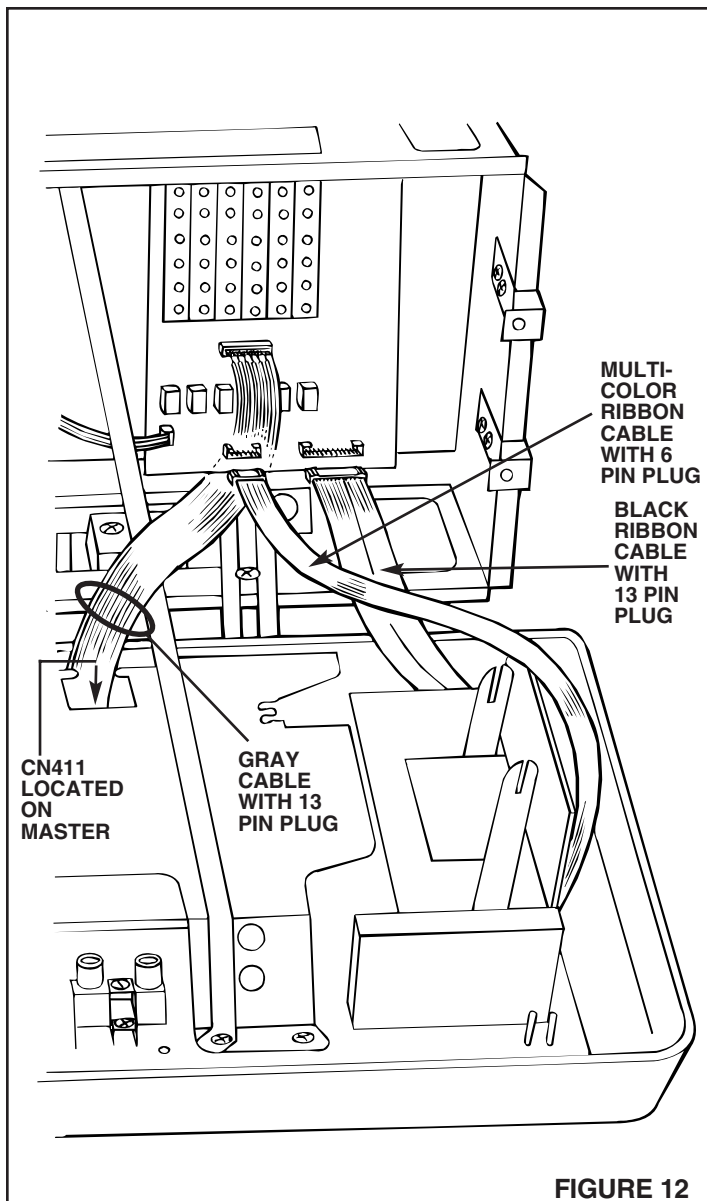
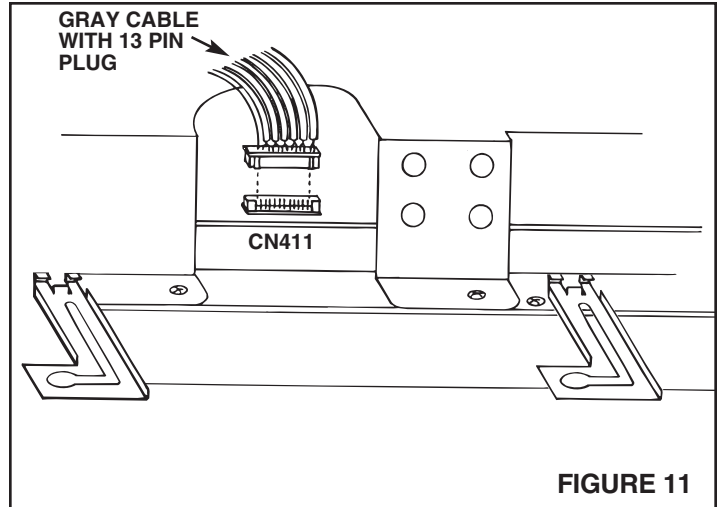

NuTone®

Two Year Limited Warranty

WARRANTY OWNER: NuTone warrants to the original consumer purchaser of its products that such products will be free from defects in materials or workmanship for a period of two (2) years from the date of original purchase. **THERE ARE NO OTHER WARRANTIES, EXPRESS OR IMPLIED, INCLUDING, BUT NOT LIMITED TO, IMPLIED WARRANTIES OF MERCHANTABILITY OR FITNESS FOR A PARTICULAR PURPOSE.**

During this two year period, NuTone will, at its option, repair or replace, without charge, any product or part which is found to be defective under normal use and service. **THIS WARRANTY DOES NOT EXTEND TO FLUORESCENT LAMP STARTERS OR TUBES, FILTERS, DUCT, ROOF CAPS, WALL CAPS AND OTHER ACCESSORIES FOR DUCTING.** This warranty does not cover (a) normal maintenance and service or (b) any products or parts which have been subject to misuse, negligence, accident, improper maintenance or repair (other than by NuTone), faulty installation or installation contrary to recommended installation instructions.

The duration of any implied warranty is limited to the one year period as specified for the express warranty. Some states do not allow limitation on how long an implied warranty lasts, so the above limitation may not apply to you.

NUTONE'S OBLIGATION TO REPAIR OR REPLACE, AT NUTONE'S OPTION, SHALL BE THE PURCHASER'S SOLE AND EXCLUSIVE REMEDY UNDER THIS WARRANTY. NUTONE SHALL NOT BE LIABLE FOR INCIDENTAL, CONSEQUENTIAL OR SPECIAL DAMAGES ARISING OUT OF OR IN CONNECTION WITH PRODUCT USE OR PERFORMANCE. Some states do not allow the exclusion or limitation of incidental or consequential damages, so the above limitation or exclusion may not apply to you. This warranty gives you specific legal rights, and you may also have other rights, which vary from state to state. This warranty supersedes all prior warranties.

WARRANTY SERVICE: To qualify for warranty service, you must (a) notify NuTone at the address stated below or telephone 1/800-543-8687, (b) give the model number and part identification and (c) describe the nature of any defect in the product or part. At the time of requesting warranty service, you must present evidence of the original purchase date.

Date of Installation

Builder or Installer

Model No. and Product Description

IF YOU NEED ASSISTANCE OR SERVICE:

For the location of your nearest NuTone Independent Authorized Service Center:

Residents of the contiguous United States Dial Free 1-800-543-8687

Please be prepared to provide:

Product model number • Date and Proof of purchase • The nature of the difficulty

Residents of Alaska or Hawaii should write to: NuTone Inc. Attn: Department of National Field Service, Madison and Red Bank Roads, Cincinnati Ohio 45227-1599.

Residents of Canada should write to: Broan-NuTone Canada, 1140 Tristar Drive, Mississauga, Ontario, Canada L5T 1H9.

Rev. 01/2000