

Chime Module

MODEL: IA-28

For use with Models IM-2003, IM-3204, IM-3003, IM-3103, IM-3303, IMA-4006, IM-4006, IM-4406, IM-5000, IM-5006 or SR-9000 Series Radio Intercom, Selective Call Intercom and Stereo Receiver Systems.

MOUNTING CHIME MODULE - MODELS IM-3204 or SR-9000

Refer to Figure 1.

1. Be sure power is removed from master before installing chime module.
2. Align the chime module with the plastic molded mounting bracket located in the master unit. Apply firm, even pressure to each side of the chime module. The chime module will snap into place. Fasten module to panel with one screw (supplied with chime module).
3. Plug 4 pin plug from chime module into the mating jack on the master board so red stripe on 4 wire cable is closest to top of master unit (be sure the plug is aligned correctly with the master stations jack).

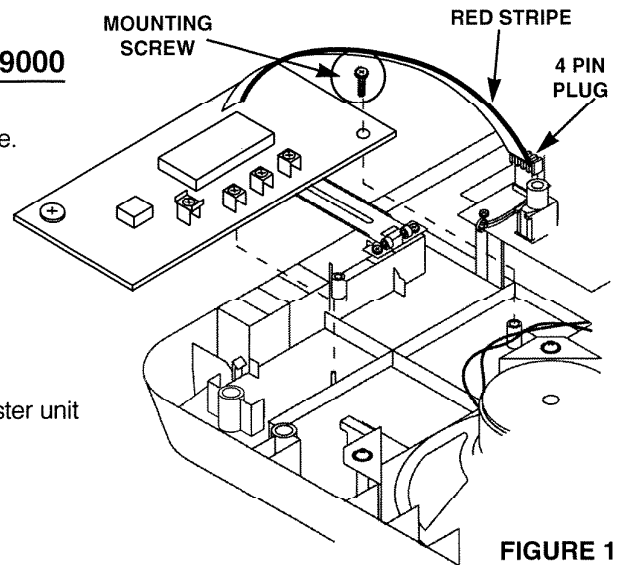

FIGURE 1

MOUNTING CHIME MODULE – MODEL IM-3303

Refer to Figure 2.

1. Be sure power is removed from master before installing chime module.
2. Align the chime module with the plastic molded mounting bracket located in the master unit. Apply firm, even pressure to each side of the chime module. The chime module will snap into place. Fasten module to panel with one screw (supplied with chime module).
3. Plug 4 pin plug from chime module into the mating jack on master board so red stripe on 4 wire cable is closest to top of master unit (be sure the plug is aligned with the master stations jack).

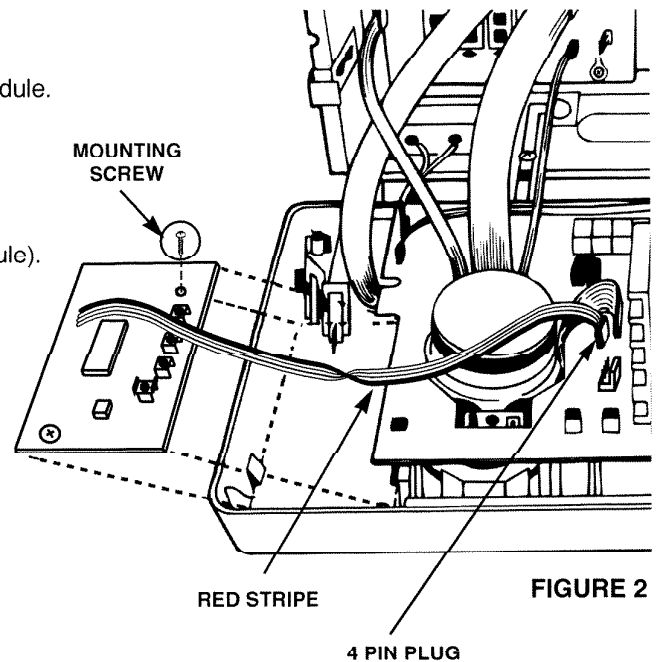

FIGURE 2

MOUNTING CHIME MODULE – MODEL IM-4406

Refer to Figure 3.

1. Be sure power is removed from master before installing chime module.
2. Align the chime module with the plastic molded mounting bracket located in the master unit. Apply firm, even pressure to each side of the chime module. The chime module will snap into place.
3. Plug 4 pin plug from chime module into the mating jack on the master. When properly installed, the ribbon cable will point away from the master station's circuit boards, as illustrated (be sure the plug is aligned correctly with the master stations jack).

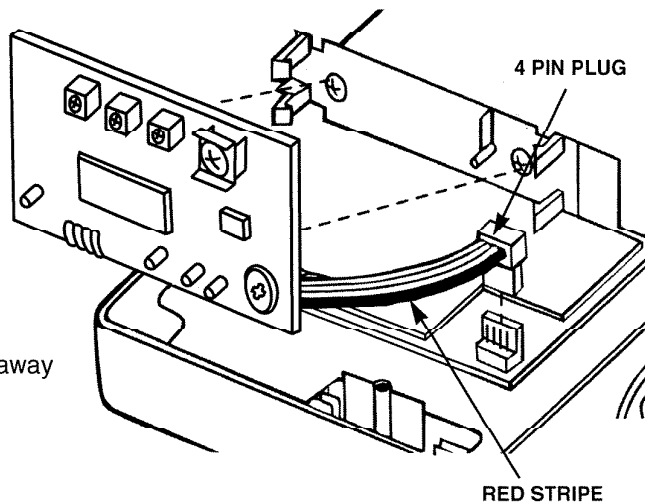

FIGURE 3

MOUNTING CHIME MODULE – IM-5000

Refer to Figure 4.

1. Be sure power is removed from master before installing chime module.
2. Align the chime module with the left plastic molded mounting bracket, then lower the right side of the module until it snaps into place. Fasten module to base with one screw (supplied with chime module).
3. Insert 4 pin plug from chime module into the mating jack on the master marked "CHIME MODULE". Position the cabled side of the connector closest to the heat sink when plugged into the 4 pin jack. The red stripe on the ribbon cable is positioned towards the bottom of the unit (be sure the plug is aligned correctly with the master station jack).

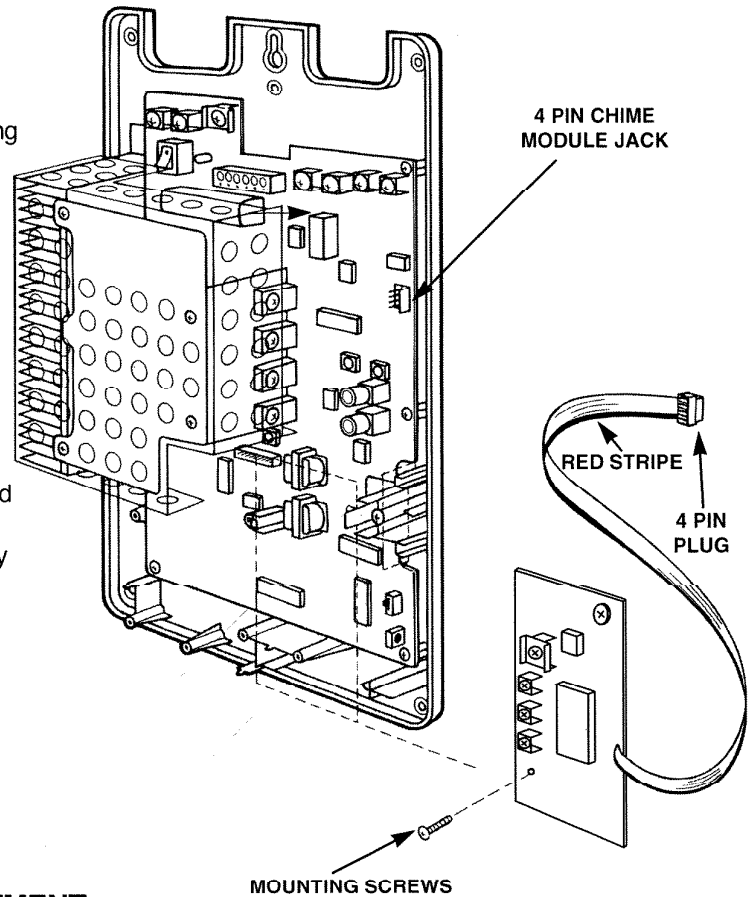

FIGURE 4

WIRING CONNECTIONS & VOLUME ADJUSTMENT

1. Refer to Figure 5. Connect pushbutton wires to screw terminals on the Chime Module as follows:
 - One front pushbutton wire to the screw terminal marked FRONT
 - One rear pushbutton wire to the screw terminal marked REAR
 - One side pushbutton wire to the screw terminal marked SIDE
 - Connect all common pushbutton wires to large screw terminal marked PB COMMON.
2. **NOTE:** Pushbuttons may be connected as desired. The terminal marked FRONT plays an 8-note Westminster chime; the terminal marked REAR plays a 1-note chime; the terminal marked SIDE plays a 2-note chime.
3. Reapply power.
4. Adjust volume control on chime module clockwise to increase chime volume.

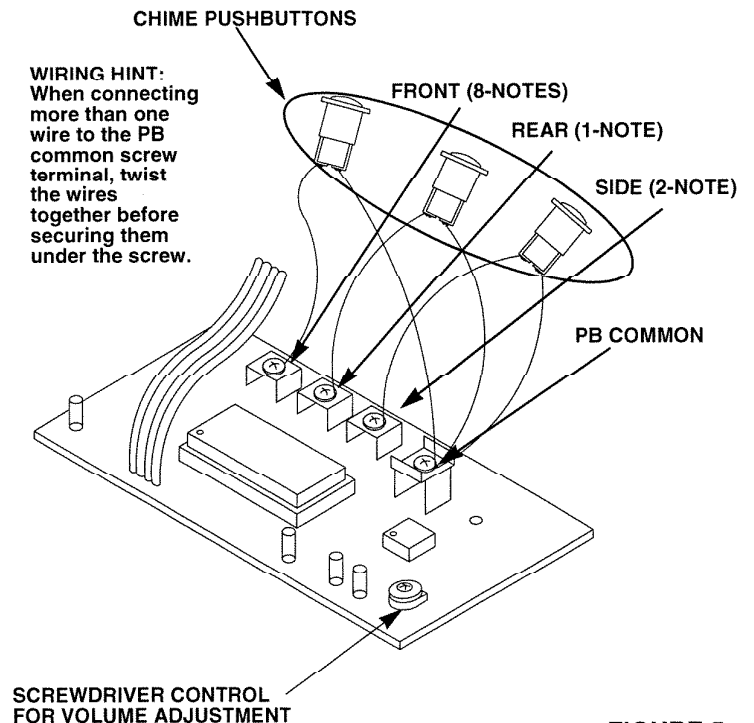

FIGURE 5

NuTone®

Two Year Limited Warranty

WARRANTY OWNER: NuTone warrants to the original consumer purchaser of its products that such products will be free from defects in materials or workmanship for a period of two (2) years from the date of original purchase. **THERE ARE NO OTHER WARRANTIES, EXPRESS OR IMPLIED, INCLUDING, BUT NOT LIMITED TO, IMPLIED WARRANTIES OF MERCHANTABILITY OR FITNESS FOR A PARTICULAR PURPOSE.**

During this two year period, NuTone will, at its option, repair or replace, without charge, any product or part which is found to be defective under normal use and service. THIS WARRANTY DOES NOT EXTEND TO FLUORESCENT LAMP STARTERS OR TUBES, FILTERS, DUCT, ROOF CAPS, WALL CAPS AND OTHER ACCESSORIES FOR DUCTING. This warranty does not cover (a) normal maintenance and service or (b) any products or parts which have been subject to misuse, negligence, accident, improper maintenance or repair (other than by NuTone), faulty installation or installation contrary to recommended installation instructions.

The duration of any implied warranty is limited to the one year period as specified for the express warranty. Some states do not allow limitation on how long an implied warranty lasts, so the above limitation may not apply to you.

NUTONE'S OBLIGATION TO REPAIR OR REPLACE, AT NUTONE'S OPTION, SHALL BE THE PURCHASER'S SOLE AND EXCLUSIVE REMEDY UNDER THIS WARRANTY. NUTONE SHALL NOT BE LIABLE FOR INCIDENTAL, CONSEQUENTIAL OR SPECIAL DAMAGES ARISING OUT OF OR IN CONNECTION WITH PRODUCT USE OR PERFORMANCE. Some states do not allow the exclusion or limitation of incidental or consequential damages, so the above limitation or exclusion may not apply to you. This warranty gives you specific legal rights, and you may also have other rights, which vary from state to state. This warranty supersedes all prior warranties.

WARRANTY SERVICE: To qualify for warranty service, you must (a) notify NuTone at the address stated below or telephone 1/800-543-0007, (b) give the model number and part identification and (c) describe the nature of any defect in the product or part. At the time of requesting warranty service, you must present evidence of the original purchase date.

Date of Installation _____ Builder or Installer _____

Model No. and Product Description _____

IF YOU NEED ASSISTANCE OR SERVICE:

For the location of your nearest NuTone Independent Authorized Service Center:

Residents of the contiguous United States Dial Free 1-800-543-8687

Please be prepared to provide:

Product model number • Date and Proof of purchase • The nature of the difficulty

Residents of Alaska or Hawaii should write to: NuTone Inc. Attn: Department of National Field Service, 4820 Red Bank Road, Cincinnati Ohio 45227-1599

Residents of Canada should write to: Broan-NuTone Canada, 1140 Tristar Drive, Mississauga, Ontario, Canada L5T 1H9.

Rev. 03/2001

Product specifications subject to change without notice.

NuTone®

4820 Red Bank Road, Cincinnati, Ohio 45227
Printed in China, Rev. 4/01, Part No. 62902