

Instruction 510-0402

05-10-2016

Copyright © 2016

Version 1

by S&S® Cycle, Inc.

All rights reserved.
Printed in the U.S.A.

S&S® Cycle, Inc.

14025 Cty Hwy G PO Box 215

Viola, Wisconsin 54664

Phone: 608-627-1497 • Fax: 608-627-1488

Technical Service Phone: 608-627-TECH (8324)

Technical Service Email: sstech@sscycle.com

Website: www.sscycle.com



Installation Instructions: S&S Complete Gear Drive Cam Chest Kit For 1999-'06 Harley-Davidson® Big Twins

DISCLAIMER:

Many S&S parts are designed for high performance, closed course, racing applications and are intended for the very experienced rider only. The installation of S&S parts may void or adversely affect your factory warranty. In addition such installation and use may violate certain federal, state, and local laws, rules and ordinances as well as other laws when used on motor vehicles used on public highways. Always check federal, state, and local laws before modifying your motorcycle. It is the sole and exclusive responsibility of the user to determine the suitability of the product for his or her use, and the user shall assume all legal, personal injury risk and liability and all other obligations, duties, and risks associated therewith.

NOT LEGAL FOR SALE OR USE IN CALIFORNIA ON ANY POLLUTION CONTROLLED MOTOR VEHICLES

SAFE INSTALLATION AND OPERATION RULES:

Before installing your new S&S part it is your responsibility to read and follow the installation and maintenance procedures in these instructions and follow the basic rules below for your personal safety.

- Gasoline is extremely flammable and explosive under certain conditions and toxic when breathed. Do not smoke. Perform installation in a well ventilated area away from open flames or sparks.
- If motorcycle has been running, wait until engine and exhaust pipes have cooled down to avoid getting burned before performing any installation steps.
- Before performing any installation steps disconnect battery to eliminate potential sparks and inadvertent engagement of starter while working on electrical components.
- Read instructions thoroughly and carefully so all procedures are completely understood before performing any installation steps. Contact S&S with any questions you may have if any steps are unclear or any abnormalities occur during installation or operation of motorcycle with a S&S part on it.
- Consult an appropriate service manual for your motorcycle for correct disassembly and reassembly procedures for any parts that need to be removed to facilitate installation.
- Use good judgment when performing installation and operating motorcycle. Good judgment begins with a clear head. Don't let alcohol, drugs or fatigue impair your judgment. Start installation when you are fresh.
- Be sure all federal, state and local laws are obeyed with the installation.
- For optimum performance and safety and to minimize potential damage to carb or other components, use all mounting hardware that is provided and follow all installation instructions.
- Motorcycle exhaust fumes are toxic and poisonous and must not be breathed. Run motorcycle in a well ventilated area where fumes can dissipate.

IMPORTANT NOTICE:

Statements in this instruction sheet preceded by the following words are of special significance.



WARNING

Means there is the possibility of injury to yourself or others.



CAUTION

Means there is the possibility of damage to the part or motorcycle.

NOTE

Other information of particular importance has been placed in italic type.

S&S recommends you take special notice of these items.

WARRANTY:

All S&S parts are guaranteed to the original purchaser to be free of manufacturing defects in materials and workmanship for a period of twelve (12) months from the date of purchase. Merchandise that fails to conform to these conditions will be repaired or replaced at S&S's option if the parts are returned to us by the purchaser within the 12 month warranty period or within 10 days thereafter.

In the event warranty service is required, the original purchaser must call or write S&S immediately with the problem. Some problems can be rectified by a telephone call and need no further course of action.

A part that is suspect of being defective must not be replaced by a Dealer without prior authorization from S&S. If it is deemed necessary for S&S to make an evaluation to determine whether the part was defective, a return authorization number must be obtained from S&S. The parts must be packaged properly so as to not cause further damage and be returned prepaid to S&S with a copy of the original invoice of purchase and a detailed letter outlining the nature of the problem, how the part was used and the circumstances at the time of failure. If after an evaluation has been made by S&S and the part was found to be defective, repair, replacement or refund will be granted.

ADDITIONAL WARRANTY PROVISIONS:

- (1) S&S shall have no obligation in the event an S&S part is modified by any other person or organization.
- (2) S&S shall have no obligation if an S&S part becomes defective in whole or in part as a result of improper installation, improper maintenance, improper use, abnormal operation, or any other misuse or mistreatment of the S&S part.
- (3) S&S shall not be liable for any consequential or incidental damages resulting from the failure of an S&S part, the breach of any warranties, the failure to deliver, delay in delivery, delivery in non-conforming condition, or for any other breach of contract or duty between S&S and a customer.

Introduction

The S&S Complete Cam Chest Kit is a one-part-number solution to replace all the components in the cam chest of 1999-'06 Harley-Davidson® big twins, except 2006 Dyna models, and upgrade to S&S performance camshafts at the same time. Complete Cam Chest Kits are available for the most popular S&S cams. Due to the limited lift capability of the valve springs in 1999-'04 engines, some installations will require the installation of high lift valve springs, not included in this kit. See Chart 1.

COMPATIBILITY NOTES:

- Pinion shaft run out must be verified before installing gear drive camshafts. (.003" max)
- S&S® Gear Drive is not compatible with camshafts designed for the stock chain cam drive. S&S Gear Drive must be used with S&S gear drive camshafts.
- Except for the 509G, and 510G, the S&S® gear driven camshaft kits are not compatible with stock valve springs in 1999-'04 engines.



1999-'04 stock valve springs will accommodate cam shafts with up to .510" lift. This includes S&S 509 and 510 cams. 2005 and later stock valve springs can accommodate camshafts with up to .585" lift. If cams are installed that exceed the lift capacity of the stock valve springs, a set of high performance valve springs must be installed that can handle the additional lift.

- When using S&S gear drive camshafts with stock Harley-Davidson® pistons, valve-to-piston clearance may need to be checked. Clearance should be at least .060" intake and .080" exhaust.
- If stock Harley-Davidson® heads are decked, valve to piston clearance must be checked. If insufficient clearance is found, piston valve pockets must be modified. Clearance should be a minimum of .060".



Incorrect installation can cause engine damage not covered under warranty.



Failure to install components correctly can result in sudden engine seizure. Engine seizure may result in serious injury to motorcycle operator, passenger, or others.

Special Tools Required

- Magnetic Tappet tool or clip
- Sprocket locking tool H-D® #42314
- Cam chain tensioner unloader H-D® #42313
- Camshaft remover/installer H-D® #43644
- Needle bearing remover/installer H-D® #42325
- Dial indicator and flex arm
- Torque wrench – in-lb
- Torque wrench – ft-lb

Disassembly

1. Disconnect negative battery cable to eliminate potential sparks and inadvertent engagement of starter while working on motorcycle.
2. Remove spark plugs and pushrod cover clips. Collapse pushrod covers to expose pushrods.
3. Safely elevate and stabilize rear of motorcycle. Place transmission in high gear. Turn rear wheel to rotate engine until both lifters and pushrods for either cylinder are at lowest point on camshaft (TDCC – Top Dead Center Compression). Both intake and exhaust pushrods for that cylinder will not be under pressure from the valve springs and will rotate with light finger pressure.

NOTE: As a time-saving measure, the stock pushrods can be removed with bolt cutters. Be sure to heed cautions and warnings in these instructions.

SPECIFICATIONS FOR S&S® GEAR DRIVE CAMSHAFTS FOR HARLEY-DAVIDSON® TWIN CAM 88° ENGINES									
Cam Name	Lobe	Timing		Duration	Lift	Centerline	TDC Lift	99-04 Models Works with stock valve springs	05-'06 Models Works with stock valve springs
		Open	Close						
509G	Int	18°	18°	216°	0.509"	90°	.0174"	X	X
	Exh	46°	11°	237°		107.5°	0.140"		
510G	Int	20°	38°	238°	0.510"	99°	0.187"	X	X
	Exh	52°	20°	252°		106°	0.179"		
551G*	Int	17°	19°	216°	0.550"	91°	0.178"		X
	Exh	41°	17°	238°		102°	0.170"		
585G	Int	20°	45°	245°	0.585"	102.5°	0.186"		X
	Exh	60°	20°	260°		110°	0.179"		

*Easy Start Camshafts - See special notes on S&S Easy Start Cams on Page X

Chart 1

4. If you wish to save the stock pushrods, follow the procedure in the Harley-Davidson® service manual for pushrod removal. However, since the Complete Cam Chest Kits include S&S Quickee pushrods, stock pushrods may be cut out of the engine to save time. Cut pushrods for cylinder that is at TDC with bolt cutter and remove pushrods and pushrod covers from engine. Rotate engine to place pushrods for other cylinder at their lowest point (TDCC). Cut and remove remaining pushrods.

CAUTION

Cutting pushrods with a saw or cutoff wheel may result in debris entering engine, causing extensive engine damage not covered under warranty.

WARNING

Cutting pushrods when they are under spring pressure can result in pushrod parts being ejected with considerable force, and can cause bodily injury. Make sure piston is a TDCC.

5. Remove lifter covers from crankcase.
6. Remove engine cam cover and gasket. It is not necessary to remove ignition sensor from cover.
7. Remove lifters with a magnetic tappet tool or a tool made from a large binder clip. See **Picture 1**.

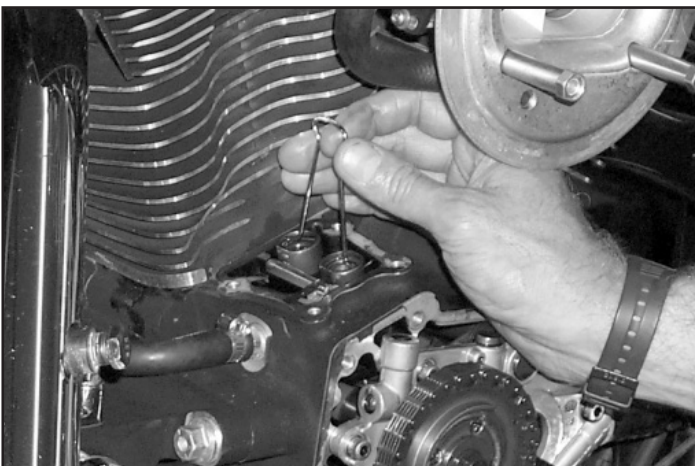

Picture 1

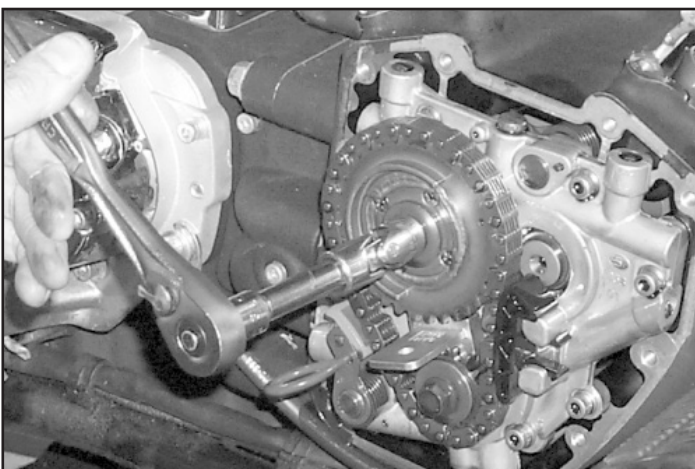

Picture 2

8. Install Harley-Davidson® sprocket locking tool H-D® #42314 to secure sprockets and remove bolts and washers from cam drive sprocket and crankshaft sprocket. See **Picture 2**.
9. Use Harley-Davidson® cam chain tensioner unloader H-D® #42313 to move tensioner away from primary cam chain. Secure tensioner with retention pin. See **Picture 3**.



Picture 3

10. Working gradually around edge of each sprocket, carefully pry sprockets loose. Remove sprocket and chain assembly. Save the washer from the crankshaft pinion sprocket.
11. Remove chain guide. See **Picture 4**.

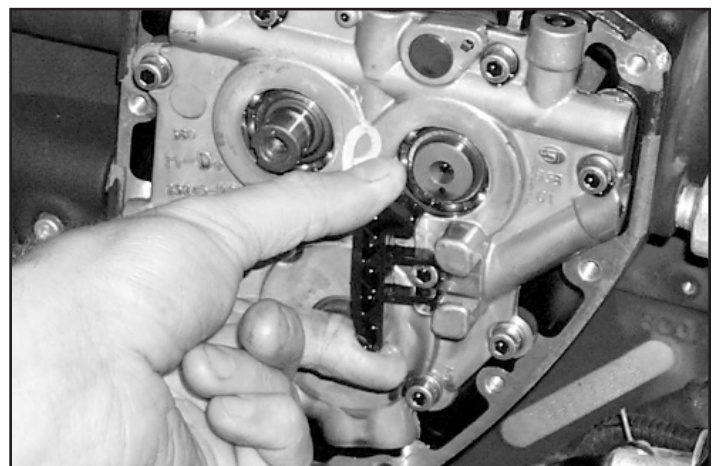

Picture 4

12. Following sequence shown in **Figure 1**, alternately loosen and remove oil pump bolts.

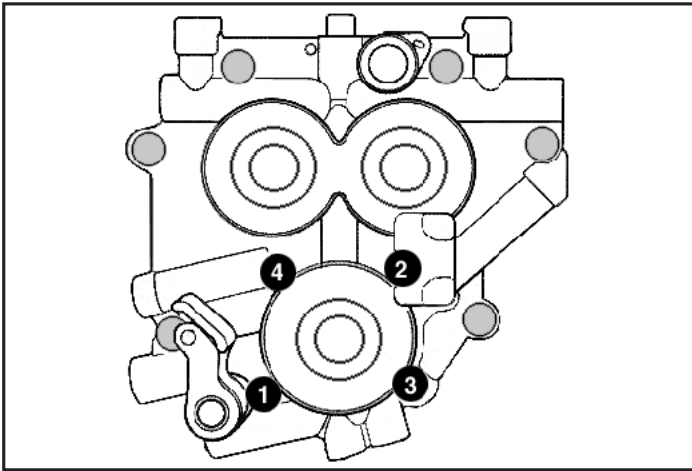

Figure 1

13. Following sequence shown in **Figure 2**, alternately loosen and remove cam support plate bolts.

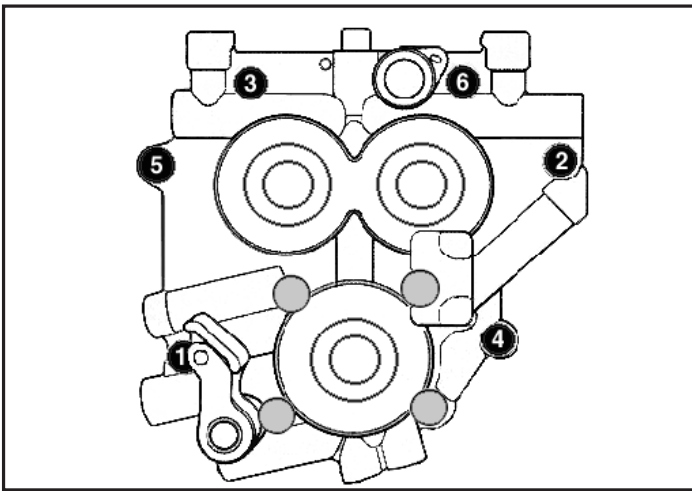

Figure 2



Failure to remove and install bolts according to correct procedure may result in parts damage not covered under warranty.

14. Carefully remove stock cam support plate assembly from case. Cam support plate and cams may be discarded.



Picture 5

15. Remove the stock oil pump. Stock oil pump may be discarded.

16. Check pinion shaft runout. Place an indicator on the end of pinion shaft at cam support plate bushing surface and rotate engine; reading must be .003" or less total indicated runout (TIR). If reading is greater than .003" TIR the crankshaft must be repaired or replaced to correct excess runout before installing gear drive cams. See **Picture 5**



Pinion shaft runout must be checked before installing gear drive cams. Total indicated runout (TIR) at the end of pinion shaft at cam support plate bushing surface must be .003" or less. If reading is greater than .003" TIR the crankshaft must be repaired or replaced to correct excess runout before installing gear drive cams. Excess runout may lead to engine damage not covered under S&S warranty.

17. Clean and flush your oil tank and oil lines. Any foreign matter that has accumulated in your oil tank may be sucked through your new oil pump. Oil pans with riveted-in baffle can be very hard to clean, it is very important to remove all debris from the pan. Replace the oil filter.

Assembly

1. When installing 551G or 585G camshafts clearance between pinion bearing boss and rear cam lobe must be checked. Place cam to be installed in inner cam bearing and rotate to observe clearances. See **Pictures 6 & 7**. If clearancing is required, remove just enough material to provide .030" clearance between top of cam lobe and pinion bearing boss when camshaft is rotated in inner needle bearing. Also check clearance between all cam lobes and tappet guide bosses. To avoid contamination of engine with chips, tape off all holes in the gear case with duct tape and thoroughly clean the gear case with parts cleaner or solvent after clearancing is performed.

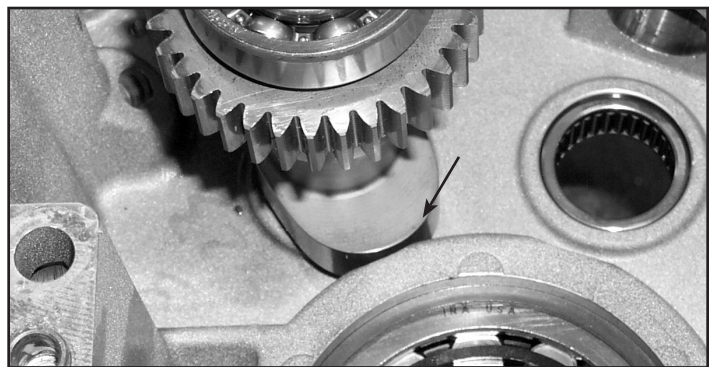

Picture 6



Picture 7

- Carefully remove inner camshaft needle bearings from crankcase with Harley-Davidson® camshaft needle bearing remover/installer H-D® #42325, and replace them with new bearings provided in kit. Cam bearings must be full complement bearing with no spacers between the needle rollers.
- Install hydraulic tensioner oil block off plates to front and rear of cam support plate. Apply blue thread locker to fasteners and tighten to 100 in-lb. See **Pictures 8 & 9**.

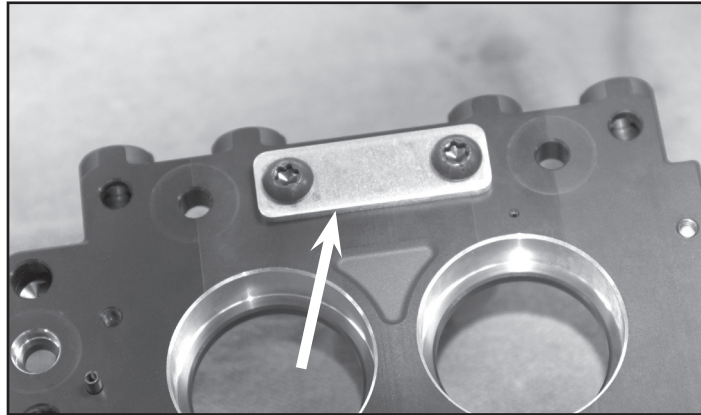

Picture 8

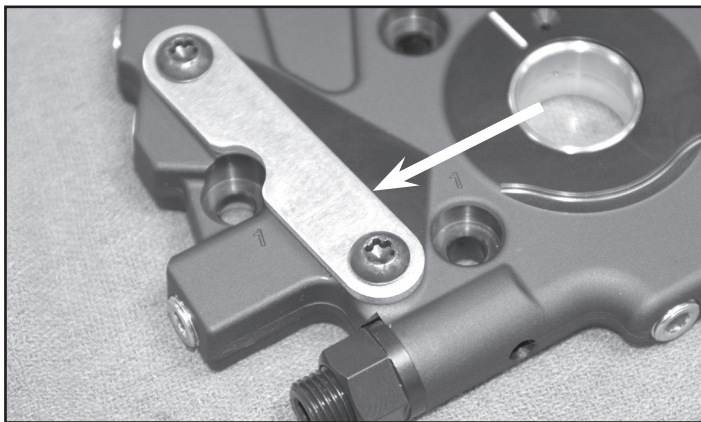

Picture 9

NOTE: Do not reuse outer cam bearings. The S&S Gear Drive Cams require that ball bearings be used for both front and rear camshaft outer bearings. These bearings are included in the kit.

- Apply assembly lube to outer races of cam bearings and bearing bores in S&S cam support plate. With cam support plate positioned securely in a hydraulic press, use Harley-Davidson® camshaft remover/installer H-D® #43644 to install both bearings. See **Picture 10**

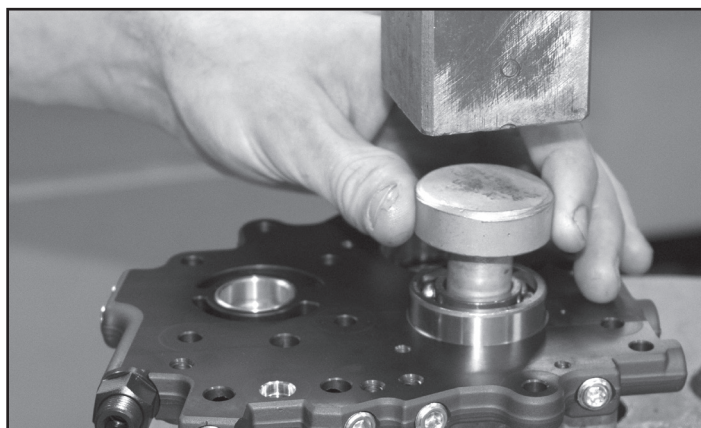

Picture 10

NOTES:

- Check clearance between bearing retainer and woodruff keys securing inner gears to cams. If clearance is less than .030", remove material from retainer, to provide inadequate clearance between key and retainer. See **Picture 11** below.

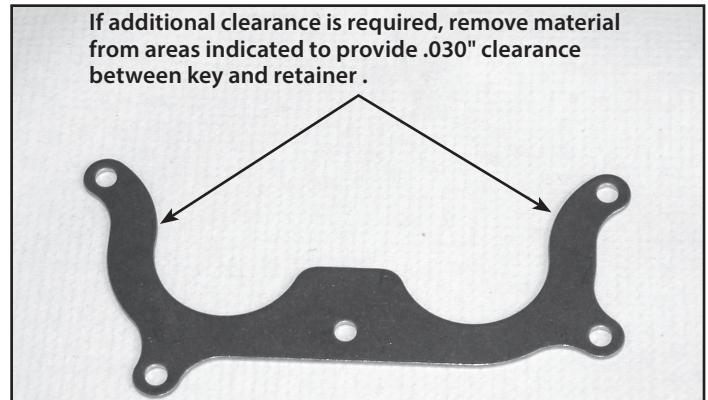

Picture 11

- Some early 1999 model engines do not have a chain oiler boss. See **Pictures 12 and 13**. If your engine does not have this boss, screw #500-0346 must be installed to block the oil hole in the back side of the cam plate. Install with red thread locker and tighten to 70 in-lb. See **Figure 4** on next page.

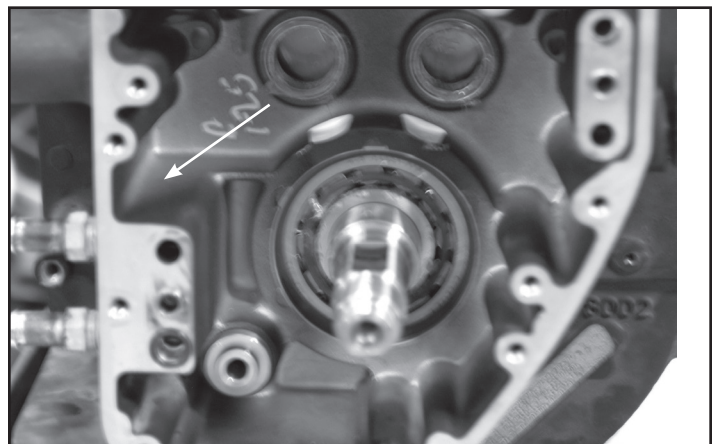

Picture 12

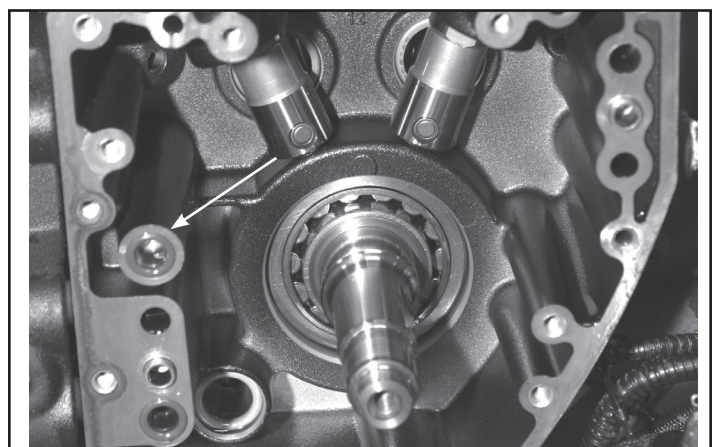

Picture 13

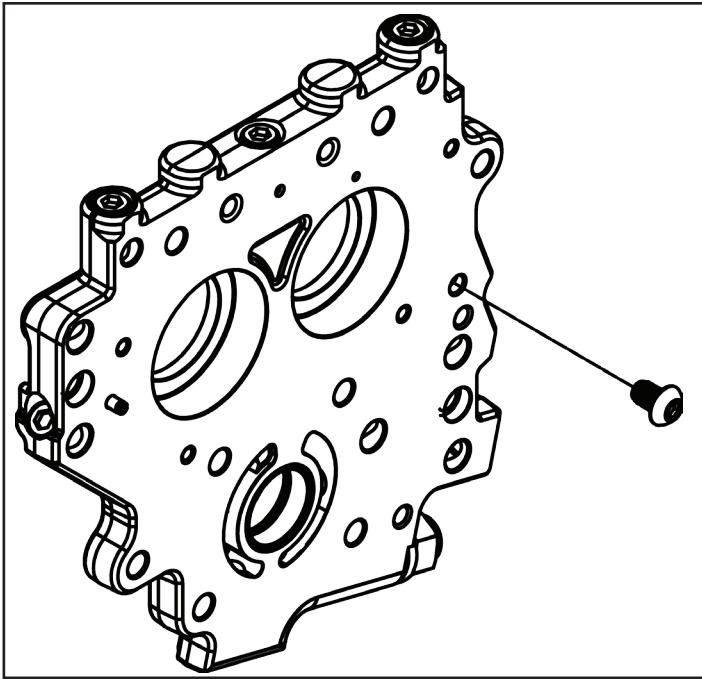

Figure 4

5. Apply assembly lube to bearing surface of front (shorter) camshaft and to the inside of front cam bearing. Support bearing by inner race and press camshaft all the way into bearing. Install retaining ring on outer end of front camshaft.
6. Apply assembly lube to bearing surface of rear (longer) camshaft and inside the rear bearing. Support bearing by inner race. Align front and rear camshaft gear timing marks as shown in **Figure 5**. Press camshaft all the way into bearing.

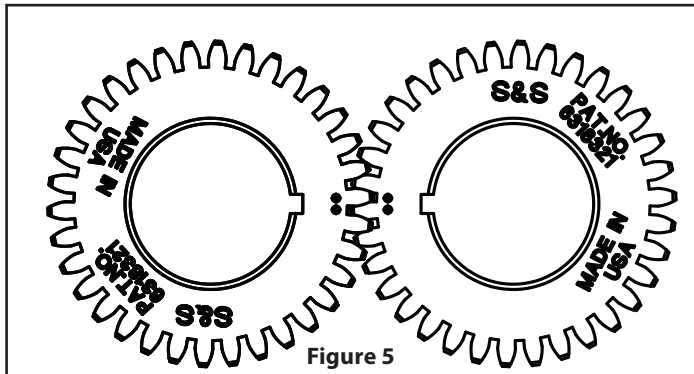
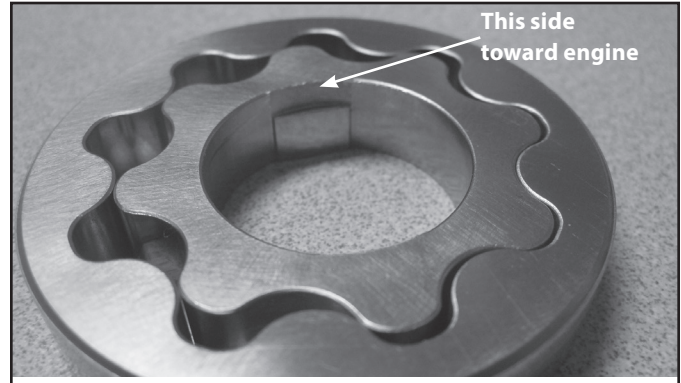

Figure 5

7. Remove S&S oil pump from package and inspect. Make sure pump has all parts shown in assembly drawing on Page 10. All S&S Cam Chest Kits contain a 2007-later style oil pump because the S&S 1999-'06 style cam plate is machined for a late style pump.
 8. Disassemble oil pump and wash all parts. Check to make sure all plugs have been installed.
- NOTE: We feel it is easiest to assemble pump into motor one piece at a time.*
9. Install scavenge port O-ring in case (do not install O-ring onto pump). Put some engine oil or assembly lube on the O-ring to make installing the pump housing easier.
 10. **NOTE:** Even if the original stock o-ring appears to be in good condition, it is likely to have become brittle resulting in a poor seal and inadequate crankcase oil scavenging.
 11. Install rear pump housing. Push the housing into the O-ring with your thumb. Make sure it goes in all the way.

12. **Note:** The drive flats on these gears are purposely wider than the stock drive flats. This allows for more freedom of movement. This helps prevent excessive side loading but still gives plenty of engagement for turning the rotors.

13. Apply assembly lube to inner return gear set, and assemble inner gear inside outer gear. Align the inner gear with the flat on the pinion shaft and install gear set into inner pump body as an assembly. Make sure the relief cut side of the inner gear goes toward the engine See **Picture 14**.



Picture 14

Note: Do not mix and match inner and outer gears keep them as sets as they are shipped in the pump.

14. Install two 1/8" x 3/4" dowels into pump housing. See #7 in line drawing on Page 4.
15. Install divider plate
16. Apply assembly lube to second return gear set. Place gear set into outer pump body and install outer pump body onto inner pump body.
17. Place straight edge across front of cam chest and make sure the face of the pump does not protrude past the cam chest gasket surface. **Figure 6**

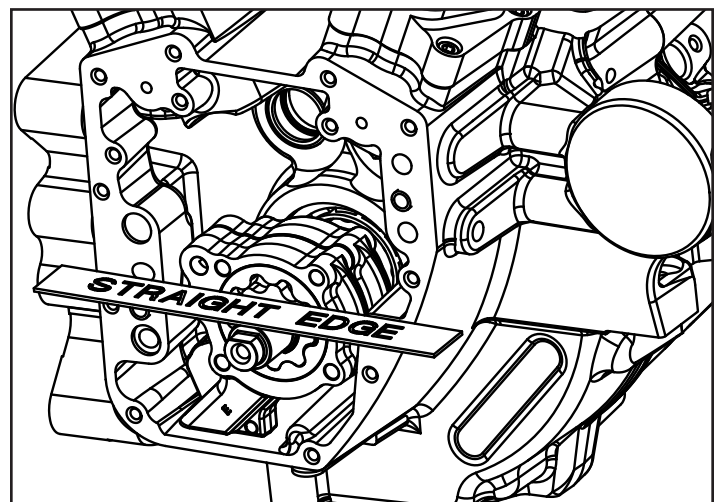

Figure 6

18. If pump protrudes past gasket surface check to see that the pump is installed all the way into the scavenge port O-ring. If this doesn't solve the issue and you cannot see any other areas of interference contact the S&S tech line at 608-627-8324.
19. Apply assembly lube to the .250 wide feed gear set and install into pump. Be sure this does not protrude past the front face of the pump body.

20. Apply a thin layer of assembly lube to cam journals, lobe surfaces, and inner bearing surfaces. Thoroughly lubricate decompression lever of Easy Start Cams. Align camshafts with needle bearings and carefully slide support plate over crankcase dowels.

NOTE: Cam support plate assembly should slide into place without resistance. If resistance is encountered, determine cause and correct problem before proceeding. Do not force cam support plate into position!

21. Loosely install support plate screws with a drop of blue thread locker Alternately tighten screws to 95 in-lbs. torque following sequence shown. See **Figure 2 on Page 4.**

CAUTION

Support plate screws that pass through alignment dowels (See positions 1 & 2 in Figure 2) can be easily stripped. Do not exceed torque recommendation.

22. Install oil pump mounting bolts with a drop of blue thread locker according to procedure found in factory service manual: Gently bottom screws, then back them out 1/4 turn. Center oil pump by rotating engine by hand while snugging down screws. Alternately tighten bolts to 95 in-lbs. torque in sequence shown in **Figure 1 on Page 4.** Before proceeding with installation, verify that inner gears rotate freely and no binding is present.

NOTES:

- Crankshaft and cam drive gears have a light press fit on their respective shafts. Start gears squarely on their shafts and use their mounting bolts to pull them all the way into position.

- Make sure that no metal burrs are raised when installing the gear sets. Burrs can form underneath the gear causing excessive gear run out.

23. Place drive gear key in rear camshaft. Position rear cam drive gear on rear camshaft and key with timing mark outward.

24. Apply a drop of red thread locker to threads of 3/8"-24 x 1.75 Grade 8 cam drive gear bolt. Apply a drop of clean engine oil under bolt flange. Using thick washer provided, install cam drive gear bolt and tighten to 34 ft-lbs. torque. Cams should rotate freely with no binding.

25. Place a dial indicator on a tooth of the rear cam drive gear so that it measures the movement of the teeth of the rear cam drive gear at as close being in line with the direction of rotation as possible. This can be done with a "finger" on the probe as shown in **Picture 15** or by other arrangement. Dial indicator can be secured with a flex mount or by bolting it to the crankcase at the gear cover surface.

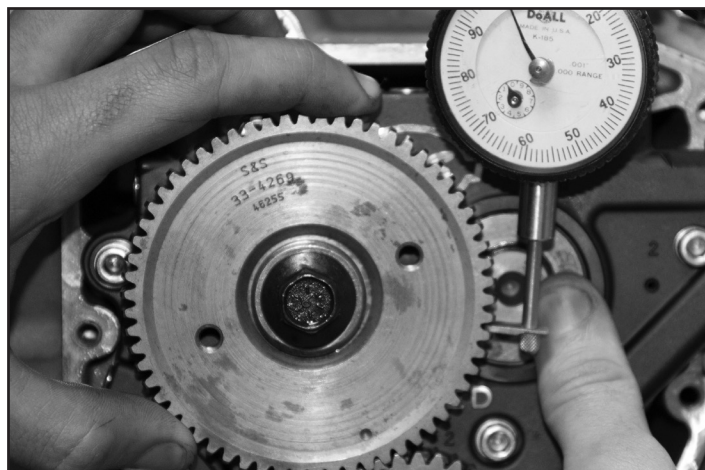

Picture 15

26. Hold the front cam with finger pressure to keep it from rotating, and rock the rear cam drive gear back and forth. Record the amount of gear tooth movement as shown on the dial indicator. Repeat this measurement in four positions at 90° intervals of cam gear rotation. Divide the readings by 2 to correct for the difference in diameters in the inner gears and the outer drive gear. The lowest of the readings after dividing by 2 should be between .0005" and .001". If backlash is not correct, inner rear cam gear must be replaced with either oversized or undersized inner gear. These gears are not included in the cam kit. See line drawing on page 8 for part numbers.

CAUTION

Too much backlash can cause excessive gear noise or clicking caused by the reversing of the forces applied by the lifters to the cam lobes. Insufficient backlash, will cause gears to whine, wear prematurely, create excess heat, and may cause breaking of the gear teeth and engine failure

27. Turn rear wheel to rotate engine so that when the crankshaft pinion gear is installed, the timing mark will line up with the timing mark on the rear cam drive gear. See **Figure 7.**

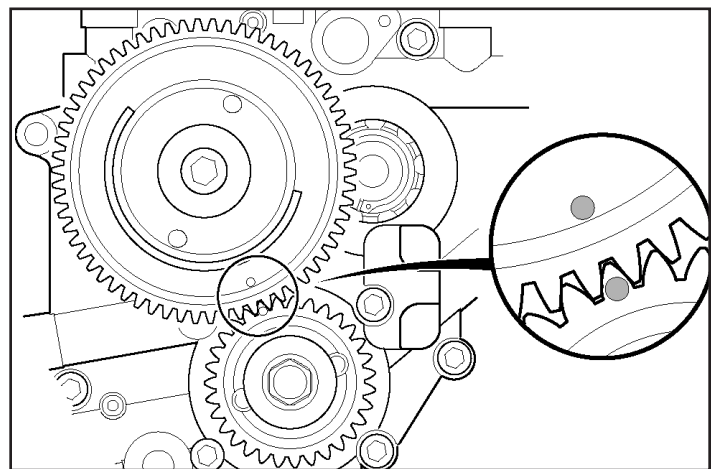

Figure 7

28. Place pinion gear on the pinion shaft with timing mark outward. Apply a drop of red thread locker to threads of 5/16"-18 x 3/4" Grade 8 crankshaft gear bolt, provided in S&S® Camshaft Installation Kit 106-5896. Apply a drop of clean engine oil under bolt flange. Using the washer removed in disassembly step 10, install crankshaft gear bolt and tighten to 25 ft-lbs. torque.

29. To check backlash between the rear cam outer drive gear and the crankshaft pinion gear, place the dial indicator on a tooth of the rear cam outer drive gear. Rock the rear cam outer drive gear back and forth, and record the indicated backlash. Use the rear tire to turn the engine, and check the lash in four positions at 90° intervals on the pinion gear. Since these measurements are taken directly, they are correct as indicated. Do not divide by 2. Backlash measurements for outer gears may vary depending on the total indicated run-out (TIR) of the pinion shaft. The lowest of the four measurements should be between .0005" and .001", but none should be over .002". If backlash is not correct, pinion gear must be replaced with either an oversized or undersized pinion gear. These gears are not included in the cam kit. See line drawing on page 8 for part numbers. If the lowest backlash readings are within specification and the highest reading is over .002", the pinion shaft of the flywheel assembly has too much run out and must be corrected.

NOTE: The rear cam drive gear is slightly larger than the stock drive sprocket and needs to be checked for interference with cam cover before proceeding.

30. Press a small piece of clay or kneadable putty on cam cover mounting boss as shown. See **Figure 8**. Carefully hold cover and cover gasket in position against crankcase. Install mounting bolts (4) near corners of cover finger tight. Push or tap cam cover towards front of engine.

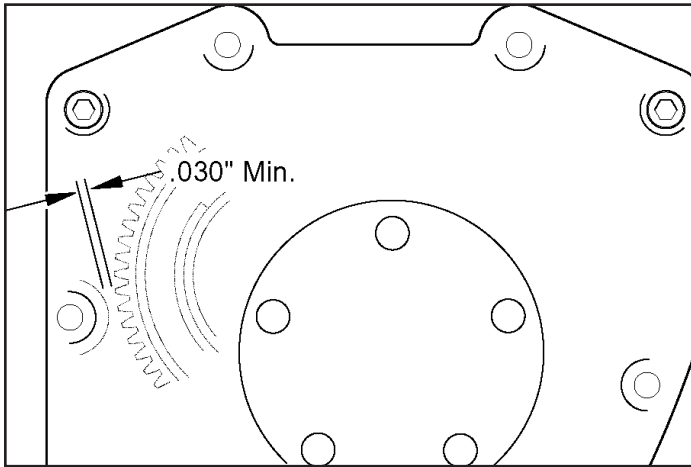

Figure 8

31. Carefully remove cam cover. Determine cover-to-gear clearance by measuring impression left in clay by gear at its thinnest point. Clearance should be .030" or more.

32. If clearance is less than .030", or if cover contacts gear, remove just enough material from cam cover to obtain correct clearance. Repeat steps 30 and 31 if necessary.

CAUTION

Be careful not to grind too deeply and break through to the outside of the cam cover. Damage to cam cover caused by removing too much material is not covered under warranty.

33. Use a new gasket and install cam cover. Tighten cover bolts to 100 in-lbs. in the sequence shown in **Figure 9**.

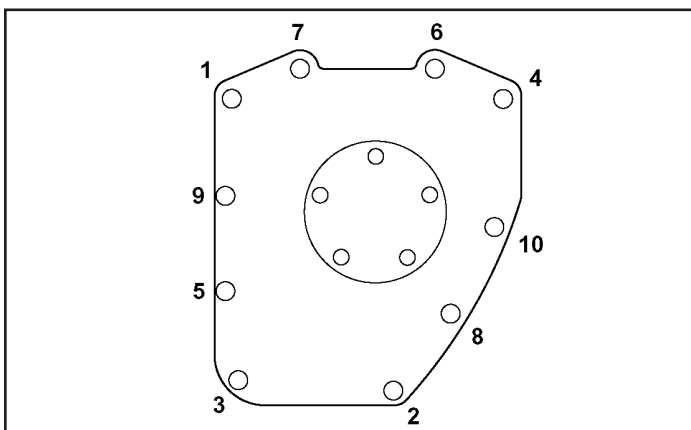

Figure 9

34. Coat S&S tappets with engine oil or assembly lube and install in tappet guide bores.

35. Install tappet cover gasket and tappet cover. Tighten fasteners to 100 in-lb.

36. Refer to the pushrod cover assembly diagram on **Page 9** to determine the correct positions for pushrod cover components and seals. Items 4, 5, and 6 must be reused from stock covers.

37. Clean and inspect the pushrod tubes. Apply a light coat of engine oil to the o-rings and assemble pushrod tubes.

38. To prepare S&S® Quickee pushrods for installation, thread the jam nut off the threads towards the ball end and screw the adjuster into the pushrod tube until the threads disengage and the pushrod can be collapsed.

39. Turn engine so that either cylinder is at Top Dead Center Compression (TDCC).

40. Insert pushrods through tube assemblies and install in appropriate positions for that cylinder.

NOTE: S&S Quickee Pushrods for all big twin engines contain two long and two short pushrods, short for the intake valves, long for the exhaust valves.

41. Hold pushrod so the top ball end is in the rocker arm cup, extend adjusting screw until the bottom ball end just contacts the tappet cup. Lengthen pushrod an additional 4 complete turns (24 flats), to compress hydraulic unit in lifter, and tighten locknut. Allow sufficient time for lifter to bleed down (20 to 30 minutes) before adjusting the other pushrod for that cylinder. Both pushrods must spin freely with finger pressure.

NOTE: S&S Easy Start compression release cams require extra care when adjusting pushrods. Ensure that the tappet is not on the decompression lobe. This will cause incorrect exhaust pushrod adjustment. Rotate the engine in the forward direction and feel for the exhaust tappet to slightly lift (about .030") and set back down on the base circle. This is the proper point to adjust the pushrods.

CAUTIONS

• Failure to allow hydraulic unit to bleed down before rotating engine or adjusting the other pushrod could result in valve-to-valve contact and serious valve train damage. Lifters are bled down when pushrod can be turned with fingertips.

• When installed and adjusted, S&S Quickee Pushrods must have a minimum thread engagement of .500" (Pushrod tube to Adjuster, not including the jam nut) or severe damage to the pushrod as well as your engine may occur. When adjustment is complete, the jam nut must have full thread engagement with the adjuster screw. If you do not have full engagement, the pushrod is not correct for the application or position.

42. Follow above procedure to install and adjust pushrods for other cylinder.

43. Replace pushrod tube clips and spark plugs, and reconnect negative battery cable. Start motorcycle and check for leaks.

NOTES:

• The S&S® Gear Drive Cams require that ball bearings be used for both front and rear outer camshaft bearings to ensure consistent center to center distance between the gears. Since the gear drive does not exert a large side load on the rear camshaft, the higher load handling capacity of the stock roller style bearing is not required.

• Pinion shaft run out must be verified before installing gear drive camshafts. (.003" max)

• S&S recommends replacing stock spring style hose clamps on oil cooler lines, where they attach to the filter adaptor, with crimp style clamps. Spring clamps do not provide adequate clamping force to keep oil lines secure on the hose nipples under extended high rpm operation.

SPECIAL NOTES – S&S Easy Start Cams

- S&S® developed Easy Start cams to allow easy starting with a built in centrifugal compression release. The operation is simple: at cranking speeds, a spring loaded decompression lever opens the exhaust valve slightly, reducing cranking compression. Once the engine fires and exceeds 750 RPM, centrifugal force retracts the lever, allowing the engine to run normally with full compression.
- The various grinds of S&S Easy Start cams are designed to be used with a specific range of displacement and compression ratio. Some EFI engines may not start if the compression is too low.

Cam	Intended Displacement	Intended Compression Ratio
551	88–106	9.0–10.0
570	88–106	9.0–10.0
583	88–106	9.0–10.0
585	88–106	9.2–10.5
625	95+	10.0–10.75
640	95+	10.5–11.5
675	120+	11+

- Stock EFI engines require a minimum of 80 PSI cranking compression, checked with the throttle open, for the ECU to fire the spark plugs.
- Cranking compression numbers are no longer a valid health check of the engine. We recommend performing a leak down test.
- If the lifters have been disassembled or bled down for any purpose, the starter may have difficulty with the initial start. Although the decompression lobe lifts the lifter body, the lifter is not pumped up and it will not lift the exhaust valve. You may need to remove the spark plugs and crank the engine to get oil pressure to the lifters.
- Easy Start cams require no special service. If they are ever removed for any reason however, inspect the mechanism for wear and verify that the lever operates smoothly.
- If your bike is carbureted, the starting routine may be slightly different, allow yourself time to experiment to find the best method.
- When the engine is turned off, you may hear a slight click as the decompression lever resets. This is normal and does no harm.
- If engine speed drops below 900 RPM, you may hear clicking as the decompression lever starts engaging. Idle speed should be adjusted higher. The engine idle should be set at 1000-1100 RPM.

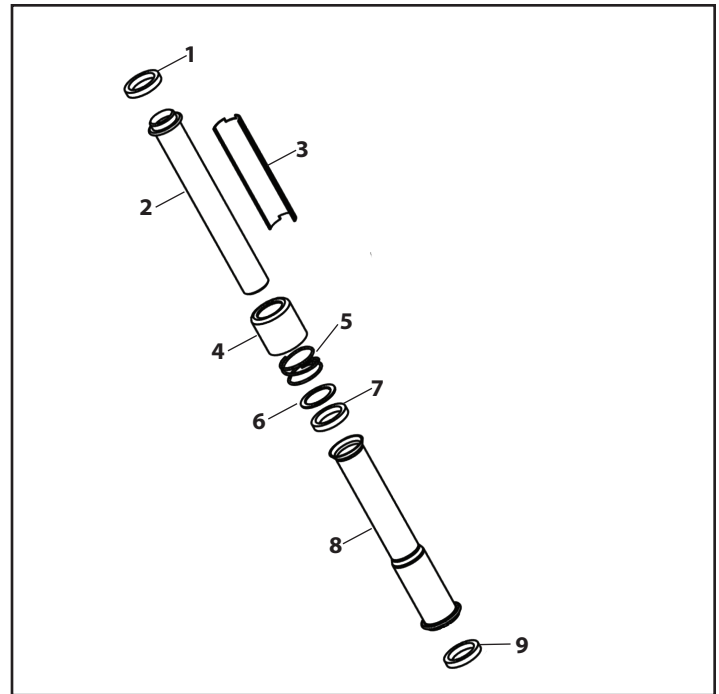

S&S Pushrod Tube Assembly Drawing

1. Top pushrod seal - the thickest o-ring of the three provided in the kit
2. Top Pushrod cover
3. Pushrod cover keeper
4. Cover cap - Not included, use stock part
5. Cover cap spring - Not included, use stock part
6. Cover cap washer - Not included, use stock part
7. Middle seal – the smaller diameter of the thinner o-rings provided in the kit
8. Lower pushrod cover
9. Lower seal – the larger diameter of the thinner o-rings provided in the kit

S&S Cam Support Plate Replacement Parts

1. Cam support plateNA
2. Pressure relief valve31-6082-S
3. Pressure relief spring31-6018
4. Pressure relief adjusting screw 170-0252
5. Pressure relief adjusting screw lock nut 170-0251
6. 1/8" 27 taper pipe plug50-8331
7. Bearing retention plate kit 330-0015
8. Hydraulic tensioner block off kit 106-5723
9. O-ring kit 500-0326
10. Assembly lube (Not pictured)51-9002
11. Loctite #243 Blue .5ml (Not pictured)51-9003
12. Loctite #262 Red .5ml (Not pictured)51-9004

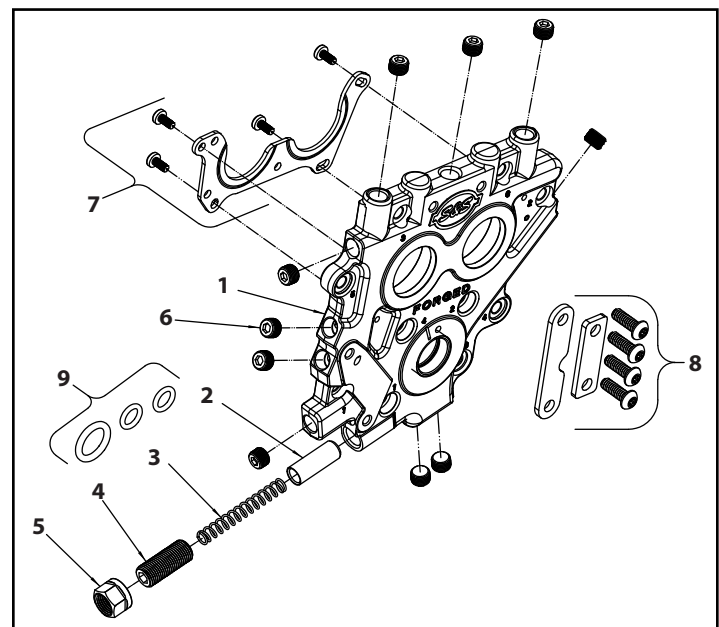

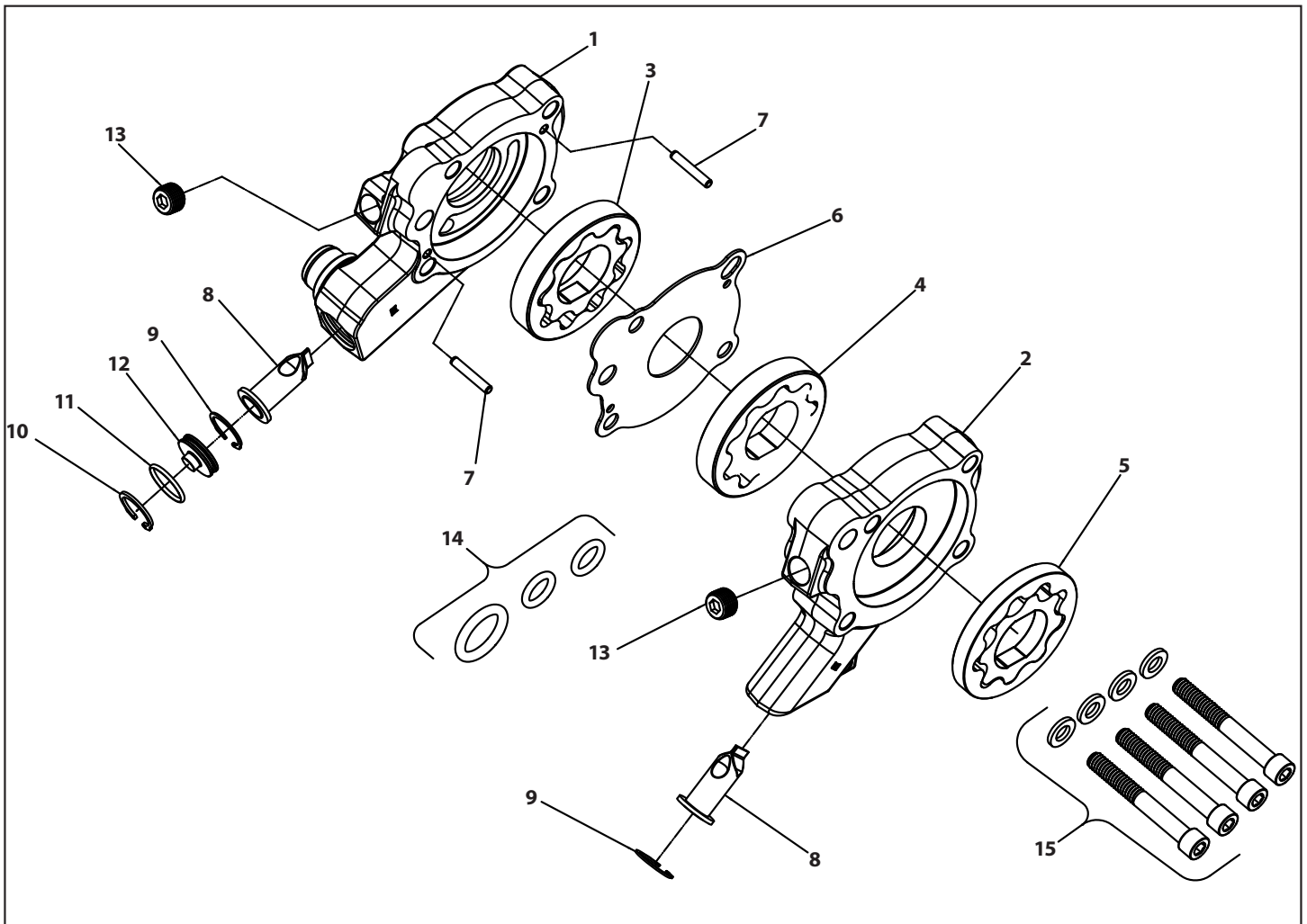

S&S Oil Pump Replacement Parts

- 1. Oil pump body case return section NA
- 2. Oil pump body cam chest return / pressure feed NA
- 3. Oil pump rotor set, flywheel cavity return 310-0644
- 4. Oil pump rotor set, cam chest cavity return36-7021-5
- 5. Oil pump rotor set, supply 310-0561
- 6. Plate, divider 310-0516
- 7. Dowel Pin, .125 x .750 Hardened Steel 106-3794
- 8. Debris screen 310-0546
- 9. Internal Retaining Ring, .625 500-0320
- 10. Internal Retaining Ring, 17mm 500-0209
- 11. O-ring, 1.5mm x 14mm, Viton..... 500-0321
- 12. Oil pump return plug 310-0564
- 13. Plug, Pipe 1/8" 27..... 50-8331
- 14. O-ring kit 500-0326
- 15. Screw, Kit, Oil Pump, 1999-Up BT (1/4" 20 x 2" SHCS w/washers).... 500-0327
- 16. Assembly lube (Not pictured) 51-9002
- 17. Loctite #243 Blue (Not pictured)..... 51-9003
- 18. Loctite #262 Red (Not pictured) 51-9004



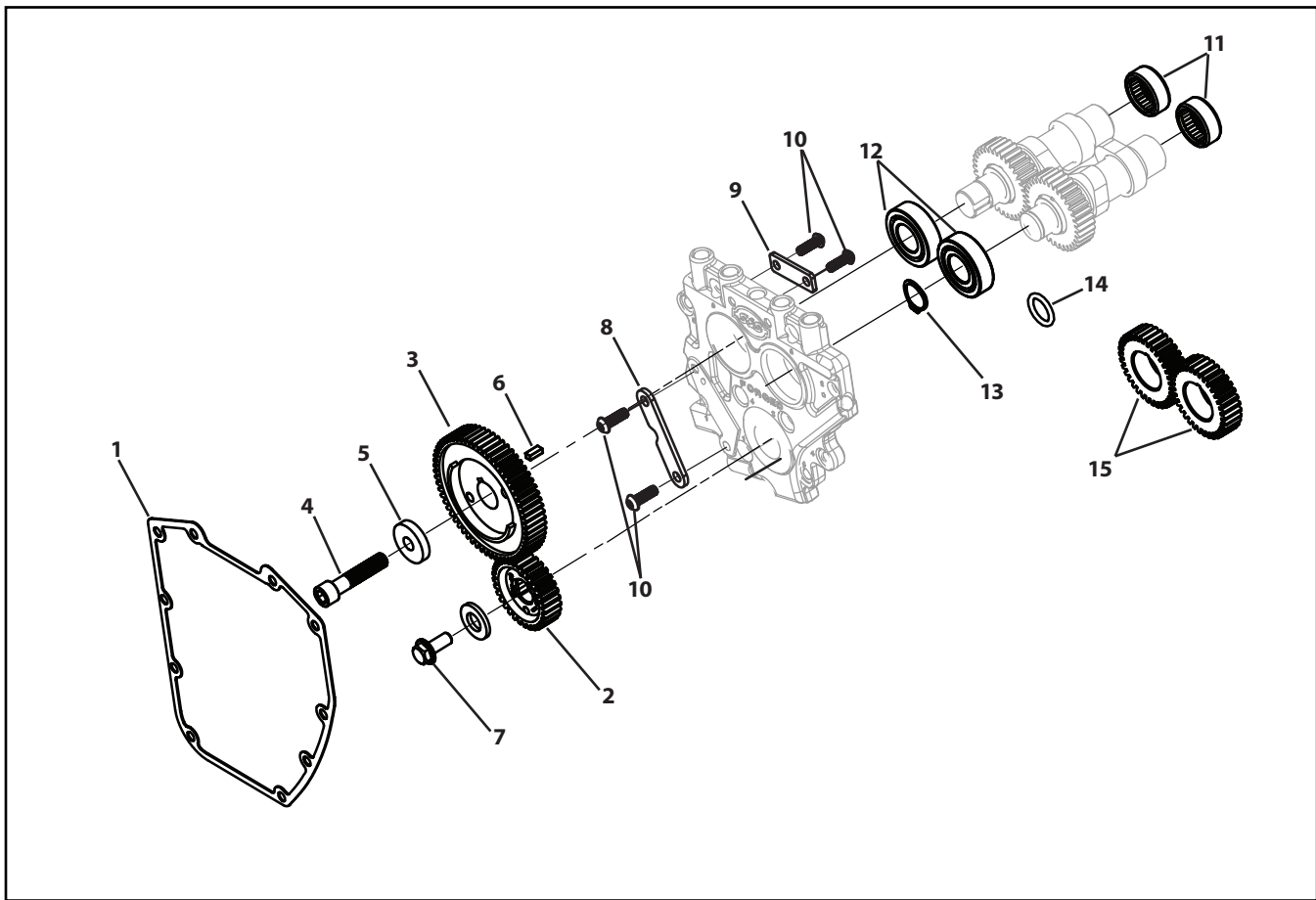

Gear Drive Cam Assembly Parts

1. Gasket, Cam Cover.....	31-2032-5	15. Inner Cam Gears	
2. Pinion Gear,		Current Production (Front or Rear)	
Standard Diameter.....	33-416Z	Standard Diameter (each).....	330-0486
Undersized.....	33-4160X	Undersized (each).....	330-0488
Double Under.....	33-4160XX	Oversized (each).....	330-0489
Oversized.....	33-4160Z	Early Production	
Double Over.....	33-4160ZZ	Front (Includes reference #16).....	33-4272F
3. Rear Outer Cam Drive Gear, Kit		Rear (Includes reference #16)	
(Includes reference #4, 5, & 6).....	106-4882	Standard Diameter.....	33-4272
4. Screw, SHC 3/8" -24 x 13/4".....	50-0132	Undersized.....	33-4272RX
5. Washer, Flat 3/8" x 11/8" x .225".....	50-7056	Oversized.....	33-4272RZ
6. Key, Parallel, .188" x .150" x .420", Steel.....	106-1348	Not Shown	
7. Screw, HHC 5/16" -18 x 3/4".....	50-0100	16. Gear Drive Camshaft Installation Kit	
8. Outer Oil Hole Cover.....	33-4264	(Includes reference #1, 7, 8, 9, & 10).....	106-5896
9. Top Oil Hole Cover.....	33-4265	17. Outer Drive Gear Kit	
10. Screw BHTS 1/4-20 x 3/4".....	50-0288-5	(Includes reference #2, 3, 4, 5 & 6).....	33-4276
11. Inner Cam Needle Bearing (Each).....	31-4080	18. Complete Gear Drive Kit	
12. Bearing, Outer Cam, Ball.....	31-4081	(Includes reference #2, 3, 4, 5, 6, 10 (2 each), & 16).....	33-4275
13. Ring, Retaining.....	50-8061	19. Key, Woodruff .125" x .5" (2).....	50-8223-5
14. Oil Pump Scavenge O-ring.....	50-8039		

All reference to H-D® part numbers is for identification purposes only. We in no way are implying that any of S&S® Cycle's products are original equipment parts or that they are equivalent to the corresponding H-D part number shown.