

Polaris RZR 1000/Turbo Seat Installation Guide

Fitment: 2014+ RZR 1000/Turbo

APEX

suspension seats

DAYTONA

carbon edition
suspension seats

PARTS INCLUDED

- 4 - Square Tubes
- 8 - 5/16" -18 Nyloc nuts
- 8 - Carriage Bolts
- 8 - 5/16" Flat Washers
- 8 - 1/4" -20 Nuts
- Pull Tab hardware kit

Spacer Kit (Use on 2 Seat or back seat of 4 seat)

TO INSURE YOUR SAFETY AND THE SAFETY OF OTHERS AND AVOID PROPERTY DAMAGE OR LOSS, PLEASE PAY CLOSE ATTENTION TO ALL INSTRUCTIONS, WARNINGS, CAUTIONS AND NOTES REGARDING THE USE AND CARE OF THIS PRODUCT

STEP 1: Remove the stock driver seat and place face-down on a clean surface. Remove the plastic seat base using a T-25 Torx driver on four fasteners as indicated (Figure 1). Retain the four fasteners for later use. Note: You will need to activate the slider lever to disengage the plastic base from the slider.

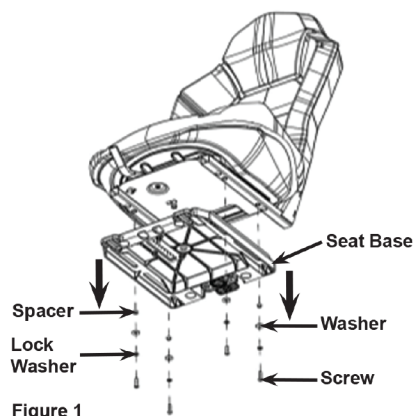

STEP 2: Remove the four fasteners attaching the slider plate assembly using the same T-25 torx from the stock seat.

STEP 3: Mount the included square tubes facing up to the plastic seat base using the included 1/4" -20 nylock nuts, t-25 torx, and the small spacer from the stock seat. Make sure the taller square tube is directed to the front of the seat. (Figure 2)



Figure 2



Figure 3

STEP 4: Mount the slider plate to the square tubes using the T-25 Torx from the stock seats. Note: Do not use an impact gun for this step. (Figure 3)

Step 5: Mount the square tubes with the plastic base to your new seats. On 2 seat and rear seats of 4 seat models you need to use the included spacer kit. Mount the seat using the carriage bolts and nylock nuts using a 1/2 inch wrench with the nut side facing down. Note: Driver side you will want to mount the plastic base dead center with the slotted holes on the bottom of the seat. For the passenger the seat needs to be mounted slightly outside of the slotted holes. (Figure 4)



Figure 4

STEP 6: Mount the pull tab to the release on the back of the seat using the included pull tab hardware