

WARNING: YOU ARE RESPONSIBLE FOR FIREARM SAFETY! AS A GUN OWNER, YOU MUST ACCEPT A SET OF DEMANDING RESPONSIBILITIES. AT ALL TIMES YOU MUST HANDLE YOUR RIFLE WITH RESPECT FOR ITS POTENTIAL DANGERS. THE INFORMATION CONTAINED IN THIS MANUAL IS CRITICAL FOR THE PROPER USE AND CARE OF YOUR CVA RIFLE. DO NOT ATTEMPT TO LOAD OR FIRE YOUR GUN UNTIL YOU READ AND THOROUGHLY UNDERSTAND THIS INFORMATION.

We at CVA would like to thank you for purchasing our product. You have our assurance that the CVA gun you have chosen has been manufactured to exacting tolerances and has passed rigid quality control standards before being shipped on to you, our customer. You must remember, however, that no amount of engineering, precision manufacturing, or safety inspections can replace the common sense and safe gun handling habits for which you are solely responsible. Some portions of this pamphlet are printed in RED in order to emphasize their special importance. However, this should in no way lessen the importance of the rest of this pamphlet. Even the smallest and most innocent safety violations can result in tragic loss.

THE SAFETY MECHANISM ON YOUR FIREARM IS A MECHANICAL DEVICE. LIKE ALL MECHANICAL DEVICES THE POSSIBILITY OF FAILURE IS ALWAYS PRESENT. YOU, AND ONLY YOU, ARE RESPONSIBLE FOR SAFELY CONTROLLING THE MUZZLE OF YOUR GUN. NO MECHANICAL SAFETY SHOULD EVER BE RELIED UPON TO TAKE THE PLACE OF SAFE GUN HANDLING! MAKE SURE THAT THE MUZZLE OF YOUR GUN IS ALWAYS POINTING IN A SAFE DIRECTION.

THE TEN COMMANDMENTS OF FIREARM SAFETY

1. Always keep the gun’s muzzle pointed in a safe direction.
2. Be sure of your target and what is beyond it.
3. Never rely on a gun’s mechanical “safety”. Keep your finger off the trigger and out of the trigger guard until you are ready to fire.
4. The gun should remain unloaded until ready to use.
5. Always wear hearing and eye protection.
6. Make sure that the barrel is clear of all obstructions before loading and shooting.
7. Handle every gun as if it were loaded.
8. Store guns and ammo separate and in a locked area.
9. Avoid alcoholic beverages and drugs before and during the use of a firearm.
10. Never bring a loaded firearm into a building or transport a loaded firearm in a vehicle of any kind.

1

GETTING STARTED

Your CVA Wolf or Optima is a break-action muzzleloader. The barrel and receiver are joined by a pin that makes the assembly, in effect, a pivoting hinge. By pulling the breeching lever, located in front of the trigger guard, to the rear the barrel will pivot, or “break”, open revealing the breechplug. This design makes your rifle easy to load, prime and clean. All controls are ambidextrous making your CVA rifle ideal for both right and left handed shooters. Your CVA rifle utilizes a 209 shotgun shell primer to ignite the powder charge. It is fully magnum capable. This means that you can use the “magnum” charge of 150 grains equivalent of pelletized blackpowder substitutes. This “magnum” load must never be used in side hammer guns or in any inline that is not specifically approved for this heavy load.

After fully reading this pamphlet:

1. Remove the rifle and related tools from the box.
2. Safety First! Pull the breeching lever in front of the trigger guard to the rear until the action unlocks. Pivot the barrel forward to open the breech and expose the breechplug. Remove the breechplug by turning counterclockwise by hand until it comes out. Verify the rifle is unloaded by looking through the barrel. If you cannot see light through the barrel you must assume it is loaded. Use the extended ramrod to push the load or obstruction out of the barrel.
3. Check the mechanical functions of the rifle by manipulating the breeching lever, the hammer and the trigger.
4. Clean the shipping grease from the inside of the barrel.
5. Apply CVA Breechplug Grease or high temperature anti-seize compound to the breechplug threads and replace it in the barrel. Tighten hand-tight only. Over tightening the breechplug can cause it to stick.
6. Make sure you understand all aspects of this pamphlet. **Get all questions and doubts answered prior to loading or firing.**
7. Protect your eyes and ears. Always wear adequate eye and hearing protection.

FOR YOUR SAFETY AND THE SAFETY OF OTHERS

CVA encourages you to take a certified hunter’s safety course before using this rifle or any other firearm. Consult the Game and Fish authorities in your area or your local sporting goods dealer for information on courses available. Even if you do not intend to hunt game animals, the information and training gained from taking a hunter’s safety course can help in preventing dangerous or fatal accidents from happening. Discharging firearms in a poorly ventilated area and / or handling ammunition may cause exposure to lead or lead compounds. According to the state of California, exposure to lead or lead compounds may cause cancer, birth defects or other reproductive harm. Make sure that you have proper ventilation at all times. Be sure to wash your hands thoroughly after shooting, handling ammunition, or cleaning your firearms. Do not eat or smoke during these activities.

5

SAFETY CONSIDERATIONS FOR MUZZLELOADERS

CAREFULLY READ THIS SECTION, AS THESE SAFETY CONCERNS ARE APPLICABLE TO MUZZLELOADERS AND, IN SOME INSTANCES, CENTERFIRE GUNS AS WELL. If you have questions, doubts, or concerns, please call CVA Customer Service at 770-449-4687.

1. Never smoke when shooting or handling a firearm or related equipment. Ashes and/or loose sparks may cause powder or caps/primers to ignite, resulting in personal injury or death.
2. Always wear eye protection. Flying debris from the breech area and muzzle are common with any firearm.
3. Never pour powder into a muzzleloader directly from a powder can, flask, horn, or any other large volume, enclosed container. Hot ember or sparks in the barrel can cause a flash that, in turn, may cause the container to explode.
4. All powder storage containers and primers/caps should be kept well away from the shooting area. Sparks from shooting could cause accidental ignition of these materials. Follow manufacturer’s instructions regarding long-term storage of these products.
5. Use only blackpowder or approved blackpowder substitutes in your muzzleloading firearms. If you have any questions regarding approved blackpowder substitutes call, write or e-mail CVA Customer Service.
6. **NEVER USE MODERN SMOKELESS POWDER IN ANY MUZZLELOADER.** The use of any amount of smokeless powder in a muzzleloader, by itself or in mixture with blackpowder or approved substitutes, will create dangerously high pressures which may, upon ignition, result in severe injury or death to the shooter or bystanders.
7. Always check to make sure your firearm is in good working order before use. Test the hammer, trigger, and breech carefully prior to loading. Check the barrel for obstructions, as any obstruction can cause the barrel to burst causing severe injury or death.
8. Use only the recommended loading data published specifically for your muzzleloader. Other models of muzzleloaders may have different powder charge and/or bullet requirements and limitations. Improper loading or overloading of a muzzleloader can result in severe injury or death.
9. Never prime or cap a muzzleloader, or load a centerfire gun until you are ready to fire. The primer/cap/cartridge should always be removed when walking, climbing trees or fences, transferring the gun from one person to another, leaving the gun unattended, etc.

2

BASIC MUZZLELOADING NEEDS

LOADING ACCESSORIES

- Blackpowder or an approved blackpowder substitute - **NEVER use any amount of modern smokeless powder in any muzzleloader.**
- Projectiles- PowerBelt™, sabot bullets, or conical bullets
- Ignition Source- Modern 209 primers made for muzzleloaders or shotshells
- Powder Flask- For carrying a supply of loose powder (not required for pelletized powder)
- Bullet Starter- To start the bullet into the bore
- Range Rod - To make loading at the range more convenient. Also used for cleaning.
- Speed Loaders- A convenient way to carry extra pre-measured powder charges and bullets for field loading.
- Safety Equipment- Good quality safety glasses and hearing protection.

CLEANING ACCESSORIES

CVA’s Barrel Blaster™ line of cleaning solvents and accessories is highly recommended. Refer to your CVA catalog or visit www.cva.com for details.

Barrel Brush - To loosen and remove hard deposits and fouling.

Cleaning Solvent - For easy cleaning of the bore and external metal surfaces.

Patches - Both dry and solvent-soaked for swabbing the bore, wiping the external surfaces and drying the rifle.

Jag - To retain the patch on the cleaning rod or range rod. A jag is permanently attached to one end of the under barrel ramrod.

CVA Barrel Blaster™ Rust Prevent Patches - For final protection of the bore. Rust Prevent Patches are also good for wiping the external metal surfaces to prevent rust and corrosion.

PROPELLANTS

NEVER, UNDER ANY CIRCUMSTANCES, USE ANY AMOUNT OF MODERN SMOKELESS POWDER IN ANY MUZZLELOADING RIFLE! The use of smokeless powder in your muzzleloader will create dangerously high pressures upon ignition which will likely lead to severe injury or death to the shooter and bystanders. The use of smokeless powder will immediately void the warranty.

BLACKPOWDER - Important! The term “blackpowder” refers to the formulation of the propellant, not the color. Most of the smokeless powders used in modern cartridge ammunition are also black in color but will cause dangerously high pressures. Blackpowder is available in several granulations which are rated according to the average size of each particle of powder. **ONLY USE BLACKPOWDER RATED AS “FFG” IN YOUR CVA BREAK ACTION RIFLE.** The use of other granulations may result in improper burning or higher pressures. The use of genuine blackpowder is less common today due to tight regulations regarding its storage and transportation.

6

10. Never lean a loaded firearm against a wall, tree, vehicle, or other surface. Any fall of a loaded gun may result in an accidental firing of the gun, which may result in severe injury or death.

11. Never transport a loaded firearm in any type of vehicle. A muzzleloader is considered loaded until powder, bullet, and primer/cap have been removed. A centerfire is considered loaded until the cartridge is removed.

12. Never give, or accept from anyone else, a loaded muzzleloader. Only the party who loaded, or witnessed the loading of, the muzzleloader should fire it. This practice will help prevent dangerous double-loading which, when fired, may result in severe injury or death.

13. Never store a loaded firearm. The cartridge, or the bullet, powder, and primer/cap should be removed and the gun cleaned prior to any storage.

14. Never load a firearm without first making sure the barrel is unloaded and unobstructed.

15. Use extreme caution when hunting from a tree stand. The accidental dropping of a firearm may cause a discharge, which could result in severe injury or death. Be sure the firearm is unloaded before raising or lowering the firearm.

16. Never rely upon a mechanical safety! Firearms should always be handled as if ready to fire, regardless of the position or condition of the mechanical safety.

17. Always use proper cleaning procedures. Firing of an improperly maintained or corroded firearm may lead to unsafe pressure conditions and/or cause the barrel to rupture resulting in severe injury or death.

18. Make sure the projectile is fully seated on the powder charge in a muzzleloader. The firing of a “short start,” or improperly seated bullet, may cause the barrel to burst resulting in severe injury or death.

19. Always keep the barrel pointed in a safe direction when loading. Never allow the barrel to point at anything that you do not wish to shoot.

3

BLACKPOWDER SUBSTITUTES - Safer and cleaner-burning substitutes for blackpowder have been developed and these are perfectly suitable for use in your CVA muzzleloader. Some of these are available in both granular and pelletized form. An important thing to remember is that individual rifles will perform differently with the same powder and bullet combinations. Each of the blackpowder substitutes have their own characteristics and CVA recommends that you try several powder and bullet combinations to see which one gives you the performance you are looking for. Please refer to the manufacturer’s written instructions for the specific propellant you are using. If you have technical questions regarding the propellant you are using, please contact the manufacturer’s customer service or technical department listed on the product label.

PROJECTILES

POWERBELT™ BULLETS - PowerBelt™ Bullets are conical bullets with a patented plastic base designed to seal the bore and trap the propellant’s pressure. This provides consistent velocities and unsurpassed accuracy. Unlike sabots, however, the PowerBelt™ bullet is easy to load and leaves no plastic residue to foul the barrel. PowerBelt™ bullets are also full caliber diameter to deliver the maximum energy possible out of a muzzleloader. All weights of PowerBelt™ bullets can be used in your CVA rifle. PowerBelt™ bullets are highly recommended for use in your CVA rifle.

SABOTED BULLETS - The sabot is a plastic sleeve that is utilized to hold a smaller-than-bore diameter bullet tightly in the bore. The rifling in the bore engages the plastic sabot rather than the bullet itself. Saboted bullets from several manufacturers have been tested and found to provide acceptable accuracy in CVA muzzleloaders when used in accordance with the manufacturer’s instructions. However, most sabots leave a heavy plastic residue in the bore requiring cleaning of the bore after every shot. This plastic residue along with the extremely tight fit of most sabots makes loading for quick follow-up shots very difficult. **The CVA Slick Load™ Sabot** is specifically designed to overcome the loading and fouling difficulties associated with conventional sabots and is highly recommended for those shooters that prefer saboted projectiles. Do not use saboted bullets weighing over 300 grains in your CVA rifle.

LEAD CONICALS - The lead conical is one of the oldest designs for muzzleloading guns. These bullets are typically heavy in weight and feature a hollow base that expands with pressure to seal the bore. Although lacking in some modern features they remain effective on short to medium range shots and are ideal for use in states that do not allow projectiles with plastic parts. Do not use lead conical bullets weighing over 400 grains in your CVA rifle.

PRIMERS - The number 209 shotgun primer has become the most common ignition source for inline muzzleloaders. This popularity has prompted several manufacturers to develop 209 primers specifically for the muzzleloading market. Choosing one of these specialty primers can result in better accuracy and a cleaner shooting barrel.

7

The CVA Wolf or Optima muzzleloader you have purchased is one of the most advanced and easy to use rifles in the muzzleloading market. This pamphlet will teach you the basics of how to operate your rifle in a safe and efficient manner. Certain sections of this pamphlet are written in **RED** to stress their importance in respect to safety. Be sure you also read the safety instructions completely before loading your gun. If you sell, trade or give this rifle to any other person, please make sure a copy of this pamphlet accompanies the rifle. Replacement pamphlets are available from CVA Customer Service. You can contact CVA Customer Service by mail, telephone or e-mail.

BLACK POWDER PRODUCTS, INC
ATTN: CUSTOMER SERVICE DEPT.
1685 BOGGS ROAD • SUITE 300
DULUTH, GA 30096
770-449-4687 (8:30 TO 4:00 EST)
info@bpiguns.com

THE INFORMATION CONTAINED IN THIS PAMPHLET IS CRITICAL FOR THE PROPER USE AND CARE OF YOUR RIFLE. DO NOT ATTEMPT TO LOAD OR FIRE YOUR RIFLE UNTIL YOU HAVE READ THIS MANUAL IN ITS ENTIRITY. FAILURE TO DO SO MAY RESULT IN ACCIDENTS THAT CAN CAUSE SERIOUS INJURY OR DEATH TO THE SHOOTER OR BY STANDERS.

FOR ADDITIONAL INSTRUCTIONS ON MUZZLELOADING PLEASE VISIT OUR WEB SITE AT www.cva.com AND CLICK ON MUZZLELOADER BASICS. THIS ON-LINE INSTRUCTION VIDEO SUPLEMETS THIS MANUAL AND INSURES THAT YOUR MUZZLELOADING EXPERIENCE IS SAFE AND ENJOYABLE.

Your CVA rifle has unique features that you must become familiar with. These features are illustrated in the drawing below. Please take time to become familiar with your rifle and to learn to properly manipulate the breeching level, hammer and trigger functions before attempting to load or fire your rifle.

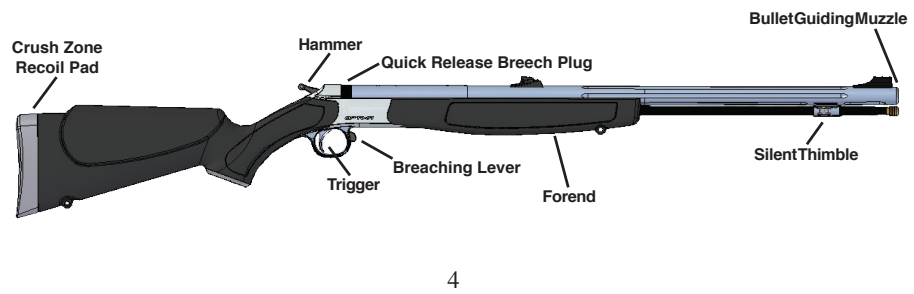

4

WHAT IS THE BEST BULLET AND POWDER COMBINATION FOR MY GUN?

Several blackpowder substitutes are available on the market. Each has different properties, advantages and disadvantages. You may want to try several to find the best one for you based on your individual needs. However, after extensive and long-term testing, CVA has found that, in terms of accuracy, cleanliness, and ease of use, IMR® White Hots® is the best performing and most highly recommended propellant for use in CVA muzzleloaders. Use in conjunction with PowerBelt™ Bullets or CVA Slick Load™ Sabots for absolute best results.

MINIMUM AND MAXIMUM LOADS

CVA recommends a minimum of 50 grains, by volume, of blackpowder or blackpowder substitute in your .45 or .50 caliber muzzleloader. The maximum load in CVA break-action guns, and any other CVA in-line rifle designated as a “Magnum” is 150 grains by volume. This maximum load is generally known as the “magnum” load and is best suited for pelletized powder due to the more efficient burning characteristics of the powder pellets. Magnum loads of loose powder may be shot but are not recommended because of their inefficient and incomplete burning of the powder. Some bullet designs depend on the thrust of the powder charge to expand, or obdurate, the bullet inside the bore for best accuracy. Loads under 50 grains cannot be depended on to do this. In many cases lighter bullets are more sensitive to this than heavier bullets and often require heavy powder charges to produce the best accuracy. For those who wish to shoot moderate powder charges of 90 to 120 grains the heavier bullets generally give better results.

LOADING YOUR CVA RIFLE

Before loading you must make sure that the barrel is unloaded and free of obstructions. The best way is to remove the breechplug and look through the barrel. If you cannot see light through the barrel there is a load or other obstruction that must be removed. Use the ramrod to push the load or obstruction out of the barrel. If your rifle has not been shot since the last cleaning, it is recommended that you fire at least 2 primers without a load in the barrel. This assures that the breech is clear and dry. If you are using loose powder, also called granulated powder, carefully pour the powder into a powder measure that is set for the amount of powder you wish to use. Pour the powder from the measure into the barrel. **Never pour powder directly from a can or flask into the barrel.** It is possible for a small spark or ember in the barrel to ignite the new powder as it is poured into the barrel causing the can or flask to explode. If you are using pelletized powder, also referred to in some brands as powder sticks, drop the required number into the barrel. Read the manufacturer’s instructions to see if your brand requires one end to be inserted first.

After loading the powder you must load and seat the bullet. Your CVA features a Bullet Guiding Muzzle™. This is a short unrifled section at the muzzle that allows easy insertion of the bullet into the bore. Press the bullet into this section with your

8

thumb. Use a bullet starter to push the bullet into the rifling. Insert the ramrod or range rod into the barrel and push the bullet down the barrel until firmly seated on the powder charge. It is recommended that you place some kind of a mark on the rod that is even with the muzzle. This can be used as a reference point anytime this same load is used to be certain the bullet is fully seated in the barrel. After loading the powder and bullet, pull the breeching lever to the rear to open the action. Place a number 209 primer into the breechplug and close the action with a firm “snap”. You are now ready to shoot.

SHOOTING YOUR CVA RIFLE

Always judge your target carefully. Know what is beyond the target in case of a miss or full penetration. You should always place the target in front of a backstop of dirt or heavy timbers when target shooting. When hunting, be sure of what is beyond the target. Do not shoot if your bullet may enter a camp, cross a road, or head toward a house or building. With the muzzle pointed in a safe direction, pull the hammer back until it stops. Carefully aim the rifle at the intended target and pull the trigger. When reloading it is recommended that you swab the bore between shots with a slightly damp patch. This will remove the bulk of the fouling from the last shot, making your loading more consistent and improving accuracy. It also helps to assure that there is no remaining ember or hot spot that may ignite the next powder charge prematurely.

HAMMER SPUR

CVA rifles come with a reversible hammer spur. Please note that the hammer spur is attached with left-hand threads. Turn the hammer spur in a clockwise direction to remove it. Once you decide which side of the hammer you prefer, clean the threads and use a low grade thread sealant or a small drop of household white glue to secure it in position.

CLEANING YOUR CVA RIFLE

Due to the corrosive nature of muzzleloading powders you must make cleaning a top priority as soon after shooting as possible. Neglecting this responsibility will certainly result in a ruined barrel. An important thing to remember is that proper cleaning is just as important for stainless steel guns. Although stainless steel guns are more resistant to rust and corrosion for a short time, they will rust and corrode nearly as badly as blued steel in the long run.

CLEANING PROCEEDURE

1. Using a properly fitting screwdriver, remove the screw from the center of the forend. Gently pull the forend off of the barrel.
2. Pull the breeching lever to the rear and open the action. Without the forend in place the barrel will pivot forward and off of the action.
3. Turn the breechplug in a counter-clockwise direction and remove. Wet the breechplug thoroughly with cleaning solvent and set aside.
4. Using a jag on a cleaning rod, range rod, or extended ram rod, push a patch or two wet with water through the barrel to remove the bulk of the fouling from the bore.

9

5. Place a properly fitting bore brush on the rod and make several full-length strokes through the barrel. The brush should be wet with solvent for this step.
6. Remove the brush from the rod and use the jag to push several patches damp with solvent through the bore. Allow the solvent to work for a minute or two and follow with dry, clean patches. Repeat until the barrel is clean. Use a good quality non-petroleum gun oil to protect the bore. CVA Barrel Blaster Rust Prevent Patches are excellent for this.
7. Take the solvent-soaked breechplug and wipe all surfaces, including the threads, with patches or a rag. Make sure the front is clean as well as the primer pocket and flash hole (the small hole through the center of the plug). Cotton swabs, pipe cleaners and a nipple pick are appropriate here. Generously apply breechplug grease or high temperature anti-seize to the breechplug threads and install into the barrel finger tight (over tightening the breechplug can lead to a breechplug that is difficult or impossible to remove).
8. Use a patch wet with solvent to scrub the breechface and other action areas that you can reach. Cotton swabs can be used here to do a good job. Wipe dry with a clean patch or rag and apply rust preventative.
9. Using a properly fitting screwdriver remove the firing pin bushing from the front of the breechface. The firing pin and spring will drop out. Clean these parts and the firing pin recess thoroughly, lube and reinstall. Cotton swabs are good to use here as well. A light coating of breechplug grease on the bushing threads is a good idea.

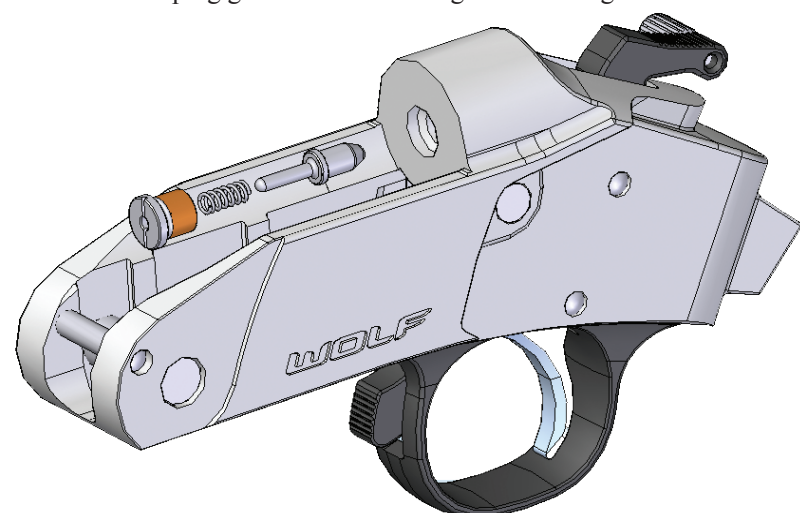

10. Reassemble the gun and check all mechanical functions. Wipe the entire gun with a rust preventative.
11. Failure to properly maintain your rifle can cause damage to the bore and outside surfaces of the rifle. It can also cause your breechplug to become stuck in place. If this happens pad a pair of pliers with a rag, leather or heavy cardboard to assist in removal. If this does not work, please send the barrel to CVA for proper removal.

10

SIGHT ADJUSTING AND SCOPE MOUNTING

Some models come from the factory equipped with fiber-optic open sights. To adjust the sights to the bullet's point of impact you should fire at least 2 shots at the target before making adjustments. Adjust your sights to the center of the group. The “rule of thumb” to remember is that you move the rear sight the same direction that your bullet hit must move. In other words, if you need your group to go to the right, move the rear sight to the right. If you need your group to go up, move the rear sight up. Your rifle is drilled and tapped for a scope mount. A telescopic scope can assist in accurate bullet placement during target shooting and hunting (in areas where legal, check your state's regulations). Carefully check the fit of the selected scope base to your barrel. Although the base you select may have come with instructions for installation, please also read the recommendations below. CVA uses and highly recommends DuraSight scope mounts and rings for use with your CVA rifle.

1. Examine the scope mount holes in the barrel. Each hole should have full, sharp threads. Remove any filler screws or other matter from the holes. Clean the threads with a light solvent such as alcohol.
2. Examine each of the mounting screws. Look for bent or broken threads. Check each screw in a hole to insure that the screw threads easily into place. Clean the threads with a light solvent.
3. Thread locking compounds such as Loctite™ are not necessary. If you desire to use a thread locking product use as little as possible. The best way to use is to apply a small bit to the first 2 or 3 threads of the screw. Placing compound directly into the screw hole nearly always results in the compound being forced out and under the base, resulting in uneven contact between the base and barrel and possible accuracy problems.
4. Place the base onto the barrel and fully tighten one screw. Check to see if the base is held tightly to the barrel. If it is, loosen the screw and install another. Check each screw individually in this manner to make sure that each screw is doing its job. If you find a screw that is not securing the base on its own, investigate the cause and correct before moving on.
5. When all screws have been tested, secure the base by tightening all screws evenly. Rule of thumb - if your fingers hurt or the torx wrench is bending you are too tight.
6. Carefully mount the rings to the scope following the manufacturer's recommendations.

11

In many cases you must remove the rear sight when installing the scope. This can be avoided if desired by using a scope mounting system of the “see through” design. However, for best results, the scope should be mounted as low to the barrel as possible.

REPAIR AND SERVICE

In the case that your CVA rifle needs repair or service we recommend that you return it to our facility. This will assure that your rifle is worked on by trained, qualified gunsmiths. Pack your rifle carefully and send postage-paid to:

BLACK POWDER PRODUCTS, INC
ATTN: REPAIR DEPARTMENT
1685 BOGGS ROAD • SUITE 300
DULUTH, GA 30096

There is a form available on line at www.cva.com that will assist you in having your service or repair done correctly and in a timely manner. If you do not use this form please be sure to include a note describing the problem or service desired along with your name and return address.

Many times small problems and concerns can be addressed with CVA Customer Service and taken care of without the need to send the rifle back.

Most parts are available through CVA Customer Service at a reasonable cost. However, some internal parts must be fitted by our gunsmith and are only available as an installed part.

LIMITED LIFETIME WARRANTY

CVA warrants all factory-finished firearms to be free of defects in workmanship or materials for the lifetime of the firearm. This Limited Lifetime Warranty only applies to the original consumer owner. This warranty is put into effect by the return of the authorized warranty card within 15 days of purchase and is not transferable. To save time and postage, the warranty information may also be transmitted electronically via our web site at <http://www.cva.com>.

Any covered CVA firearm or part thereof that is returned postage paid to the Repair Center will be repaired or replaced to our commercial standard, free of charge, and returned to the consumer postage prepaid. This warranty does not cover damage to any structures, buildings, vehicles, persons or animals, or any other damage resulting from careless handling, improper loading, rust or corrosion, neglect, improper maintenance or customer alterations.

CVA reserves the right to refuse to repair or replace any firearm or parts thereof damaged by any of the above. The warranty does not cover normal wear of any part, metal or stock finish, cost of inconvenience due to product failure, or transportation to the Repair Center.

PLEASE VERIFY THAT THE GUN IS UNLOADED BEFORE SHIPPING! If your gun is loaded and you don't know what to do please call CVA Customer Service for instructions. It is not only unsafe and irresponsible to ship a loaded gun, *it is a criminal offense that must be reported.*

12



BLACKPOWDER PRODUCTS, INC
1685 BOGGS ROAD • SUITE 300
DULUTH, GA 30096
www.cva.com

FORM 103B • REV. 10/10

America's #1 Muzzleloader



OWNER'S INSTRUCTION AND SAFETY MANUAL FOR OPTIMA/WOLF

THIS PAMPHLET CONTAINS INFORMATION CRITICAL TO THE SAFE USE AND MAINTENANCE OF CVA FIREARMS. YOU MUST READ THIS MATERIAL ENTIRELY AND FULLY UNDERSTAND THIS INFORMATION BEFORE YOU CAN SAFELY USE YOUR FIREARM. IF FIREARM IS LOANED OR SOLD BY A DEALER OR INDIVIDUAL, THIS BOOK MUST ACCOMPANY THE FIREARM. REPLACEMENT BOOKS ARE AVAILABLE FROM OUR FACTORY. CALL CVA CUSTOMER SERVICE AT (770) 449-4687 IF YOU HAVE ANY QUESTIONS.

Watch the MUZZLELOADING BASICS video at CVA.com

This warranty gives you certain specific legal rights. You may also have other rights, which vary from state to state. This warranty is void if:

- Any propellant other than the correct type of blackpowder or blackpowder substitute is used.
- Unauthorized repair work or disassembly of the receiver has been performed by the owner or a third party.
- CVA recommended maximum powder charge or bullet weight has been exceeded.
- Any form of plastic patch has been used (sabots and PowerBelts™ not included).
- Gun is returned in an abused or neglected condition (rusty, corroded, etc.).

VOLUNTARY RECALL INFORMATION

In August of 1997, CVA implemented a Voluntary Recall of all in-line muzzleloading rifle models with serial numbers ending in -95 or -96.

Example of a recalled serial number: 61-13-xxxxxx-95

If you, or someone you know, have a CVA in-line rifle with such a serial number, do not use or allow anyone else to use the gun under any circumstances. Call CVA immediately at 770-449-4687 for complete details and instructions on how to receive a replacement gun.

In May of 1999, Blackpowder Products, Inc. purchased the assets of Connecticut Valley Arms, Inc. and now operates under the trade name of CVA. Any claims relating to the above-described Voluntary Recall should be addressed to Connecticut Valley Arms, Inc., not to Blackpowder Products, Inc. Blackpowder Products, Inc. assumes no liability for any products manufactured or sold prior to January 1, 1998.