



EMMA 3.0 Owner's Manual



<https://roll-road.com>

Take down your serial numbers here!

Bike frame number:

Battery serial number:

Motor serial number:

**If you reset a security password via Display Setting,
we suggest you write it down here in case
you may forget:**

Note: Please consult our customer service for power-on and display setup passwords.

Contents

◆ About Manual.....	2
◆ Basic Specifications.....	3
◆ Battery Pack Installation.....	4
◆ Color LCD Display Manual.....	5
◆ Safety Checklist.....	22
◆ Emma Use&Care.....	25
◆ Trouble Shooting.....	33
◆ Quality Assurance and After-Sale Service	34
◆ Maintenance.....	37
◆ Riding Limitations.....	39
◆ Online Resources.....	40

◆ About Manual

This manual contains details of the product, information on its operation and maintenance, and other helpful tips for owners. Read it carefully and familiarize yourself with the Roll Road Emma 3.0 before using it to ensure safe use, reduce risk of damage and premature wear, and prevent accidents. Be sure to retain this manual as your convenient Roll Road e-Bike information source.

This manual contains many Warnings and Cautions concerning safe operation, and consequences if proper setup, operation and maintenance guidelines are not followed. All information in this manual should be carefully reviewed.



The safety grade color of Caution is orange, and if not avoided, may result in moderate or serious injury.



Users should also pay special attention to information marked in this manual beginning with “**NOTICE**”.



The safety grade color of Warning is red, and if not avoided will likely result in serious injury or death.

Because it is impossible to anticipate every situation or condition which can occur while riding, this manual makes no representations about the safe use of our bicycles under all conditions. There are risks associated with the use of any bicycle which cannot be predicted or avoided, and which are the sole responsibility of the rider. You should keep this manual, along with any other documents that were included with your bicycle, for future reference, however all content in this manual is subject to change or withdrawal without notice. Visit <http://roll-road.com/> to download the latest version. Assembly and first adjustment of your Roll Road e-Bike requires special tools and skills, and it is recommended that this be performed by a trained bicycle mechanic if possible.

◆ Basic Specifications

Motor	Bafang Sutto 1500W	Rear Rack	Wide and Light Aluminum
Frame	6061 Aluminum Alloy	Speed Sensor	Torque Sensor (1-5 pedal assist levels)
Drive Mode	Half Twist Throttle +Pedal Assist	Weight	132lb /84lb (W/O Battery)
Display	4" Color LCD Display	Pedals	Wellgo
Battery	Dual 52V 20Ah Lithium Battery with USB Port	Fender	Full Fenders
Front Fork & Rear Air Shocks	Soft and hard Adjustable Lockout & Hydraulic Suspension	Lights	1200 Lumen LED Headlight & Front and Rear Turning Signals & Integrated Taillight
Color	Black	Crank Set	Front: 52T Rear: 16T
Tire	CST Scout 20"×4" In	Length*Width*Height	67*29*43.3 In
Speed System	Single-Speed	Cruise Control	Added
Brake	180mm Hydraulic Disc Brakes	Payload Capacity	450 LB
Chain	SUMC	Charger	Fast 3A with a Cooling Fan Inside
RIM	Aluminum Alloy Spoke Rim	Charging Time	6-8 Hours
Class	Class 2 by Default	Drive System	Pure Throttle; Pure Pedal Assist; Both

◆ Battery Pack Installation Guide



1. After putting the battery into the slot correctly, push it downward into the lock, then push the battery into the frame and lock it.
2. Notice: the key must be pulled out (Otherwise the key may be crushed when turning the fork).

NOTICE: Before assembling your bike, it's recommended to remove the battery for the reasons outlined below:

1. Determine if there's battery drain or damage during shipping.
2. Reduce the weight of the e-bike to make it easier to maneuver the bike while assembling.
3. Avoid battery damage during the assembly process.

Emma LCD Display User's Manual



Contents

I . Safety Notes

II . Overview

1. Product Name and Model
2. Product Introduction
3. Specifications
4. Function
5. Size
6. Assembly
7. Serial Code

III. Operation

1. Display Interface

- 1.1 Riding Interface
- 1.2 Setting Interface
- 1.3 Error Interface

2. Key Pad

3. Key Operation

- 3.1 On/Off
- 3.2 Assist Level
- 3.3 Toggle Displays
- 3.4 Light On/Off

3.5 Walk Assist Mode

4. Settings

1. Error Code

2. Connection

IV. Version

I . Safety Notes

PLEASE TAKE CAUTION WHEN USE, DO NOT PLUG OR UNPLUG THE DISPLAY WHILE YOUR E-BIKE IS POWERED ON.

- AVOID CLASHES OR BUMPS TO THE DISPLAY.

- AVOID USING IN HEAVY RAINS, SNOWS OR LONG EXPOSURE TO STRONG SUNLIGHT. DO NOT TEAR THE WATER-PROOF FILM ON THE SURFACE OF THE SCREEN, OTHERWISE THE WATER-TIGHT PERFORMANCE OF THE PRODUCT MAYBE DEGRADED.

- DO NOT PLUG OR UNPLUG THE DISPLAY WHILE THE SYSTEM IS POWERED ON. UNAUTHORIZED ADJUSTMENT TO DEFAULT SETTINGS IS NOT SUGGESTED, OTHERWISE NORMAL USE OF YOUR E-BIKE CAN NOT BE GUARANTEED.

- WHEN THE DISPLAY PRODUCT DOES NOT WORK PROPERLY, PLEASE SENDTHE IT FOR AUTHORIZED REPAIR IN TIME.

II. Overview

1. Product Name and Model

Product Name: E-Bike Display Product Model: SW-M808X

2. Product Introduction

SW-M808X features high-brightness anti-glare color LCD and minimalist interface, working as an ideal HMI solution for Roll Road electric bikes.

3. Specifications

- Working Voltage: DC 24V/36V/48V/60V/72V
- Rated Working Current: 12mA
- Leakage current: <1uA
- Screen Size: 4.0"LCD
- Communication Type: UART (by default) / CAN (optional)
- Optional Functions: Bluetooth, NFC
- Working Temperature: -20°C ~ 70°C
- Storage Temperature: -30°C ~ 80°C
- Waterproof Rating: IP65

4. Function

- Boot password
- System unit switch (km/h or mph)
- Assist Level Control and Display
- Battery indication: battery level percentage, low voltage indication

-
- Speed display: (in km/h or mph)
real-time speed (SPEED), max speed (MAX), average speed (AVG)
 - Distance: single-trip distance (TRIP), total travel distance (ODO)
 - Assist Mode Control and Display (3/5/9 levels)
 - Walk assist mode
 - Front light indication: front light status supported by controller.
 - Error code indication
 - Riding Info: Braking Status, Front Light Status, Cruise, Low Voltage.
 - Turning Signals: This function works with controller.
 - Dual Drive Control and Display: This function works with controller.
 - Status of Double Battery Packs: optional, works with controller.
 - NFC Function: optional.
 - Bluetooth Connection: optional, support OTA upgrade via mobile phone.

5. Size

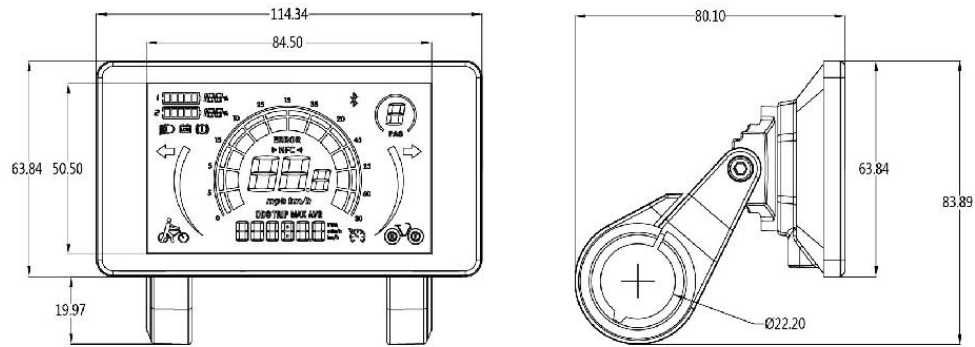

6. Assembly

① Open the holder ring/rubber spacer of the display and fix the display on the handlebar, adjust it to a proper facing angle. Use a M4 Hex Wrench to fix and tighten the screws. Standard fixing torque: **1N·m**.

***Damage due to excessive fixing torque is not covered by warranty.**

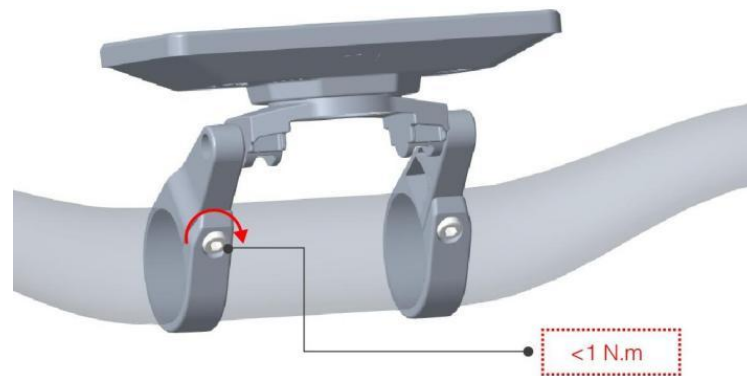

② Open the holder ring/rubber spacer of the keypad and fix it on the handlebar, adjust it to a proper facing angle. Use a M3 Hex Wrench to fix and tighten the screws. Standard fixing torque: **1N·m**.

***Damage due to excessive fixing torque is not covered by warranty.**

③ Plug the 5-pin connector of the display to the coupling connector of the Controller.

7. Serial Code

Example:

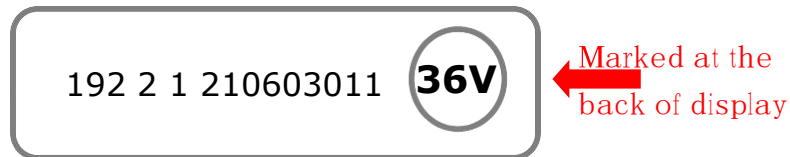

192: Customer Code

2: Protocol Code

1: Program can be overridden (0 means cannot be reprogrammed)

210603011: P.O. (purchase order number)

III. Operation

1. Display Interface

1.1 Riding Interface

- Status: Real-time Riding Status: Bluetooth, Front Light, Brake, LowVoltage, Turning, Cruise, Drive Status, etc.
- Battery Status: Residual Battery Percentage
- Multi-Function Section: ODO (total range), TRIP (single ride range), MAX (max. speed), AVG (average speed), TIME (riding time), VOL(battery voltage), Wh (motor power), CUR (current), etc.
- Assist Level Mode: 3/5/9 Levels available.

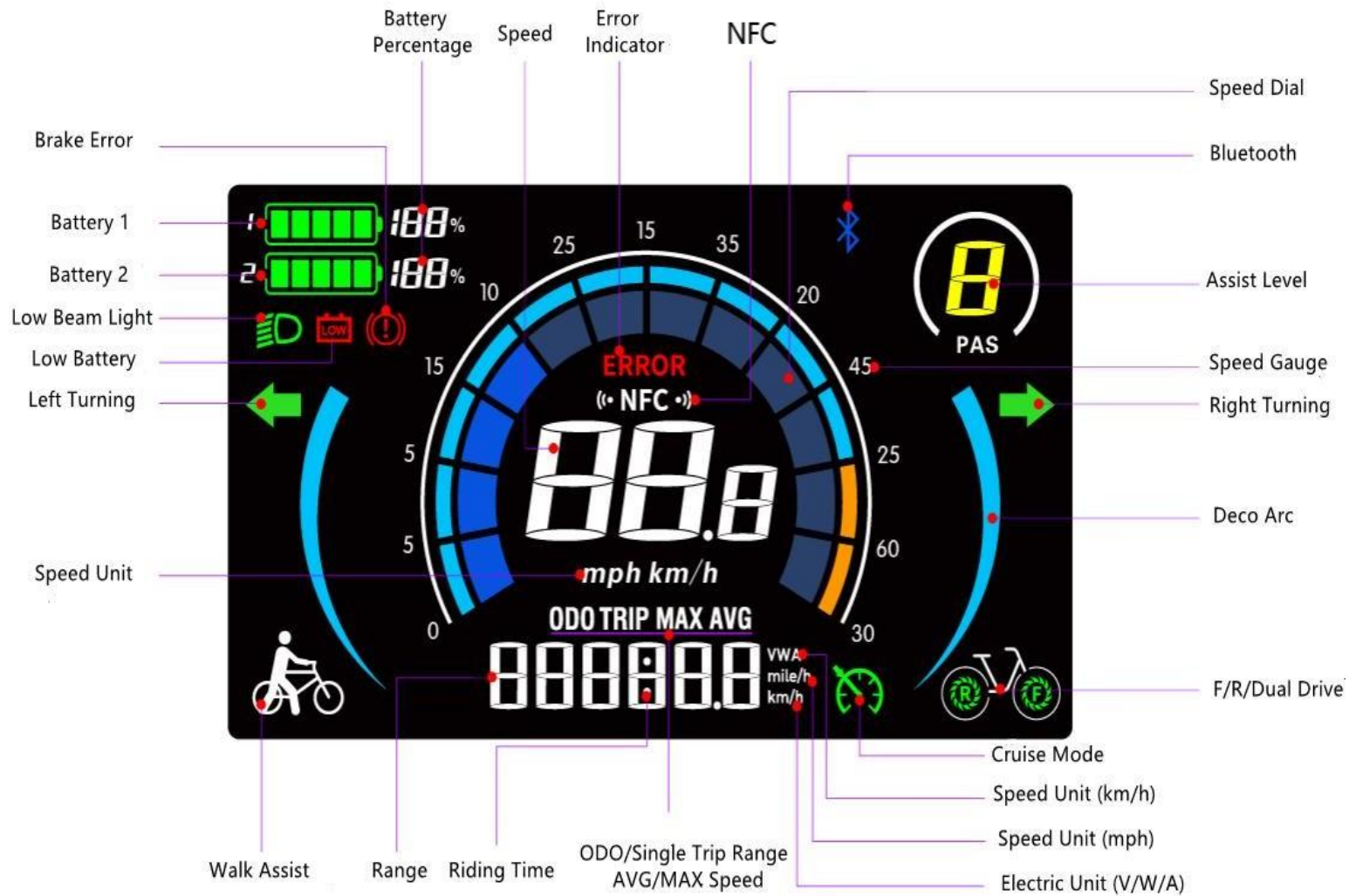

1.2 Setting Interface



In the above interface: Setting Item: P01, Parameter Value: 02

1.3 Error Interface

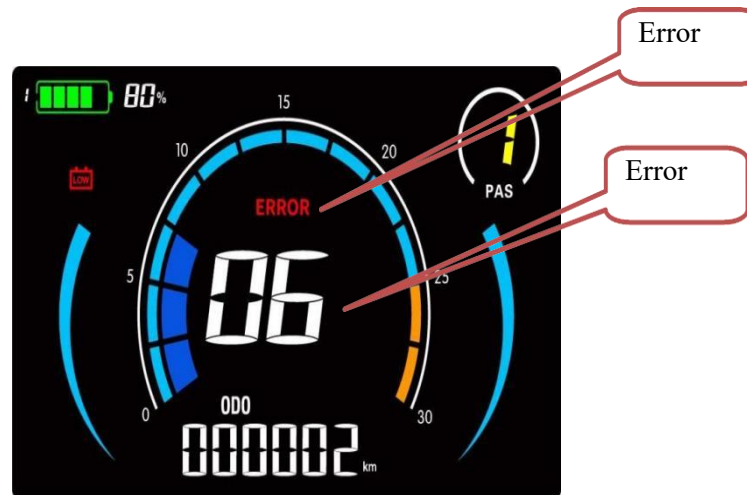

In the above interface: Error Indicator: ERROR, Error Code: 06

2. Key Pad

SWK2 Keypad Illustration:



There are 5 keys on the SWK2 keypad, in the following instructions: **+** is called Plus Key;

⏻ is called On/Off Key;

🚶 is called Minus/Walk Assist Key;

💡 is called Light Key;

i is called Info Key;

3. Key Operation

Key operation guide as follows:

Press and Hold: means press and hold the key(s) for more than 2s.

Press: means press the key(s) for less than 0.5s.

Double Tap: means double tap the key(s) within 0.3s

3.1 On/Off

Turn on the Display: When the display is off, press and hold the On/Off Key to turn on the display, it will show boot interface and then enter riding interface. (If boot password is activated, enter the boot password at start).

Turn off the Display: When the display is on, press and hold the On/Off Key, the display will be turned off. If no operation is engaged for 10min (0km/h), the display will be auto-off. Auto-off time can be set in the Settings.

3.2 Assist Level

Press the Plus Key or Minus/Walk Assist Key to switch assist levels. There are 5 levels by default: 0/1/2/3/4/5. 0 means no assist power.

3.3 Toggle Displays

When the display is on, press the Info Key to toggle among ODO (total range), Trip (single trip range), TIME (riding time) etc.

3.4 Light On/Off

Turn on the Front Light: when the front light is off, press the Light Key to turn it on, and the light icon will be shown on the riding interface (to remove this function, please reconfigure the controller).

Turn off the Front Light: when the front light is on, press the Light Key to turn it off, and the light icon will be off on the riding interface.

3.5 Walk Assist Mode

Engage Walk Assist Mode: On the riding interface, press and hold the Minus/Walk Assist Key to enter walk assist mode. Hold the Minus/Walk Assist Key to engage walk assist mode, the walk mode icon will be shown on the riding interface, the real-time speed will be shown in the speed section.

Disengage Walk Assist Mode: release the Minus/Walk Assist Key to disengage the walk assist mode, the icon will off on

the riding interface.

4. Settings

4.1 Setting Operations

① **Enter the Settings:** when the display is on, press and hold the Plus Key and the Minus/Walk Assist Key together to enter the Settings. Available setting items include: system voltage, wheel size (inch), magnetic steel number for speed gauge, speed limit etc (please refer to 4.2 Setting Items).

② **Adjust Settings:** on the Settings interface, press the Plus Key or the Minus/Walk Assist Key to set values for items. The value will blink after change. Press the On/Off Key to save the set value and switch to next item.

③ **Save and Exit Settings:** press and hold again the Plus Key and the Minus/Walk Assist Key together to exit the Settings and save the set value. The system will save and exit automatically if there's no operation for 10s.

4.2 Setting Items

- **P00: Factory Reset:** optional.
- **P01: Backlight Brightness.** 1: darkest; 3: brightest.
- **P02: System Unit.** 0: km (metric); 1: mile (imperial).
- **P03: System Voltage:** 24V/36V/48V/60V/72V.
- **P04: Auto-Off Time**
0: never, other value means auto-off time interval. Unit: minute
- **P05: Pedal Assist Level**
 - 0-3 Level Mode; 1-3 Level Mode (no Level0)
 - 0-5 Level Mode; 1-5 Level Mode (no Level0)
 - 0-9 Level Mode; 1-9 Level Mode (no level 0)
- **P06: Wheel Size.** Unit: inch; Increment: 0.1
- **P07: Motor Magnets Number for Speed Gauge.** Range: 1-100
- **P08: Speed Limit.** Range: 0-100km/, communications status (controller-controlled). The max speed will be kept constant at the set value.
Error Value: ± 1 km/h (applicable to both the PAS/throttle mode)

Note: The above-mentioned values are measured by metric unit (km/h). When the system unit is set to imperial unit

(mph), the speed displayed will be automatically switched to corresponding value in imperial unit, however the speed limit value in the imperial unit interface won't change accordingly.

■ **P09: Direct Start / Kick-to-Start**

- 0: Direct Start (Throttle-on-demand);
- 1: Kick-to-Start

■ **P10: Drive Mode Setting**

- 0: Pedal Assist – The pedal assist level decides the motor power output. In this status the throttle does not work.
- 1: Electric Drive – The e-bike is only controlled by the throttle. In this status the pedal assist does not work.
- 2: Pedal Assist + Electric Drive (electric drive does not work in direct-start status)

■ **P11: Pedal Assist Sensitivity.** Range: 1-24.

■ **P12: Pedal Assist Starting Intensity.** Range: 0-5.

■ **P13: Magnets Number in Pedal Assist Sensor.** 3 Types: 5/8/12pcs.

■ **P14: Current Limit Value.** By default: 12A. Range: 1-20A.

■ **P15: Display Low Voltage Value.**

■ **P16: ODO Clearance.** Press and hold the Plus key for 5s and ODO value will be cleared.

■ **P17: Cruise.** 0: cruise function deactivated, 1: cruise function activate.

5. Error Code

Error Code (decimal)	Status	Note
E00	Normal	
E01	Reserved	
E02	Brake Error	
E03	PAS Sensor Error (Riding Mark)	Not Realized
E04	Walk Assist Mode	
E05	Real-Time Cruise	
E06	Low Voltage Protection	
E07	Motor Error	
E08	Throttle Error	
E09	Controller Error	
E10	Communications Error	
E12	BMS Communications Error	
E13	Front Light Error	

6. Connection

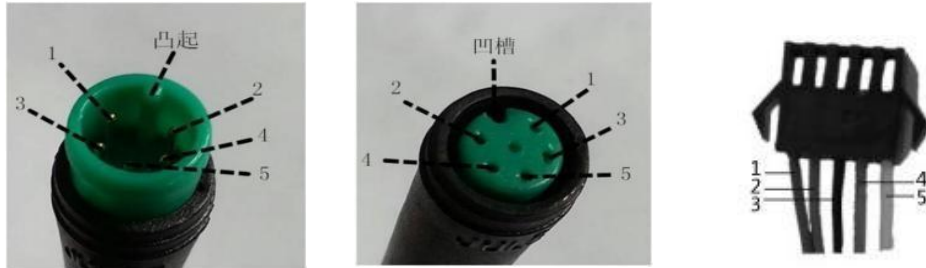

Display to Controller Controller to Display Controller Connector

Pin No.	Wire Color	Functions
1	Red (VCC)	Display Power Wire
2	Blue (K)	Electric Lock Wire
3	Black (GND)	Display Ground Wire
4	Green (RX)	Display Data Receiving Wire
5	Yellow (TX)	Display Data Sending Wire

Extended Functions- Front Light:

Brown (DD): The power wire (+) of the light White (GND): The ground wire (≐) of the light.

Note: For waterproof connectors, wire sequences are concealed.

IV. Version

There are chances that display products on some e-bikes may have a different software version, which is subject to the actual version in use.

◆ Safety Checklist

<ul style="list-style-type: none"> • Safety Check 	<ul style="list-style-type: none"> • Basic Steps
<ul style="list-style-type: none"> • Brakes 	<ul style="list-style-type: none"> • Test front and rear brakes for proper function. • Ensure brake pads are not over-worn and are correctly positioned in relation to rims. • Check that brake control levers are lubricated and tightly secured to handlebars.
<ul style="list-style-type: none"> • Wheels and Tires 	<ul style="list-style-type: none"> • Inflate tires to within recommended limits displayed on sidewalls. • Check for bulges or signs of excessive wear. • Clean tires to ensure tread is exposed. • Ensure rims run true and have no obvious wobbles or kinks. • Check that all wheel spokes are tight and not broken. • Check the wheel balance in Pedal Only Mode. If you notice the riding is imbalanced or the rotation of the front wheel makes noise, it means the bolts were not completely tightened or not aligned horizontally.
<ul style="list-style-type: none"> • Chain 	<ul style="list-style-type: none"> • Check that chain is oiled, clean and runs smoothly. • Use extra care in wet or dusty conditions.
<ul style="list-style-type: none"> • Cranks and Pedals 	<ul style="list-style-type: none"> • Securely tighten pedals to cranks. • Ensure cranks are securely tightened and are not bent.
<ul style="list-style-type: none"> • Motor Drive 	<ul style="list-style-type: none"> • Ensure hub motor is spinning smoothly and motor bearings are in good working order. • Check that all power cables running to hub motor are secured and undamaged. • Make sure hub motor axle bolts are secured and all torque arms and torque washers are in place.
<ul style="list-style-type: none"> • Battery Pack 	<ul style="list-style-type: none"> • Ensure batteries are charged before use. • Check for any visible damage to battery pack. • Lock batteries securely to frame.

◆ Safety Precautions

The following safety notes provide additional information on the safe operation of your Emma 3.0 bike and should be closely reviewed. Improper operation, or failure to confirm correct installation, compatibility, and maintenance of any component or accessory may result in serious injury or death.

◆ Before Riding

- All users must read and understand this manual before the first use. Additional manuals for components used on your bicycle may be provided and should also be read before use.
- Ensure you understand all instructions and safety notes/warnings.
- Follow the safety checklist before first use and at regular intervals to ensure correct tightening and setup of your bicycle.
- Ensure the bike fits you properly before first use. Check local rules and regulations before riding.
- It is your responsibility to familiarize yourself with the laws and requirements of operation of this product in the area(s) where you ride.

◆ While Riding

- Always wear an approved bicycle helmet whenever using this product and ensure that all helmet manufacturer instructions are used for fit and care of your helmet. Failure to wear a helmet when riding may result in serious injury or death.
- Acceleration can be unexpectedly strong in pedal assist mode (Pedal Assist level 1-5), as when you pedal the motor assist will

-
- suddenly engage. Therefore, please pay careful attention when riding. We suggest you use Pedal Only Mode (Pedal Assist level 0) when you need to ride at a slow speed to cross roads, at intersections, or when pedestrian traffic is present, in order to avoid accidents caused by sudden acceleration.
 - Make sure you secure the front wheel, checking the wheel balance in Pedal Only Mode. If you notice the riding feels imbalanced, or the rotation of the front wheel makes noise, it likely means the bolts were not completely tightened or didn't align horizontally in the center.
 - Off-road riding requires close attention and specific skills, and presents variable conditions and hazards which accompany the conditions.
 - Wear appropriate safety gear and do not ride alone in remote areas.



Attention:

A. Electric bike riders must be at least 16 years old. Please abide by the local road traffic safety rules, wear a helmet when riding, and check the e-bike safety according to the safety checklist before riding.

B. Keep the key with extra care because there is only one pair, even the manufacturer doesn't own a back-up. And the keys are to lock/unlock the battery, not the bike.

◆ Emma 3.0 Use and Care

◆ Considerations for safe riding

- 1. Please observe traffic regulations and drive it safely. Please control the speed within safe speed range (note: safe speed of this bicycle is within 48km/h).
- 2. Before driving, get familiar with this Instructions first, and then perform exercise at an open site. Make sure that you fully master driving skills and get familiar with the structure and performance of this bicycle, which are the foundation for safe driving.
- 3. Do not lend it to those person who are not familiar with or unable to drive it or ask them to drive it. It is dangerous to drive it by one hand or even without hands or drive it when intoxicated.
- 4. Take more care when driving it in raining or snowy days: danger may occur due to wet ground in raining or snowy days! Thus, you should drive it a low speed and take more care when turning. You must particularly remember that you do have to brake in advance in raining or snowy days to prevent accidents!!
- 5. Wear a helmet correctly: wear a helmet correctly and tighten the belt when driving. And wear suitable clothing: do not wear tights so that your whole body can move freely. You should wear clothing with sleeves unopened and low-heel shoes as practicable as possible.
- 6 Note: in order for ease maintenance, repair and service, each bicycle produced by our company is marked with a bicycle motor number, so as to assist distribution unit to provide better service for you. The battery number is engraved on the battery, and the motor number is engraved on the outer housing cover of the motor.
- 7. Do not overload: the max. load of this bicycle is 450LB, The handling feeling of handlebar with load is different from that without load. when many articles are loaded, holding handle bar will vibrate, resulting in danger.

◆ Methods for correct operation

• Driving method

- 1.Keep the natural posture, and free driving can be gotten.
- 2. Driving in sitting posture: please always keep your body at the center of the body to prevent load reduction of the front tire and danger caused by handle bar vibration.
- 3. Driving in standing posture: when speeding up. you should turn the turning handle slowly. Danger caused by instability due to sudden speeding-up should be avoided.
- 4. Drive it slowly on roads with surface damaged or that paved with gravels. In raining or snowy days, wet ground will easily cause side slip, so you should drive it slowly with much attention.
- **Parking method** : When parking, please pay attention to those vehicles and pedestrians around. Park it to the right side of flat road slowly, do not park it on a slope. After parking it stably, turn the power supply lock rightwards to pull it out and take it down and then lock the bicycle with a lock.
- **Operation method:** At full charge of capacity,the battery has a green light, with 4 grids in total, with each grid of 25% of rated electricity. So when you find there are only one green grid left, you should charge the battery immediately.
- **Half-twist throttle (speed-governing handle)** :Twist the throttle on the right hand, the bicycle will be sped up; and if it is released to turn back, the speed will be reduced.

• Operation method of disc brake and considerations

(1) Operation method of disc brake

Brake clearance adjustment: turn the adjusting screw which is located between the braking handle and the handlebar tube using a 2mm Allen wrench, adjust the clearance between braking pads and the braking disc until your hand feeling is comfortable.

Replace the braking pad when braking pads are worn off by more than 1 mm or the adjusting screw of braking pads are adjusted to the end position or every half a year. when replacing braking pads, press in one of braking pads using a clean slotted screwdriver to vacate space for taking out the other braking pad. After replacement is complete, it is needed to return the adjusting screw of braking pads to a suitable position (a position that makes your hand feeling comfortable).

Run-in period: the run-in of disc brake surface needs a certain time. After complete run-in, braking force will increase significantly.

The first week in which you use a new disc brake is the run-in period. During run-in period, do not brake with too great force, otherwise unrecoverable damage will be caused to braking pads and braking body. The correct operation method is to brake slightly during driving, so that there is appropriate friction kept between braking pads and the disc brake.

(2) Considerations

Do not use lubricating oil around the disc brake and braking pads, as well as the caliper. Do not touch the surface of disc brake and braking pads with hands, otherwise braking performance will be reduced significantly. You'd better not shower a new brake to prevent a small quantity of lubrication grease in assembling clearance from contaminating braking pads. Oil hydraulic disc brake has strong braking force, you need to do much exercise at a safe place, so as to adapt to the difference from a common brake to avoid braking with too great force, resulting in injury due to wheel lockup.

◆ Operation method of the charger and considerations

(I) Operation method

① when charging, plug in the plug of cell box first, then that of electric supply AC100V-230V. when charging is complete, take the counter procedures, that is, unplug the plug of electric supply AC100V-230V, then that of cell box.

② During normal charging, the indicator light of the charger shows red. when fully charged, it will show green;

③ If charging ambient temperature is too high, the red light will flash, which indicates that the charger is in the temperature protection state.

Please take the charger to a cool or well-ventilated place. when the inside temperature of the charge lowers to 60°C, normal charging occurs.

(2) Considerations

1 The charger can only be used indoors.

2 Charging in a closed space or under scorching sun or at a high temperature environment is strictly prohibited. Do not put the charger on a seat cask or inside the rear compartment for charging.

3 In case of no charging, do not connect the charger to an AC power supply without load for a long time. During charging, if the indicator light is abnormal, there is abnormal smell or the housing of the charger is too hot, please stop charging immediately, and repair or replace the charger.

4 Do not disassemble or replace the devices inside the charger by yourself.

5 Do not charge the charger that has been fully charged.

6 Do not use the charger in an environment with flammable gas, otherwise explosion or fire will be caused.

7 Do not place the charger near water source or wet it, otherwise fire or electric shock may occur.

8 In the event that inside parts are exposed due to charger damage caused by collision, etc., do not touch them with hands, otherwise you may be injured due to electric shock.

(3) Charging

1 Make sure to charge using the charger specifically equipped by our company. Irregular or non-conforming chargers may reduce life the cell or invalid the cell!

2 The cell that has been fully discharged (the bicycle stop running) can be charged with more than 95% of electricity within 5h, and can be fully charged within 8h.

3 During charging, neither the positive end nor the negative end is allowed to be contacted with metal.

4 When leaving factory, the cells electricity is about 80%. Prior to driving a new bicycle, charge it for 3~10h.

5 If the bicycle is left for more than one month, electricity will reduce by about 5%. It is recommended to charge it before use. Please charge the cell timely to ensure driving mileage.

6 During charging, the charger may became hot. As long as the temperature does not exceed 60C. it is normal. when charging, please put the charger and the whole bicycle at a stable and dry place which is free of flammable and explosive goods and is out of

reach of children.

7 You should charge the cell within 24h after it is fully discharged, and charging time should not be less than 3h.

8 Make sure that there is no short-circuit at the charging port.

(4) Discharging (use)

1 Do not use the cell for purposes other than the electrical bicycle of this model, otherwise warranty will not be provided.

2 Once short-circuit occurs, the cell management system will provide automatic protection, and the fuse piece connected in series with power line will fuse, giving dual protection for you cell. At about 2min after the short circuit is released and the fuse piece is replaced, the cell will work normally.

3 Damage or unreasonably configuration of the controller, motor, lighting facility, etc. of electrical bicycle all will cause the cell to discharge at high current. At this time, the cell will stop output for protection, but will recover within 10s, which will not have any effect on your driving.

4 Working temperature range of the cell: -10C —55C. Like other cells, its available energy will reduce with the rise of temperature, which is a normal phenomenon.

(5) storage

1 If long-time storage (more than one month) is needed, it is recommended to charge the cell to 60%—80% of electricity. During storage, it is needed to charge the cell every 3 months, and charging is also needed before usage

2 The cell should be stored at a cool and dry environment.

3 During storage, prevent conductive objects connecting the positive pole with the negative one.

4 Do not use the cell near fire or heat source. (Do not disassemble the cell.)

(6) warning

1 If the cell is found to deform or become hot, you should stop using and seek help from our company or repair department.

2 In case of fire, do not quench the fire directly using water. It is recommended to quench it using and, foam extinguisher or thick clothing soaked with water.

3 For the cell fault caused by delayed charging fully-discharged cell, warranty will not be provided.

4 Do not discard the cell haphazardly.

◆ Check, cleaning and maintenance

1. Check the whole bicycle at a safe place.
2. Check whether the abnormal part found the day before impacted running.
3. Braking effect of the brake: check whether the braking handle can be holding and pinching gently and whether the clearance is appropriate. Check whether it can brake bicycle normally.
4. Check whether there are chaps, damage or abnormal wear on tires or whether there are such sharp objects as metal, pebble, glass embedded in tires. If the lug on a tire has been worn off by 2/3, replace the tire. Check tires, air pressure according to sunken condition of the part of tires contacted with ground. The normal air pressure of front and rear tire is 1.5kg/cm².
5. Check whether the power supply voltage indicator indicates full capacity.
6. Steering system: swing the handle and front fork upwards, downwards, forwards, backwards, leftwards and rightwards to check whether tightness is suitable and steering is flexible, and whether there are such problems as abnormal sound caused by collision, steering system loosening, collision sound. If there are, please contact the distributor, so as to provide perfect after-sale service for you.
7. Check whether the front and rear wheel shaft become loose.

◆ Basic Troubleshooting

No	Symptoms	Possible Causes	Solutions
1	Speed-governing fault or max. speed reduced	<ul style="list-style-type: none"> ● Too low cell Voltage ● Speed-governing throttle damage ● Spring inside throttle goes stuck or fails 	<ul style="list-style-type: none"> ● Charge the cell ● Go for the distributor for replacement
2	Motor not working	<ul style="list-style-type: none"> ● The cells connecting line becomes loose ● .Speed governing throttle damaged ● Motor output line becomes loose or damaged 	<ul style="list-style-type: none"> ● Reconnect it: ● Ask the distributor for replacement ● Ask a repair store for help
3	Continuous riding mileage is not sufficient after charging.	<ul style="list-style-type: none"> ● Low tire pressure ● Low battery power or charger fails ● .Aging of the cell or damaged ● Driving on rough terrain ● Great headwind, frequent braking and starting, heavy load on bike 	<ul style="list-style-type: none"> ● Inspect tire ● Fully charge the cell or replace the charger ● Replace the cell ● Adjust route ● Adjust bike load,include pedal assist use
4	Charger fails to charge	<ul style="list-style-type: none"> ● Charger nor properly connected ● Fuse inside the cell box fused ● Battery packs connecting wire falls off 	<ul style="list-style-type: none"> ● Inspect connections ● Replace the fuse ● Weld connecting wires
5	Other symptoms	<ul style="list-style-type: none"> ● Fault that you cannot determine; the inside of the motor, cell, controller, charger, etc. damaged 	Please ask the distributor for repair, do not open these parts by yourself. Otherwise, warranty will not be provided.

◆ Quality Assurance and After-Sale Service

1. Administration of Quality and Technology supervision

In order to practically protect consumer's legal rights and Interests, perfect the civil responsibility system about product quality and perform warranty obligation and responsibility, you can enjoy 2-year warranty service from the maintenance & service station designated by the bicycle-selling unit by virtue of the warranty card, and specific provisions are as follows:

2. Warranty authentication standard of e-bike

Number	Part name	Standard for replacement	Standard for non-replacement	Quality assurance time
1	Handle Tube	Broken	1. Damage caused by human factor or improper use; 2.The user changes the state by himself: 3. seriously defective accessories	2 years
2	Front Fork	Broken	Damage caused by human factor or improper use	2 years
3	Bottom Fork	Broken	1. Damage caused by human factor or improper use; 2. The user changes the state by himself: 3. seriously defective accessories	2 years
4	Bicycle Frame	Broken	1. Damage caused by human factor or improper use; 2. The user changes the state by himself: 3. seriously defective accessories	2 years
5	LCD Display	Broken	1. Damage caused by human factor or improper use; 2. The user changes the state by himself: 3. seriously defective accessories	1 year
6	Controller	Failure	Improper use or man-made damage	1 year

7	Lithium Cell	In case that the capacity fading all the 15th month as from manufacturing date is lower than 40%; in case that the capacity fading at the 16th -24th month as from manufacturing date is lower than 20%.	Housing damage caused by human factor of improper use, incorrect use of the charger, assembly and disassembly the cell by yourself, using the cell at high temperature (A60x*)- discharging at high current for a long time, short circuit caused by man-made immersion water	1 year
8	Rear Hub Motor	Failure	1. Damage caused by human factor or improper use; 2. The user changes the state by himself: 3. seriously defective accessories	1 year
9	Charger	Failure	Improper use or man-made damage	6 months
10	Headlight	Broken	1. Damage caused by human factor or improper use; 2. The user changes the state by himself: 3. seriously defective accessories	3 months
11	Disc brake	The upper or lower oil pump leaked or damaged; the braking handle broken due to manufacturing defect; oil tube damaged or leaked oil, etc.	1. Damage caused by human factor or improper use; 2. The user changes the state by himself: 3. seriously defective accessories	1 month
12	Tire	Broken	1. Damage caused by human factor or improper use; 2. The user changes the state by himself: 3. seriously defective accessories	1 month

◆ Safety and Care Instructions

To ensure safe riding conditions and maximize e-bike longevity, you must follow the guidelines outlined below:

- To clean the e-bike, wipe the frame with a damp cloth soaked in a mild, non-abrasive, non-corrosive detergent mixture. Wipe or spray all unpainted parts with anti-rust treatment after being used in coastal areas or areas with salty air or water.
- Never immerse the bike or any components in water, as the electrical system may be damaged. If the hub and bottom bracket bearings have been submerged in water, they should be removed and re-greased (this will prevent accelerated bearing deterioration).
- Periodically check wiring and connectors to ensure there is no damage, and the connections are secure.
- Store under shelter, avoiding extended exposure to cold or inclement weather. If exposed to rain or excess moisture, dry your bicycle afterward and apply anti-rust treatment to the chain and any other unpainted steel surfaces.
- Regularly clean and lubricate all moving parts, tighten components and adjust as required.
- Your cables, spokes, and chain will stretch after an initial break in period of 80-160 km, and additionally bolted connections can loosen with time and usage. Therefore, we suggest you contact a certified bicycle mechanic every two months to ensure your bike is safe and problem-free for years of use.
- If the paint has become scratched, or the metal chipped, use touch-up paint to prevent rust (clear nail polish can also be used as a preventative measure).

Damage from corrosion is not covered under warranty, therefore special care should be given to protect and extend the life of your bike.

◆ Maintenance

◆ Battery Maintenance

1. Don't fully drain your battery. Turn off the power when the battery charge is low.
2. Fully charge the battery after each use, no matter how much power is used. This will prolong the battery life. If the battery is not used for a long time, store the battery with a full charge and charge it once a month.
3. The Emma Bike can be safely ridden in light rain. However, riding through very heavy downpours or through flooded streets is not recommended, as the crank and/or motor can get wet, which may cause problems.
4. Keep the battery away from open flame or a high-temperature heat source. Do not expose the battery to direct sunlight or recharge immediately after use in high-temperature weather.

◆ Chain Maintenance

1. We recommend cleaning the chain after each ride, especially in rainy and humid environments. Use a dry cloth to wipe the chain and its accessories clean. Use a brush to remove sand and dirt stuck in the chain, along with use warm soapy water if needed. Do not use strong acidic or alkaline cleaning agents (such as rust remover), because these chemicals can damage the chain.
2. Apply lubricating oil after cleaning to avoid rust. First, make sure the chain is dry, and then apply the lubricating oil into the bearings.
3. To prevent unnecessary chain wear, try to maintain a vertical chain position when shifting gears (do not use the smallest gear with the smallest fly wheel, or the largest gear with the largest fly wheel, etc.).

◆ Front Fork Maintenance

1. Always use a clean, oil-free lint-free cloth with plain or soapy water to clean your bike. To prevent water from flowing into the front fork, you can turn the bike upside down. Dry with a lint-free towel after washing. Pay specific attention to the inner tube and the dust seal to reduce wear and prevent thinning of the inner tube, which can lead to significant damage if the aluminum is exposed to air.

2. We recommend using a front fork dust cover to protect the inner tube of your front fork. This prevents dust from entering as well as hard objects from hitting the inner tube.

◆ Brake Maintenance

1. Pad replacement:

Pads should be replaced if they become contaminated or have less than 2.5mm thickness. (Metal plate & wear material)

2. Before riding:

Check the pads for wear or contamination.

Check the hose for cracking, wear or deformation. Replace if necessary. Check if the brake system is operating correctly.

3. After riding:

Check the pads for wear or contamination.

Check the hose for cracking, wear or deformation. Replace if necessary. Check if the brake system is operating correctly.

4. At regular intervals

Check the oil level in the reservoir. Lubricate the brake lever pivot with grease.

Check to make sure that all the bolts are tightened to the correct torque specifications.

◆ Riding Limitations

Following are some limitations needing riders' careful attention to ensure the hub motor does not overheat or become damaged from excessive loading:

- Do not attempt to ride up hills steeper than 15% grade
- Use the pedals to assist the motor when climbing hills and accelerating from a stop.
- Avoid sudden starts and stops.
- Generally accelerate at a moderate pace, rather than aggressively.

■ Range and Content Beyond Warranty

1. The fault caused by failure to use maintenance or adjustment by the user according to the Operation Instructions;
2. The fault against which technical evaluation and analysis cannot be done because original state is destroyed due to refit, disassembly, repair and dismantling by the user himself;
3. Accessories other than that provided by "Roll Road" are used;
4. The fault caused by improper use or maintenance by the user or by accidents;
5. The bicycle without warranty card or the bicycle that is not corresponding to the warranty card;
6. The secondary fault caused by continuous use by the user after a fault occurrence.
7. The bicycle without certificate;
8. Unilateral amendment of invoice date or the part No. on bicycle.

◆ Online Resources

For more information on best practices, maintenance, and more, please visit the Roll Road Bikes website (<https://roll-road.com/>)

If you still have questions after checking out our online resources, please contact us in any of these ways:

Website: <https://roll-road.com>

E-mail: support@roll-road.com

Phone: +1 (860)800-9375