

Masonry Chimney Installation

WARNING: Read this entire manual before you begin building the Mason-Lite Fireplace. It is required that the builder reinforce the lintel with a steel angle to adequately support the Masonry Chimney System. See Page 2.

The MCLS-814 Masonry Chimney System consists of an outer block and a Ø14 inch inner liner flue. The chimney components must be assembled on-site using an approved masonry adhesive to cement the components together. The MFLS-814 chimney system may also utilize offset chimney blocks or a brick ledge component designed to support chimney top brick veneer finishes. A spark arrestor and a masonry chimney termination cap are both required (supplied by others).

Recommended minimum overall chimney height for the Mason-Lite fireplace system utilizing the masonry chimney system is 14'-0" for straight chimney stacks or 17'-0" for chimney stacks with an offset.

Maximum overall height from bottom of firebox is 20'.

The chimney system must always vent vertically to the outside of the building.

The system requires an Anchor Plate/Damper Assembly (**Figure 1**) (MC14-AP) to be installed on top of the fireplace prior to beginning installation of the masonry chimney. Four holes around the flue are used as templates for the rebar locations. Drill 1 inch deep holes into the fireplace Dome Top in order to anchor the four #3 rebar (Ø3/8") required when building a straight flue stack.

If an offset is started directly from the Dome Top, no rebar is required but every 6th offset section needs to be supported (see **Figure 2**).

Figure 2

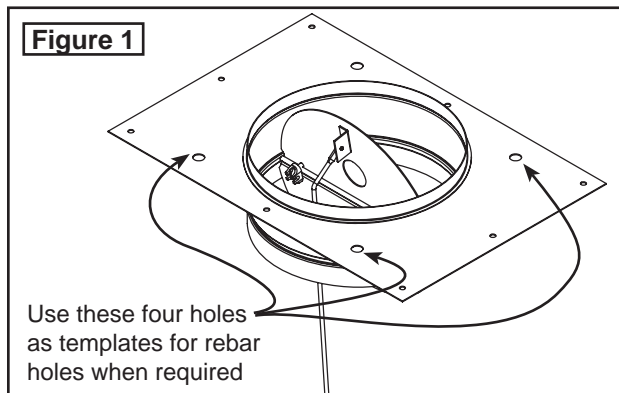
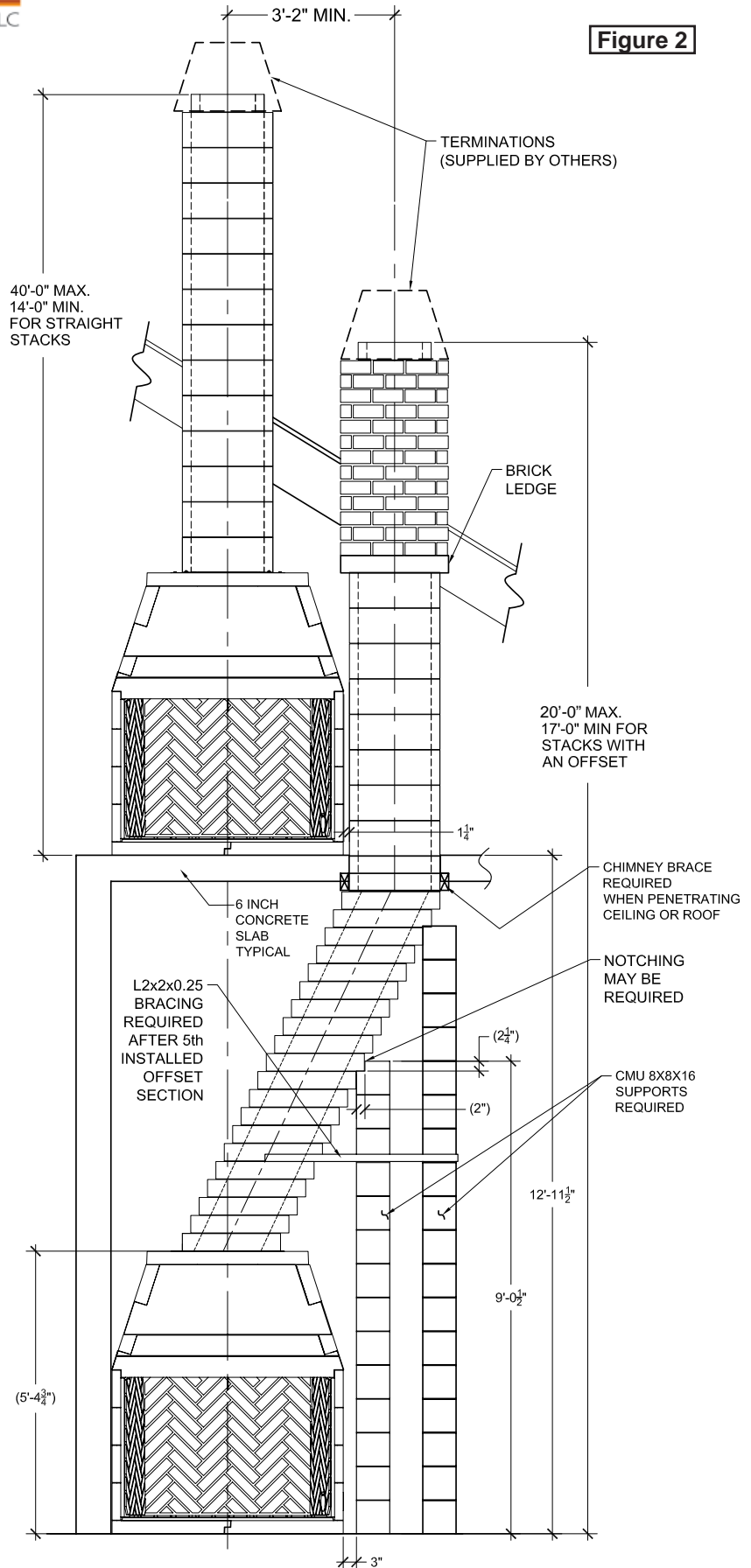

The MCLS-814 Masonry Chimney System consists of the following components:

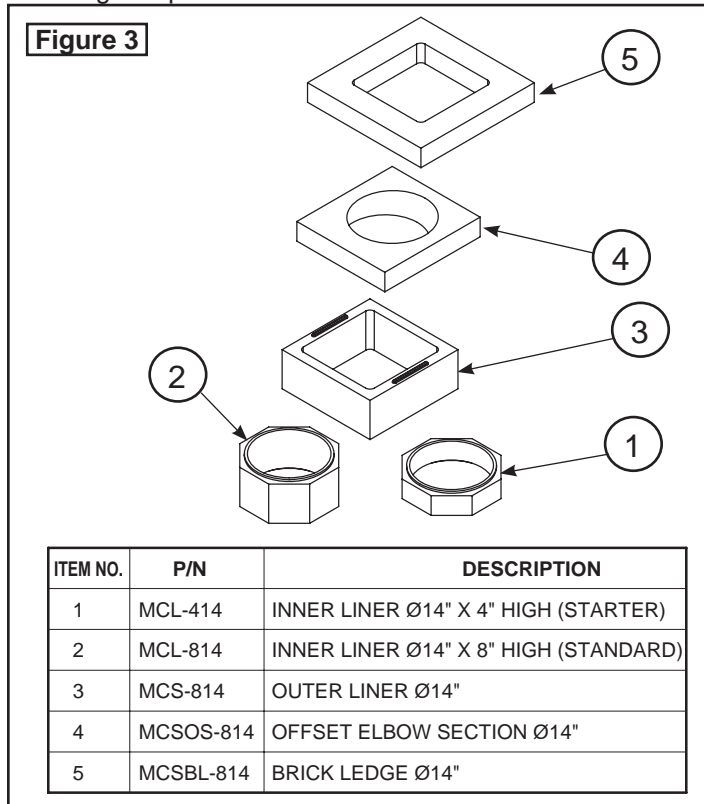

Important Safety Information:

Important: The Mason-Lite fireplace must be supported by a non-combustible concrete slab which in turn is also supported by concrete or steel substructure capable of carrying the total weight of the Mason-Lite fireplace including the MCLS-814 Masonry Chimney System.

Creosote and soot formation and the need for removal: When wood burns slowly, tar and other organic vapors are produced which combine with expelled moisture and form creosote. The creosote vapors condense in the relatively cool chimney flue of a slow burning fire and accumulate on the flue lining. When ignited this creosote makes an extremely hot fire. Because of creosote and soot buildup, it is necessary to inspect and clean the fireplace and chimney prior to use and periodically during the heating season. (Cleaning should be done annually at a minimum).

Before servicing, allow the fireplace to cool. Always shut off any electricity or gas to the fireplace while working on it.

Use only solid fuel, natural or LP gas log sets in this unit. Do not use artificial wax based logs, chemical chimney cleaners or flame colorants in this fireplace.

Never use gasoline, kerosene, gasoline-type lantern fuel, charcoal lighter fluid, or similar liquids to start or "freshen up" a fire in this fireplace. Keep all flammable liquids at a safe distance from the fireplace.

Always keep the flue damper open when heat is present in the fireplace.

Do not use a fireplace insert or any other product not specified for use with a Class A wood-burning fireplace and chimney system unless written authorization is given by Mason-Lite. Failure to heed this warning may cause a fire hazard and will void the warranty.

The manufacturer does not warranty "Smoke free" operation nor is the manufacturer responsible for inadequate system draft caused by mechanical systems, general construction conditions, inadequate chimney heights, adverse wind conditions or any unusual environmental conditions or factors beyond the manufacturer's control.

IF YOU ARE PLANNING TO INSTALL A MASONRY CHIMNEY SYSTEM ON TOP OF YOUR MASON-LITE FIREPLACE, MAKE SURE TO REINFORCE THE UPPER DOME SECTION WITH STEEL - SEE BELOW.

Installation Instructions for Straight Stack

1. During construction of the Mason-Lite Fireplace, you must remember to install the steel lintel support under the rear of the lintel. This should be a minimum 3"x3" steel angle, 3/16" thick. Install the support once the side walls are complete and before the lintel is in place. You may need to notch the side walls so that the support sits securely. See Figure 4 below.

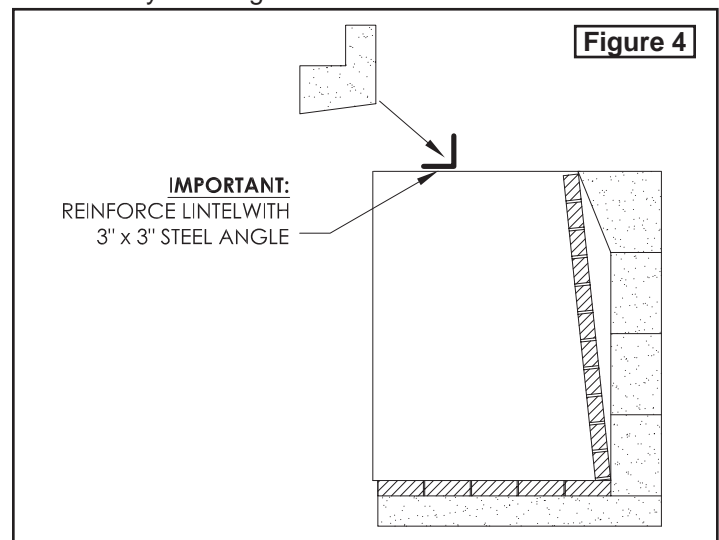

2. After completing your assembly of the Mason-Lite Masonry Fireplace, install the Anchor/Damper Plate Assembly (MC14-AP) as shown in Figure 5. Apply hi-temp sealant around the lower ring just below the plate to prevent flue products from leaking. Use the four holes of the Anchor Plate as a template to drill Ø3/8" x 1" deep holes for the #3 rebar (See Fig.5). Secure with ITW Epoxy or Simpson Epoxy. Follow manufacturer's instructions for proper application of adhesive.

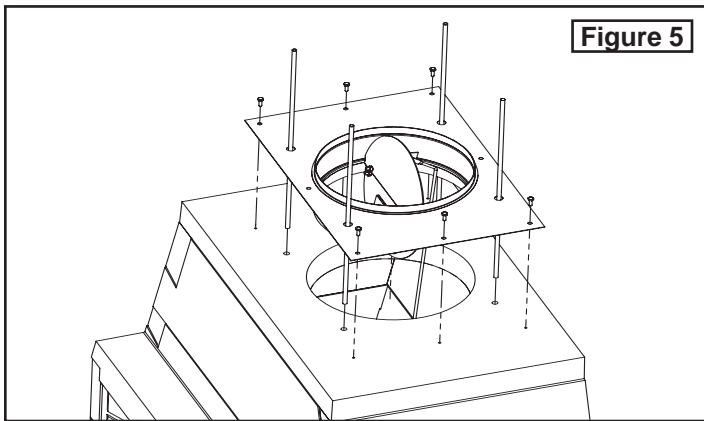

3. Apply mortar to the base of starter section of inner flue (MCL-414). Note: Position inner flue so that a flat face runs parallel with the front face of the firebox. This will allow the Outer Flue sections to follow proper form and fit. If offsets are started directly from the Dome Top, then apply mortar directly to its base and make sure you position a flat side parallel to the firebox face.
4. For a straight stack that begins directly on top of the unit, start with a small 4" high inner flue (MCL-414) and continue with 8" tall inner flue sections (MCL-814) (Figures 6, 7 and 8). When terminating the stack, the inner flue will stick out by 4" and allow for a 4" tall Brick Ledge section to be installed.

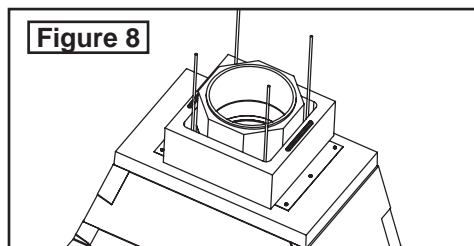
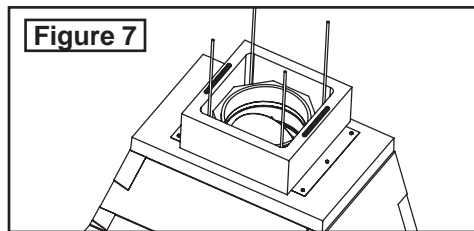
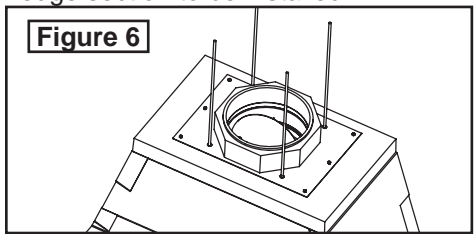

5. If an offset is required after a short run of straight flue, start with a standard 8" high inner flue (MCL-814). The offset will require that the inner and outer flue is flush at the beginning of the offset sections. After the offset is complete, resume the straight stack with a short 4" high inner flue (MCL-414) and continue with 8" high inner and outer sections (MCL-814, MCS-814). At the point

of termination the inner flue should stick out above the outer flue by the 4" which is required for the Brick Ledge section.

6. If an offset is being installed, support is required for every 6th or 7th offset section being installed. Supports need to be installed by a qualified professional. Examples of supports are shown in Figure 2 and Figure 11 showing a support pillar constructed out of 8x8x16 CMU blocks stacked to the side of the unit and including a support brace constructed out of L2x2x0.25 angle iron. Rebar also needs to be used when building your support column. The dimensions shown are nominal and 1/8" grout gaps have been considered (CMU block actual dims. are 7.62" x 7.62" x 15.62" and are shown staggered with a 1/8" grout gap between each).
7. **IMPORTANT!** When applying mortar to each section, it is imperative that the blocks be maintained moist (not soaking) so they don't absorb the water out of the mortar and cause adhesion to fail. Frequently run a damp sponge to the parts before mortar is applied!

Once all sections are completed, install a spark arrestor and termination cap (provided by others) to complete the installation.

Installation Instructions for Direct Offset

1. When starting offsets directly from the top of the fireplace, position the offset section completely to one side of the Anchor / Damper Plate collar. Figure 9 and 10 show the offset section positioned for a left side offset. For right side offsets reverse position. Note that the edge-to-edge distances vary by firebox size.

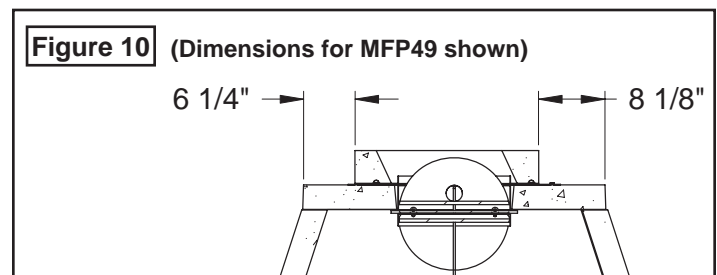
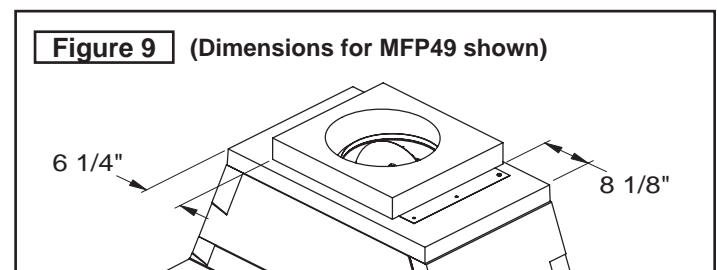

2. Supports are required for every 6th offset. Dimensional characteristics would vary as shown in Figure 11. Make sure rebar is included in the support column. Build the support column centered to the flue as shown in the side view in Figure 11.
3. After the first column support as shown in Figure 11, if continuing the offset sections, another support will be required and must stem from adjoining supporting structure.

WARNING to the licensed design professional and/or building contractor: It is your responsibility to be certain that the Mason-Lite flue system and fireplace can be properly supported by the surrounding structure.

Customer Service and Parts Replacement:

Parts and accessories may be purchased from your local dealer. Additional information is available from Masonry Fireplace Industries, LLC

