

ALTITUDE™ X 42 DIRECT VENT GAS FIREPLACE



Specifications

Model	BTU	Width		Height		Depth		Glass Size
		Actual	Framing	Actual	Framing	Actual	Framing	
AX42NTE	38,000	42 1/4	42 3/4	45 7/16	45 5/8	18 5/8	19	28 3/4 x 37 11/16
AX42PTE	36,500			45 7/16	45 5/8	18 5/8	19	

Dimensions

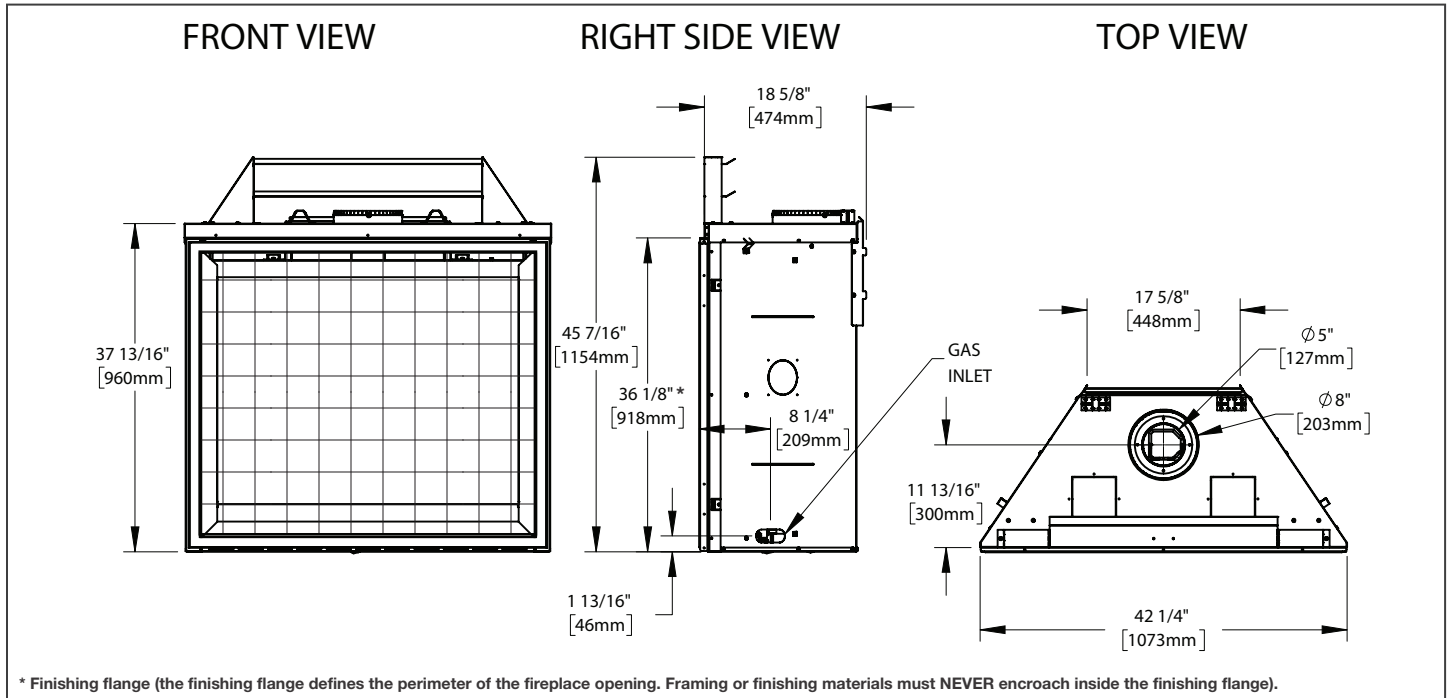

Appliance Location

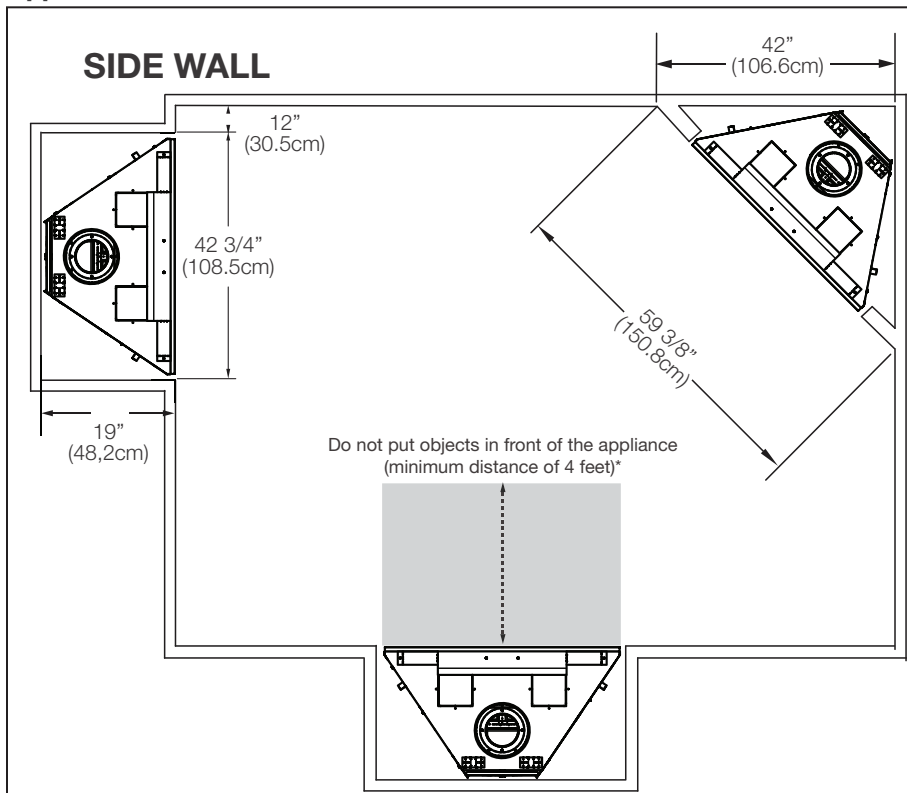

Combustible Mantel Clearances

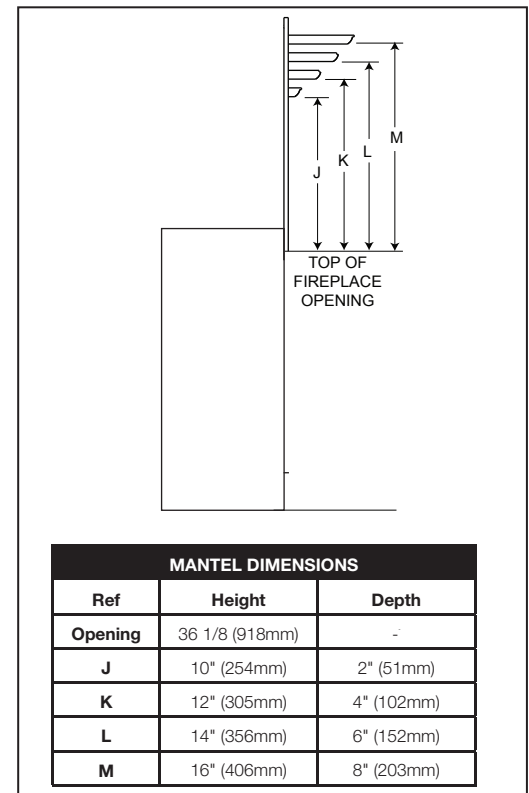

W415-1933 / 05.17.19

ALTITUDE™ X 42 DIRECT VENT GAS FIREPLACE



Product information provided is not complete and is subject to change without notice. Please consult the installation manual for the most up to date installation information.

Wall Penetration

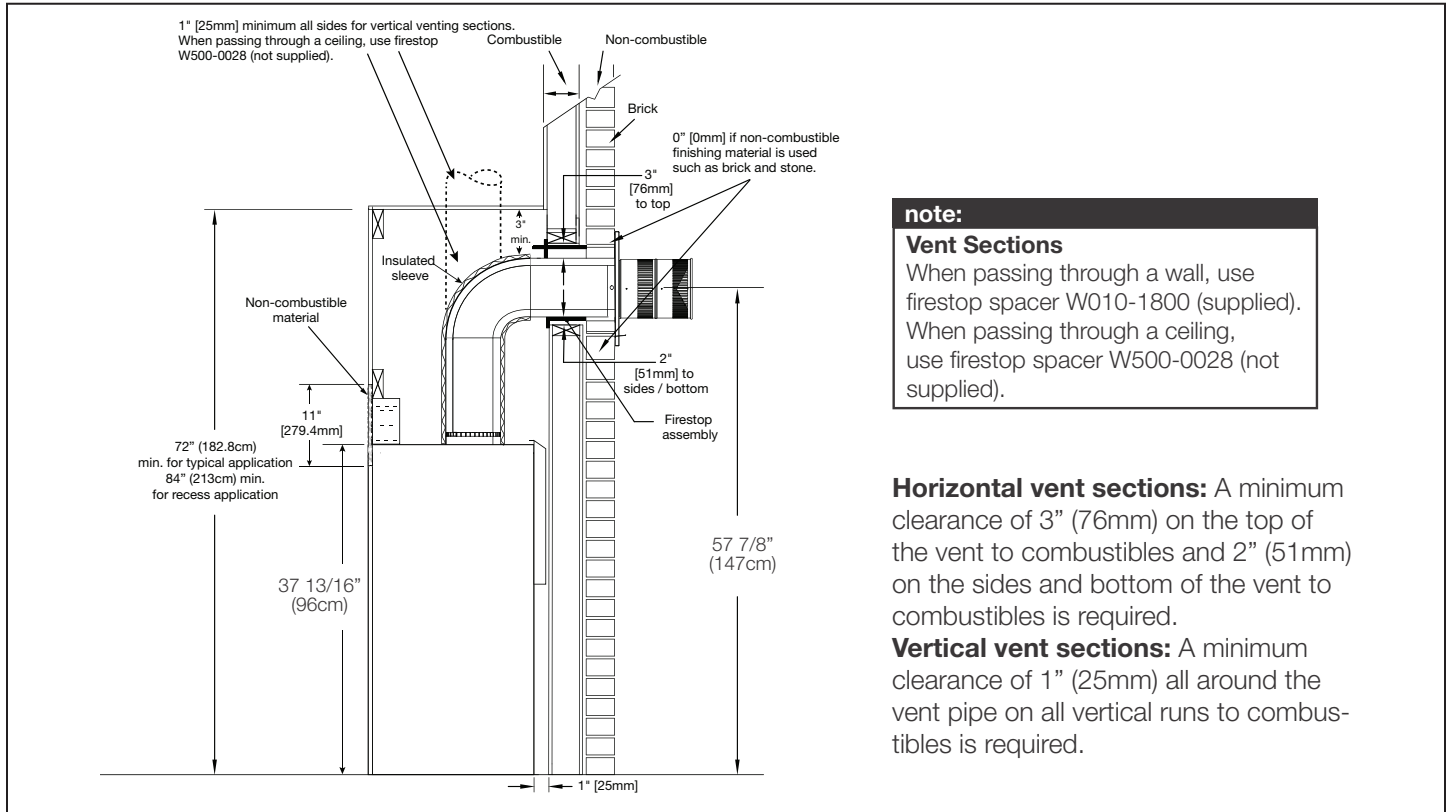

Flush & Recessed Framing

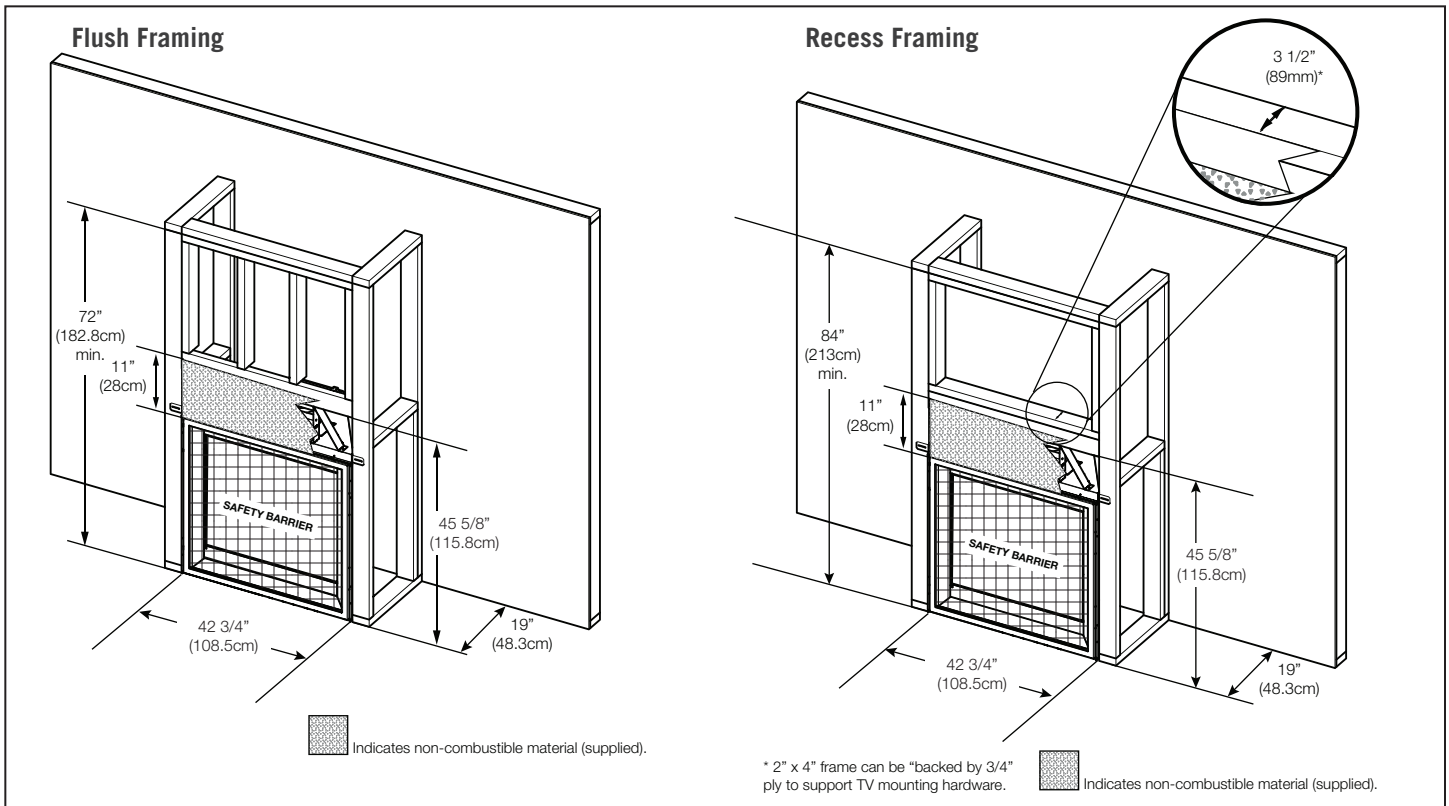

W415-1933 / 05.17.19

Spécifications

Modèle	BTU	Largeur		Hauteur		Profondeur		Taille de Verre
		Réel	Ossature	Réel	Ossature	Réel	Ossature	
AX42NTE	38 000	42 1/4	42 3/4	45 7/16	45 5/8	18 5/8	19	28 3/4 x 37 11/16
AX42PTE	36 500							

Dimensions

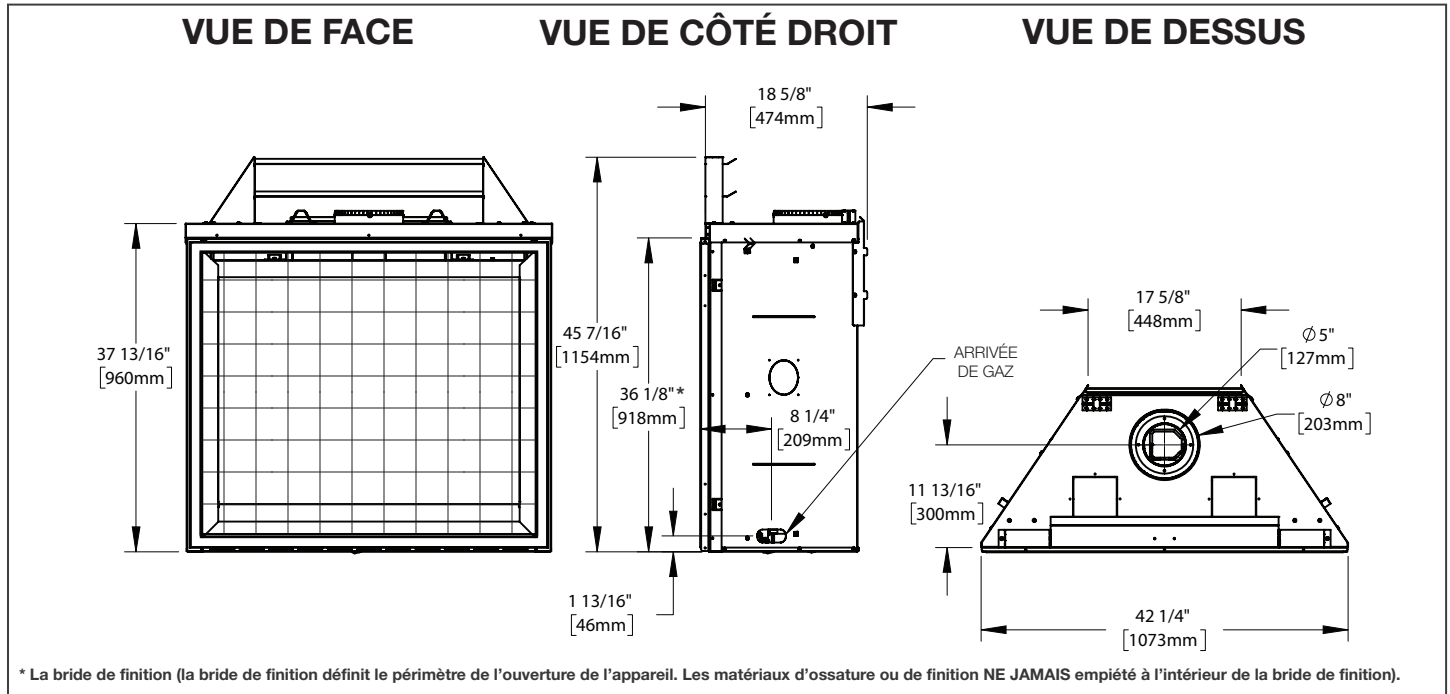

Emplacement de l'Appareil

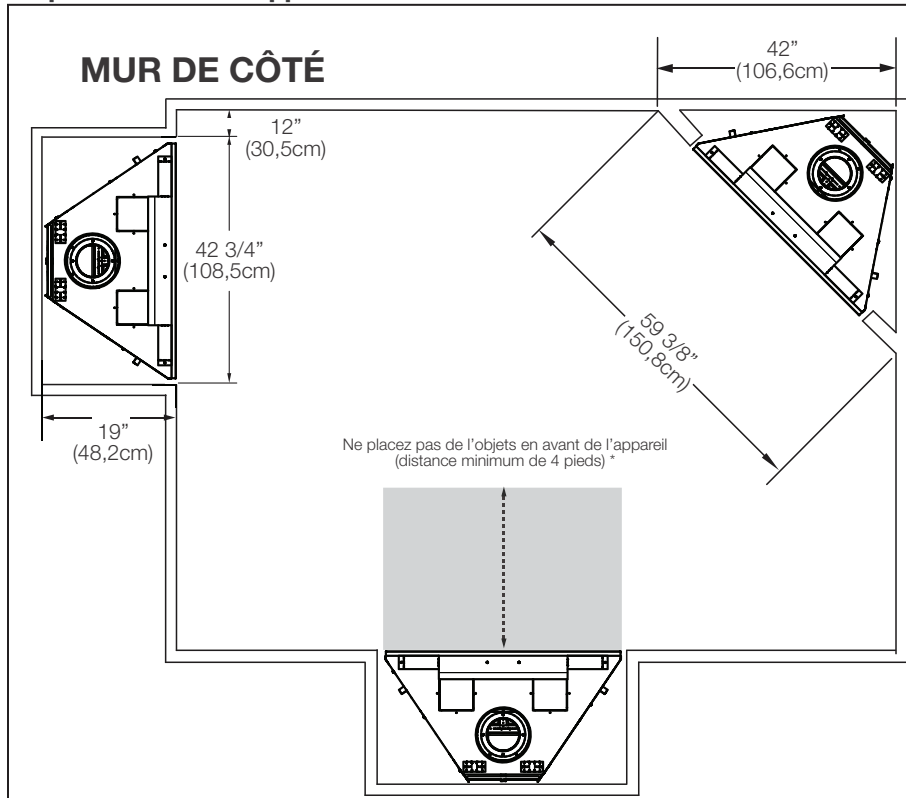

Dégagements Combustible de la Tablette

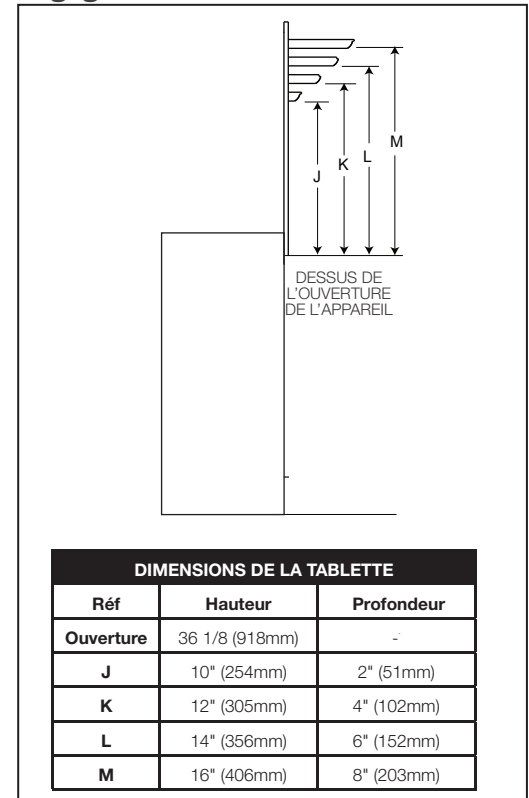

L'information du produit fourni n'est pas complet et est sujet de changer sans préavis. Consultez le manuel d'installation pour information d'installation actuel.

Pénétration de Mur

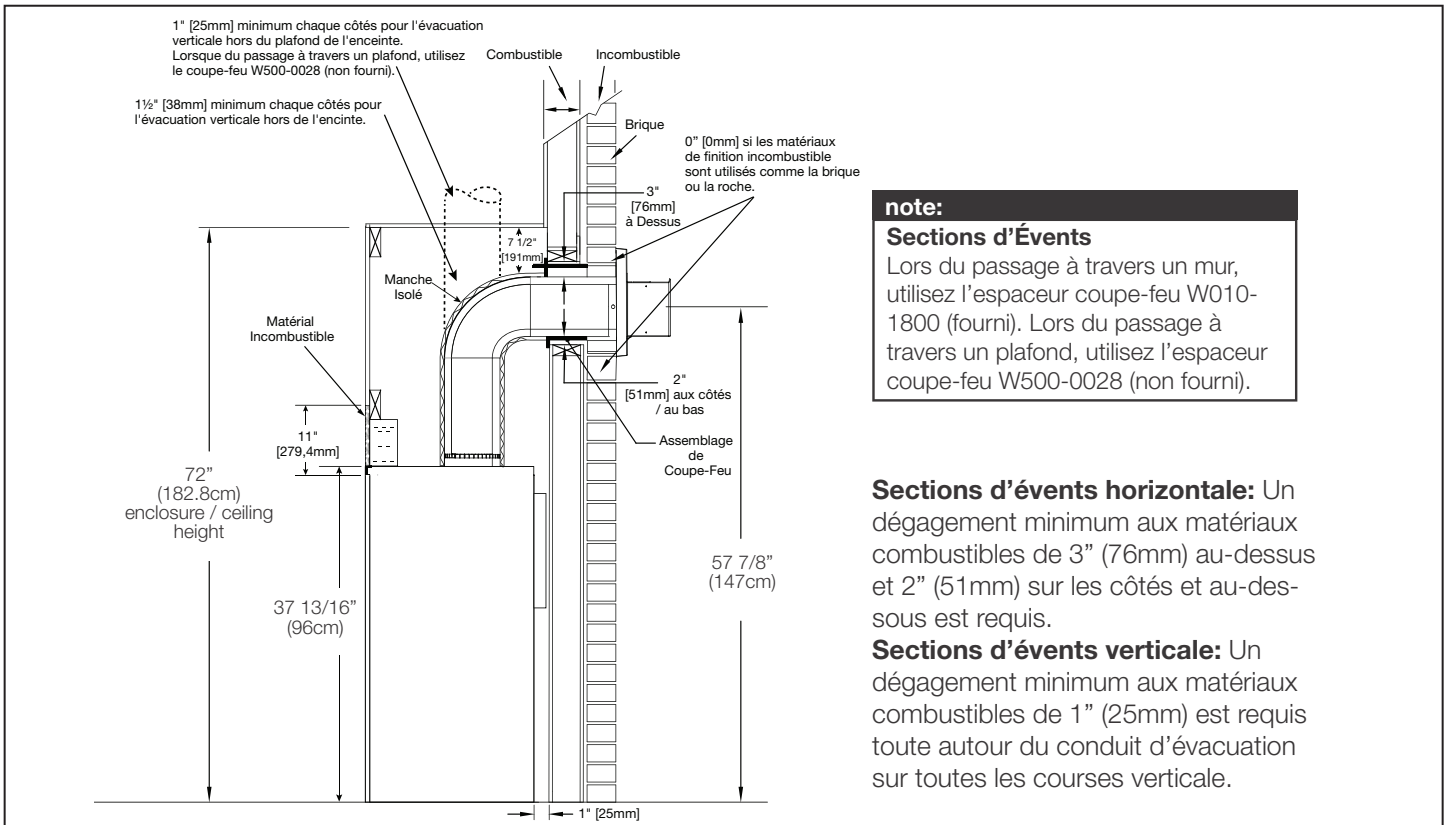

Encadrement Fini Affleuré et Encastré

