

FLORENCE CONCRETE FIRE PIT UNITS WITH PROPANE TANK STORAGE

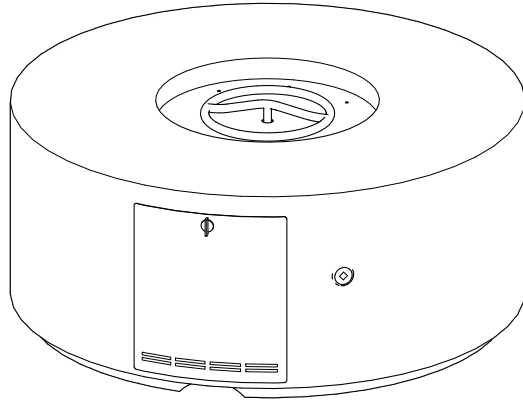

ISOMETRIC VIEW

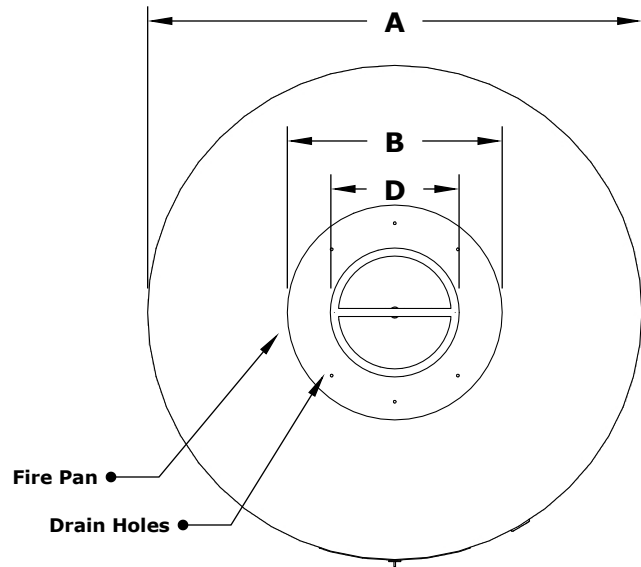

TOP VIEW

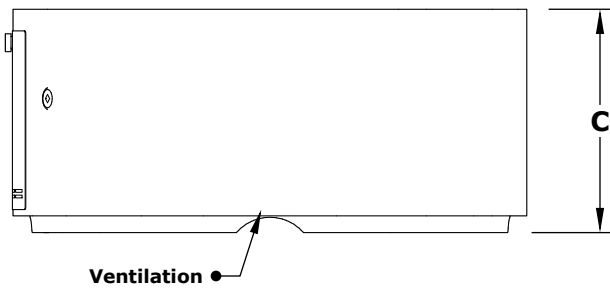

RIGHT SIDE VIEW

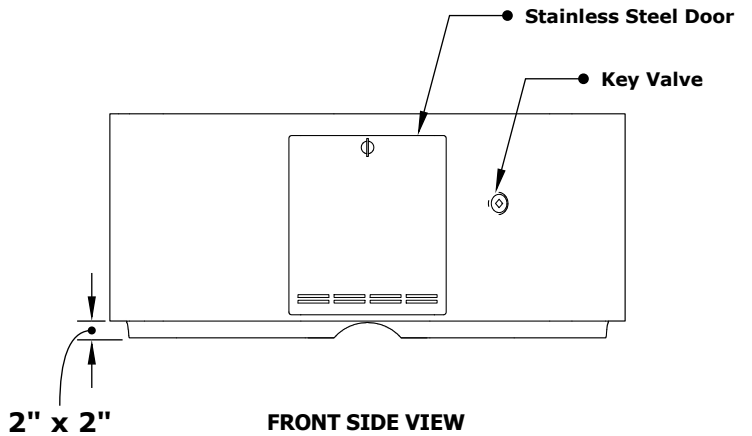

FRONT SIDE VIEW

SKU	A	B	C	D	BTU
OPT-FL4224	42"	25"	24	12"	65,000
OPT-FL4620	46"	21"	20"	12"	65,000
OPT-FL54	54"	30"	20"	12"	65,000
OPT-FL72	72"	48"	20"	24"	65,000
OPT-FL4224EKIT	42"	25"	24	12"	65,000
OPT-FL4620EKIT	46"	20"	20"	12"	65,000
OPT-FL54EKIT	54"	30"	20"	12"	65,000
OPT-FL72EKIT	72"	48"	20"	24"	65,000

Fire Pit Material: GFRC Concrete
Pan Material: 304 Stainless Steel
Burner Material: 304 Stainless Steel

Standard 2" Depth on all pans

110V ELECTRONIC IGNITION
ANSI Z21.97-(2017) / CSA 2.41-(2017)



Match Lit Unit Includes: Pan, Burner, Gas Orifice, Gas Hoses, Key Valve, Key,
110v Ignition Unit Includes: Pan, Burner, Gas Orifice, Gas Hoses, Key Valve, Key, Plug & Play Electronic Valve, Pilot Igniter.