

BASTILLE CORTEN STEEL FIRE TOWER

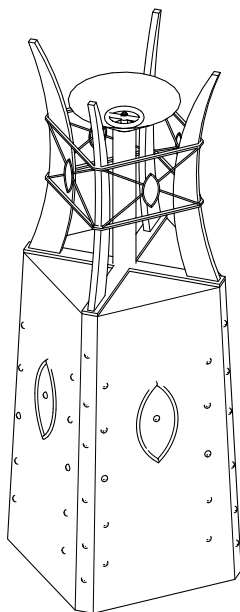

ISOMETRIC VIEW

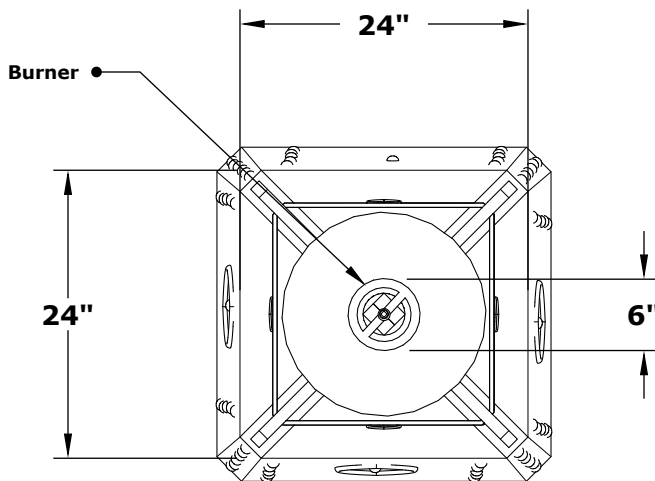

TOP VIEW

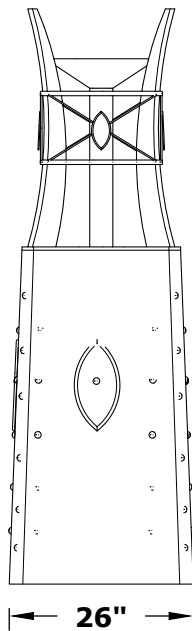

RIGHT SIDE VIEW

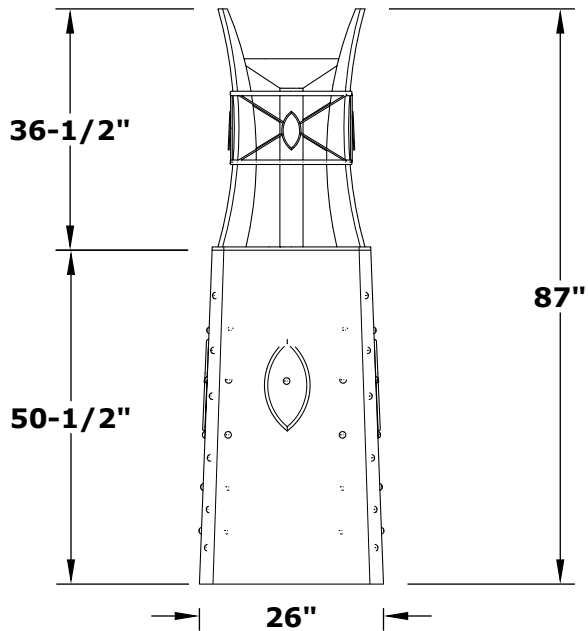

FRONT SIDE VIEW

PART NUMBER	A	B	C	D	E	F	BTU
OPT-FTWR2	24"	26"	87"	36.5"	50.5"	6"	40,000
OPT-FTWR2EKIT	24"	26"	87"	36.5"	50.5"	6"	40,000

Fire Tower Material: Corten Steel
 Pan Material: 304 Stainless Steel
 Burner Material: 304 Stainless Steel

110V ELECTRONIC IGNITION
 ANSI Z21.97-(2017) / CSA 2.41-(2017)



Match Lit Unit Includes: Pan, Burner, Gas Orifice, Gas Hoses, Key Valve, Key,
 110v Ignition Unit Includes: Pan, Burner, Gas Orifice, Gas Hoses, Key Valve, Key, Plug & Play Electronic Valve, Pilot Igniter.

Drawn By	Murguia M.
Date Created	6/2/2021