

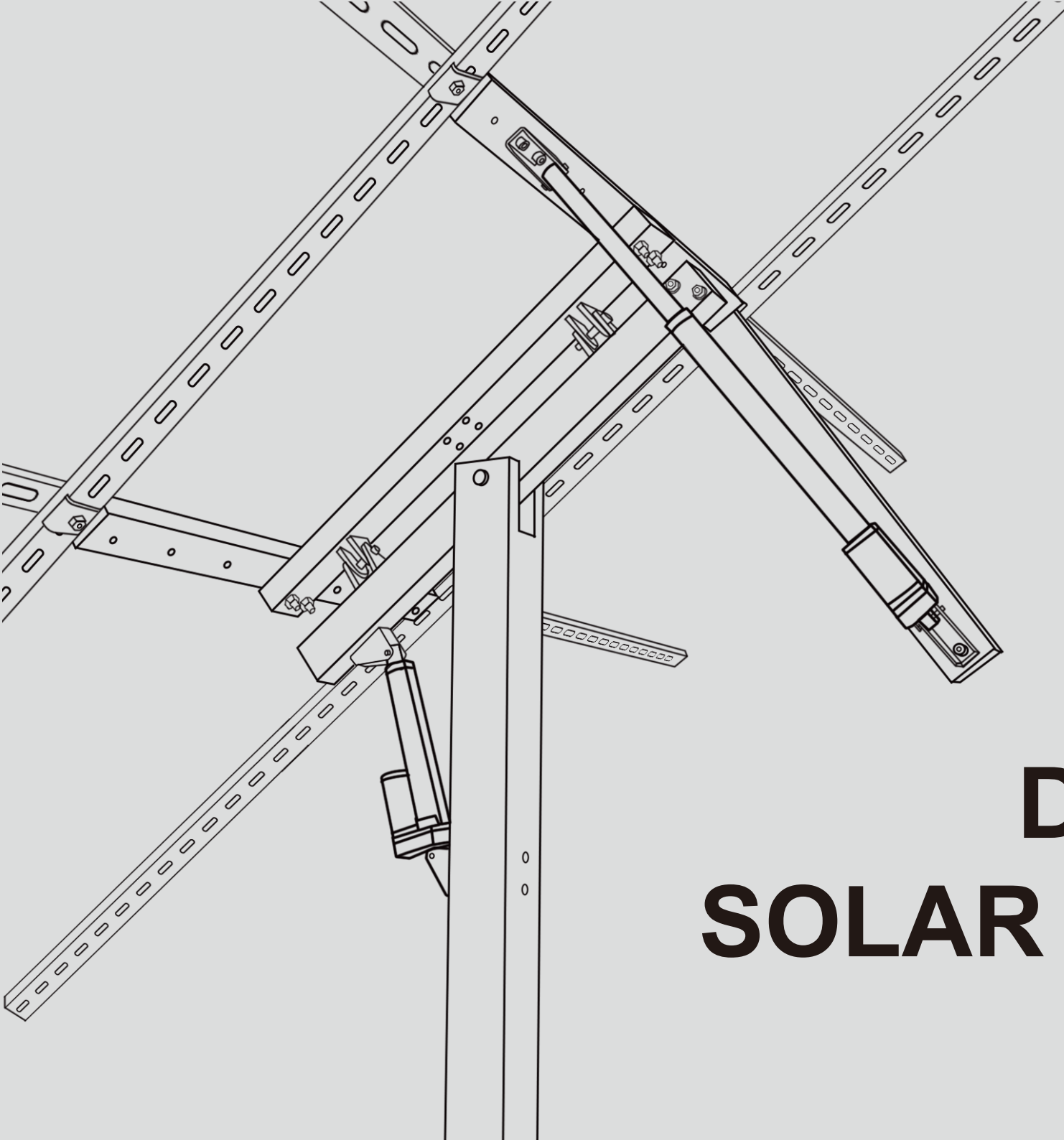

ECO-WORTHY



DUAL-AXIS SOLAR TRACKER

Manual

SAFETY PRECAUTIONS

PLEASE READ CAREFULLY BEFORE PROCEEDING

- For the proper use and maintenance of this product, please read carefully and understand this instruction before installation.
- Make sure that the tracker system is installed on a solid concrete ground which is strong enough to hold the weight of all the tracker and solar panels.
- Make sure all the bolts and nuts are firmly tightened during the installation.
- To adjust the angle of the solar panels, loosen the side clamps and middle clamps first and then move the panels carefully. **DO NOT** adjust the solar panels by force.
- During long-time usage, some components might be loosened or corroded. For safety, please check the tracker regularly.
- In stormy weather with a wind speed greater than 17.2m/s, it is best to remove the solar panels to prevent damage to the bracket.

WHAT'S IN THE BOX

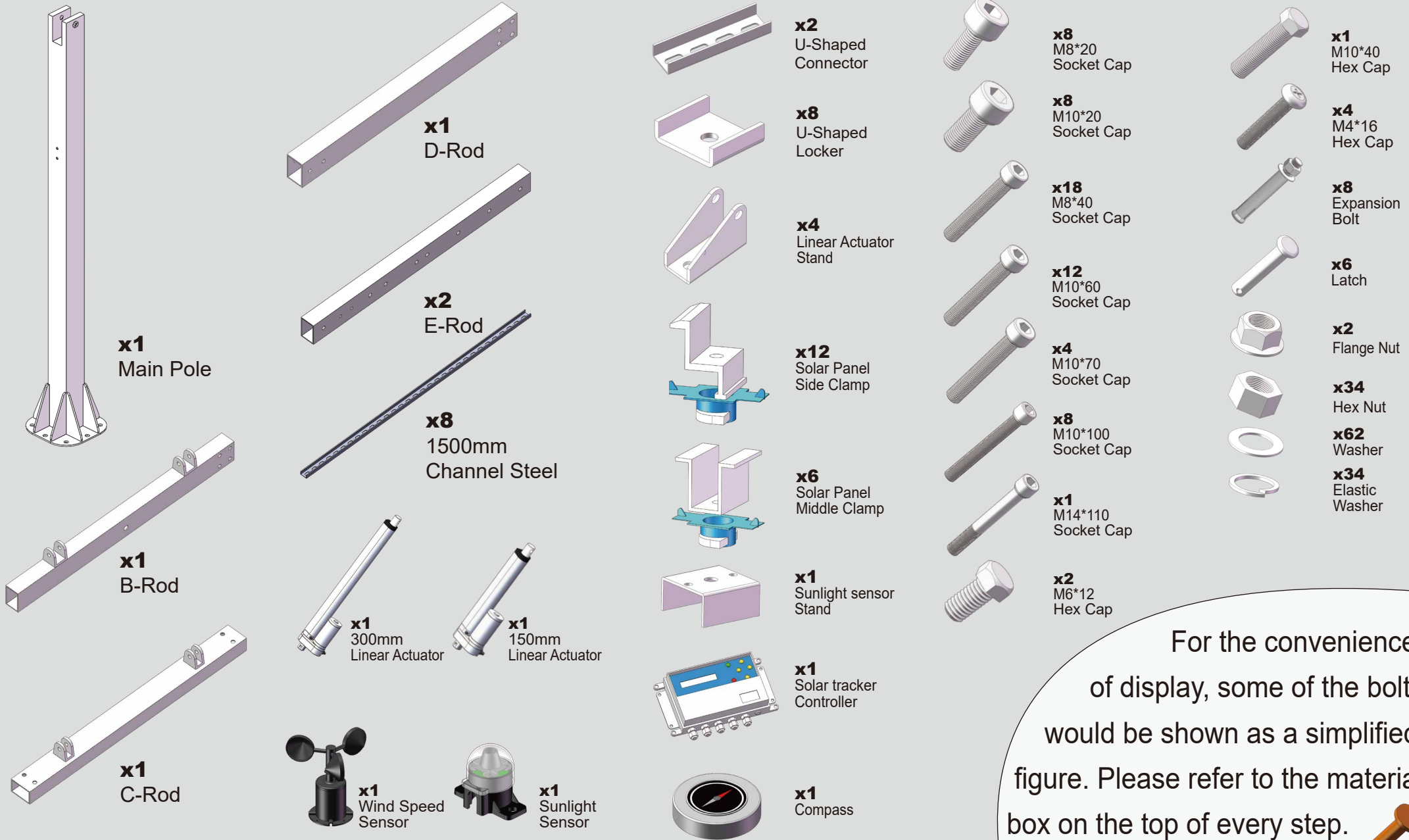

For the convenience of display, some of the bolts would be shown as a simplified figure. Please refer to the material box on the top of every step.



1

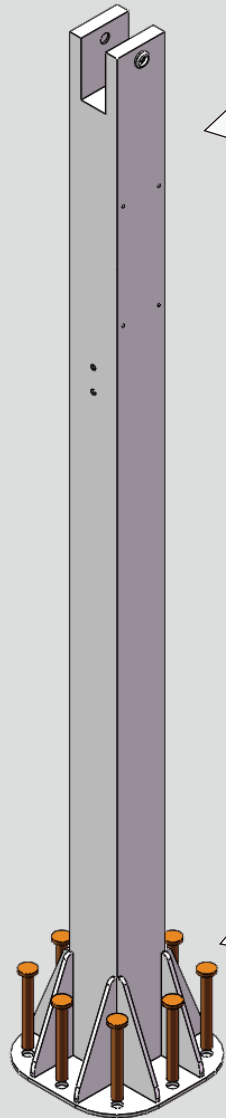
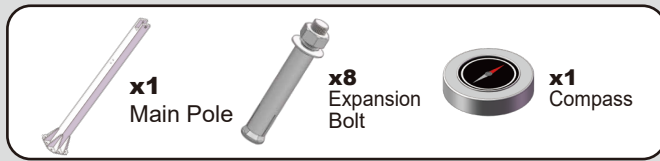

There are 4 signs on the main pole that indicate directions (South, North, West, East). Use the compass to place the main pole correctly so that the the tracker can track the sun properly.

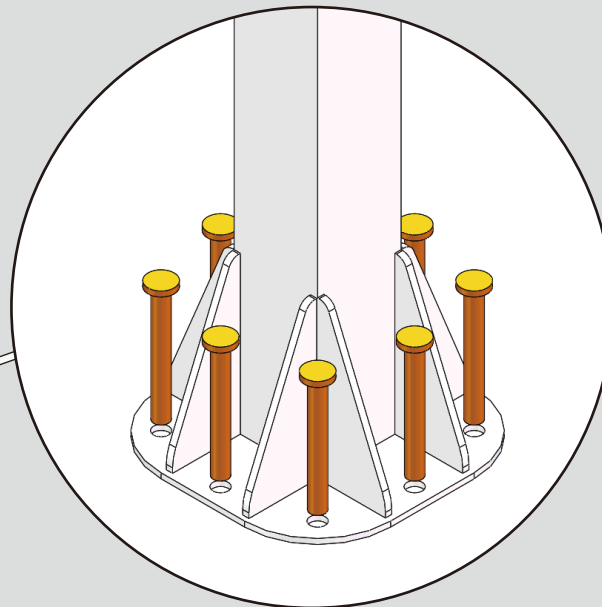

The main pole must be installed on solid concrete ground or pier with the expansion bolts. The solid ground base must be larger or equals to a 600*600*700mm cube.

Recommend concrete material (kg/m³):
Cement(450kg)+Water(183kg)+Sand(600kg)+
Gravel (1192kg)

2

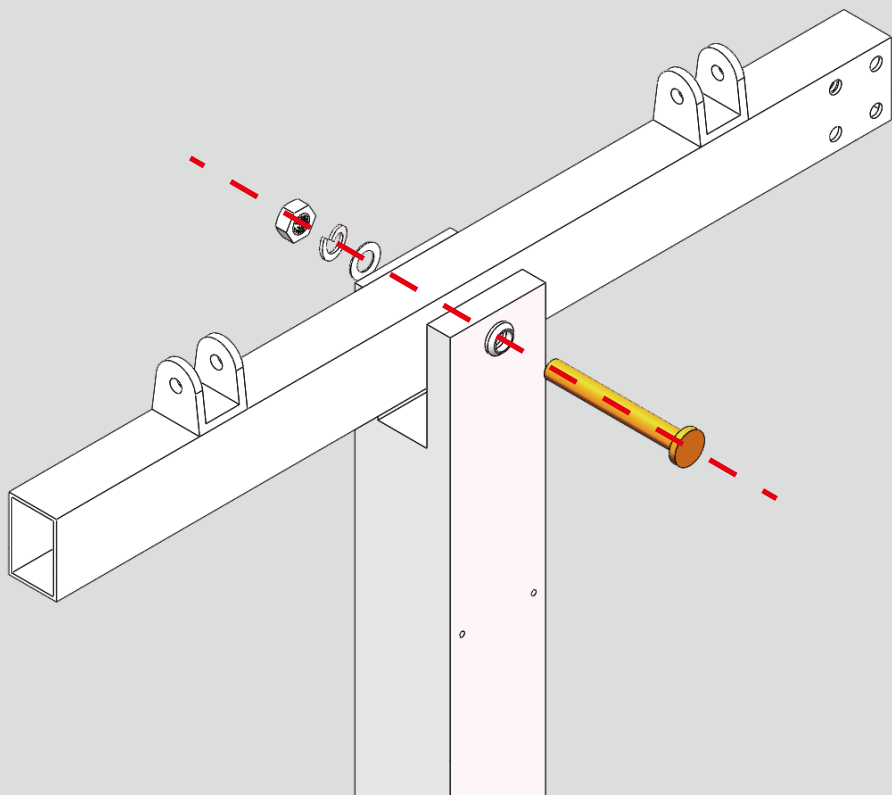

3

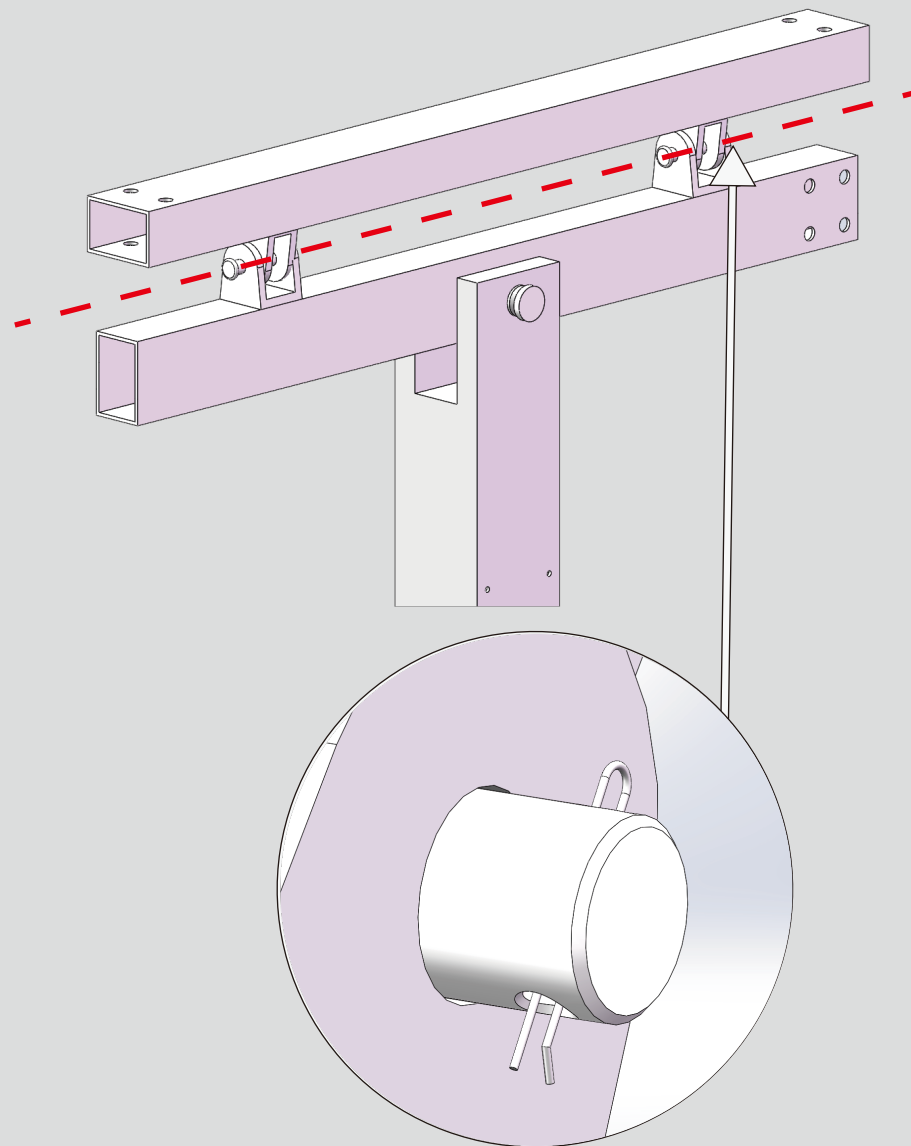
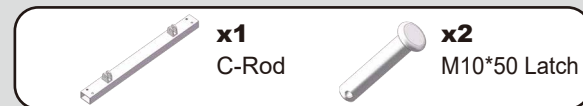

4

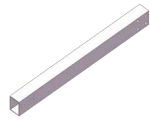

x1
D-Rod



x4
M10*100
Hex Cap

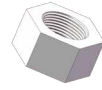

x4
M10
Nut



x4
M10
Washer



x4
Elastic
Washer

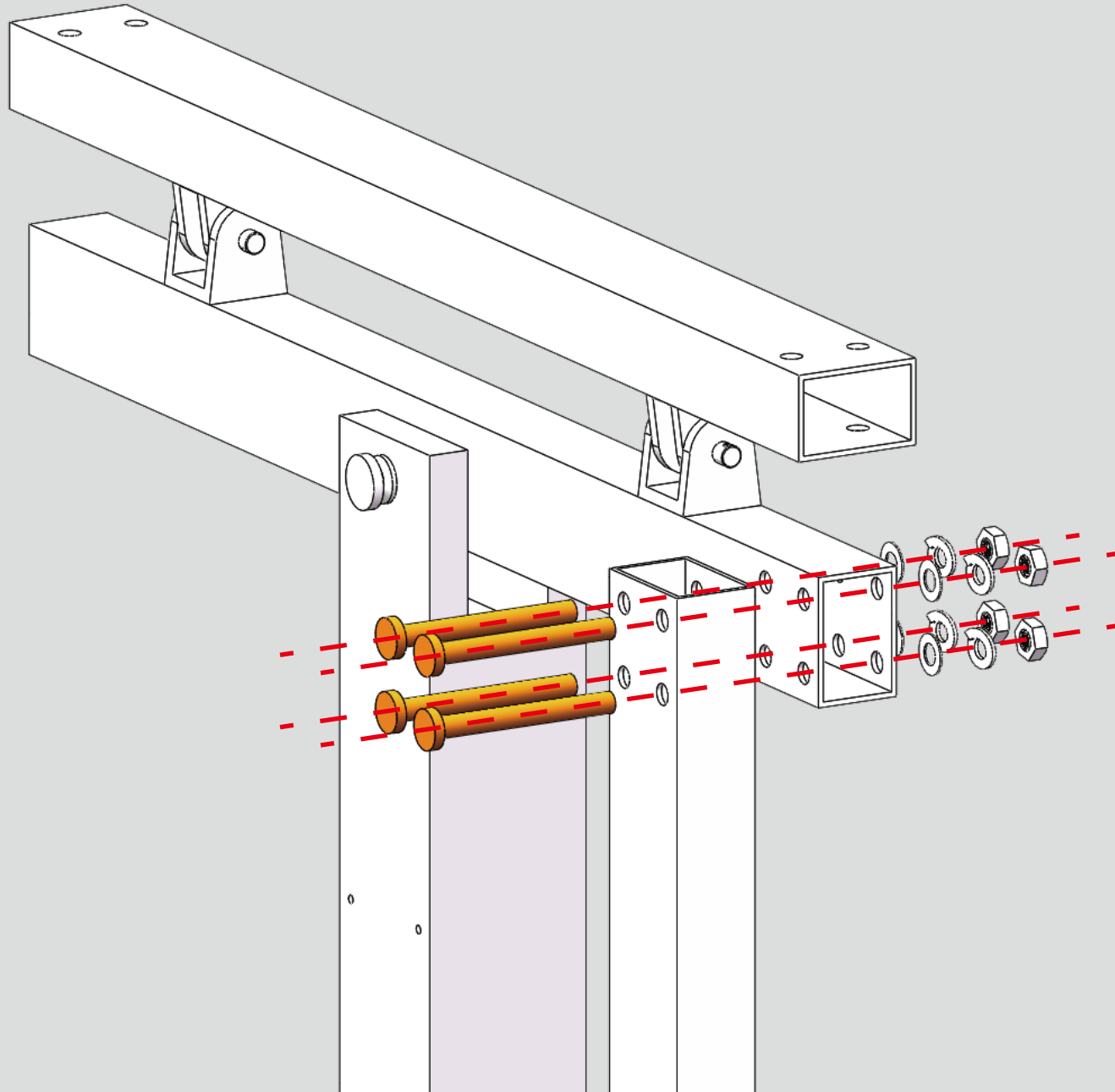

5

x2
E-Rod

x4
1500mm
Channel Steel

x4
M10*100
Socket Cap

x12
M10*60
Socket Cap

x16
M10
Hex Nut

x32
M10
Washer

x16
Elastic
Washer

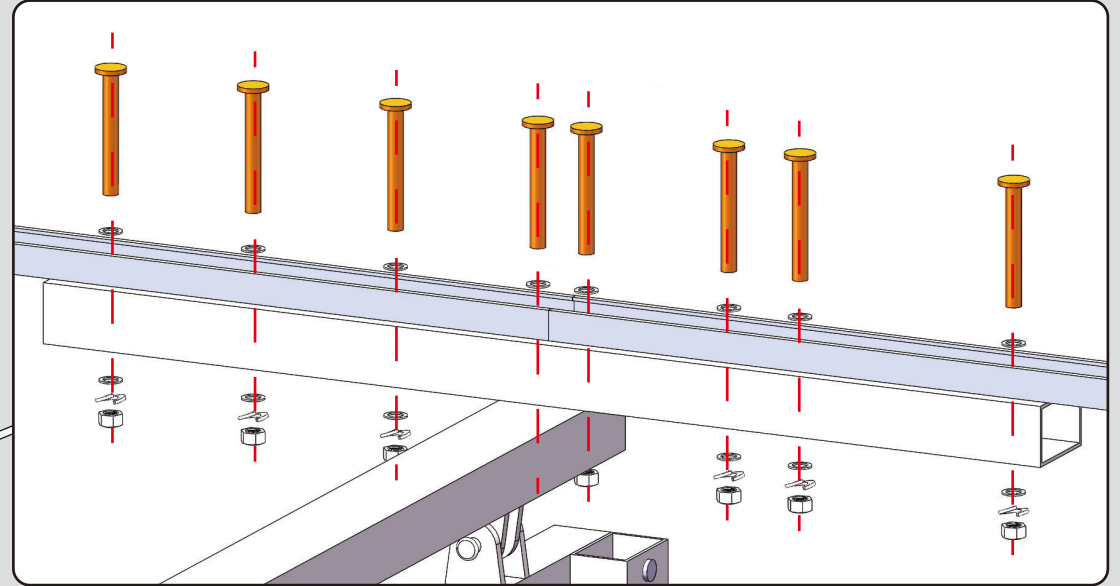
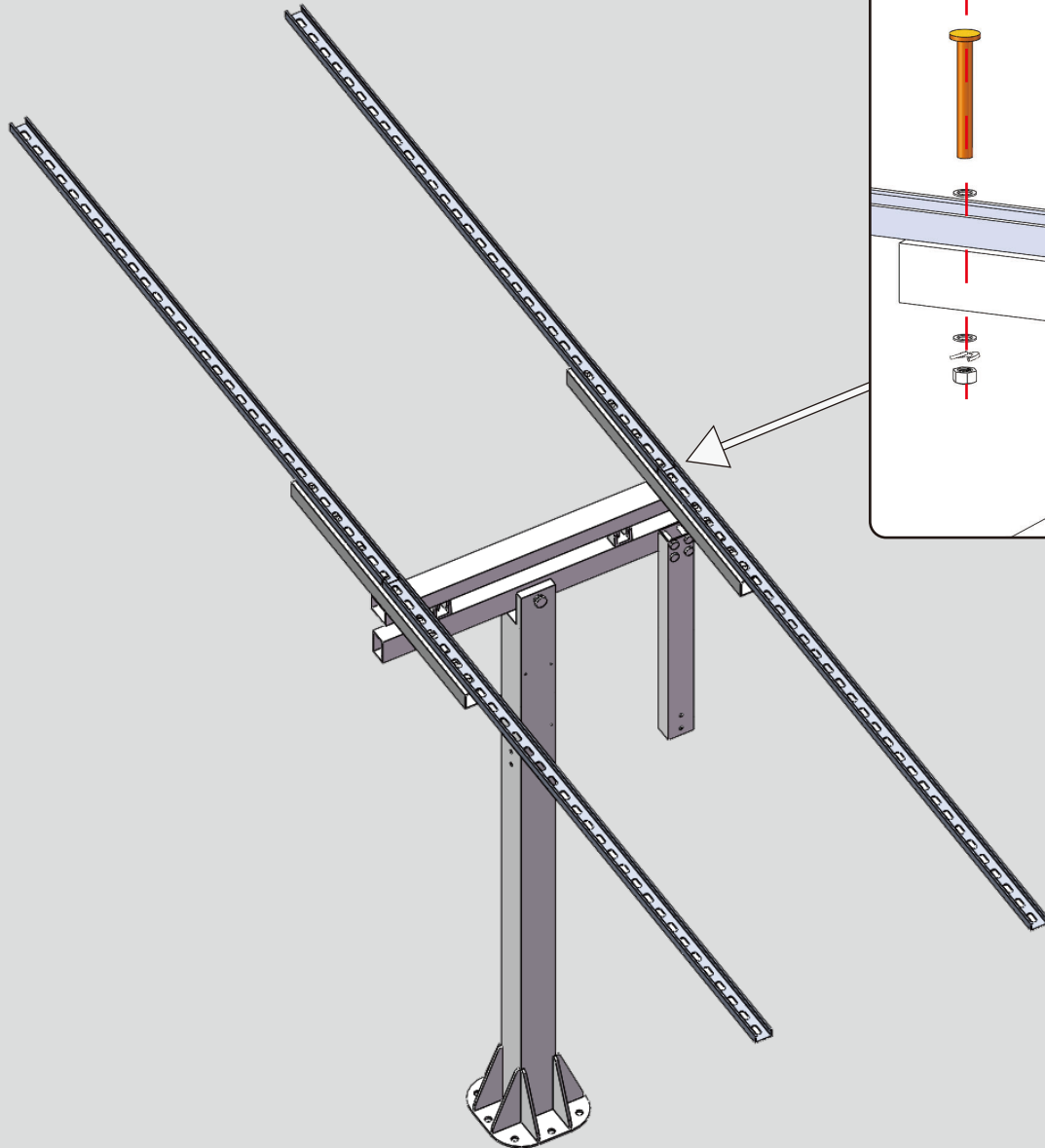

6

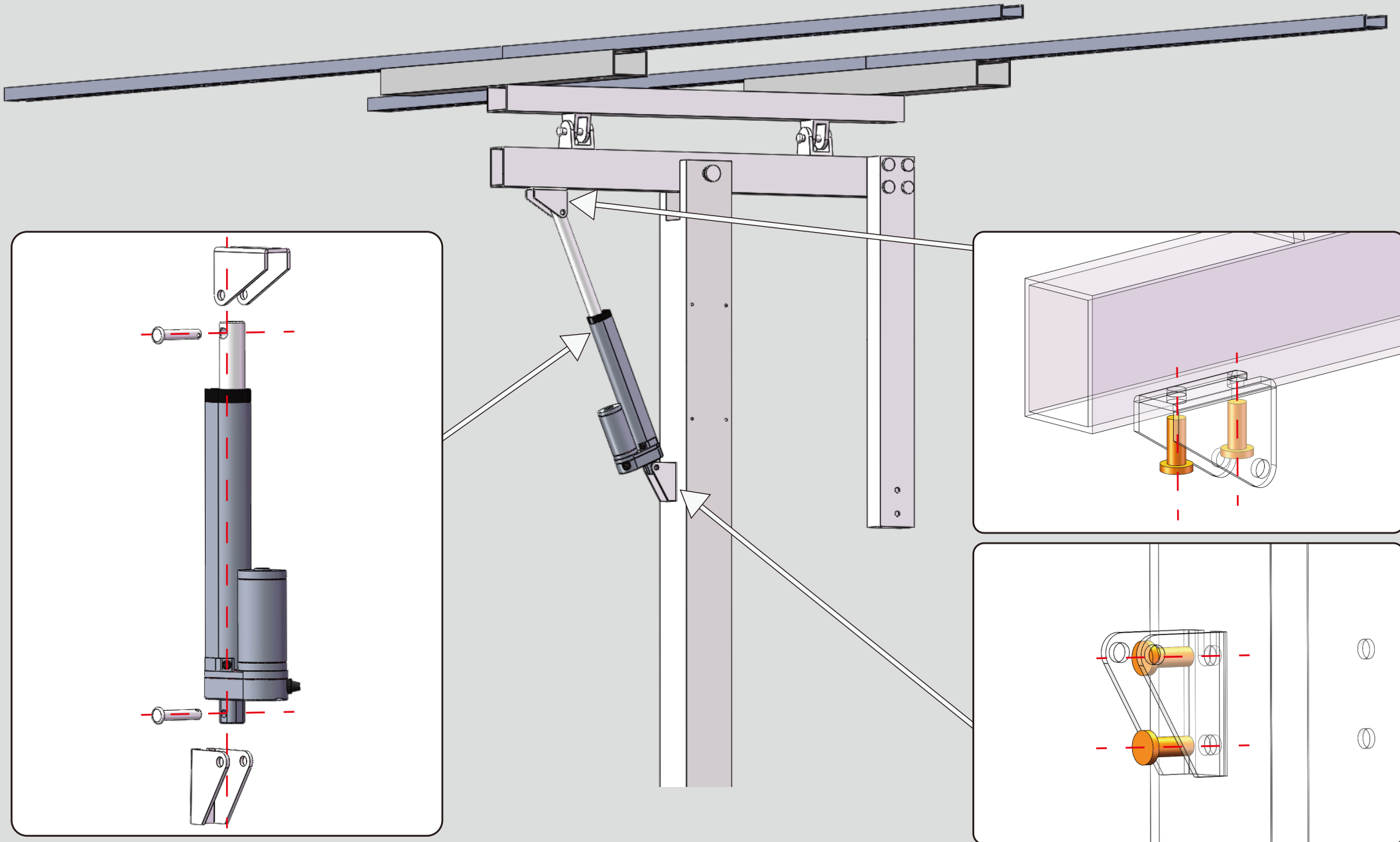

7



x1
300mm
Linear Actuator



x2
Linear Actuator
Stand



x4
M8*20
Socket Cap



x2
M6*30 Latch

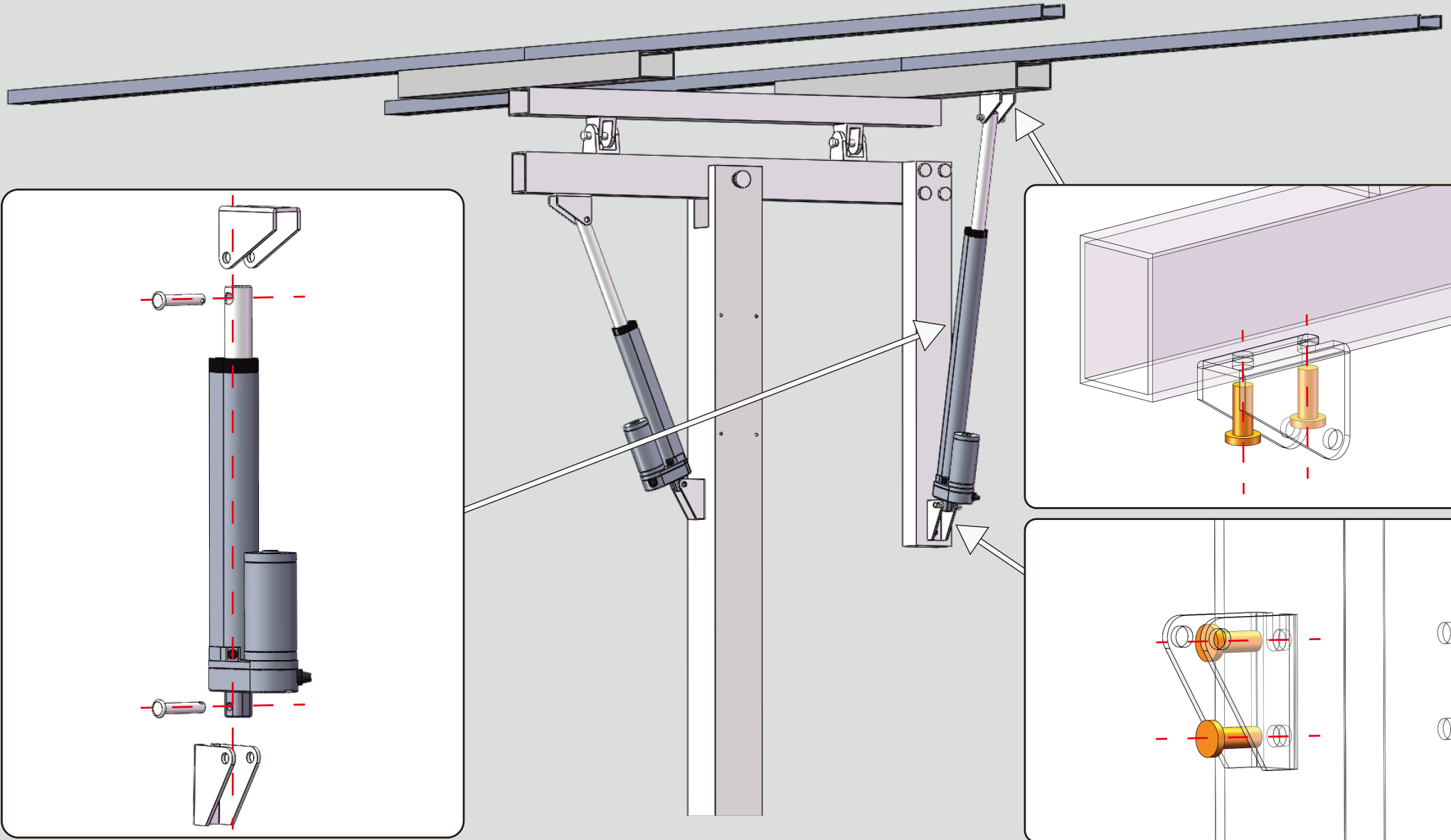

8

- x4** 1500mm Channel Steel
- x2** U-Shaped Connector
- x8** U-Shaped Locker
- x4** M10*70 Socket Cap
- x8** M10*20 Socket Cap
- x12** M10 Hex Nut
- x20** M10 Washer
- x12** Elastic Washer

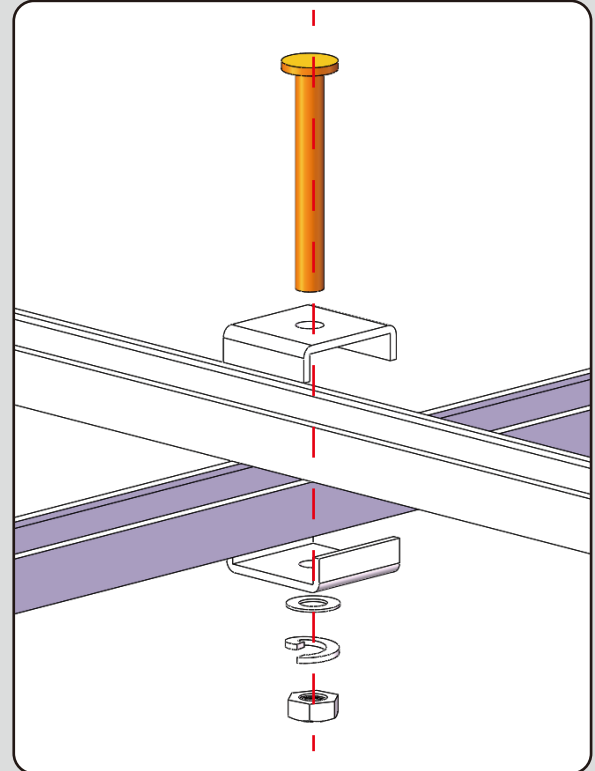
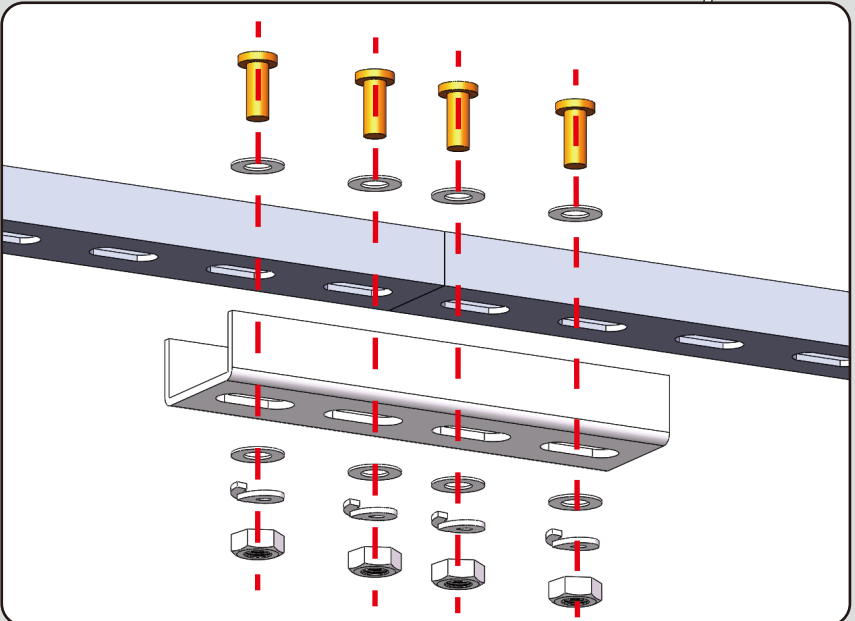
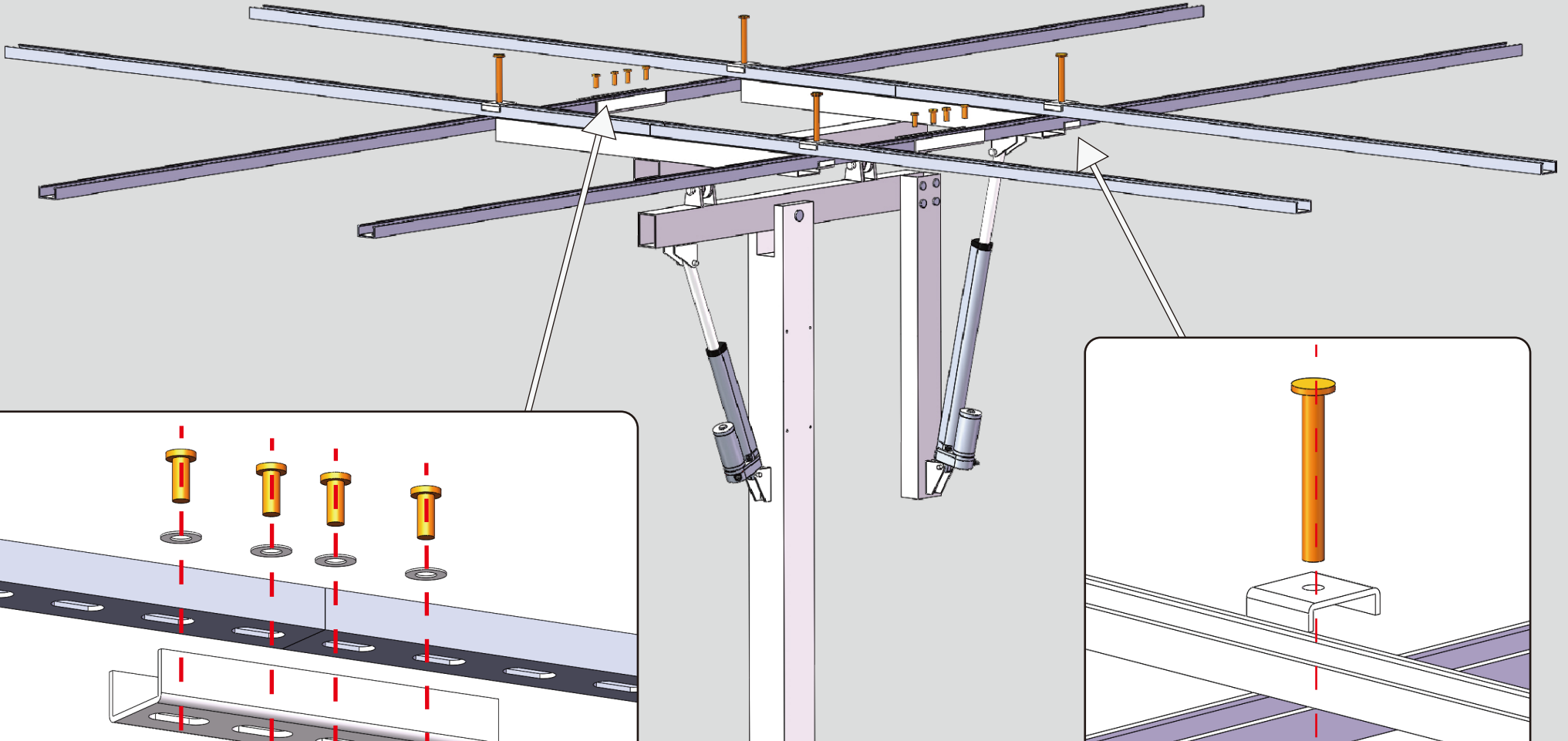

9



x12
Solar Panel
Side Clamp

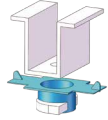

x6
Solar Panel
Middle Clamp



x18
M8*40
Socket Cap

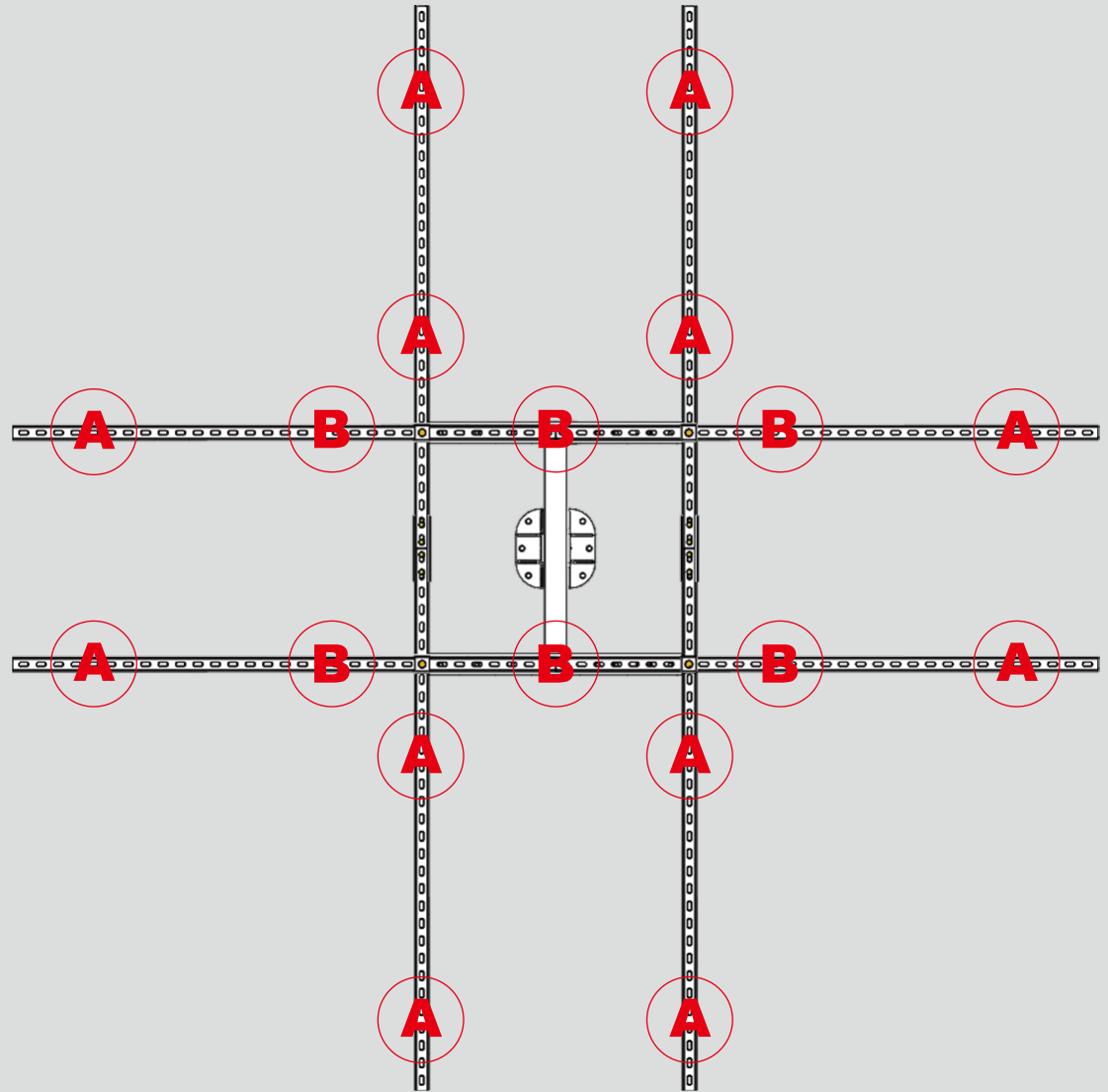
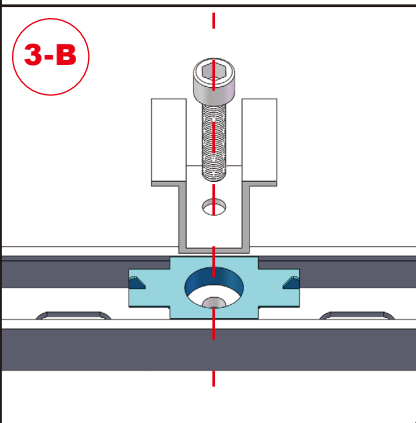
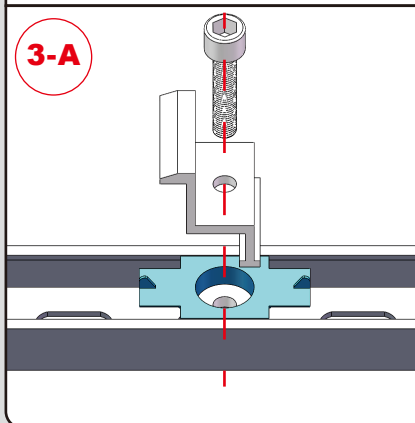
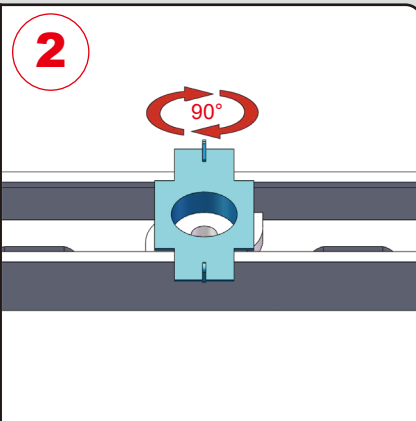
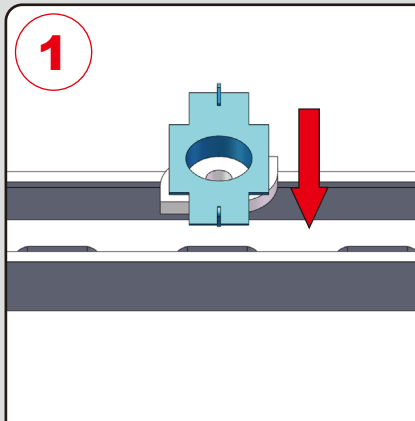
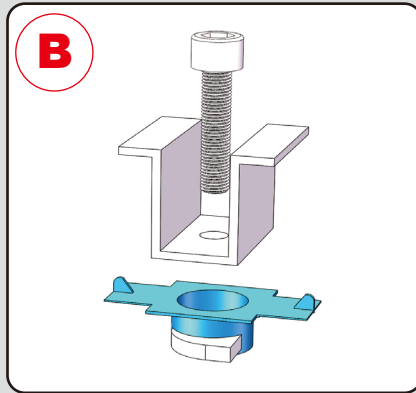
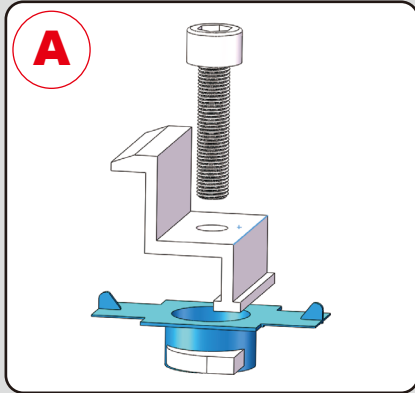

10



x1
Sunlight
Sensor

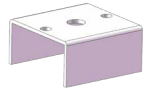

x1
Sunlight sensor
Stand



x2
M6*12
Hex Cap



x1
M10*40
Hex Cap



x2
Flange Nut



x1
M10
Hex Nut



x1
M10
Washer



x1
Elastic
Washer

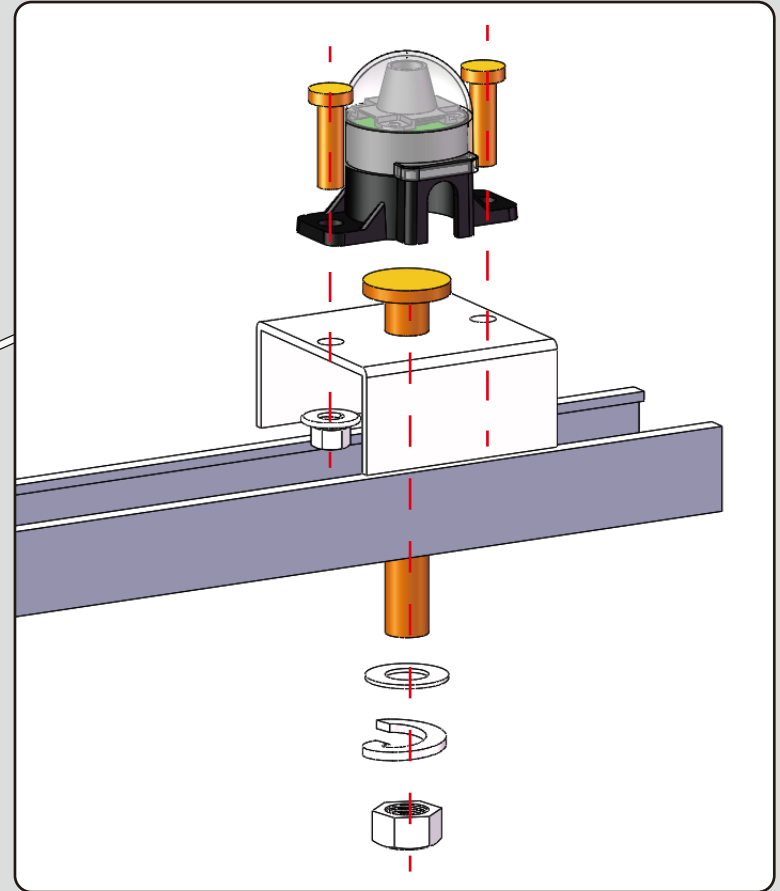
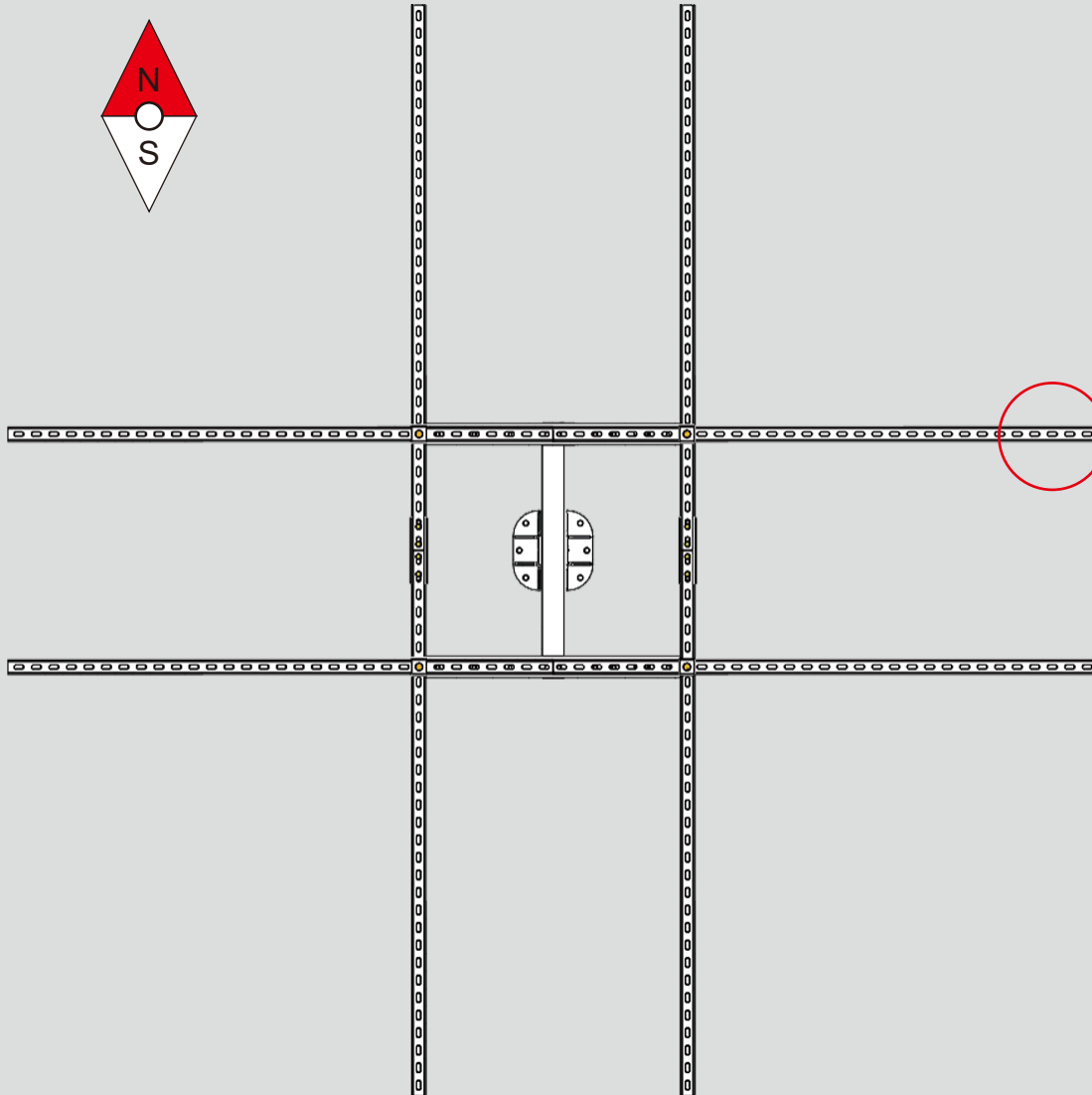

11

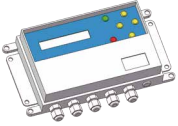

x1
Solar tracker
Controller



x4
M4*16
Hex Cap

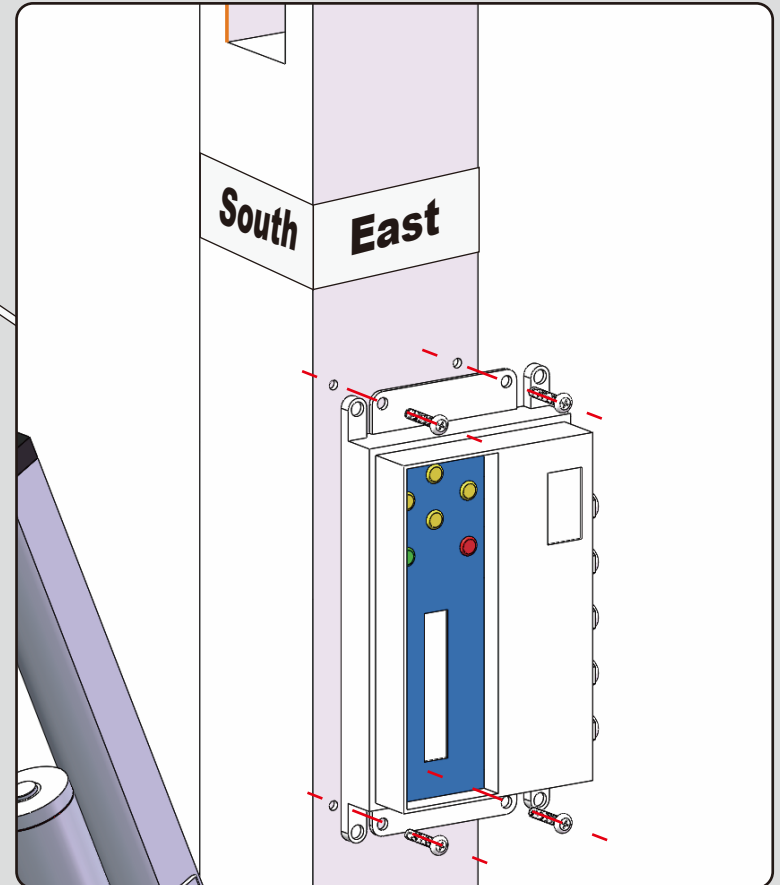
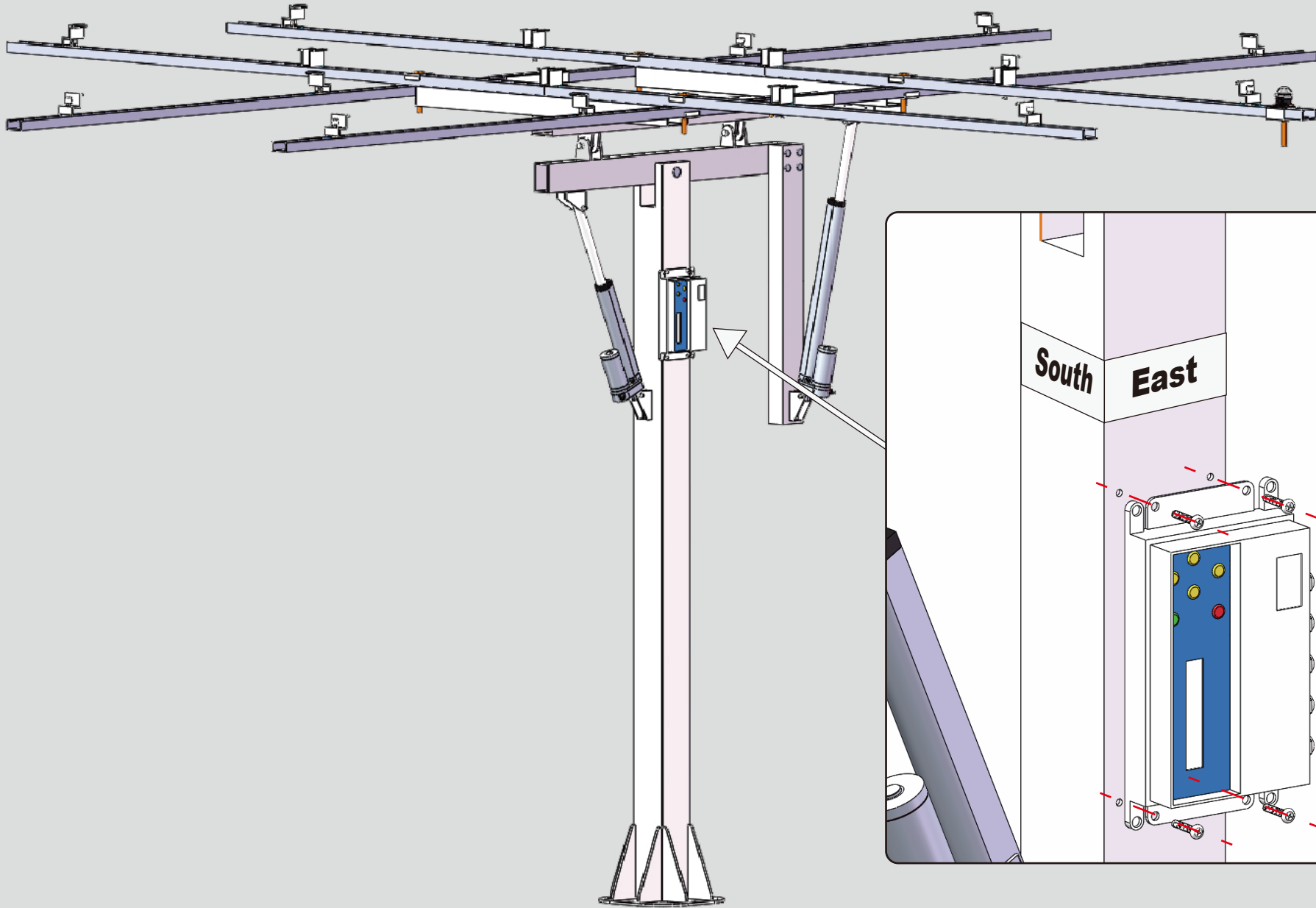

12

Solar Panel Sizing Formula: $L + 2W \leq 2800\text{mm}$

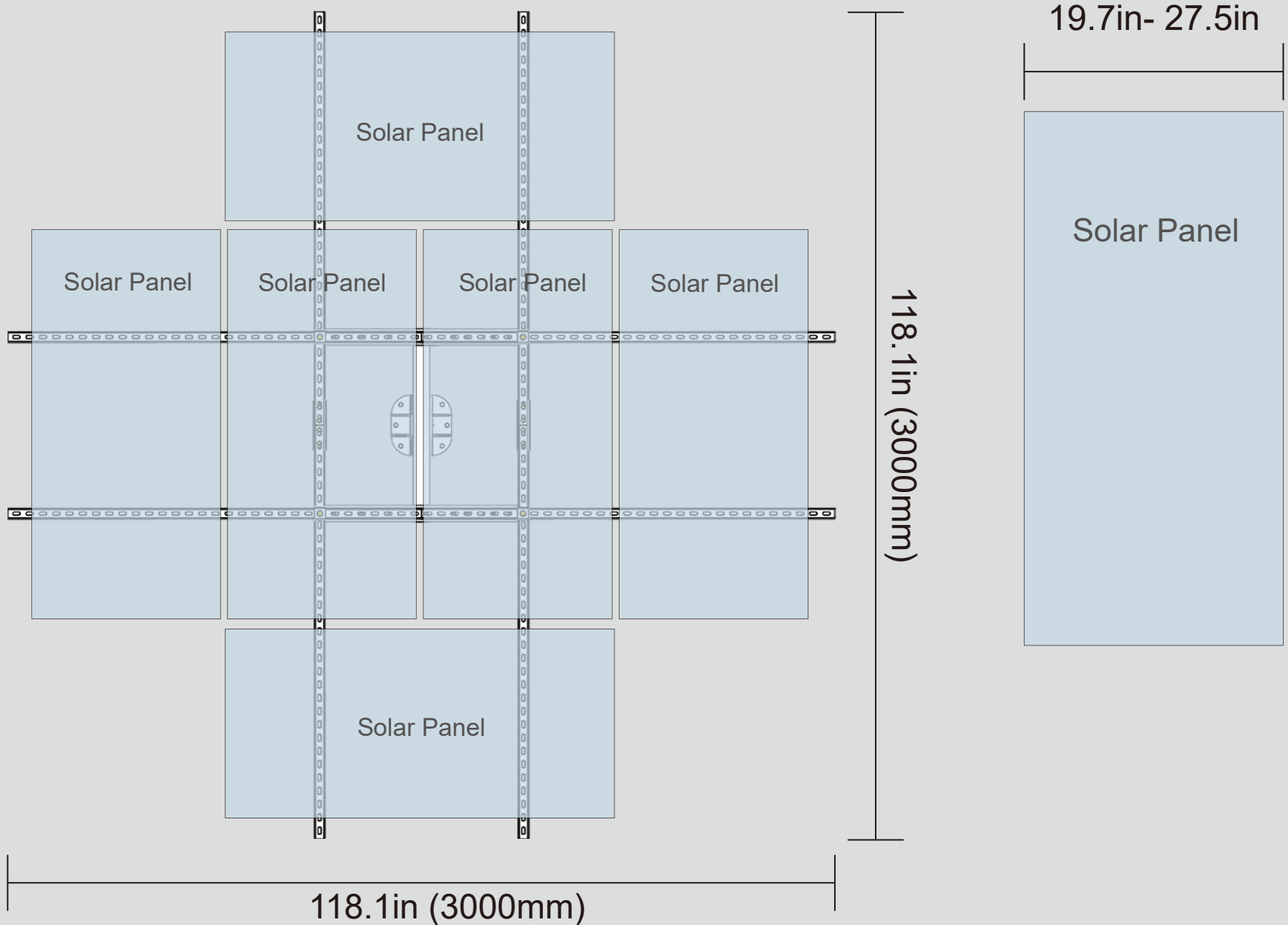

SUPPORT

- For the use of this manual and the conditions or methods of installation, operation, use, and maintenance of product are beyond ECO-WORTHY's control, ECO-WORTHY does not accept responsibility and expressly disclaims liability for any loss, damage, or expense arising out of or in any way connected with such installation, operation, use or maintenance.
- No responsibility is assumed by ECO-WORTHY for any infringement of patents or other rights of third parties, which may result from the use of the product.
- No license is granted by implication or otherwise under any patent or patent rights.
- The information in this manual is based on ECO-WORTHY's knowledge and experience and is believed to be reliable, but such information including product specification (without limitations) and suggestions do not constitute a warranty, expresses or implied.
- ECO-WORTHY reserves the right to change the manual, the products, the specifications, or product information sheets without prior notice.
- This product is covered by a 1 year warranty provided by ECO-WORTHY Ltd. We will refund or partial refund or replace any products with defects due to our imprudence. If you are experiencing technical problems and cannot find a solution in this manual, please contact ECO-WORTHY for further assistance.

Contact Number:

US: 1-866-939-8222

UK: +44 20 7570 0328

DE: +49 693-1090-113

Email:

customer.service@eco-worthy.com

Installation & Setting Video:





ECO-WORTHY

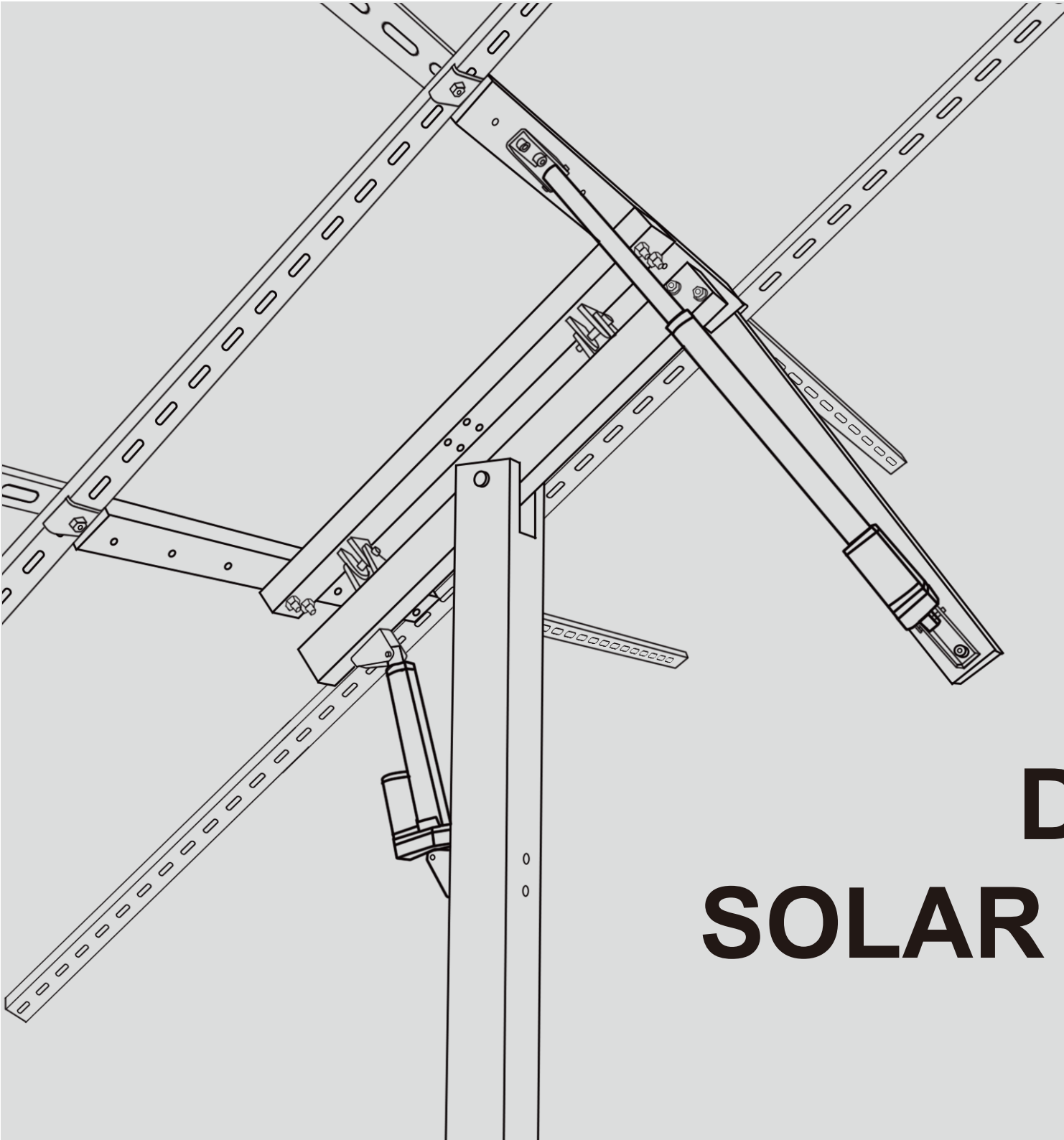

DUAL-AXIS SOLAR TRACKER

Handbuch

SICHERHEITSVORSICHTLICHE

BITTE LESEN SIE SORGFÄLTIG VOR VERFAHREN

- Für den ordnungsgemäßen Gebrauch und die Wartung dieses Produkts lesen Sie bitte sorgfältig und verstehen Sie diese Anleitung vor der Installation.
- Stellen Sie sicher, dass das Trackersystem auf einem festen Betonboden installiert ist, der stark genug ist, um das Gewicht aller Tracker und Sonnenkollektoren zu halten.
- Stellen Sie sicher, dass alle Schrauben und Muttern während der Installation fest angezogen sind.
- Um den Winkel der Solarmodule einzustellen, lösen Sie zuerst die seitlichen Klemmen und mittleren Klemmen und bewegen Sie dann die Module vorsichtig. Stellen Sie die Solarmodule NICHT gewaltsam ein.
- Während der Langzeitnutzung können einige Komponenten gelöst oder korrodiert werden. Bitte überprüfen Sie den Tracker aus Sicherheitsgründen regelmäßig.
- Bei stürmischem Wetter mit einer Windgeschwindigkeit über 17,2m/s ist es am besten, die Solarmodule zu entfernen, um Schäden an der Halterung zu vermeiden.

WAS IST IN DER BOX

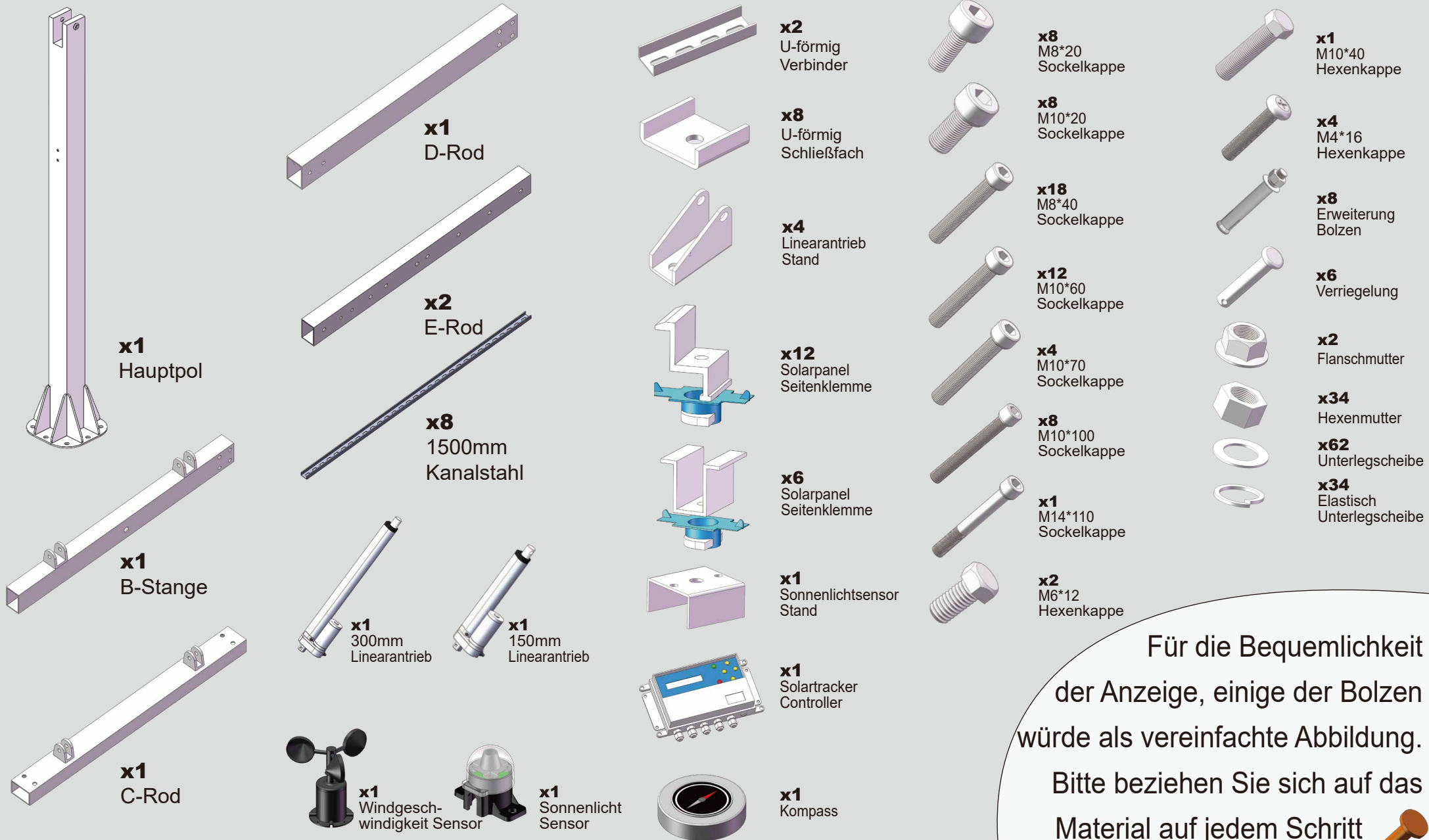

Für die Bequemlichkeit der Anzeige, einige der Bolzen würde als vereinfachte Abbildung. Bitte beziehen Sie sich auf das Material auf jedem Schritt



1

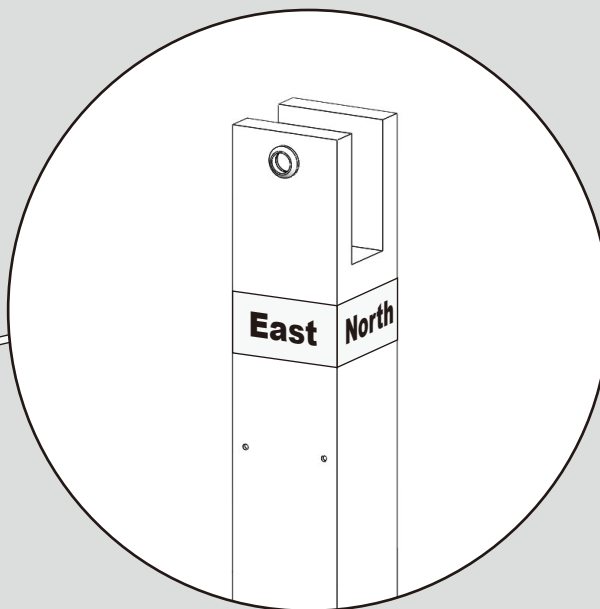
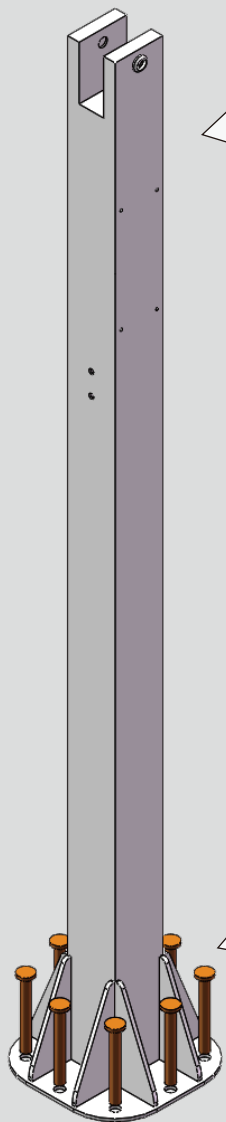

Es gibt vier Schilder am Hauptpol, die Richtungen anzeigen (Süd, Nord, West, Ost). Benutze den Kompass, um den Hauptstab kerngenau zu platzieren, damit der Tracker die Sonne richtig verfolgen kann.

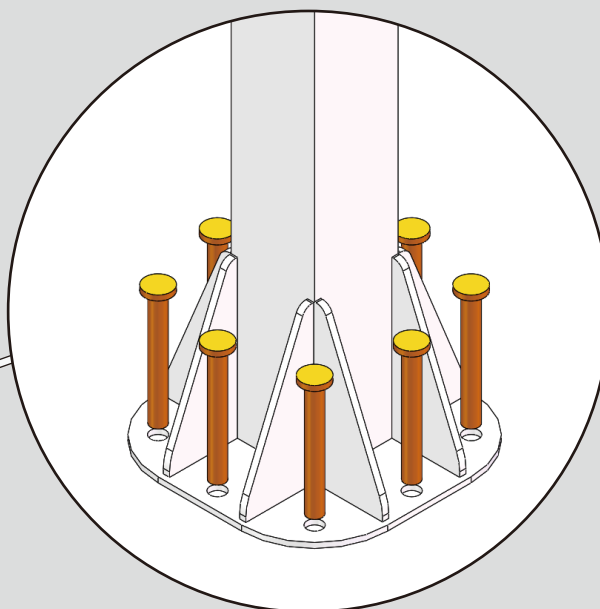

Der Hauptstab muss auf festem Betonboden oder Pier mit den Expansionschrauben installiert werden.

Der solide Boden muss größer oder gleich einem 600*600*700mm Würfel sein.

Betonmaterial empfehlen (kg/m³):
Zement(450kg)+Wasser(183kg)+Sand(600kg)
+Kies (1192kg)

2

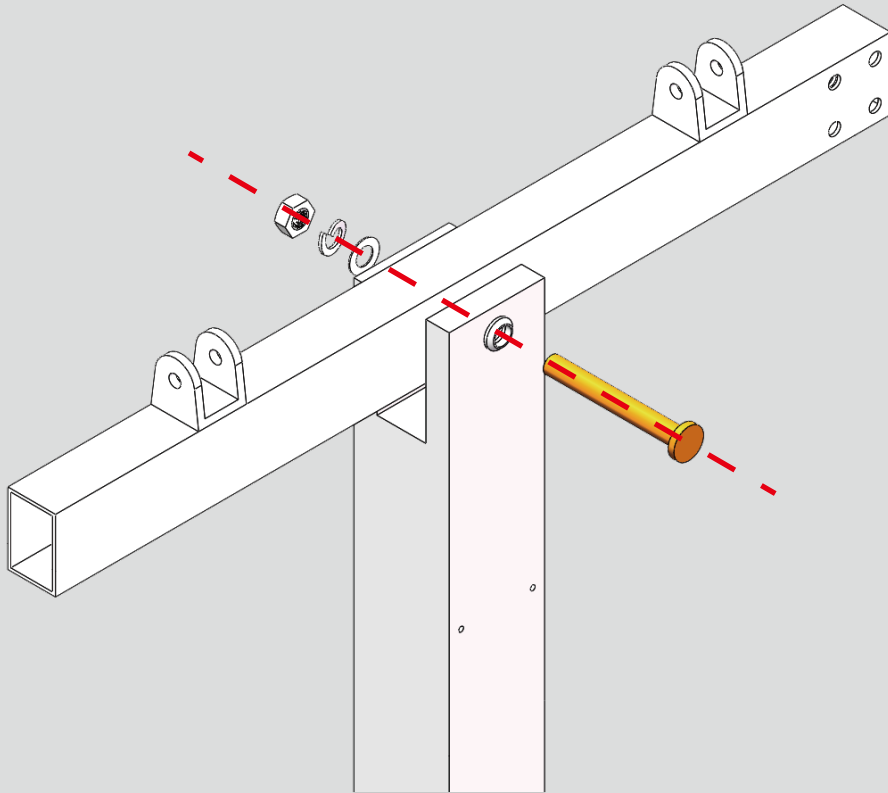
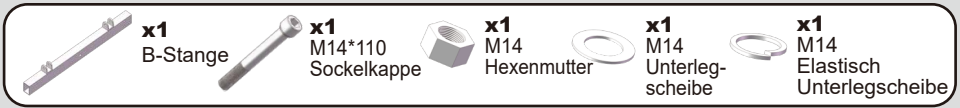

3

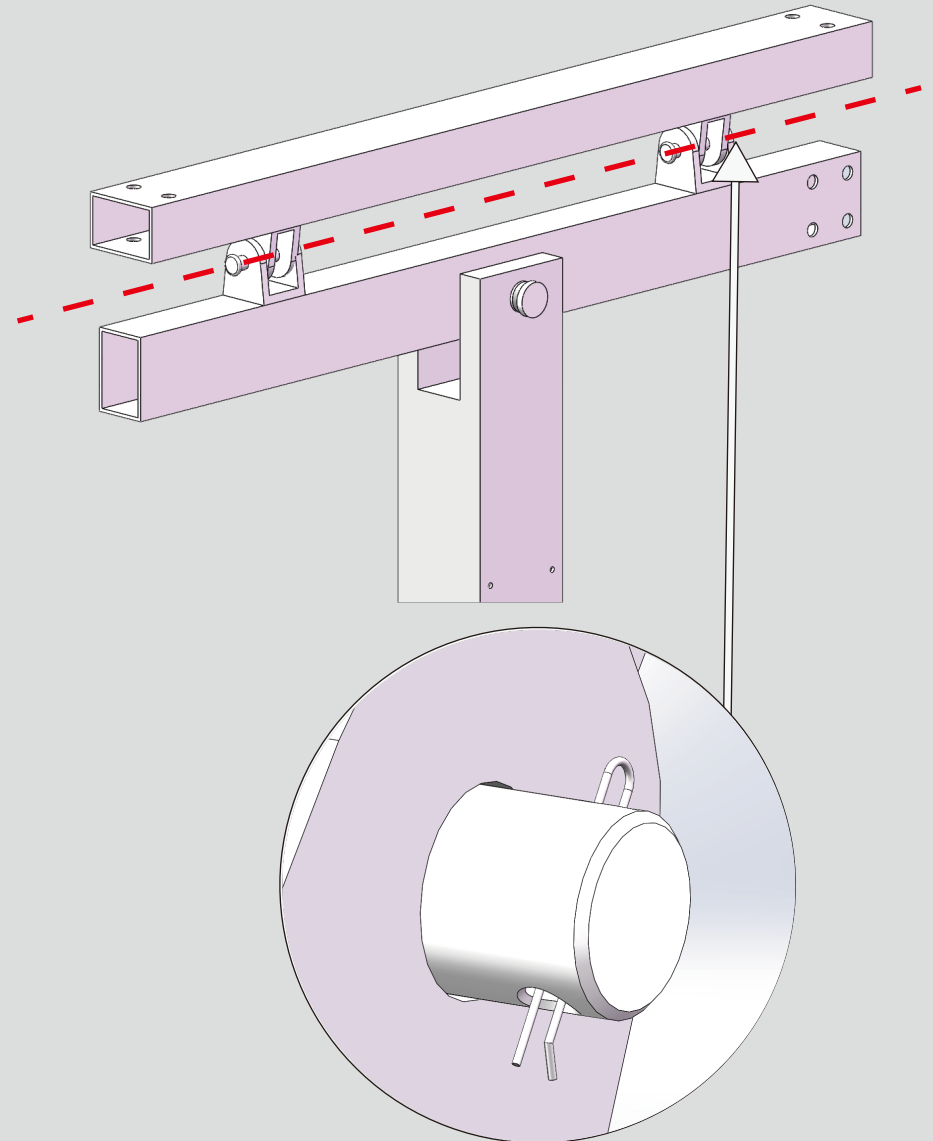

4

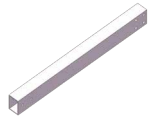

x1
D-Rod



x4
M10*100
Hexenkappe

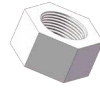

x4
M10
Nuss



x4
M10
Unterlegscheibe



x4
Elastisch
Unterlegscheibe

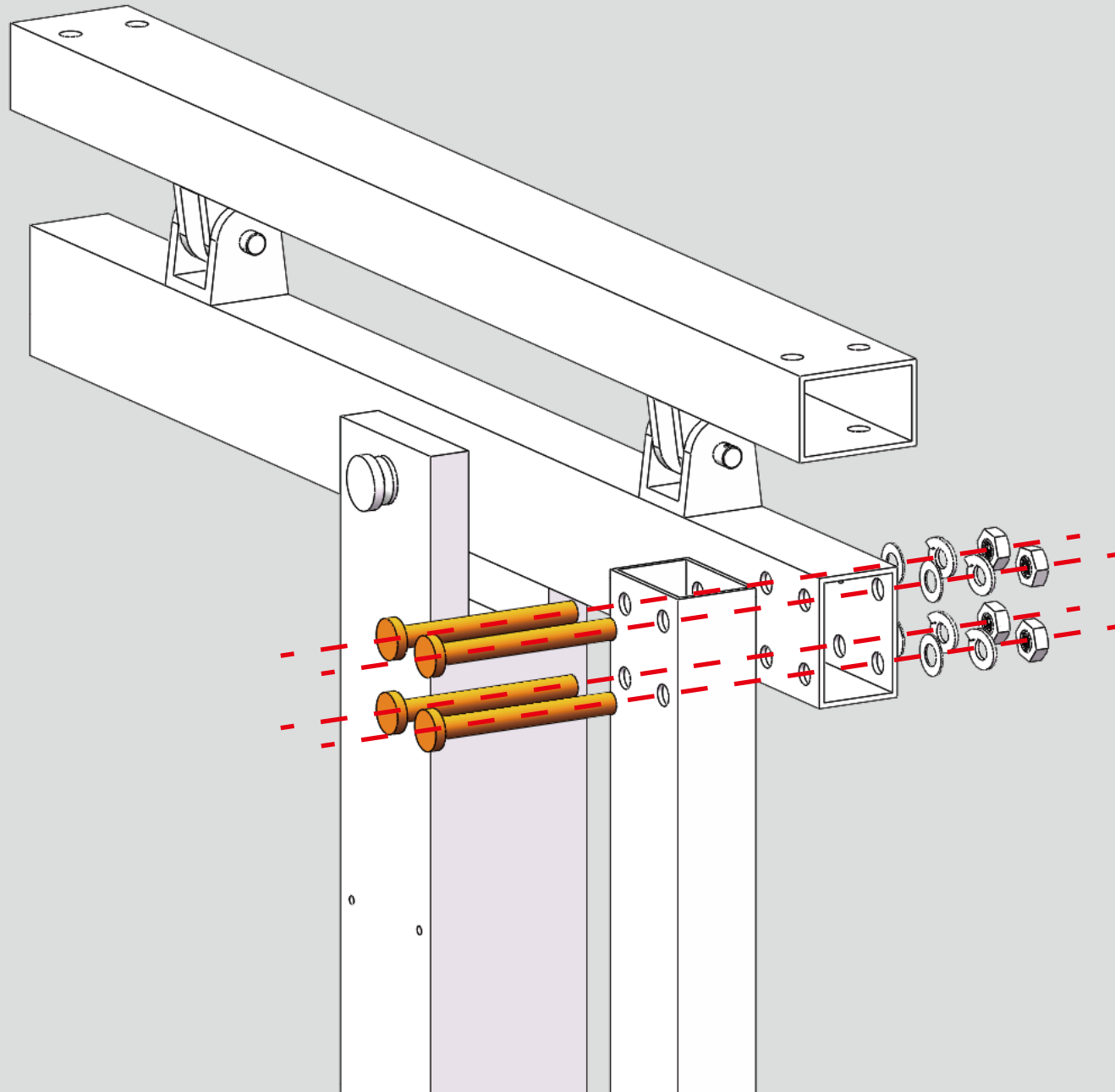

5

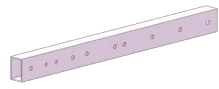

x2
E-Rod



x4
1500mm
Kanalstahl



x4
M10*100
Sockelkappe



x12
M10*60
Sockelkappe



x16
M10
Hexenmutter



x32
M10
Unterlegscheibe



x16
Elastisch
Unterlegscheibe

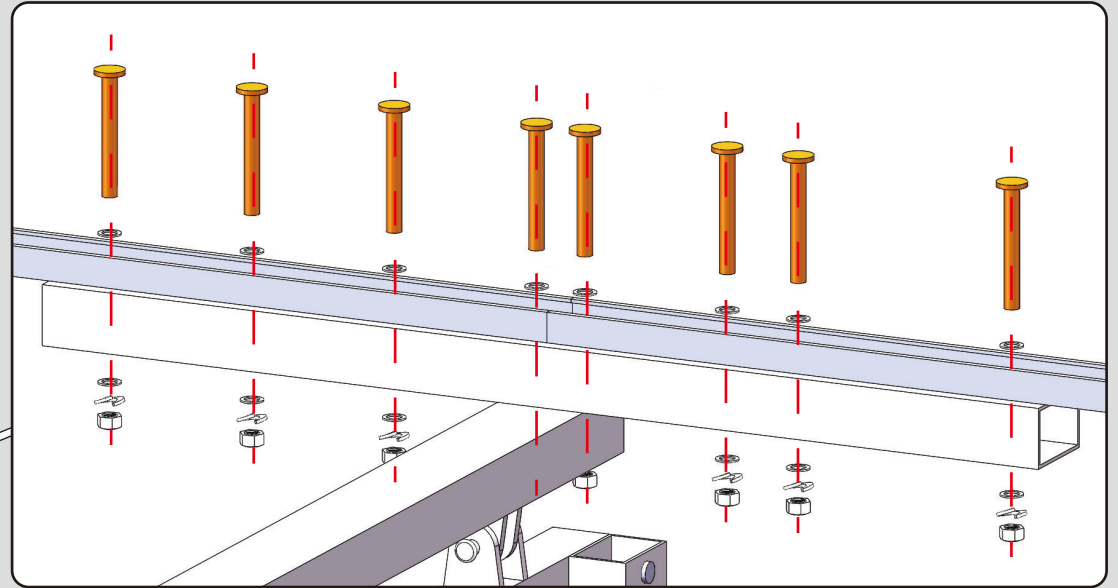
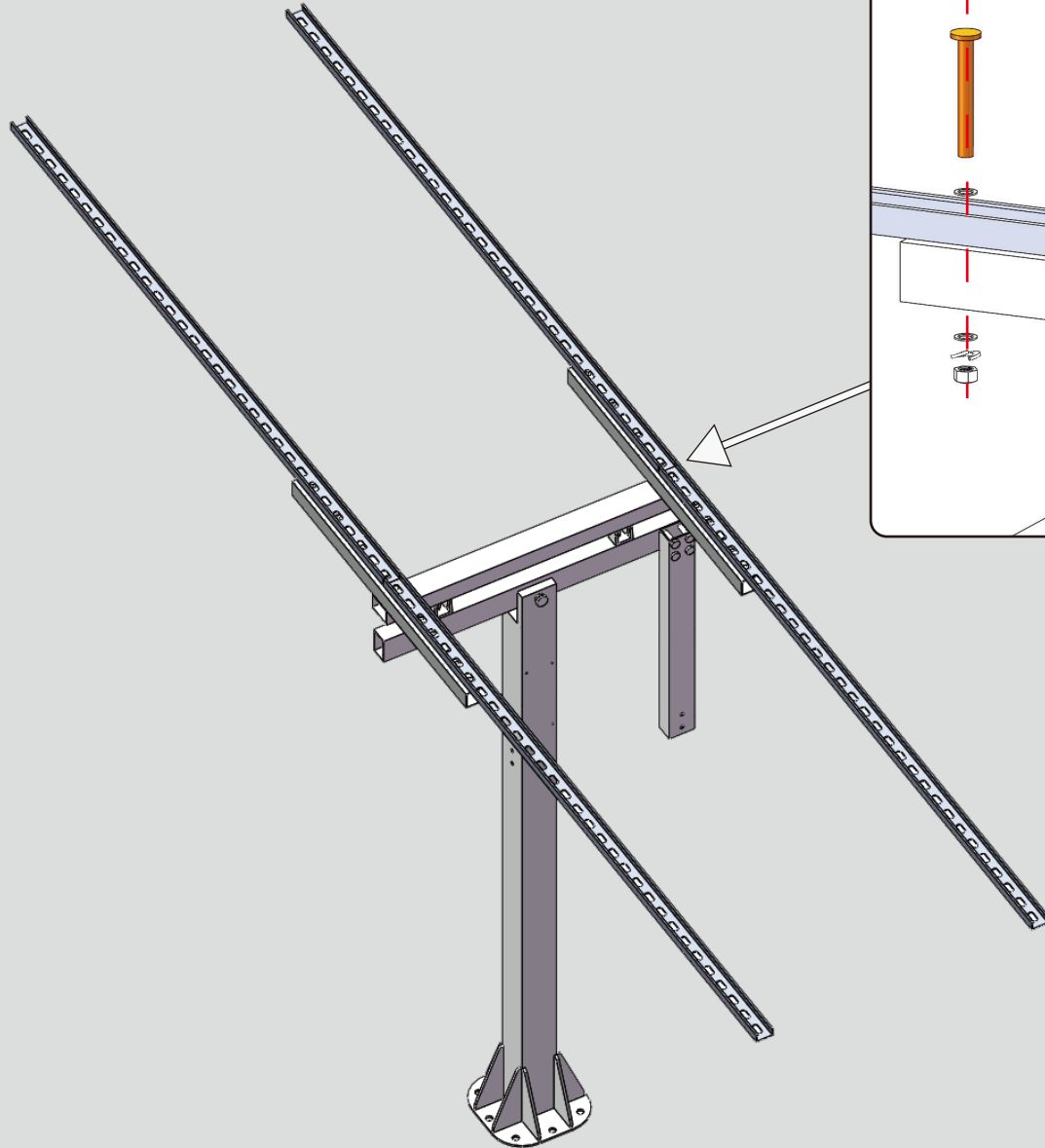

6

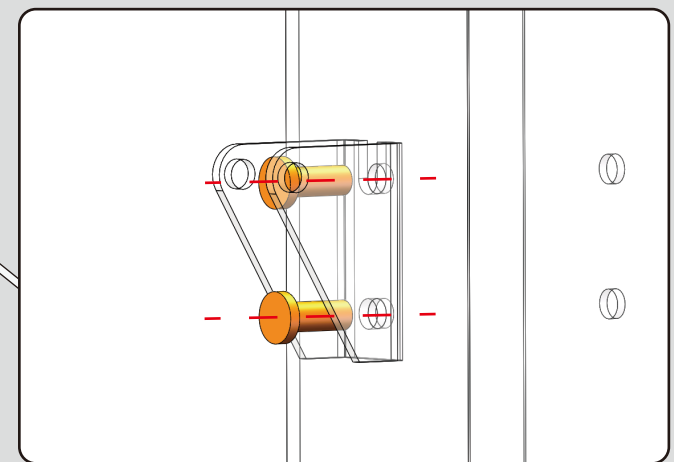
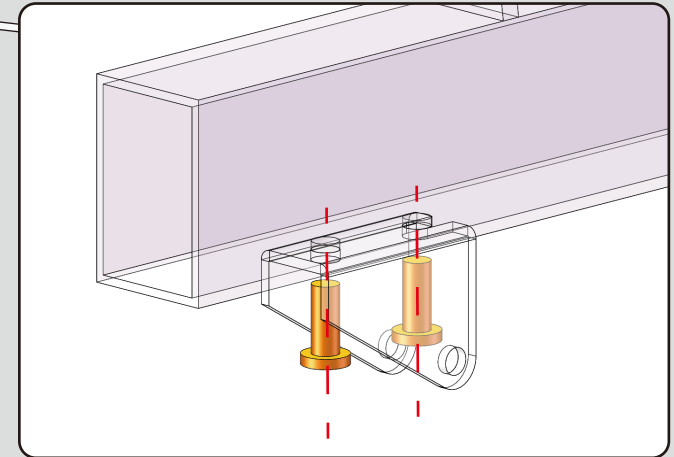
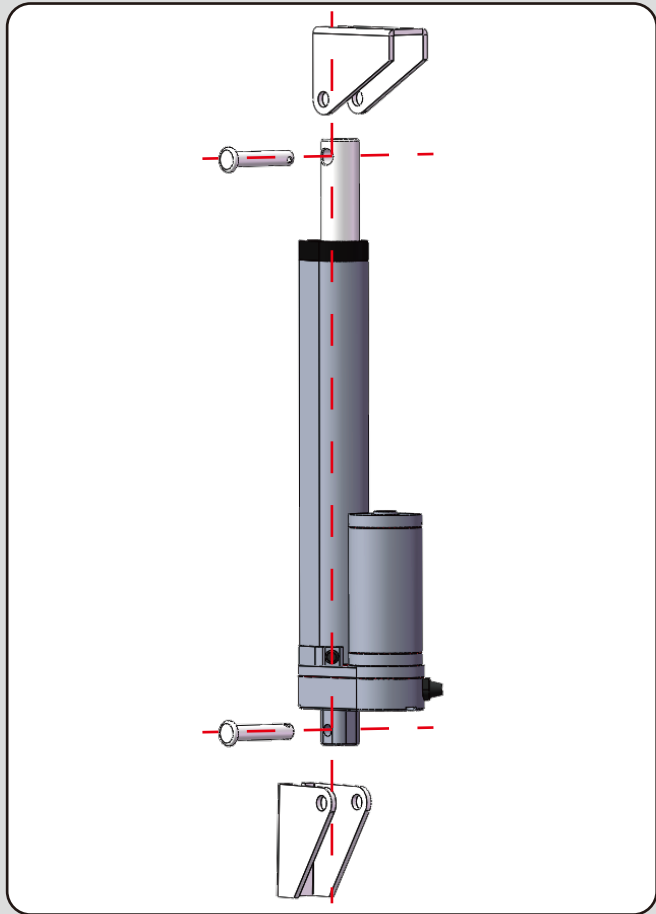
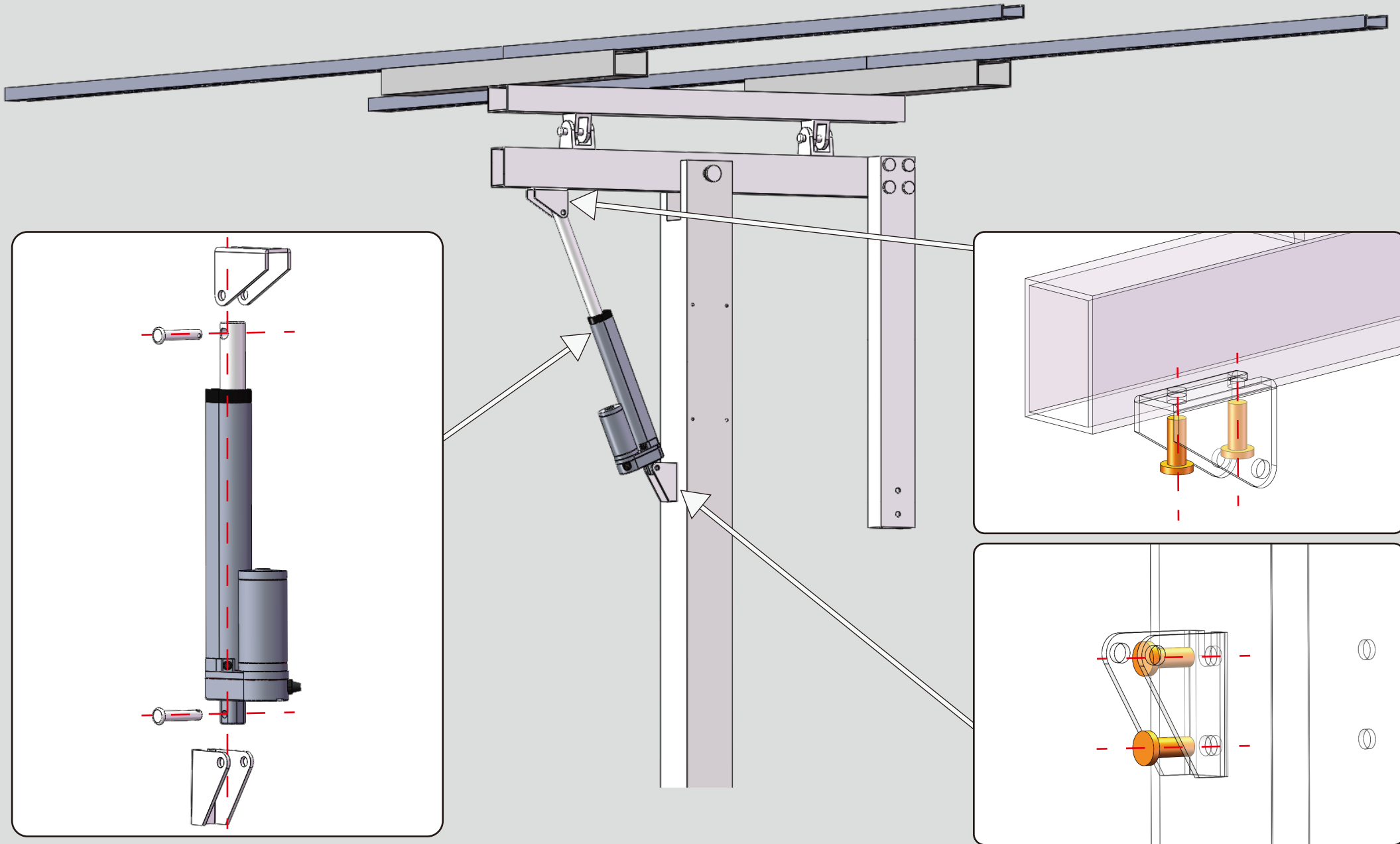

7



x1
300mm
Linearantrieb



x2
Linearantrieb
Stand



x4
M8*20
Sockelkappe



x2
M6*30
Verriegelung

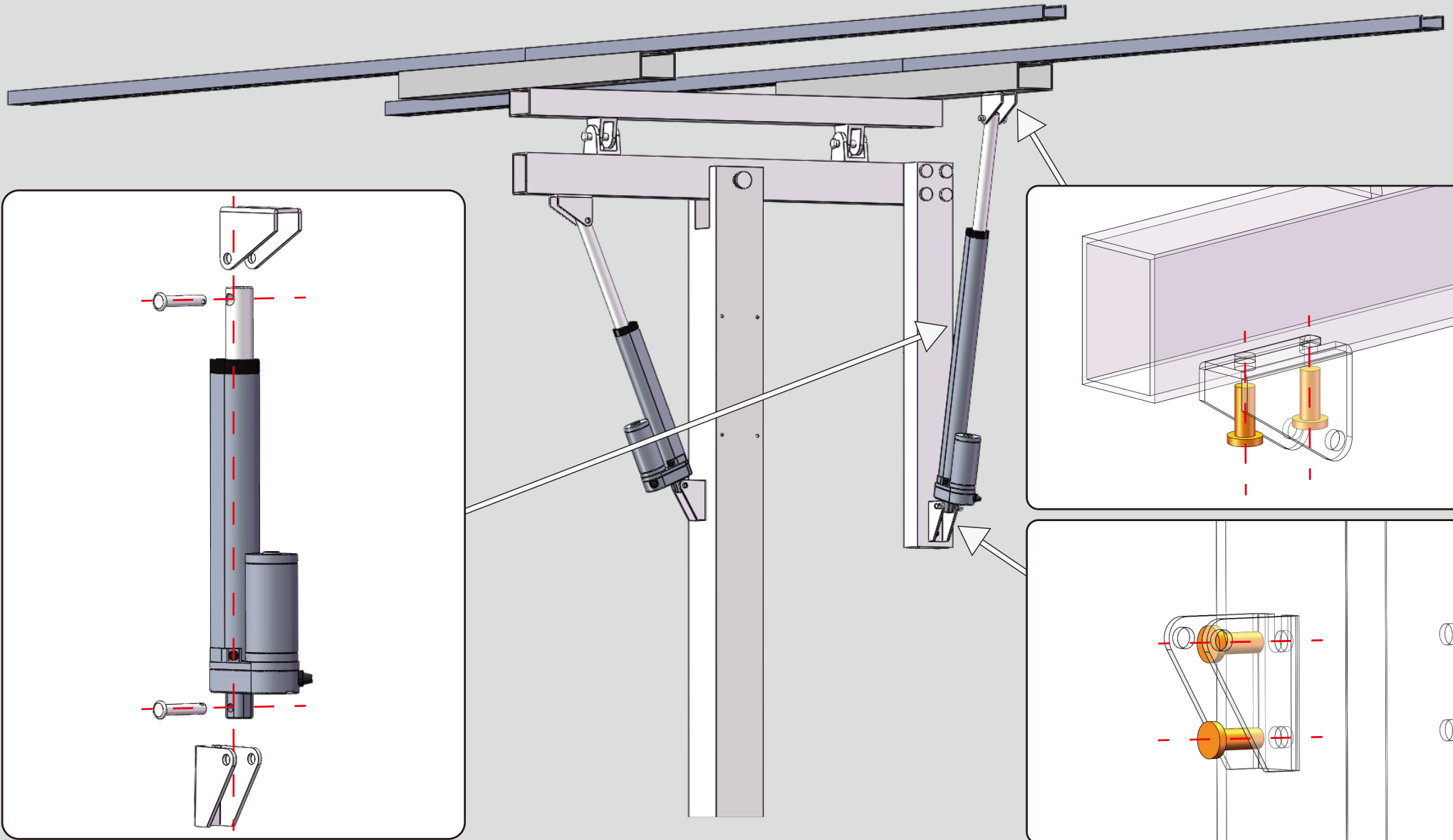

8

x4
1500mm
Kanalstahl

x2
U-förmig
Verbinder

x8
U-förmig
Schließfach

x4
M10*70
Sockelkappe

x8
M10*20
Sockelkappe

x12
M10
Hexenmutter

x20
M10
Unterlegscheibe

x12
Elastisch
Unterlegscheibe

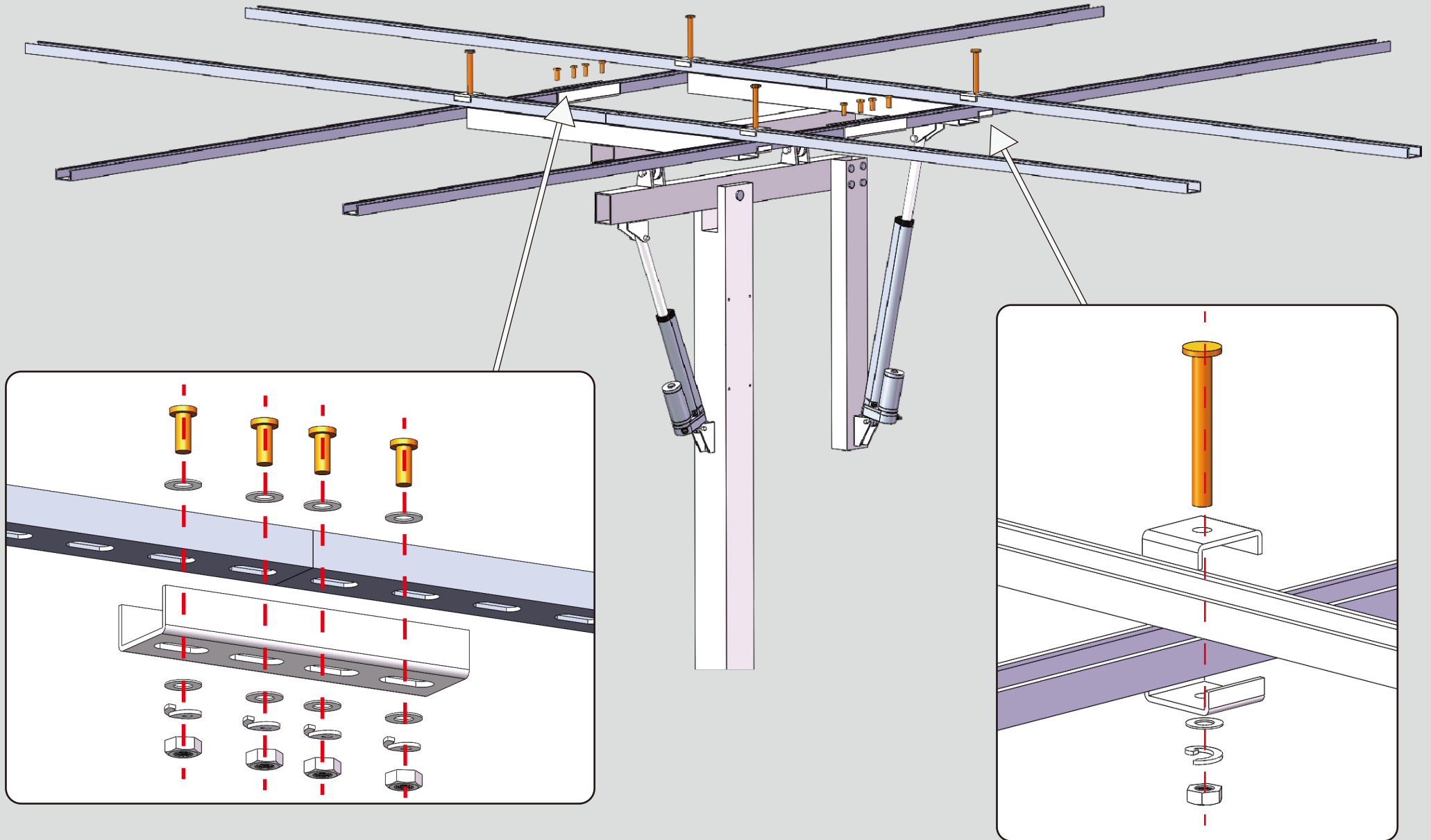

9



x12
Solarpanel
Seitenklemme

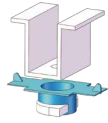

x6
Solarpanel
Mittelklemme



x18
M8*40
Sockelkappe

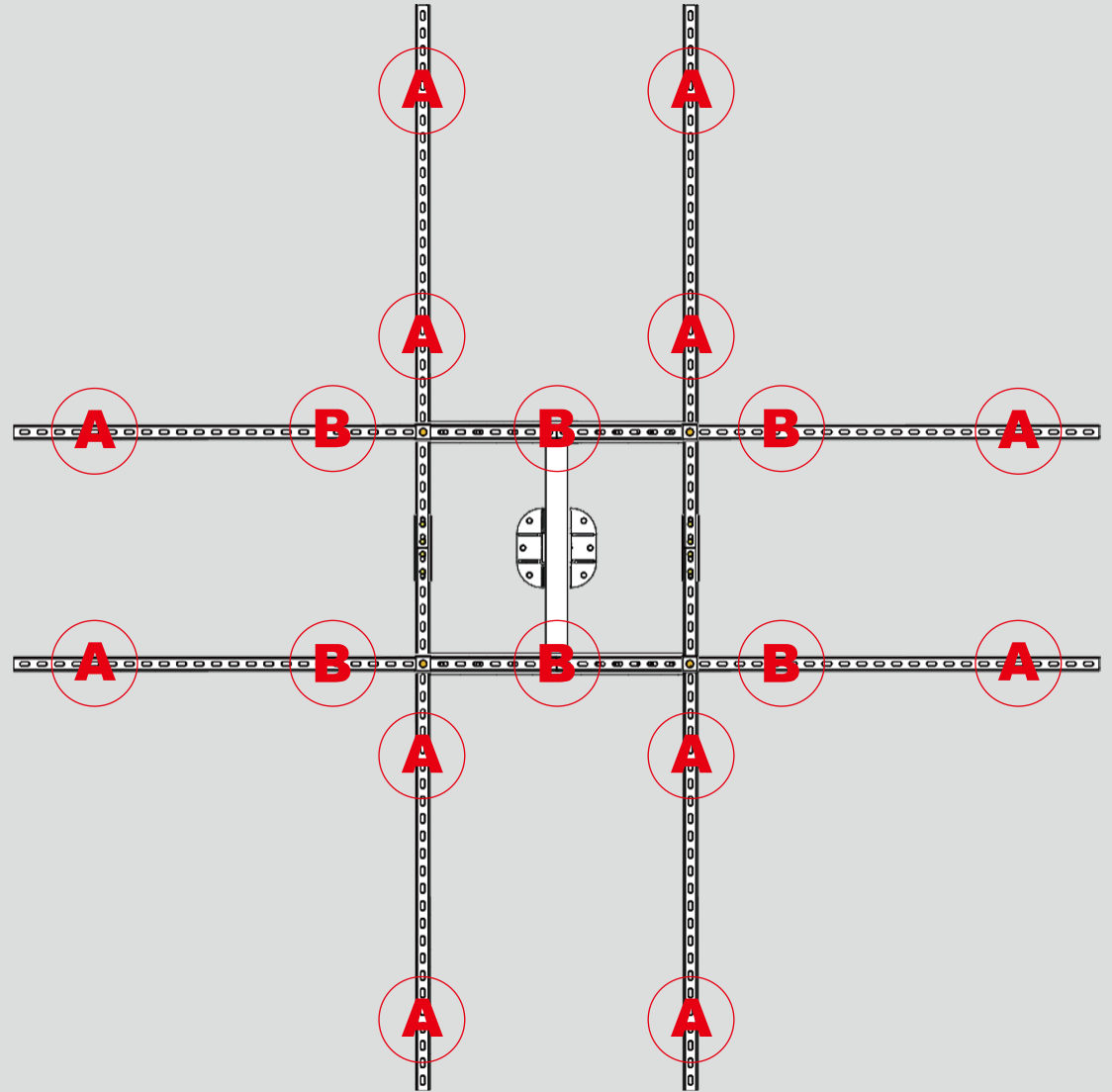
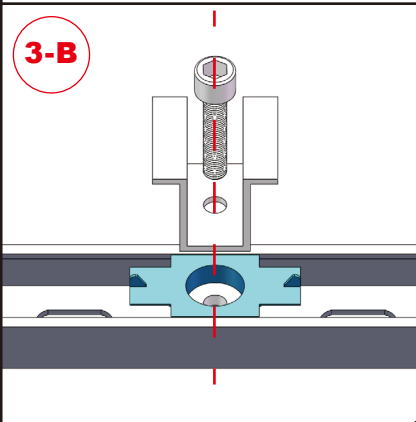
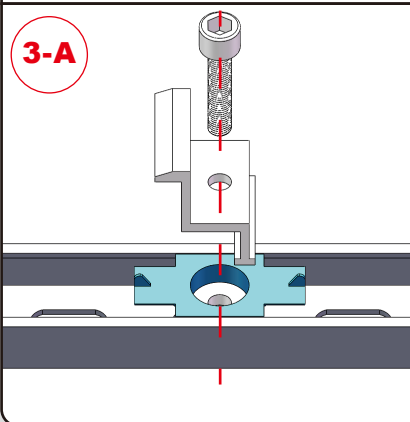
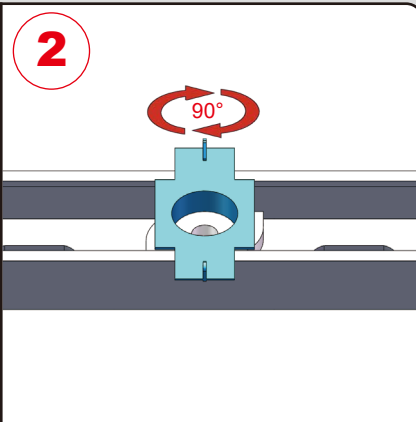
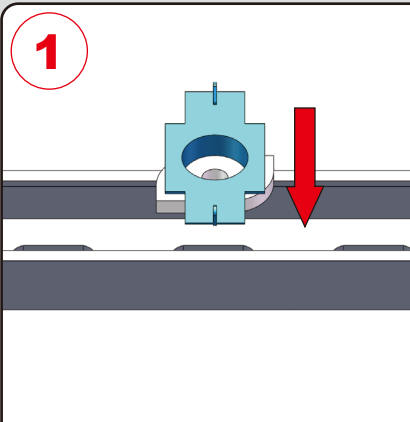
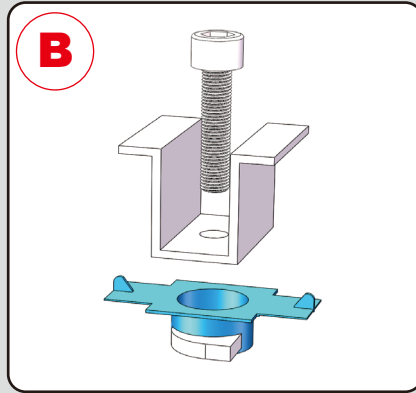
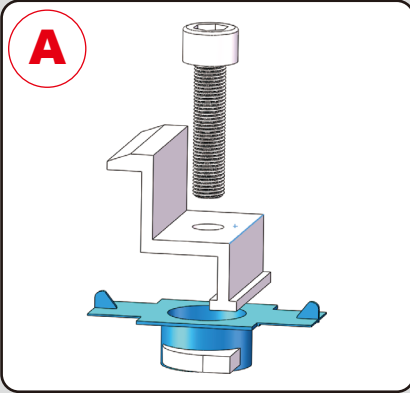

10



x1
Sonnenlicht
Sensor

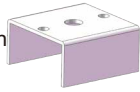

x1
Sonnenlichtsensor
Stand



x2
M6*12
Hexen-
kappe



x1
M10*40
Hexen-
kappe



x2
Flansch-
mutter



x1
M10
Hexenmutter



x1
M10
Unterlegs-
scheibe



x1
Elastisch
Unterlegscheibe

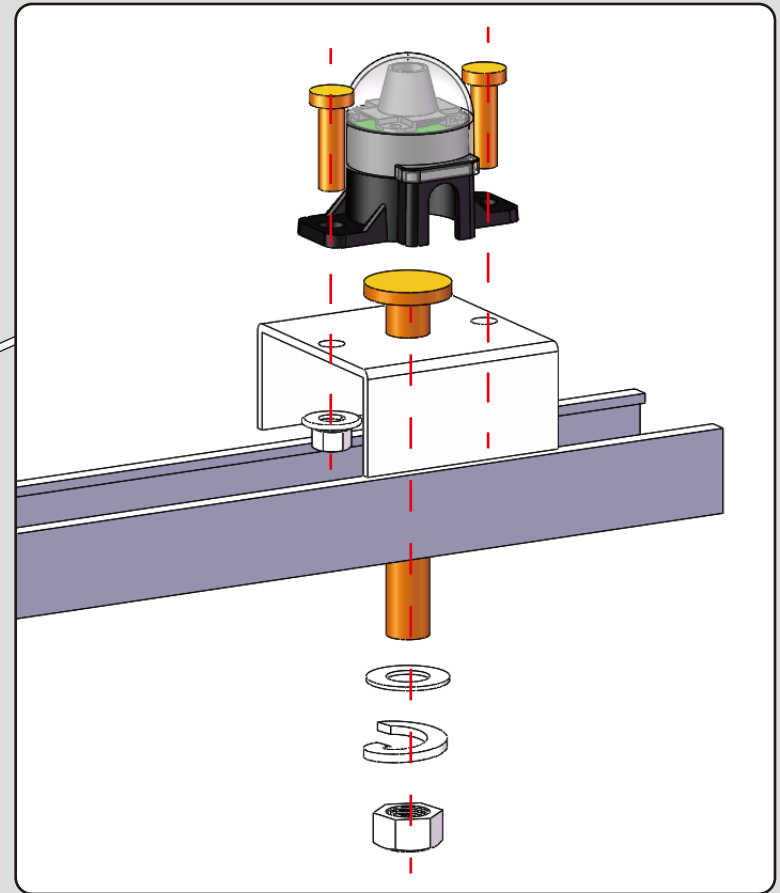
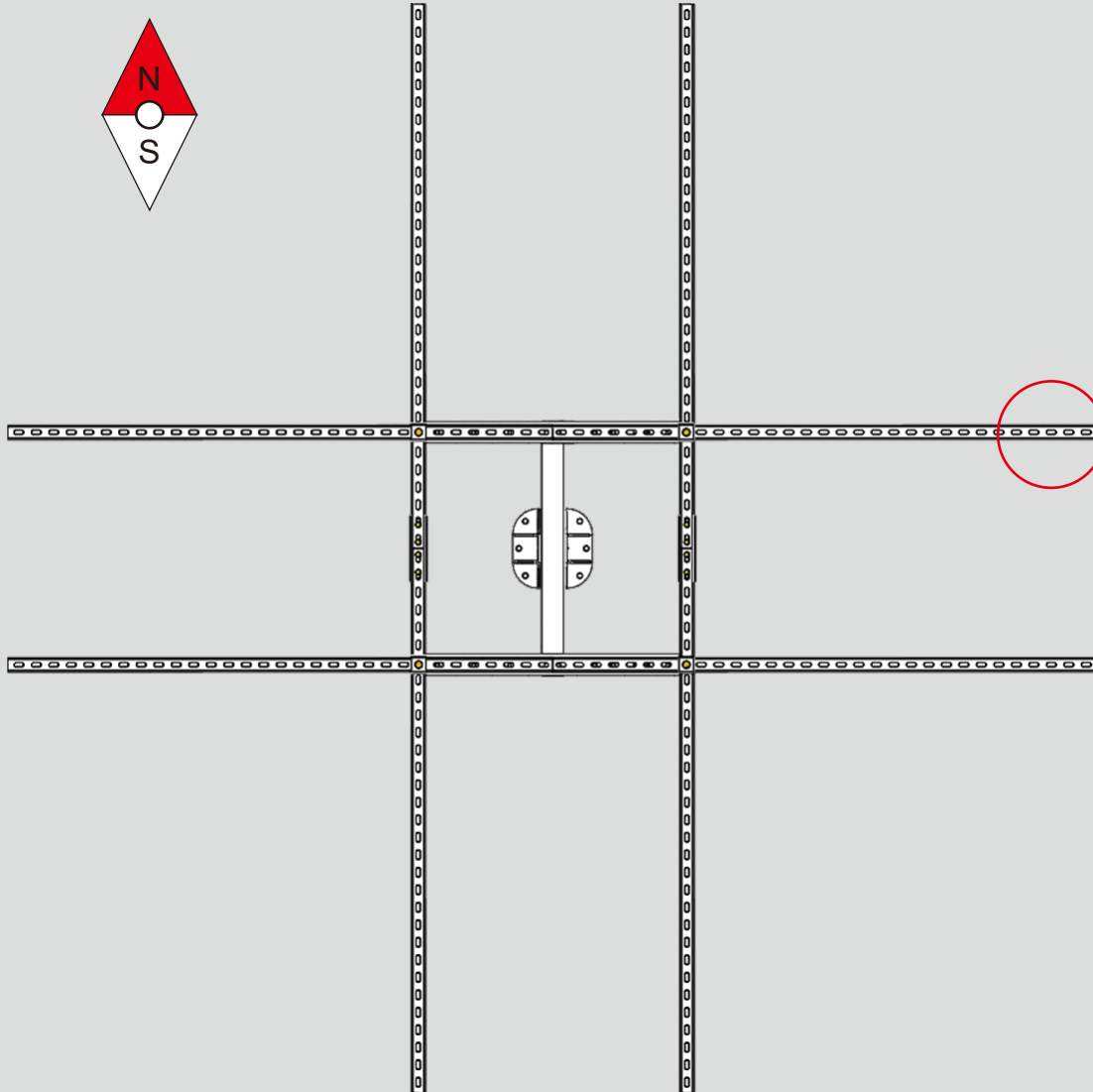

11

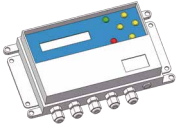

x1
Solartracker
Controller



x4
M4*16
Hexenkappe

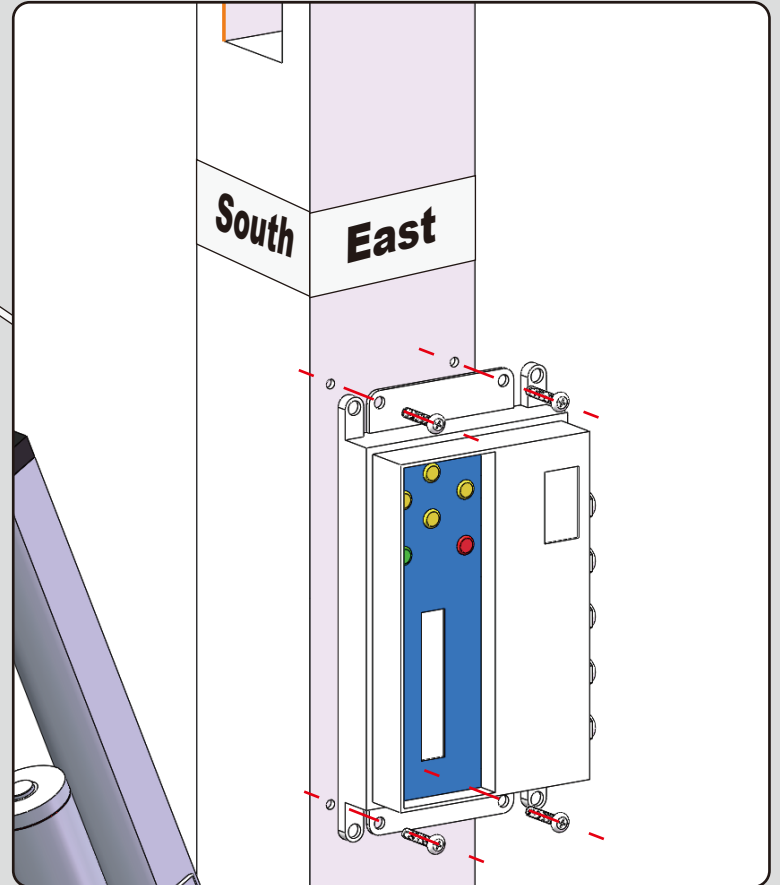
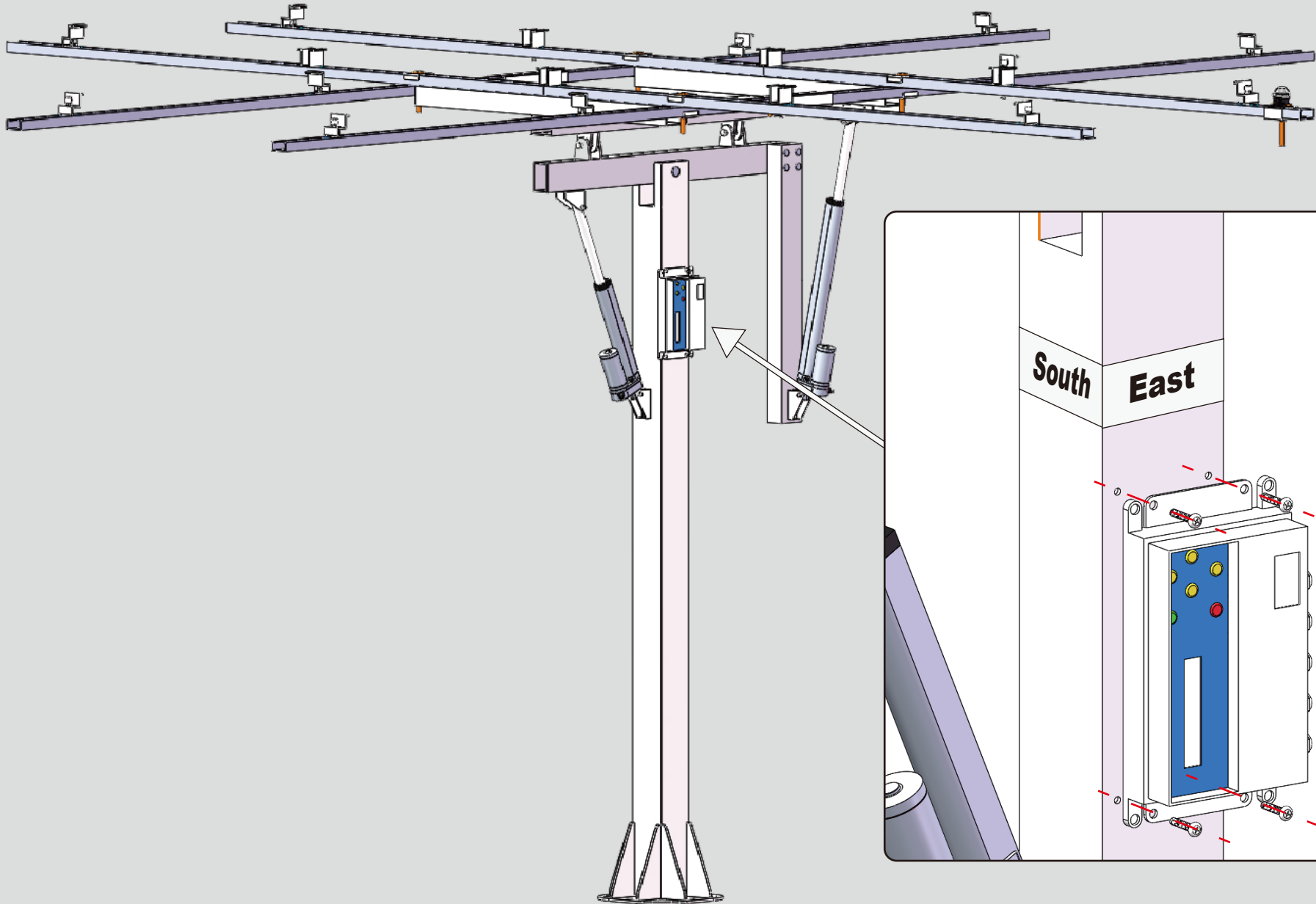

12

Solarpanel Größe Formel: $L+2W \leq 2800\text{mm}$

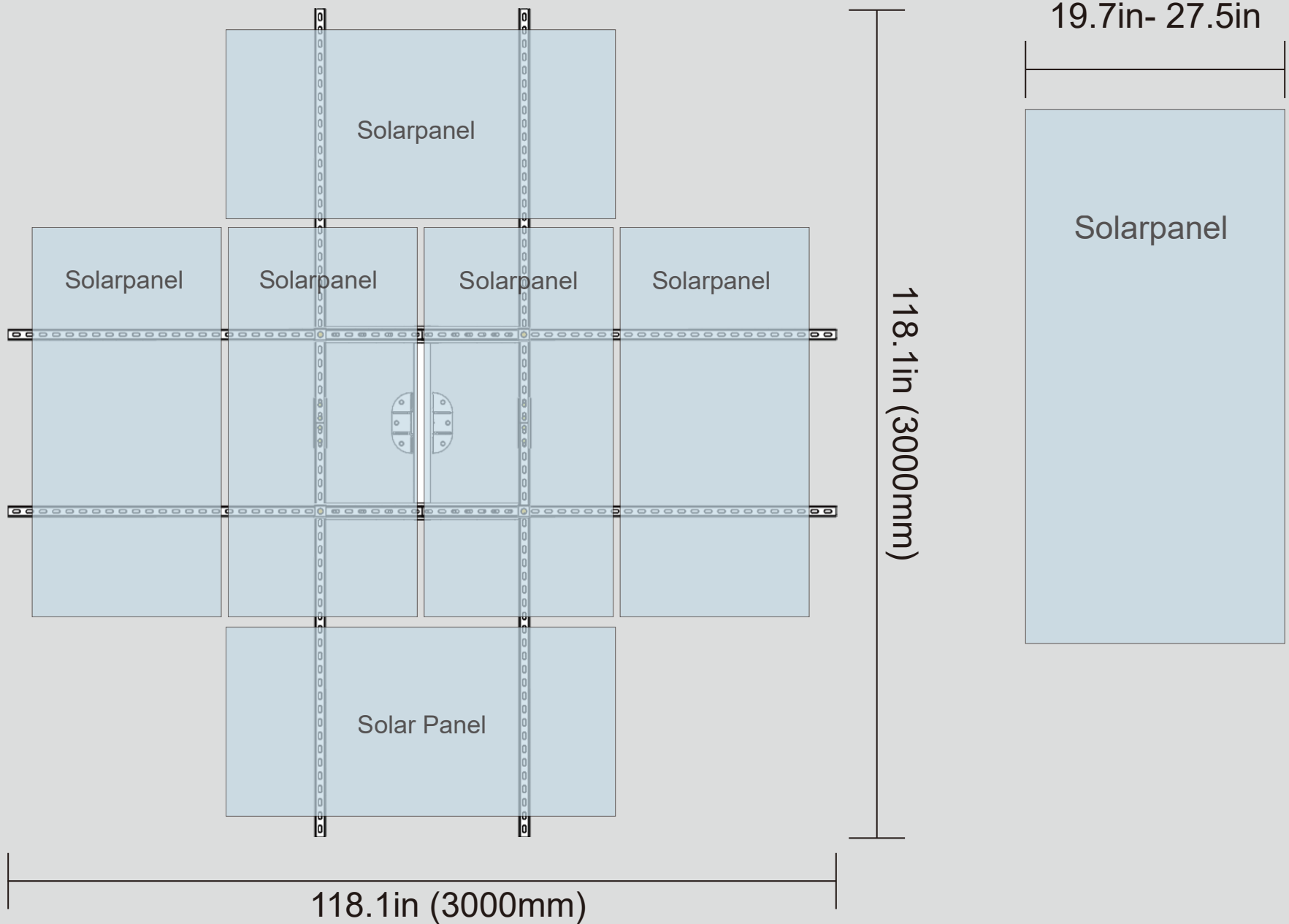

UNTERSTÜTZUNG

- Für die Verwendung dieses Handbuchs und die Bedingungen oder Methoden der Installation, des Betriebs, der Verwendung und der Wartung des Produkts außerhalb der Kontrolle von ECO-WORTHY liegen, übernimmt ECO-WORTHY keine Verantwortung und lehnt ausdrücklich die Haftung für Verluste, Schäden oder Kosten ab, die aus oder in irgendeiner Weise mit einer solchen Installation, Betrieb, Verwendung oder Wartung entstehen.
- ECO-WORTHY übernimmt keine Verantwortung für jegliche Verletzung von Patenten oder anderen Rechten Dritter, die sich aus der Verwendung des Produkts ergeben können.
- Keine Lizenz wird stillschweigend oder anderweitig unter Patent- oder Patentrechten erteilt.
- Die Informationen in diesem Handbuch basieren auf dem Wissen und der Erfahrung von ECO-WORTHY und werden als zuverlässig angesehen, aber solche Informationen einschließlich Produktspezifikationen (ohne Einschränkungen) und Vorschläge stellen keine ausdrückliche oder implizite Garantie dar.
- ECO-WORTHY behält sich das Recht vor, das Handbuch, die Produkte, die Spezifikationen oder Produktinformationsblätter ohne vorherige Ankündigung zu ändern.
- Dieses Produkt ist durch eine einjährige Garantie von ECO-WORTHY Ltd. abgedeckt. Wir erstatten oder teilweise Rückerstattung oder ersetzen Produkte mit Mängeln aufgrund unserer Unvorsichtigkeit. Wenn Sie technische Probleme haben und in diesem Handbuch keine Lösung finden können, wenden Sie sich bitte an ECO-WORTHY, um weitere Hilfe zu erhalten.

Kontaktnummer:

US: 1-866-939-8222

UK: +44 20 7570 0328

DE: +49 693-1090-113

E-Mail:

customer.service@eco-worthy.com

Installation-Einstellung Video:



