

LED Lighting Fixture

SAVE THESE INSTRUCTIONS



BEFORE YOU BEGIN

Read and follow all safety instructions



WARNING

RISK OF FIRE, EXPLOSION AND ELECTRIC SHOCK

- This product should be installed, inspected, and maintained by a qualified electrician only, in accordance with the NEC (National Electric Code) and all local codes.
- Turn off electrical power before inspection, installation or removal.
- Use only UL (or other NRTL) approved wire for input/output connections. Minimum size 18 AWG or 14 AWG for continuous runs.
- Make sure LEDs and drivers are cool to touch when performing maintenance. Make sure the supply voltage is the same as the rated voltage of the luminaire.
- Do not install in a hazardous atmosphere, except where the ambient temperature does not exceed the rated operating temperature of the fixture.
- Keep tightly closed when in operation



Prepare Electrical Wiring



Electrical Requirements

- The LED driver must be supplied with the Voltage Specified in the parameter label and connected to an individual, properly grounded branch circuit protected by a 20 Ampere circuit breaker. Use min. 75°C supply.



Grounding Instructions

- The grounding and bonding of the overall system shall be done in accordance with NEC Article 600 and local codes

LED Flood Light

Installation Guide

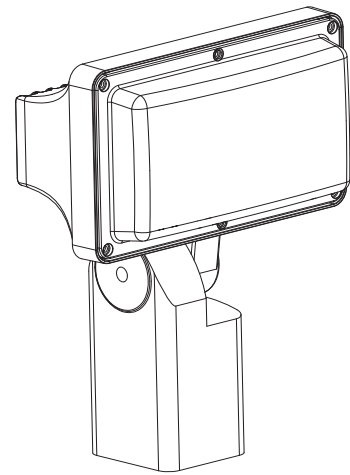
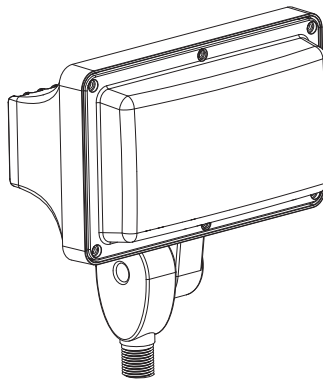
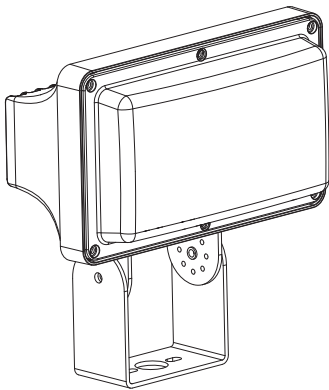

Tools Required:
Crescent Wrench
Wire Strippers
Wire Cutters

Phillips Screwdriver

- Before starting make sure that the power is disconnected.
- Unpack fixture and ensure that there are no damaged parts.
If using Trunion:
- Secure fixture to flat mounting surface using 2 bolts.
- Remove the small phillips head locking screw on the trunion.
- Aim fixture by loosening the 2 bolts on the bracket to the desired angle. Tighten both bolts once in the desired position.
- Reinsert the small phillips head locking screw on the trunion.
- Insert power cord into junction box. Ensure there is a water tight seal going into the junction box.
- Wire end of cord to power supply as seen below.
If using Knuckle Mount:
- Attach fixture to outdoor box cover, routing the fixture wires into the junction box. Connect fixture cables as seen below. Black to Black, White to White, Green to Green.
- Seal threading using Teflon tape or a silicone sealant for watertight application.
- Aim fixture by loosening the screw on the arm, and reposition to the desired angle. Tighten the screw.
If using Slip Fitter:
- For slip fitter installation pass the wires from the slip fitter into the tenon post top.
- Make connections as seen below. Black to Black, White to White, and Green to Green.
- The fixture can be aimed using the tilting motion of the slip fitter and the rotating motion of the slip fitter on the tenon.
- The slip fitter can be tilted by loosening the securing screw and tilting the fixture up or down.
- Once the desired angle is achieved tighten back the securing screw.
- The slip fitter is secured to the tenon by tightening the 2 grub screws on the side.

To adjust the CCT: Remove the fixture lens to expose the selector switch. Change to the desired setting and replace lens, making sure the gasket is seated properly and the lens screws are tightened to 7.5□□.5 lbf□n to avoid water ingress.

Standard Wiring Diagram

