

## UFO LED HIGH BAY LIGHT



### PRODUCT FEATURES:

- ❖ LUMILEDS LED, high luminous efficiency and long working life.
- ❖ High efficiency LED Driver, the wide range input voltage AC120-277V ;
- ❖ Magnesium alloy design, better cooling, light quality, LED Tj < 85°C.
- ❖ Optical design, greatly improved the light utilization and evenness

MODEL #	
PROJECT:	
NOTES:	
DATE:	
PREPARED BY:	

### Additional Information:

- Power: 200W
- Input: AC 120-277V
- CCT : 5000K
- Output: 27200 LM
- Light Source: LUMILEDS
- Driver: SOSEN POWER

### Structure Features:

- Shell Material: Magnesium Alloy
- Color: Black
- Weight: 13 lbs.



### PRODUCT APPLICATIONS:

The 1000LED UFO High Bay LED Lighting Series can be widely used in Warehouses, Industrial Areas, Gymnasiums, Stadiums, Exhibition Halls, Workshops, Manufacturing Facilities, Distribution Centers, Storage Areas, Grocery Stores, High Bay Garages and Big Box Retailers

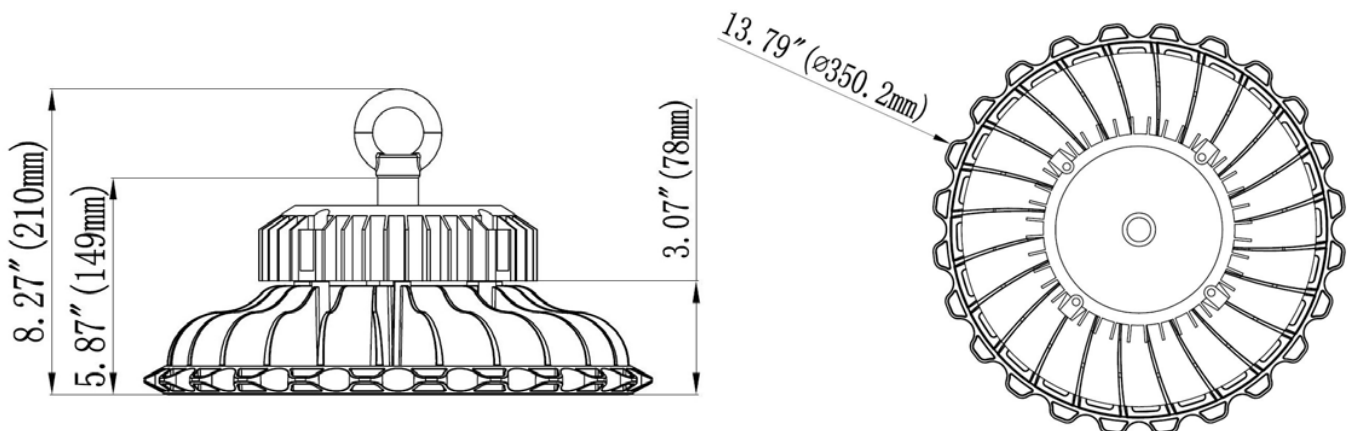

## UFO LED HIGH BAY LIGHT

### TECHNICAL PARAMETERS:

Type	1L-UHB20W27-XXK-AL-M		
Power	200W	Lighting Angle	80°
Input Voltage	AC120-277V	LED Brightness Decay	<5%/6000 hrs
PF	>0.95	Working Life	>100000 hrs
Driver Efficiency	>90%	Working Temperature	-30 - +45°C
Luminous Flux	27200 Lm	Storage Temperature	-40 -+80°C
Color Temperature	3000K/4000K/5000K/5700K	Protection Level	Wet Location/IP65
CRI	Ra>80	Cable	3 core, 18AWG (0.5m)

### IRRADIATION AREA: (80 degree lens)

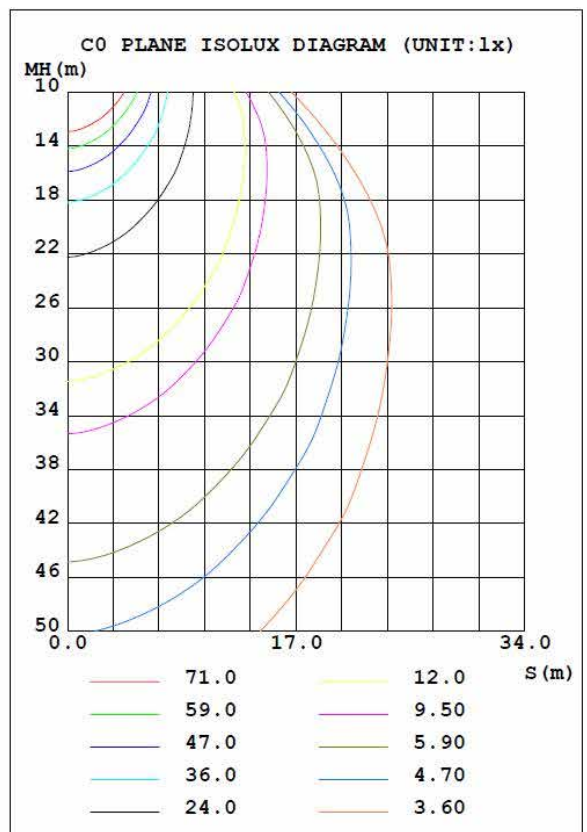
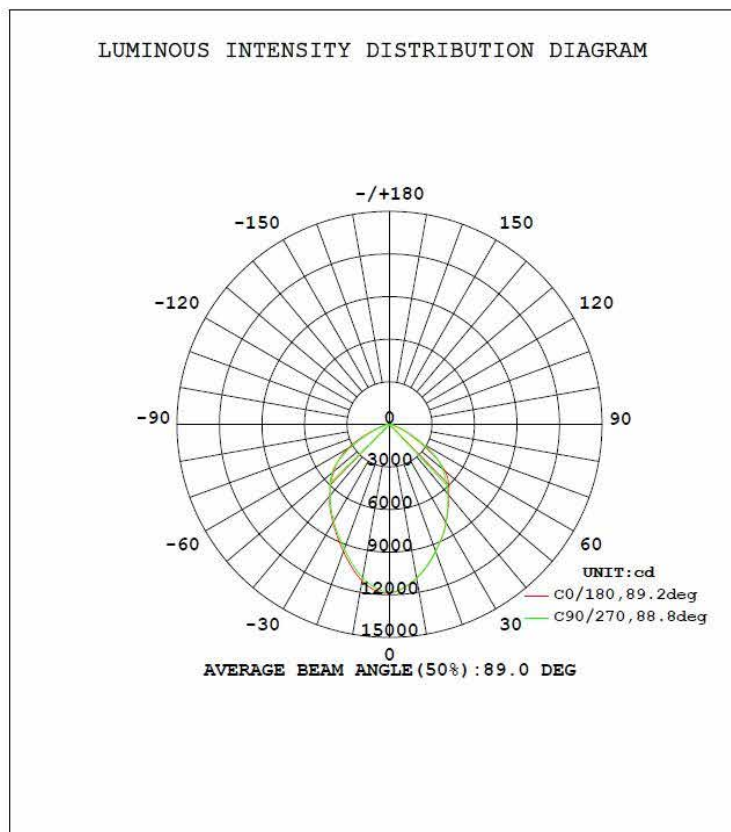

## UFO LED HIGH BAY LIGHT

### ORDERING INFORMATION:

**EXAMPLE: 1L-UHB 20W 27-50K-AL-M**

1L	CP	20W	27	50K	AL	M
Company	Product	Power	Voltage	ColorTemp	Parts	Control
<b>1000LED</b>	<b>UHB</b> UFO High Bay Light	<b>10W</b> (100W) <b>15W</b> (150W) <b>20W</b> (200W)	<b>27</b> AC120-277V	<b>30K</b> (3000K) <b>40K</b> (4000K) <b>50K</b> (5000K) <b>57K</b> (5700K) <b>± 500K</b>	<b>AL</b> Aluminium lampshade	<b>10V</b> Dimming 1-10V <b>M</b> Motion Sensor

### PRODUCT CERTIFICATIONS:

