

HOURGLASS POST TOP LIGHT



PRODUCT FEATURES:

- ❖ SMD 2835 LEDs, high luminous efficiency and long working life.
- ❖ High efficiency LED Driver, wide range input voltage AC120-277V;
- ❖ Die-cast alloy design, better cooling, light quality, LED Tj < 85°C.
- ❖ Optical design, greatly improved the light utilization and evenness
- ❖ Excellent Efficiency 140Lm/w

MODEL #	
PROJECT:	
NOTES:	
DATE:	
PREPARED BY:	

Additional Information:

- Power: 100W
- Input: AC 120-277V
- CCT : 5000K
- Output: 13971 LM
- Light Source: SMD 2835 LEDs
- Driver: WELED POWER



PRODUCT APPLICATIONS:

1000LED Post Top Lighting Series can be widely used in Parks, Pathways, Courtyards and more

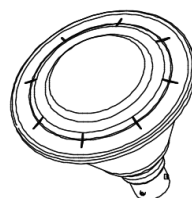
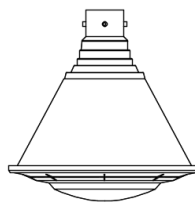
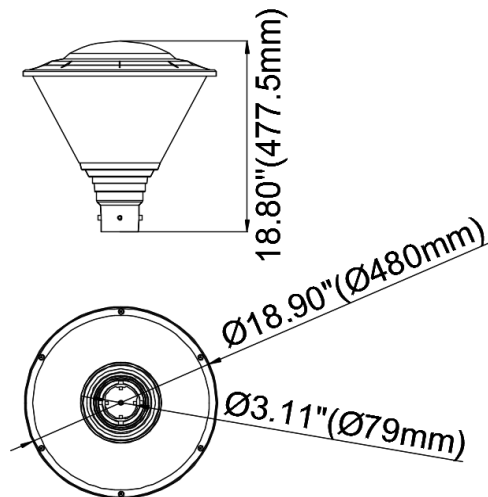

STRUCTURE FEATURES:

- Shell Materials: Aluminum & PC
- Finish: Dark Bronze/White/black(Option)
- Net Weight: 7.7KG (17LBS)
- **Product Size: 480mm*477.5mm**
- **Carton Size: 505mm*505mm*535mm**

TECHNICAL PARAMETERS:

Type	1L-HPT06W27-XXK-Z-E		
Power	100W	Lighting Angle	162°
Input Voltage	AC120-277V	LED Brightness Decay	<5%/6000 hrs
PF	>0.98	Working Life	>75000 hrs
Driver Efficiency	>90%	Working Temperature	-30 - +45°C
Luminous Flux	13971 Lm	Storage Temperature	-40 -+80°C
Color Temperature	4000K/5000K	Protection Level	Wet Location
CRI	Ra>70	Cable	3 CORE/18AWG

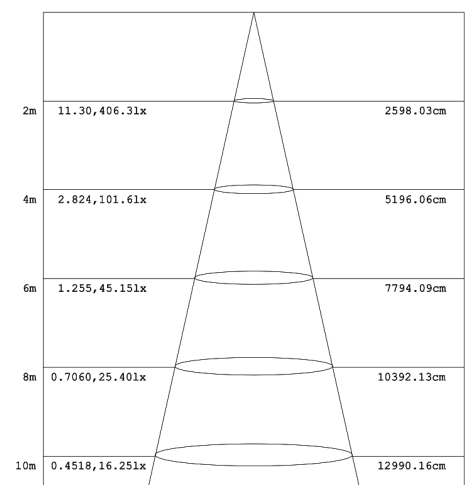
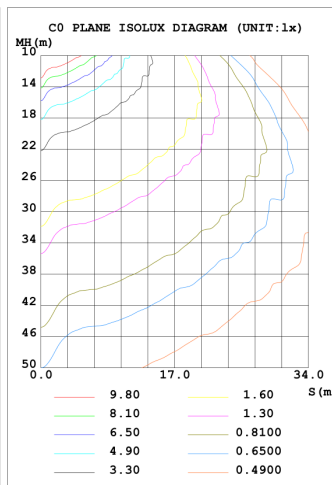
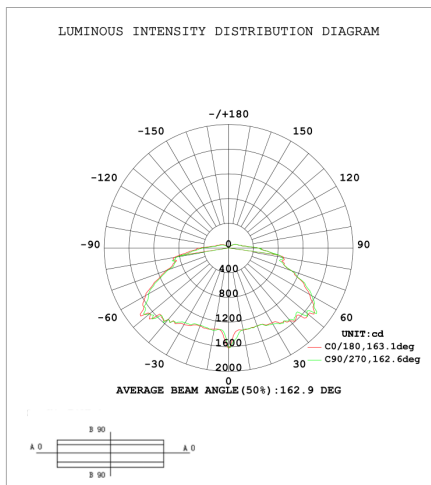

ORDERING EXAMPLE: 1L-HPT10W27-XXK-Z [D, W, B, S] -E [blank, M]

1L	HPT	10W	27	XXK	Z	E
Company	Product	Power	Voltage	ColorTemp	FINISH	Control
1000LED	HPT Hourglass Post Top Light	06W (60W) 10W (100W)	AC120-277V	40K (4000K) 50K (5000K) ± 500K	D (Dark Bronze) W (White) B (Black) S (Silvery)	M Motion Sensor