

ASSEMBLY INSTRUCTION

ITEM#: 210H4522-15

ITEM#: 210H4522WH-15

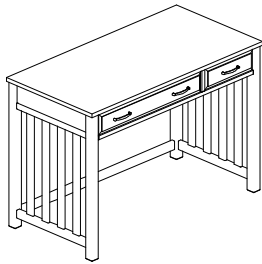

IMPORTANT NOTE:

- Place all wooden parts on a clean and smooth surface such as a rug or carpet to avoid the parts from being scratched.
- Check to be sure that you have all parts and hardware.
- Remove all wrapping materials, including staples & packing straps before you start to assemble.
- Do not tighten all screws / bolts until all completely assembled.
- Keep all hardware parts out of reach of children.

PART LIST LISTE DE PIÈCES

NO	DESCRIPTION	QTY/PCS
1	TOP	1 PC
2	SIDE PANEL FRAME (L/R)	2 PCS
3	CROSS BAR	1 PC

HARDWARE LIST LISTE DE QUINCAILLERIE

NO	DESCRIPTION	QTY/PCS
A	JCBC BOLT / BOULON M6 x 1.0 x 45mm	8 PCS
B	SPRING WASHER / RONDELLE D' ARRET 1/4" x 9/32" x 15/32" x 0.04"	8 PCS
C	FLAT WASHER / RONDELLE PLATE 1/4" x 9/32" x 3/4" x 0.04"	8 PCS
D	ALLEN KEY / CLÉ ALLEN M4 x 60mm	1 PC
E	CSK SCREW / VIS M4 x 45	2 PCS

Step 1
Remove drawer from Top.

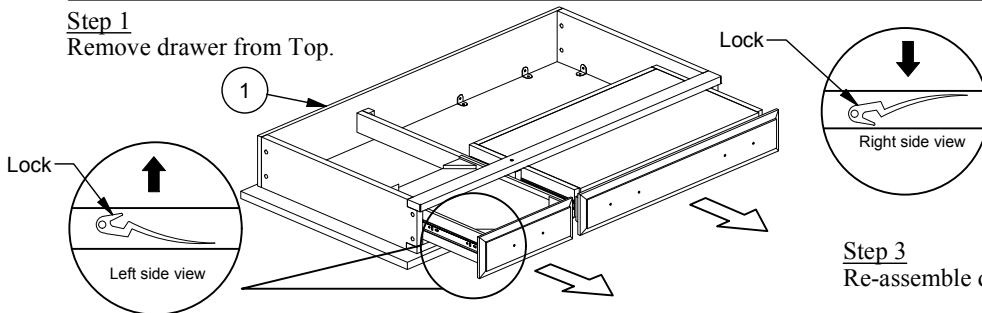

Step 2

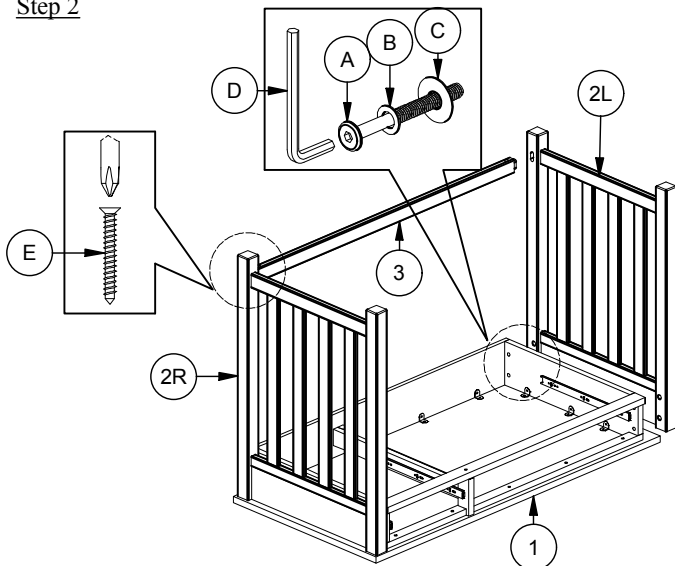

Step 3
Re-assemble drawer to Desk.

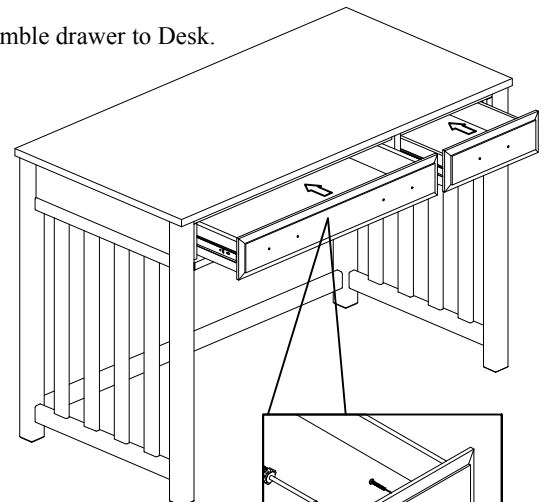

Re-assemble handle from inside to outside position.

ASSEMBLY INSTRUCTION

ITEM#: 210H4522-15

ITEM#: 210H4522WH-15

ASSEMBLY INSTRUCTIONS FOR DRAWER REMOVAL AND REINSTALL FOR CASEGOODS

TO REMOVE DRAWER:

STEP 1 : EXTEND THE BOX DRAWER TO ITS FULL EXTENSION.

STEP 2 : LOCATE THE DRAWER SLIDE LOCK ON EACH SIDE OF THE DRAWER BOX.

PULL UP THE LOCK ON THE LEFT SIDE OF THE DRAWER BOX AND PUSH DOWN THE LOCK ON THE RIGHT SIDE OF THE DRAWER BOX IN THE SAME TIME AND PULL DRAWER STRAIGHT OUT UNTIL SLIDE DRAWER MEMBERS DISENGAGE FROM CABINET MEMBERS.

STEP 3 : REMOVE THE DRAWER.

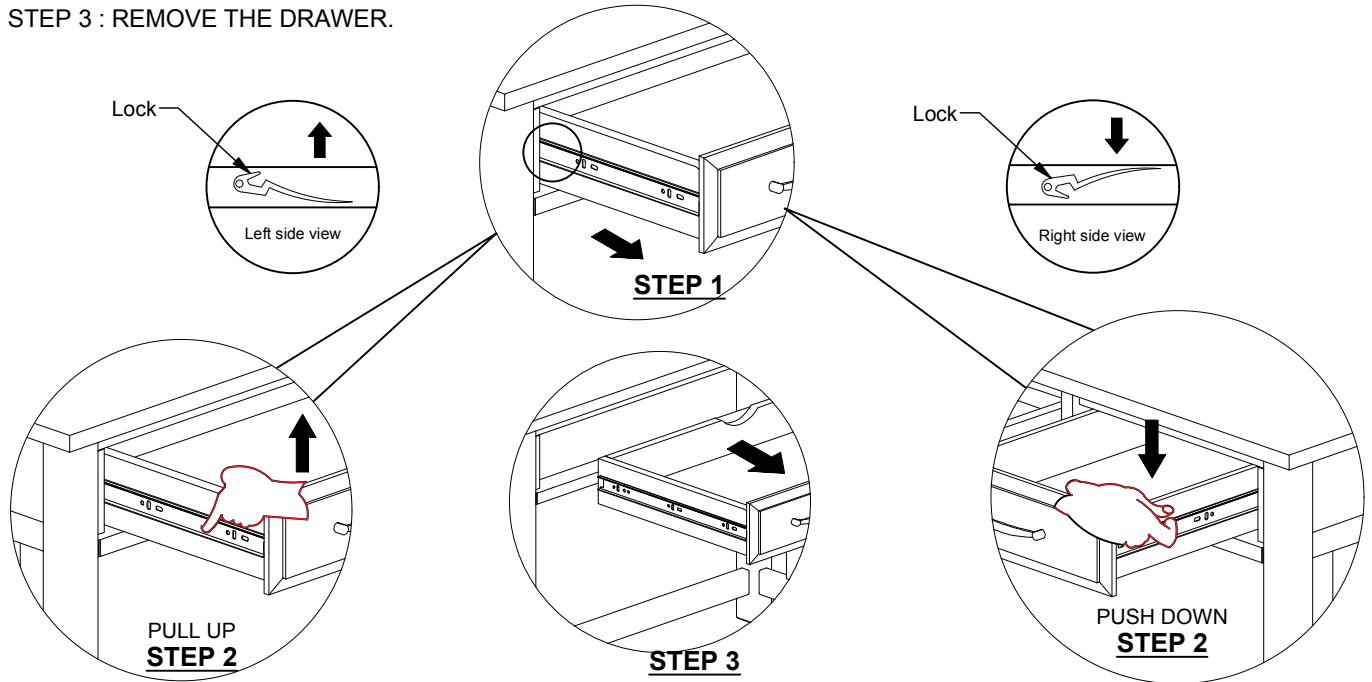

TO REINSTALL DRAWER :

MAKE SURE THE DRAWER WILL BE RE-INSTALL TO ITS ORIGINAL POSITION.

STEP 1 : INSERT DRAWER BY PULLING TRACK ON THE LEFT AND RIGHT CABINET MEMBERS ALL THE WAY FORWARD (INCLUDING BALL BEARING RACK)

STEP 2 : ALIGN TRACKS ON DRAWER WITH SLIDERS AND PUSH IN THE DRAWER UNTIL THERE IS AUDIBLE "CLICK" SOUND.

STEP 3 : CHECK FOR PROPER ALIGNMENT BY INSPECTING DRAWER FRONT MARGINS FOR SPACING AND SQUARENESS.

OPEN AND CLOSE SLOWLY SEVERAL TIMES TO ENSURE THE PROPER INSTALLMENT.

IF THERE IS ANY UNEVEN, PLEASE REPEAT STEP OF REMOVAL AND REINSTALL THE DRAWER.

