

# ASSEMBLY INSTRUCTION





ITEM#:210D1133-24S





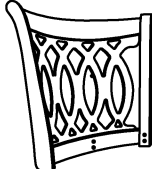
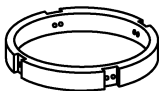



ITEM#:210D1133-29S

## IMPORTANT NOTE :

- To prevent scratch, place all wooden parts on a clean and smooth surface such as carpet.
- Keep all hardware parts out of reach of children
- Follow assembly instruction step by step



PARTS LIST	
(A) 	(C)  Footrest -1 Pc
Backrest -1 Pc	(D)  Apron with swivel plate -1 Pc
(B) 	(E)  Chair Leg ----4 Pcs
Cushion Seat -1 Pc	

HARDWARE LIST			
No	Description		QTY
1	JCBC Screw M6 x 25mm		4 Pcs
2	JCBC Screw M6 x 40mm		12 Pcs
3	JCBC Screw M6 x 45mm		6 Pcs
4	Spring Washer M6 x 13mm		18 Pcs
5	Flat Washer M6 x 13mm		12 Pcs
6	Flat Washer 6.5 x 16.5mm		6 Pcs
7	Flat Washer 1/4" x 19mm		4 Pcs
8	Wood Dowel M10 x 35mm		4 Pcs
9	Allen Key M4 ( Long )		1 Pc

**NOTE :** Do not tighten all screws until the stool is fully set-up.

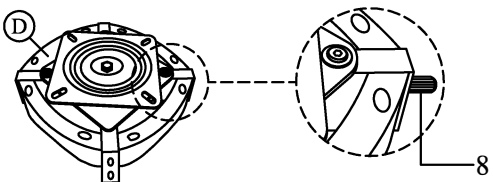
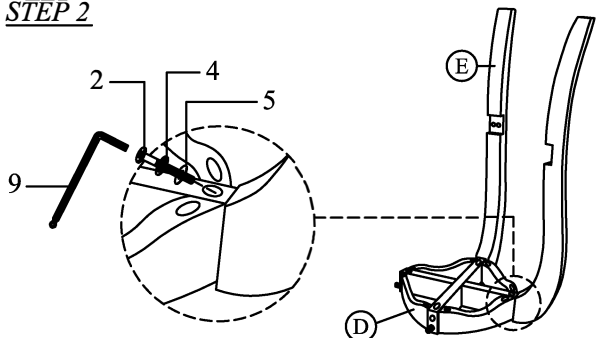
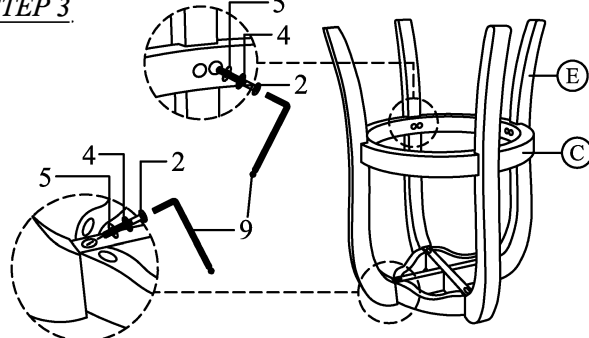
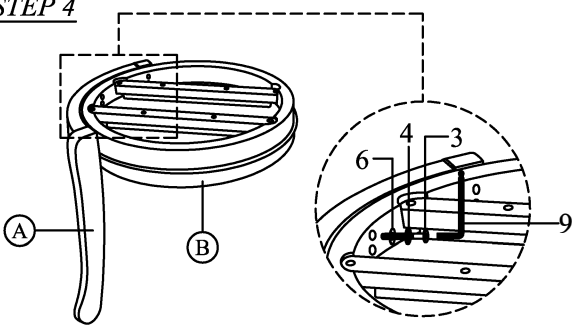
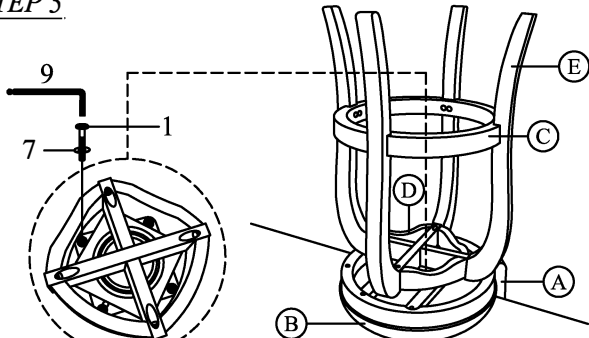
<p><u>STEP 1</u></p> 	<p><u>STEP 2</u></p> 
<p><u>STEP 3</u></p> 	<p><u>STEP 4</u></p> 
<p><u>STEP 5</u></p> 	<p><u>STEP 6</u></p> 