



The leaders in heating and cooling

www.bonaire.com.au
Customer Care 1300 665 087

Thank you for purchasing a quality Bonaire Evaporative Portable Cooler.
We care about your safety and would ask you to spend a few minutes
reading these simple instructions before operating this product.

Instruction Manual

Crown 10i

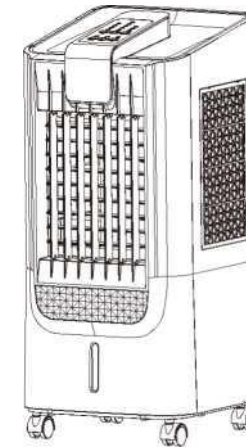

BONAIRE CROWN 10i

IMPORTANT

READ AND SAVE THESE INSTRUCTIONS.

Please keep this important manual in a safe place.
It is the owner's responsibility to ensure that regular maintenance is
carried out on this evaporative cooling product.



The leaders in heating and cooling

WARNING

1. Unplug and disconnect the cooler from power source before attempting any maintenance, service or cleaning and filling water.
2. If the supply cord is damaged, it must be replaced by authorized service provide to avoid hazard. Do not operate the product with a damage power cord or plug.
3. This appliance is not intended for use by person (including children) with reduced physical, sensory, or mental capabilities, or lack of experience and knowledge, unless they have been given supervision or instruction concerning use of the appliance by a person responsible for their safety.
4. Children of less than 3 years should be kept away unless continuously supervised.
5. Children aged 3 years and above shall only switch on/off the appliance if it has been placed or installed in its intended normal operating position and they have given supervision or instruction concerning use of the appliance in a safe way and understand the hazards involved. Children aged 3 years and above shall not plug in, regulate, and clean the appliance or perform user maintenance.
6. Children must not be allowed to play with the cooler.
7. This appliance is not intended to be used in locations where special conditions prevail, such as the presence of a corrosive or explosive atmosphere (Vapor or gas).
8. This appliance can be used by children aged from 8 years and above and the persons with reduced physical, sensory, or mental capabilities or lack of experience and knowledge if they have been supervision or instruction concerning use of the appliance in a safe way and understand the hazard involved. Children shall not play with the appliance. Cleaning and user maintenance shall not be made by children without supervision.



This marking indicates that this product should not be disposed off with the other household wastes throughout the EU and other applicable countries. To prevent possible harm to the environment or human health from uncontrolled waste disposal, recycle it responsibly. If you wish to discard this product, please contact your local authorities or dealer from where it was purchased and ask for correct method of disposal.



Cooling performance depends on temperature of water used, relative humidity and ambient temperature.

- An unauthorised person has attempted to repair the appliance;
- A situation arises which is referenced in the trouble-shooting guide (because you as the purchaser are required to remedy such a situation yourself).

Please note that a charge will be made for work done or a service call made where the Climate Technologies authorised representative or agent determines at his/her sole discretion (acting reasonably) that there is nothing wrong with the product in question.

How to exercise your rights under this warranty

Only qualified service personnel should conduct any service work carried out on the Climate Technologies product. If you acquire a product or service from Climate Technologies which is defective, please contact Climate Technologies on the phone numbers or emails listed below. Please note you will be required to show proof and provide us with the products serial number and comply with the terms and conditions and all other applicable provisions of this warranty for Climate Technologies to proceed with the remedial action prescribed under this warranty.

Service Hotline: 1300 665 087

e-mail us: service@climtech.com.au

Book a request online at: www.bonaire.com.au/support

Warranty on Replacement Parts

Parts replaced under warranty are warranted for the balance of the original warranty period.

WARRANTY REGISTRATION

Product must be registered within 21 days from the date of purchase. A copy of your proof of purchase must be submitted together with your registration. Please choose one the three option below to register your product for warranty as follows:

1. Scan the QR code below using your mobile device and follow to fill out the online warranty registration form.



2. Visit the website at: www.bonaire.com.au/service and complete our online warranty registration form.
3. Fill out the details below and post this page together with a copy of your proof of purchase to:

Climate Technologies
Warranty Registration Service
26 Nylex Avenue
Salisbury South
SA 5106

Date of Purchase: _____

Model : _____

Serial No: _____

Full Name: _____

Address 1: _____

Address 1: _____

Suburb: _____

State: _____ Post Code: _____

e-mail: _____

Telephone No: _____

Mobile No: _____

- Travelling time and mileage are included in the service within 30km of either your authorised Climate Technologies dealer or service provider's premises. Customers in areas other than the above are responsible for any travelling time and mileage required to carry out warranty repairs.

Warranty Period

Model – Crown 10i
12 months warranty

Remote Location Warranty

If the product is located outside of the Climate Technologies service network, a supply part only warranty will apply. Only parts will be supplied free of charge where the product the subject of the warranty claim was located further than 30km from the nearest Climate Technologies authorised dealer or service providers premises, and then only on the return of the faulty part. In the event that a warranty claim is made to which this provision applies, you will be responsible for all labour charges incurred for the part to be fitted by a qualified person, such a person to be appointed by Climate Technologies or one of their authorised dealers. The labour warranty prescribed in the table above of this warranty are void where the product in question has been installed in an area outside the Climate Technologies network (as prescribed above).

Effect of this Warranty

If you, as the purchaser of a product sold by Climate Technologies, comply with your obligations under this warranty document and a defect exists in a product you have purchased from Climate Technologies, Climate Technologies will, at its sole discretion, repair or replace the defective product (or part of it). Any remedial work undertaken by Climate Technologies or one of its approved representatives or agents will be conducted at Climate Technologies sole expense, subject to the terms and conditions and exclusions contained in this warranty. Climate Technologies will not reimburse you for any expense you have incurred in applying for a remedy under this warranty, including, but not limited to, any telephone calls or postage expenses incurred.

Exclusions to Warranty

The following are not covered under this warranty, and Climate Technologies takes no responsibility for the replacement or repair of:

- Consumable items which are subject to wear and tear such as filter pads, drive belts, batteries and bearings;
- Any third-party components used as part of the installation such as grilles, filters, fittings, pipe work, etc. These items are warranted from your place of purchase;
- Damage caused by elements such as wind, rain, lighting, floods etc along with power spiking and brownouts which are not considered by Climate Technologies in their sole discretion (acting reasonably) to be defective material or workmanship;
- Damage caused by outside elements such as pests, animals, pets and vermin or similar that may cause damage to the product;
- Harsh environmental situations such as salt air that may cause cabinet damage and/or rusting.
- Products used for commercial rental purposes or hire

Please be aware that to the extent permitted by law, the manufacturer does not accept liability or any claims for damage to building contents, carpet, walls, ceilings, foundations or any other consequential loss incurred by you or any other person as a result of the purchase or installation of a product from Climate Technologies or by any other means, whether such loss was incurred directly or indirectly. For the avoidance of doubt, damage resulting from power spikes, incorrect operation, incorrect installation, and incorrect maintenance is also not covered under this warranty and such damage is not the responsibility of Climate Technologies.

All warranties contained in this warranty are given for the exclusive benefit of you as the purchaser of a Climate Technologies product and are not transferable and cannot be sold, assigned, gifted or transferred in any other way.

Events where warranty may be void

In the event that any of the following occur, this warranty may be void, and Climate Technologies reserves the right to refuse to repair or replace a defective product in accordance with a term of this warranty, where:

- The product operates defectively due to failure of electricity or water supply,
- The defect is caused by neglect, incorrect application, abuse or by accidental damage to the product;

SAFETY GUIDELINES

Thank you for your choosing the Bonaire evaporative portable air cooler. To have an in-depth understanding our product and to ensure its proper use, please read this instruction manual carefully, especially notice the relevant information marked with Warning and Caution before using it.

CROWN 10i PRODUCT CONSTRUCTION

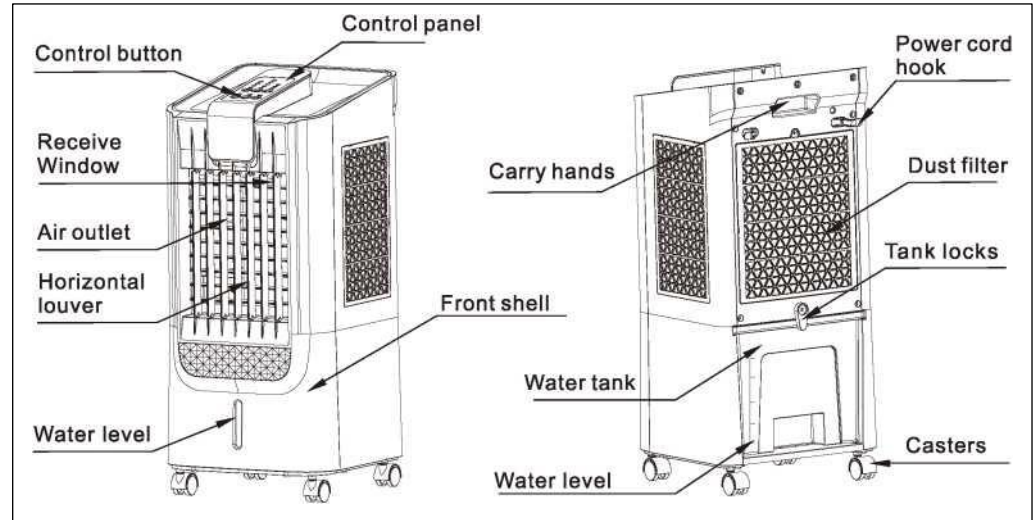

WHEEL INSTALLATION

When you open the carton box and before using the evaporative cooler, please install the wheels as following instruction: First, insert the two wheels without brake into the hole in the front of chassis, and then insert the two wheels with brake into the hole in the rear of chassis. (See below picture)

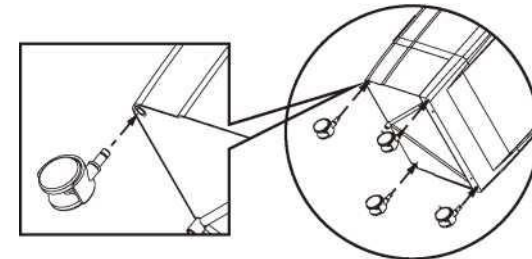

CONTROL PANEL

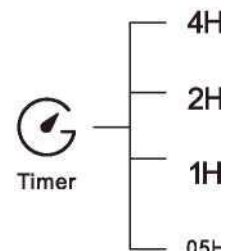
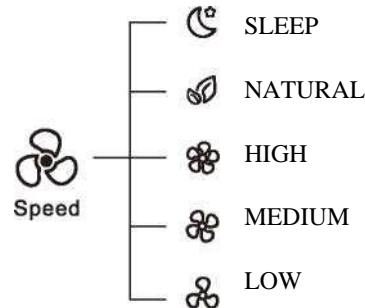
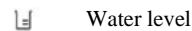

WARRANTY INFORMATION

Product Sr. No.

The warranties contained in this document ("the warranty") are provided voluntarily by Climate Technologies (as manufacturer) to you (as consumer) in relation to your purchase of a product from Climate Technologies ("the product") and are in addition to any rights you may have under the Australian Consumer Law or other applicable legislation. Please read this warranty in full and complete the Dealer / Product information above. KEEP this with your original purchase receipt for any claim you may wish to make under this warranty.

Australian Consumer Law

The Product comes with consumer guarantees that cannot be excluded under the Australian Consumer Law.

If we breach these consumer guarantees, you are entitled (at your choice) to a replacement or refund in respect of a "major failure" (as that term is defined in section 260 of the Australian Consumer Law) of the Product. You are also entitled to have the Product repaired or replaced (at our choice) if the Product fails to be of acceptable quality and the failure does not amount to a "major failure".

The manufacturer's warranty contained in this booklet is in addition to any rights and remedies that you may have and may wish to rely on under the Australian Consumer Law or any other law in relation to the Product. No other person, company, entity or corporation is authorised to offer or give on our behalf, any other warranty.

Warranty Procedures

Firstly, refer to this owner's manual to ensure that you have followed the correct operating procedures of your product, and refer to the trouble shooting guide to assist solving any problems you may have.

1. Read this warranty statement carefully before you request warranty service as items related to installation are not covered by this appliance warranty.
2. Proof of product purchase must be provided by you to Climate Technologies when exercising any rights under this or any statutory or other warranty, as evidence that the appliance is within the relevant manufacturer's warranty periods.
3. This warranty is only for Climate Technologies products and associated original controls for Climate Technologies manufactured product.
4. Only an authorised Climate Technologies service provider may carry out a warranty service.
5. To the extent permitted by law, any statutory warranty that applies to goods sold by Climate Technologies is valid for 12 months from the date of purchase and any additional warranties provided to you are at the sole discretion of Climate Technologies.

Climate Technologies provides the following Manufacturer's warranty on new products from the date of original purchase in addition to all implied warranties and other statutory rights which you may have under the Australian Consumer Law and similar State & Territory Laws, subject to the following terms and conditions.

Terms and Conditions

This warranty is subject to, and conditional upon, the following terms and conditions:

- Subject to the exclusions noted, Climate Technologies warrant the product for the period as prescribed in the table below to be free from inherent defects in materials and workmanship for functional and structural components.
- This warranty is only valid if the product is operated and maintained in accordance with the manufacturer's instructions
- The appliance must not be modified or changed in any way.
- Your proof of purchase MUST be produced before free service will be provided together with a valid serial number.
- The product must be registered within 30 days of purchase by following the instructions listed in the following page.

6. If pack for storage or transportation, please drain the water and make the unit working a few minutes, after totally dry then pack it, to avoid the peculiar smell.
7. Don't keep the plug connecting when long time no using the unit, it will be damaged.
8. If the supply cord is damaged, it must be replaced by the manufacture or its service agent or a similarly qualified person to avoid a hazard.
9. The unit has strong humidity effect, please shut this function in the airtight environment.
10. Filling water when it is in the low water level.
11. This appliance is not intended for use by persons (including children) with reduced physical, sensory or mental capabilities or lack of experience and knowledge, unless they have been given supervision or instruction concerning use of the appliance by a person responsible for their safety.
12. Children should be supervised to ensure that they do not play with the appliance.

TECHNICAL PARAMETER

Model	Air Flow Rate	Voltage	Input Power	Sound Pressure Level	Water Tank Capacity	Evaporation Capacity	N. W.	Dimension(mm) L x W x H
Crown 10i	600m ³ /h	AC220-240V,50Hz	65W	50dB(A)	10L	1.6L/h	4.9kg	285 X 298 X 638mm

ELECTRICAL SCHEMATIC

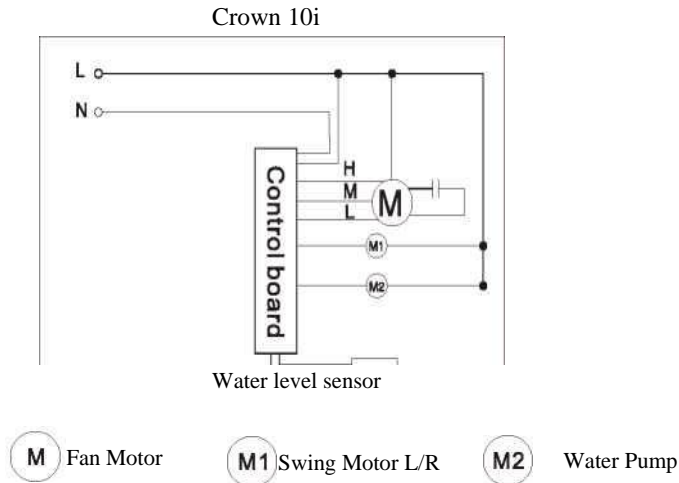

BONAIRE Evaporative Cooler
"For Indoor Use Only"

Model : Crown 10i
Voltage : 220-240V
Frequency : 50Hz
Input Power : 65W

warning : the power must be shut off before maintenance.
"Refer to instruction Manual"

Made in China

FUNCTIONS OF ALL BUTTONS

ON/OFF  Switch on this button to open the air cooler, with a short sound "BI". Meanwhile, functions for cooling and swing are turned on automatically. High speed wind is starting. To close the aircooler, switch off the "ON/OFF" button.

COOL  This cool function is started automatically after opening the air cooler when the unit have enough water. Push the button to change into humidification. To press it once more will open cool function again.

SWING L/R  This function is started immediately after opening the air cooler, shown by the lighted SWING L/R indicator. Under this condition, the wind board slowly sways from left to right. To stop this function as well as the indicator, just push this button. Pushing it once more will start the swaying of wind board once again.

SPEED Press this button to change the speed of wind after starting the air cooler. Wind speed can be changed from high, natural, sleep, low to medium. Indicator for each wind speed works in need more than 2 second after changing the speed.



TIMER  The timer function turns on when press this button on standby mode and can set timer power on from 1 hour to 7.5 hours by hour. After turning on the machine, press this button to set timer power off function from 1 hour to 7.5 hours by hour. Release this function can press this button to change the time and can press "ON/OFF" button directly.

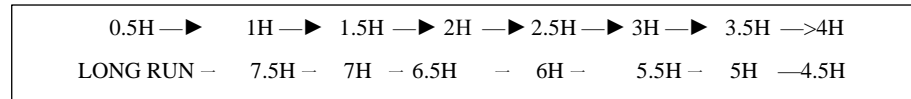

WATER LEVEL  The Led light is white when the tank has water, the Led light is red, and machine also make voice alarm when there is no water in the Tank. Once the tank is filled with water then press the cooling button.

OPERATION GUIDE

1. Open the package and take the machine out. Check the content with Instruction Manual.
2. The unit should be placed on a level surface and must always stand in a vertical position.
Check the power supply of the correct rating.
(Refer to the nameplate located at the backside of the unit)

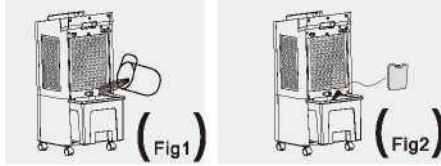

3. Filling water: When the machine is new or unused for a long period, it is necessary to fill in clean water before using. Be sure to unplug the unit before filling water for preventing electrical parts from damage. Open the water tank lock and pull out the water tank, then fill the water into water tank. Notice that the water does not exceed the maximum set level.
4. Ice box: If the cooler has ice box (optional), Before use, put the ice box in the refrigerator for about four hours and then put it into the water inside the machine tank. When putting into the ice box, the water tank should be taken out from the back, and the ice box should be placed horizontally on the side in case the water tank cannot be pulled normally. Fig 2)
Note: Do not open the ice box cover when using, and do not eat ice crystals inside.
5. Adjustable Up and Down winds swing: Open air shutter before the unit turn on. Adjust the louvers up and down manually to comfortable direction.
6. Timing: lightly press the timing switch and the indicator light will be on for 0.5 hours. Press this key once each time, the timing will be increased by 0.5 hours, and any combination of time within 7.5 hours can be obtained. Continue to press this key, when the timing indicator lights are all off, indicating that the machine is in continuous operation. (For Crown I only)
7. Use of the remote control: The buttons on the remote control have the same function as those on the control panel. When in use, the infrared transmitting tube should be pointed at the receive window, and there should be no obstacles between the remote control and the body. (For Crown I only)
8. Storage: In case the unit will not for a long time, the water tank should be drained out and keep the unit running with fan only for a period. Especially the strainer should be entirely dry. Pack it with plastic bag and put it in box.

CAUTION

1. Use normal power supply.

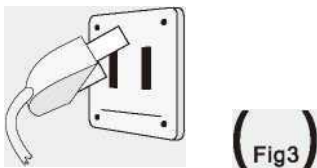

2. After filling with water, do not tilt or collide the unit, when you need to move the unit, push the side surface slowly to avoid water spilling out. Do not overturn the unit in service to prevent accident.

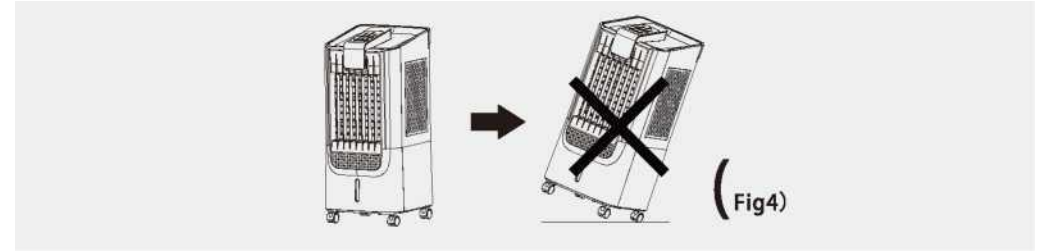

3. Do not place objects on the top of the unit. Do not cover the air outlet when the unit is in use and do not obstruct of front and back of the unit in one meter.

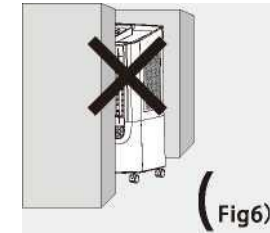
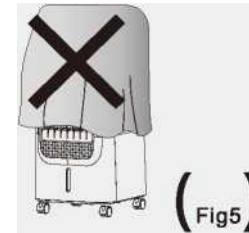

4. The body of the unit may not be place in area with extremely high or low temperature. In hot summer, the water in its water tank is liable to deterioration with odor and should be changed frequently. In winter, at room temperature lower than 0 degree, it is necessary to remove t
5. In cleaning the outer surface of the unit, wet cloth (or with some detergent) should be used. Do not use any corrosive cleaner or solvent for this purpose. Rinsing the unit with water is not allowed.

