

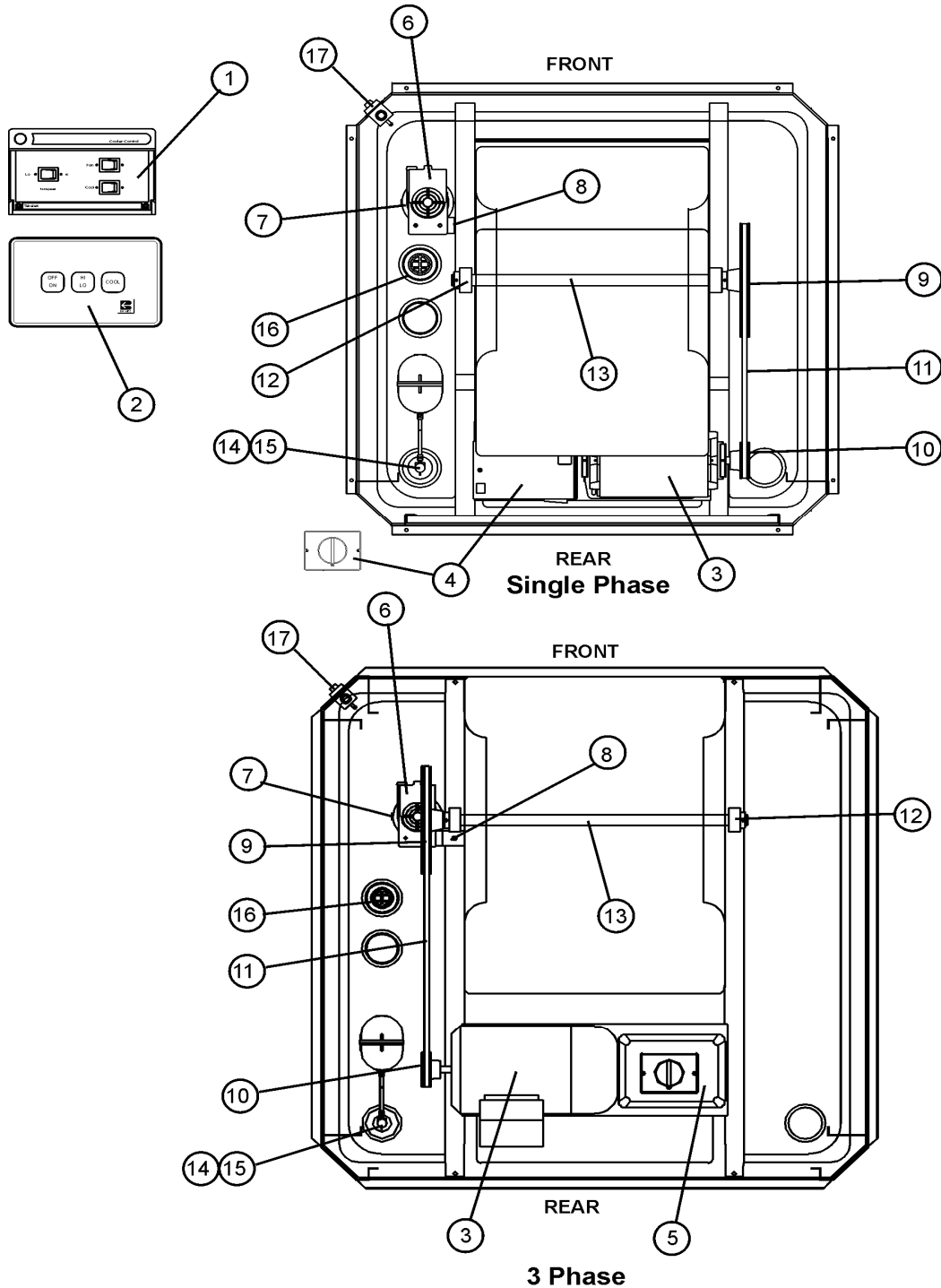

REPLACEMENT PARTS MANUAL

Date Issued 25-Jul-08	Product Section Details Celair Commercial E.A.C. - Ducted Centrifugal	Section No C7.04
Issue Status D	XR Series 8, 10, 12, 14, 15, 15_3	Page 1





REPLACEMENT PARTS MANUAL

Date Issued 25-Jul-08	Product Section Details Celair Commercial E.A.C. - Ducted Centrifugal	Section No C7.04
Issue Status D	XR Series 8, 10, 12, 14, 15, 15_3	Page 2

ITEM NUMBER	DESCRIPTION	PART NUMBER	COMMENTS
1	WALL SWITCH TEK 287	120040SP	XR 8,10,2,15_3
2	WALL SWITCH HPM	1205220SP	XR14, 15
	WALL CONTROL - CELAIR 2 BUTTON	6051620SP	BASIC CONTROL
	WIRING LOOM - LV 20M TEKELEK	6051619SP	TEKELEK
3	MOTOR 2 SPEED .56KW	115050SP	XR8
	MOTOR 2 SPEED .75K	0150514SP	XR10,12
	MOTOR - 0.75 KW 2 SPEED 1PH	115060SP	XR14
	MOTOR 2 SPEED 1.50 KW 1PH	115061SP	XR15
	MOTOR 2 SPEED 1.5KW 3 PHASE	115065SP	XR15_3
	MOTOR .55KW VARIABLE SPEED 1PH	2521601SP	XR8
	MOTOR .75KW VARIABLE SPEED 1PH	2531601SP	XR10,12
	MOTOR - 1.2 KW V/S 1PH	2511603SP	XR14
4	CONNECTION BOX TEK 248	120155SP	XR8,10,23
	CONTROL ISOLATION SWITCH	120581SP	XR15
	CONTROL BOX - TEK600	6051610SP	TEKELEK
5	STARTER 1.5KW DOL HIGH/LOW	120600SP	XR15_3
	FUSE 10AMP	120655SP	XR15_3
6	PUMP ASSEMBLY	6050812SP	
7	STRAINER	6050811SP	
8	BRACKET PUMP	1105030SP	
9	PULLEY FAN 10" 1A AL 25MM	135021SP	XR8,10
	PULLEY FAN 12" 1A AL 25MM	135026SP	XR12,14,15
	PULLEY FAN 12" 1B AL 25MM	135029SP	XR15_3
10	PULLEY MOTOR 3 x 1A x 5/8	0150653SP	XR8,23
	PULLEY MOTOR 3.5" 1A AL5/8BORE	135010SP	XR10,14
	PULLEY MOTOR 4" 1A AL 5/8 BORE	135015SP	XR15
	PULLEY MOTOR 4" 1B AL 28MMBORE	135035SP	XR15_3
11	V BELT A51	135126SP	XR8,10 BOTTOM DISCHARGE
	V BELT A56	135130SP	XR8,10 SIDE DISCHARGE
	V BELT A58	135140SP	XR8,10 TOP DISCHARGE
	V BELT A60	135146SP	XR12,14 BOTTOM DICHARGE
	V BELT A65	135156SP	XR12,14 SIDE DISCHARGE
	V BELT A69	135160SP	XR12 TOP DISCHARGE
	V BELT A70	135165SP	XR14 TOP DISCHARGE
	V BELT A61	135147SP	XR15 BOTTOM DISCHARGE
	V BELT A66	135157SP	XR15 SIDE DISCHARGE
	V BELT A71	135166SP	XR15 TOP DISCHARGE
	V BELT B61	135176SP	XR15_3 BOTTOM DISCHARGE
	V BELT B66	135173SP	XR15_3 SIDE DISCHARGE
	V BELT B71	135171SP	XR15_3 TOP DISCHARGE
12	BEARING KIT ZP 25MM NSK	135101SP	ALL MODELS
13	SHAFT FAN PG STEEL 25mm	1105100SP	XR8,10
	SHAFT FAN PG STEEL 25MM	1105101SP	XR12,14,15,15_3
14	BALL VALVE - 1/2" (CISTERN)	6050911SP	



REPLACEMENT PARTS MANUAL

Date Issued 25-Jul-08	Product Section Details Celair Commercial E.A.C. - Ducted Centrifugal	Section No C7.04
Issue Status D	XR Series 8, 10, 12, 14, 15, 15_3	Page 3

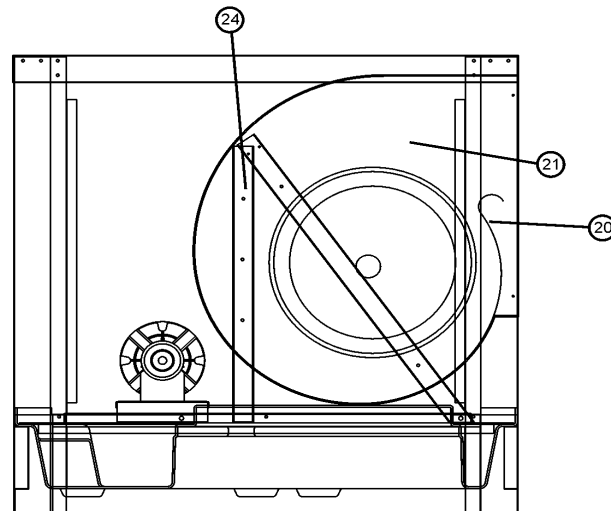
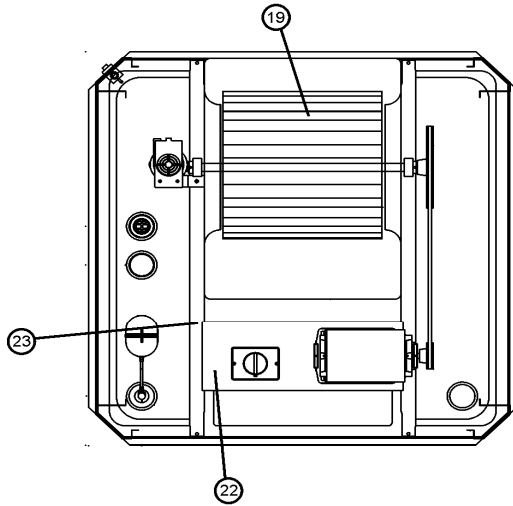
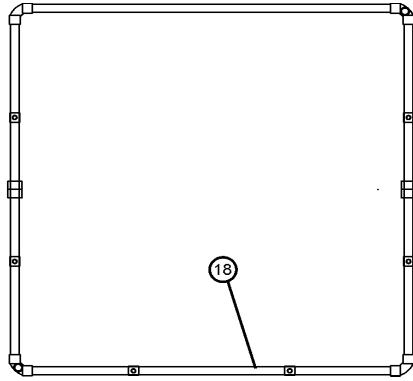



REPLACEMENT PARTS MANUAL

Date Issued 25-Jul-08	Product Section Details Celair Commercial E.A.C. - Ducted Centrifugal	Section No C7.04
Issue Status D	XR Series 8, 10, 12, 14, 15, 15_3	Page 4

ITEM NUMBER	DESCRIPTION	PART NUMBER	COMMENTS
15	BRACKET FLOAT VALVE	1105029SP	
16	COMBINATION DRAIN/WASTE ASSY	1205121SP	
	DRAIN BASE SUB ASSEMBLY	150821SP	
	O RING BS028	150450SP	
	OVERFLOW 40MM PVC	1105359SP	
17	DIALFLOW CONTROL VALVE	6050904SP	
10	PVC ASSEMBLY	2520901SP	XR8,10
	PVC ASSEMBLY	2540901SP	XR12,14,15,15_3
19	BLOWER WHEEL 15" X 15" 25MM	125021SP	XR8, 10
	BLOWER WHEEL 18" X 18" 25MM	125031SP	XR12,14,15,15_3
20	BLOWER CUT OFF PLATE	1205504SP	XR8,10
	BLOWER CUT OFF PLATE	1205509SP	XR12,14,15,15_3
21	SCROLL PLASTIC 15"	156001SP	XR8,10 BOTTOM DISCHARGE
	SCROLL PLASTIC 15"	156005SP	XR8,10 SIDE DISCHARGE
	SCROLL PLASTIC 15"	156010SP	XR8,10 TOP DISCHARGE
	SCROLL PLASTIC 18"	156015SP	XR12,14,15,15_3 BOTTOM DISCHARGE
	SCROLL PLASTIC 18"	156020SP	XR12,14,15,15_3 SIDE DISCHARGE
	SCROLL PLASTIC 18"	156025SP	XR12,14,15,15_3 TOP DISCHARGE
22	MOTOR MOUNTING PLATE	1105007SP	XR8,10
	MOTOR MOUNTING PLATE	1105041SP	XR14,15
	MOTOR MOUNTING PLATE	1105081SP	XR15_3
23	MOTOR SUPPORT CHANNEL LH	1105056SP	XR8,10
	MOTOR SUPPORT CHANNEL LH	1105034SP	XR12,14,15,15_3
	MOTOR SUPPORT CHANNEL RH	1105018SP	XR8,10
	MOTOR SUPPORT CHANNEL RH	1105076SP	XR12,14,15,15_3
24	SCROLL SUPPORT 1 LEFT HAND	1105003SP	XR8,10 BOTTOM DISCHARGE
	SCROLL SUPPORT 1 LEFT HAND	1105001SP	XR8,10 SIDE DISCHARGE
	SCROLL SUPPORT 1 LEFT HAND	1105005SP	XR8,10 TOP DISCHARGE
	SCROLL SUPPORT 1 LEFT HAND	1105035SP	XR12,14,15,15_3 BOTTOM DISCHARGE
	SCROLL SUPPORT 1 LEFT HAND	1105037SP	XR12,14,15,15_3 SIDE DISCHARGE
	SCROLL SUPPORT 1 LEFT HAND	1105039SP	XR12,14,15,15_3 TOP DISCHARGE
	SCROLL SUPPORT 2 LEFT HAND	1105004SP	XR8,10 BOTTOM DISCHARGE
	SCROLL SUPPORT 2 LEFT HAND	1105002SP	XR8,10 SIDE DISCHARGE
	SCROLL SUPPORT 2 LEFT HAND	1105006SP	XR8,10 TOP DISCHARGE
	SCROLL SUPPORT 2 LEFT HAND	1105015-3SP	XR12,14,15,15_3 BOTTOM DISCHARGE
	SCROLL SUPPORT 2 LEFT HAND	1105038SP	XR12,14,15,15_3 SIDE DISCHARGE
	SCROLL SUPPORT 2 LEFT HAND	1105040SP	XR12,14,15,15_3 TOP DISCHARGE
	SCROLL SUPPORT 1 RH/LH	1105057SP	XR8,10 BOTTOM DISCHARGE
	SCROLL SUPPORT 1 RH/LH	1105059SP	XR8,10 SIDE DISCHARGE
	SCROLL SUPPORT 1 RH/LH	1105061SP	XR8,10 TOP DISCHARGE
	SCROLL SUPPORT 1 RH/LH	1105064SP	XR12,14,15,15_3 BOTTOM DISCHARGE
	SCROLL SUPPORT 1 RH/LH	1105066SP	XR12,14,15,15_3 SIDE DISCHARGE
	SCROLL SUPPORT 1 RH/LH	1105068SP	XR12,14,15,15_3 TOP DISCHARGE
	SCROLL SUPPORT 2 RH/LH	1105058SP	XR8,10 BOTTOM DISCHARGE



REPLACEMENT PARTS MANUAL

Date Issued 25-Jul-08	Product Section Details Celair Commercial E.A.C. - Ducted Centrifugal	Section No C7.04
Issue Status D	XR Series 8, 10, 12, 14, 15, 15_3	Page 5

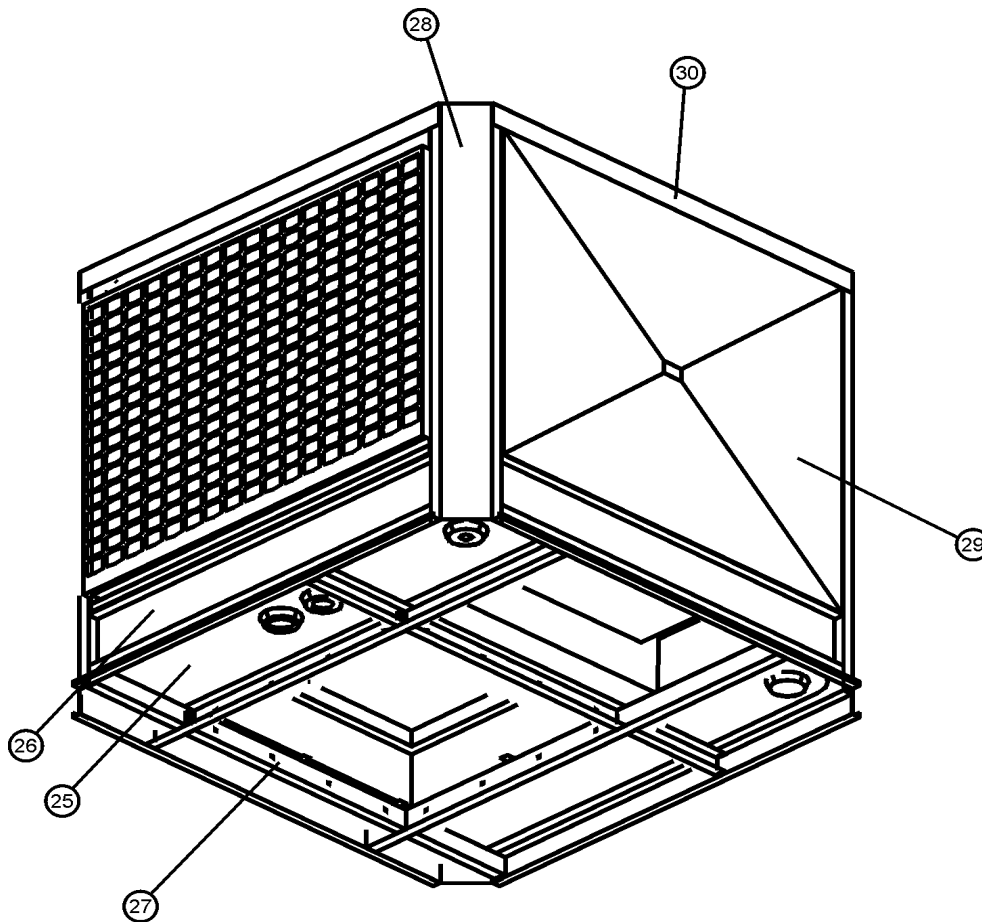



REPLACEMENT PARTS MANUAL

Date Issued 25-Jul-08	Product Section Details Celair Commercial E.A.C. - Ducted Centrifugal	Section No C7.04
Issue Status D	XR Series 8, 10, 12, 14, 15, 15_3	Page 6

ITEM NUMBER	DESCRIPTION	PART NUMBER	COMMENTS
	SCROLL SUPPORT 2 RH/LH	1105060SP	XR8,10 SIDE DISCHARGE
	SCROLL SUPPORT 2 RH/LH	1105062SP	XR8,10 TOP DISCHARGE
	SCROLL SUPPORT 2 RH/LH	1105065SP	XR12,14,15,15_3 BOTTOM DISCHARGE
	SCROLL SUPPORT 2 RH/LH	1105067SP	XR12,14,15,15_3 SIDE DISCHARGE
	SCROLL SUPPORT 2 RH/LH	1105069SP	XR12,14,15,15_3 TOP DISCHARGE
25	BASE VACUUM FORMED	155022SP	XR8,10 BOTTOM DISCHARGE
	BASE VACUUM FORMED	155021SP	XR8,10 TOP,SIDE DISCHARGE
	BASE VACUUM FORMED	155024SP	XR12,14,15,15_3 BOTTOM DISCHARGE
	BASE VACUUM FORMED	155023SP	XR12,14,15,15_3 TOP,SIDE DISCHARGE
26	SIDE SKIRT	1105017SP	XR8,10
	SIDE SKIRT	1105033SP	XR12,14,15,15_3
	SIDE SKIRT	1105025SP	XR8,10 SIDE DISCHARGE FRONT
	SIDE SKIRT	1105072SP	XR12,14,15,15_3 SIDE DISCHARGE FRONT
27	H FRAME CHANNEL A	1104038SP	XR8,10
	H FRAME CHANNEL A	1105163SP	XR12,14,15,15_3
	H FRAME CHANNEL B	1104039SP	XR8,10
	H FRAME CHANNEL B	1105164SP	XR12,14,15,15_3
28	CORNER POST REAR LEFT HAND	1105107SP	XR8,10 TOP,BOTTOM DISCHARGE
	CORNER POST REAR LEFT HAND	1105188SP	XR8,10 SIDE DISCHARGE
	CORNER POST RIGHT HAND REAR	1105184SP	XR8,10 TOP,BOTTOM DISCHARGE
	CORNER POST REAR LEFT HAND	1105188SP	XR8,10 SIDE DISCHARGE
	CORNER POST LH REAR/RH FRONT	1105187SP	XR8,10 SIDE DISCHARGE
	CORNER POST LEFT HAND REAR	1105188SP	XR8,10 TOP,BOTTOM DISCHARGE
	CORNER POST DIAFLO FRONT LH	1105185SP	XR8,10 TOP,BOTTOM DISCHARGE
	CORNER POST DIAFLO FRONT LH	1105186SP	XR8,10 SIDE DISCHARGE
	CORNER POST REAR RIGHT HAND	1105031SP	XR12,14
	CORNER POST REAR RIGHT HAND	1105031SP	XR15 BOTTOM, TOP DISCHARGE
	CORNER POST REAR LEFT HAND	1105045SP	XR15 SIDE DISCHARGE
	CORNER POST FRONT RIGHT HAND	1105032SP	XR12,14
	CORNER POST FRONT RIGHT HAND	1105032SP	XR15 SIDE DISCHARGE
	CORNER POST REAR LEFT HAND	1105045SP	XR15 BOTTOM, TOP DISCHARGE
	CORNER POST DIAFLO FRONT LH	1105047SP	XR12,14
	CORNER POST DIAFLO FRONT LH	1105047SP	XR15 SIDE DISCHARGE
	CORNER POST DIAFLO FRONT LH	1105046SP	XR15 TOP, DISCHARGE DISCHARGE
29	WASHER BACK	1105084SP	XR12,14,15,15_3
	PANEL DROP FILL	1105015SP	XR8 TOP,BOTTOM DISCHARGE
	PANEL DROP FILL	1105015SP	XR8 SIDE DISCHARGE
	PANEL DROP FILL	1105015SP	B10 TOP,BOTTOM DISCHARGE
	PANEL DROP FILL	1105054SP	XR12,14 BOTTOM, TOP DISCHARGE
	PANEL DROP FILL	1105054SP	XR12,14 SIDE DISCHARGE
	PANEL DROP FILL	1105054SP	XR15 BOTTOM, TOP DISCHARGE
	PANEL DROP FILL	1105020SP	XR8,10 SIDE DISCHARGE
	PANEL DROP FILL	1105070SP	XR12,14,15,15_3



REPLACEMENT PARTS MANUAL

Date Issued 25-Jul-08	Product Section Details Celair Commercial E.A.C. - Ducted Centrifugal	Section No C7.04
Issue Status D	XR Series 8, 10, 12, 14, 15, 15_3	Page 7

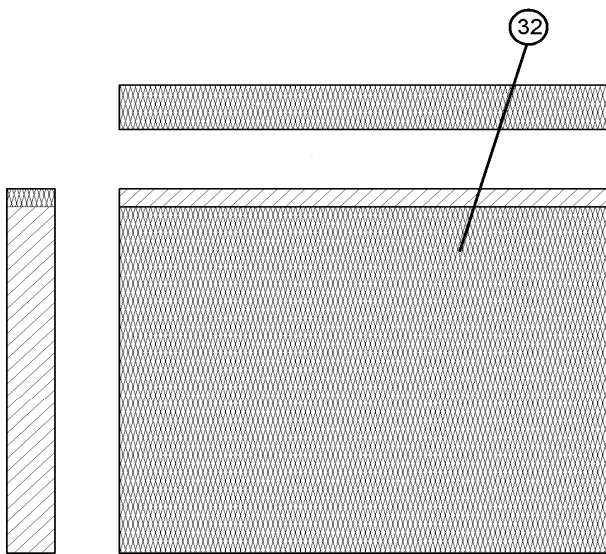
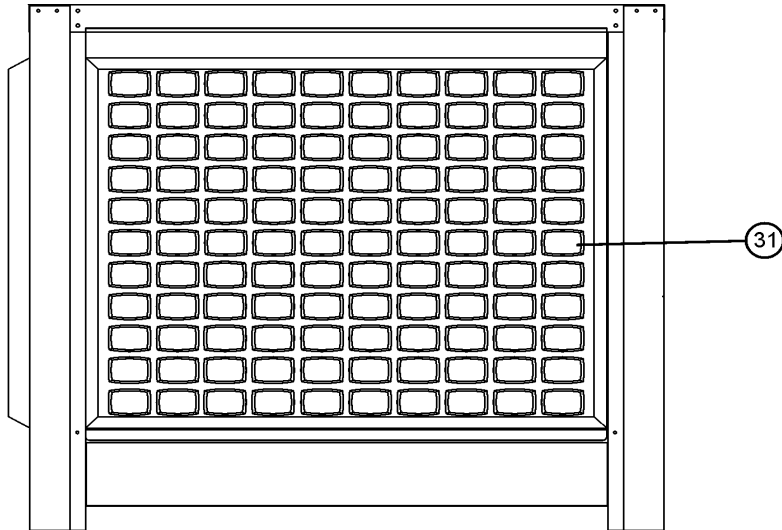

CELKEK

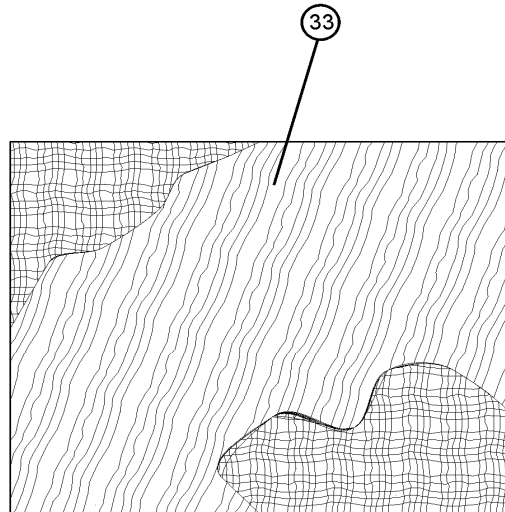

ASPEN



REPLACEMENT PARTS MANUAL

Date Issued 25-Jul-08	Product Section Details Celair Commercial E.A.C. - Ducted Centrifugal	Section No C7.04
Issue Status D	XR Series 8, 10, 12, 14, 15, 15_3	Page 8

ITEM NUMBER	DESCRIPTION	PART NUMBER	COMMENTS
30	LID COOLER BOX		XR8,10 BOTTOM DISCHARGE
	LID COOLER BOX	1105190SP	XR8,10 SIDE DISCHARGE
	LID COOLER BOX	1105191SP	XR8,10 TOP DISCHARGE
	LID COOLER BOX	1105085SP	XR12,14,15,15_3 BOTTOM DISCHARGE
	LID COOLER BOX	1105086SP	XR12,14,15,15_3 SIDE DISCHARGE
	LID COOLER BOX	1105087SP	XR12,14,15,15_3 TOP DISCHARGE
31	DECORATIVE PANEL	2522201SP	XR8,10
	DECORATIVE PANEL	2532201SP	XR12,14,15,15_3
	RIVET PLASTIC 5MM	130070SP	
32	CLIP CANOE RAISED HEAD	130448SP	
	FILTERCOOL PAD	150610SP	XR8,10
33	FILTERCOOL PAD	150540SP	XR12,14,15,15_3
	DECORATIVE/FILTERCOOL PANEL	2522202SP	XR8,10
	DECORATIVE/FILTERCOOL PANEL	2532202SP	XR12,15
	FILTER PAD ASPEN	150456SP	XR8,10
	FILTER PAD ASPEN	150455SP	XR12,14,15,15_3
	DECORATIVE FILTER PAD PANEL	2522203SP	XR8,10
	DECORATIVE FILTER PAD PANEL	2532203SP	XR12,15
	PAD RETAINING CAGE A	2520101SP	XR8,10
	PAD RETAINING CAGE B	2520102SP	XR8,10
	PAD RETAINING CAGE A	2540101SP	XR12,14,15,15_3
	PAD RETAINING CAGE B	2540102SP	XR12,14,15,15_3