



UGEARS®

Set of Additions to the model «Truck UGM-11.»
Набір доповнень до моделі «Вантажівка UGM-11».

DEU Erweiterungs-Set für Modell „Lastkraftwagen UGM-11“. FRA Ensemble d'éléments complémentaires pour le camion UGM-11.
POL Zestaw dodatków kompatybilnych z modelem Ciężarówka UGM-11. SPA Conjunto de las adiciones para el modelo del camión UGM-11. ITA Il completo dei supplementi per il modello "Camion UGM-11". RUS Набор дополнений к модели "Грузовик UGM-11".
JAP トラックUGM-11の追加セット KOR 트럭UGM-11 부가 상품 CHI "UGM-11卡车周边套" 模型

Assembly instructions
Інструкція зі складання

DEU Aufbauanleitung. FRA Notice d'assemblage. POL Instrukcja montażu.
SPA Instrucciones de montaje. ITA Istruzioni di montaggio. RUS Инструкция по сборке.
JAP 組み立て説明書 KOR 조립 설명서. CHI 装配说明书



p. 4



p. 36



p. 66

ENG

Assembly instructions:
Remove model parts from the hanger board as illustrated below. Careful not to break parts. If a part does not remove easily, carefully cut it out with a knife. This model is intended for self-assembly without glue. If you have difficulty installing the axles, try waxing them with a regular candle. All moving parts can also be waxed during assembly to reduce friction when operating the model.

UKR

Інструкція зі складання:
Витягніть з дошки позначени на схемі деталі. Намагайтеся їх не зламати. Якщо деталь не виймається, надсічіть перемички ножем. Конструкція збирається без клею. У разі виникнення труднощів з протягуванням зубчистки (вісі) в отвір, потріть зубчистку об звичайну свічку. Також можна змастити свічкою всі деталі механізму, що рухаються, щоб зменшити тертя при обертанні.

DEU

Aufbauanleitung:
Bitte die in der Zeichnung angegebenen Teile aus der Platte herausnehmen. Versuchen Sie bitte diese nicht zu brechen. Wenn sich ein Teil nicht herausnehmen lässt, schneiden Sie die Stege mit dem Messer leicht an. Das Modell wird ohne Klebstoffe zusammengesetzt. Lässt sich eine Achse nur schwer in eine Öffnung einführen, reiben Sie diese mit einer Kerze etwas ein. Für besseres Gleiten schmieren Sie alle beweglichen Teile mit einer Kerze.

FRA

Notice d'assemblage:
Faites sortir de la planche les pièces comme indiquées sur le schéma. Tâchez de ne pas les casser. Si la pièce ne sort pas, incisez les collages/fixations avec un couteau. La construction est à assembler sans colle. Si il est difficile d'introduire l'axe en bois dans l'orifice, frottez au préalable l'axe ou les pièces contre une bougie. Pour améliorer le glissement, traitez les pièces de frottement mobiles du mécanisme avec une bougie au cours d'assemblage.

POL

Instrukcja montażu:
Delikatnie wyciągnij z deseczki wskazane w schemacie detale, starając się nie połamać elementów. Jeśli detal nie poddaje się, podetnij wiązadła nożem. Konstrukcja składa się bez kleju. Jeśli napotkasz trudności z instalacją drewnianej osi w otwór, potrzyj na początku oś lub detale o woskową świecę. Dla lepszego poślizgu polecano smarowanie ruchomych części mechanizmu zwykłą świecą podczas montażu.

SPA

Instrucciones de montaje:
Saque de la tabla las piezas marcadas en el esquema. Trate de no romperlas. Si una pieza no se saca, haga una incisión. La construcción va sin pegamento. Si tiene dificultades con la instalación del eje de madera en un agujero, frote primero el eje o las piezas contra una vela. Para un mejor deslizamiento, lubrique durante el montaje las piezas móviles del mecanismo con una vela común.

ITA

Istruzioni di montaggio:
Estrarre dal telaio i particolari indicati nello schema. Fare attenzione a non romperli. Se un particolare non si stacca, tagliare delicatamente gli elementi di collegamento con un coltello. L'assieme viene realizzato senza colla. In caso di difficoltà nell'inserimento di un perno in legno, è necessario sfregare il perno o il particolare con un po' di cera. Per uno scorrimento migliore incerare le parti mobili del meccanismo durante l'assemblaggio.

RUS

Инструкция по сборке:
Внимайте из доски обозначенные на схеме детали. Старайтесь их не сломать. Если деталь не извлекается, надрежьте перемычки ножом. Конструкция собирается без клея. Если возникли трудности с установкой деревянной оси, перед установкой потрите детали об обычную свечу. Для лучшего скольжения смазывайте движущиеся детали механизма обычной свечой во время сборки.

JAP

組み立て説明書:
部品に傷をつけないように注意しながらボードから外してください。部品が外れにくい場合は連結部分をカッターで切ってから外すと外しやすいです。本製品は、接着剤がなくても組み立てができるように設計されています。もしアクスル(駆動部)が、歯車の動きがにぶい場合は、口ウソクをアクスルに塗ってください。全ての駆動部分は製品を動かす時、滑らかに動くように潤滑剤である口ウソクを塗りながら組み立てます。

KOR

조립 설명:
부품이 손상되지 않도록 주의하여 보드에서 떼어냅니다. 만약 부품이 잘 떨어지지 않으면 연결 부분을 칼로 절단 한 후 떼어 내면 쉽게 떼어 낼 수 있습니다. 본 제품은 접착제가 없이 조립이 가능하도록 설계되어 있습니다. 만약 축이 잘 끼워지지 않는 경우 양초를 축에 바른 후 끼워 보세요. 모든 구동 부위는 제품 구동 시 원활한 작동이 가능하도록 조립 과정에서 윤활제(양초) 양초를 발라 주세요.

CHI

装配说明
将模型部件按插图所示,从胶合板取下。小心不要损坏件。如果取下时候有难度,用小刀小心的切割连接点。这个产品不需要胶水粘接。如果安装转轴的时候有难度,请用普通的蜡加以润滑。所有的转动部分也需要打蜡润滑。



ENG Do not use a lighted candle! **UKR** Не підпалювати! **DEU** Nicht azünden!
FRA Ne pas brûler! **POL** Nie podpalać! **SPA** ¡No encender! **ITA** Non dare fuoco!
RUS Не поджигать! **JAP** 火のついた口ウソクの使用はお止めください!
KOR 불이 붙은 초를 이용하지 마세요! **CHI** 请勿点燃, 请勿靠近火源!



ENG Caution! Axles have sharp points! **UKR** Обережно! Гострі деталі!
DEU Vorsicht! Spitze Teile! **FRA** Attention: certaines pièces sont pointues!
POL Ostrożnie! Ostre części! **SPA** ¡Atención! Piezas afiladas! **ITA** Attenzione! Particolari appuntiti! **RUS** Осторожно! Острые детали!
JAP アクスル(駆動部)の鋭い部分にご注意ください。 **KOR** 축의 뾰족한 부분에 주의하세요! **CHI** 注意! 尖尖锐部件

ENG Customer support **UKR** Служба підтримки **DEU** Kundendienst **FRA** Service client **POL** Wsparcie klienta
SPA Servicio al cliente **ITA** Servizio di supporto **RUS** Служба поддержки **JAP** お客様窓口 **KOR** 고객지원 **CHI** 客户支持

UKR Умовні позначення. ENG Symbols. DEU Legende. FRA Légende. POL Oznaczenia umowne.
SPA Leyenda. ITA Legenda. RUS Условные обозначения. JAP 記号. KOR 기호. CHI 图标含义.



ENG Wax the part with a regular candle (rub with a candle). **UKR** Змастіть деталь звичайною свічкою (потріть об свічку). **DEU** Reiben Sie das Teil mit einer einfachen Kerze etwas ein. **FRA** Lubrifiez la pièce avec une bougie ordinaire (frottez contre la bougie). **POL** Przesmaruj zwykłą świecą. **SPA** ENGrase la pieza con una vela común (frote con una vela). **ITA** Incerare il componente (Sfregare con la cera). **RUS** Смажьте деталь обычной свечкой (потрите о свечку). **JAP** された部分に潤滑剤としてろうソクを塗ってください。 **KOR** 표시된 부분에 윤활을 위해 초를 칠해 주세요. **CHI** 用普通蜡烛涂抹润滑部件



ENG Break off or cut out. **UKR** Відламайте або відріжте. **DEU** Abbrechen oder Abschneiden. **FRA** Coupez ou cassez. **POL** Odłam lub odetnij. **SPA** Rompa o corte. **ITA** Staccare o tagliare. **RUS** Отломайте или отрежьте. **JAP** 切ってください。 **KOR** 잘라내 주세요. **CHI** 切斷



ENG Pay attention. Check position of the part. **UKR** Зверніть увагу. Перевірте розташування елемента. **DEU** Bitte Beachten. Prüfen Sie die Einbaulage des Elementes. **FRA** Faites attention. Vérifiez la disposition de l'élément. **POL** Zwróć uwagę. Sprawdź lokalizację elementu. **SPA** Atención. Compruebe la situación del elemento. **ITA** Prestare attenzione. Controllare la posizione del componente. **RUS** Обратите внимание. Проверьте расположение элемента. **JAP** 方向及び位置に注意して組み立て下さい。 **KOR** 방향 또는 위치에 주의해서 조립해 주세요. **CHI** 注意! 检查部件方向和位置



ENG Spare parts. **UKR** Запасні деталі. **DEU** Ersatzteile. **FRA** Pièces de rechange. **POL** Części zamienne. **SPA** Piezas de repuesto. **ITA** Pezzi di ricambio. **RUS** Запасные детали. **JAP** 予備部品。 **KOR** 여유 부품입니다. **CHI** 备用件。



ENG Cut crosspieces before removing the part from the board. **UKR** Обріжте перемички перед витяганням деталі. **DEU** Schneiden Sie die Stege ein, bevor Sie das Teil rausnehmen. **FRA** Découpez les fixations avant de retirer les pièces. **POL** Obetnij uszczelnienia przed wyjmowaniem elementu. **SPA** Corte los puentes antes de extraer la pieza. **ITA** Tagliare gli elementi di collegamento prima di estrarre i particolari. **RUS** Обрежьте перемычки перед выниманием детали. **JAP** 部品を外す前に連結部分を切ってください。 **KOR** 부품을 떼어내기 전, 연결 부분을 잘라 주세요. **CHI** 在取下部件前切斷连接点



ENG Cut crosspieces before removing the part from the board. **UKR** Обріжте перемички перед витяганням деталі. **DEU** Schneiden Sie die Stege ein, bevor Sie das Teil rausnehmen. **FRA** Découpez les fixations avant de retirer les pièces. **POL** Obetnij uszczelnienia przed wyjmowaniem elementu. **SPA** Corte los puentes antes de extraer la pieza. **ITA** Tagliare gli elementi di collegamento prima di estrarre i particolari. **RUS** Обрежьте перемычки перед выниманием детали. **JAP** 部品を外す前に連結部分を切ってください。 **KOR** 부품을 떼어내기 전, 연결 부분을 잘라 주세요. **CHI** 在取下部件前切斷连接点



ENG Axle. **UKR** Вісь. **DEU** Achse. **FRA** Axe. **POL** Oś. **SPA** Eje. **ITA** Perno. **RUS** Ось. **JAP** アクスル. **KOR** 축. **CHI** 軸承.

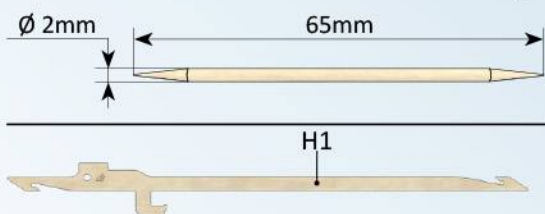

ENG This is not a structural component; it is a tool for measurement and assembly. **UKR** Це не деталь конструкції, а допоміжний інструмент для складання або вимірювання відстаней. **DEU** Es ist kein Teil der Konstruktion, sondern ein Hilfselement für den Zusammenbau oder für das Messen der Abstände. **FRA** Cette pièce ne fait pas partie de la construction mais constitue un outil annexe pour l'assemblage ou la mesure des distances. **POL** To nie detal konstrukcji, a pomocnicze narzędzie dla montażu i wymiaru odległości. **SPA** No es una pieza de la construcción sino un instrumento auxiliar para montar o para medir distancias. **ITA** Non è un componente del modello, ma un'attrezzatura aggiuntiva per il montaggio o il rilievo delle quote. **RUS** Это не деталь конструкции, а вспомогательный инструмент для сборки или измерения расстояний. **JAP** この部品は完成時の部品ではなく、組み立てをサポートしたり測定する道具です。 **KOR** 이 부품은 조립을 위한 부품이 아니고 조립을 돕거나 측정을 위한 도구입니다. **CHI** 这不是装配零部件, 是一种测量及安装辅助工具。

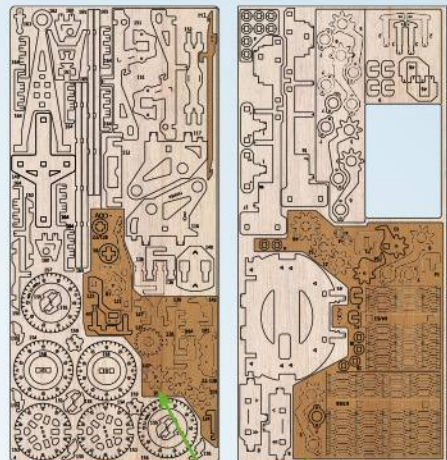

ENG Tanker. UKR Цистерна. DEU Tankwagen. FRA Citerne.
POL Cysterne. SPA Cisterna. ITA Autocisterna. RUS Цистерна.
JAP タンカー. KOR 캔운반차. CHI 罐车

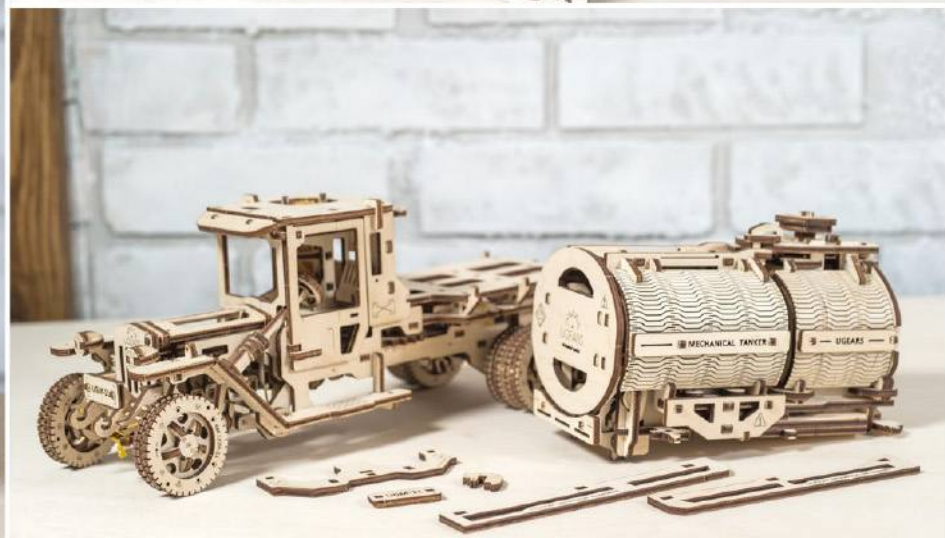
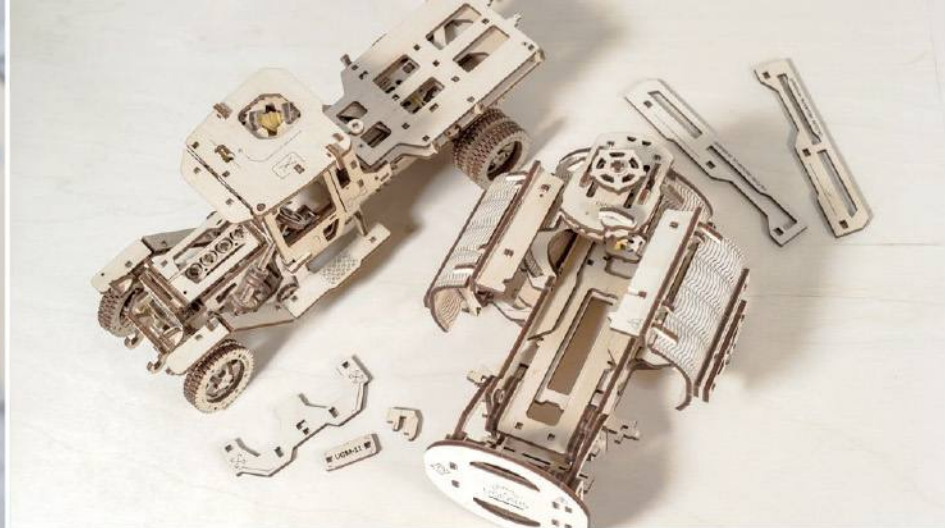

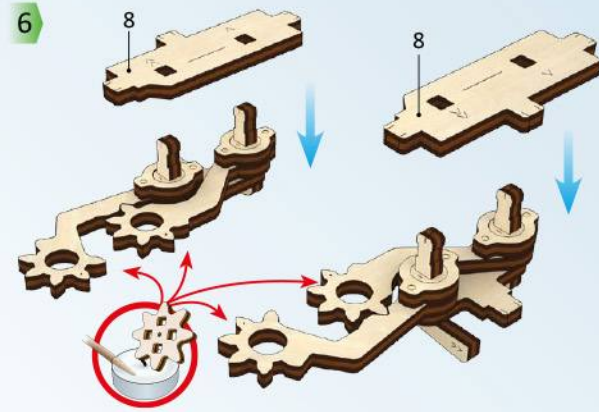
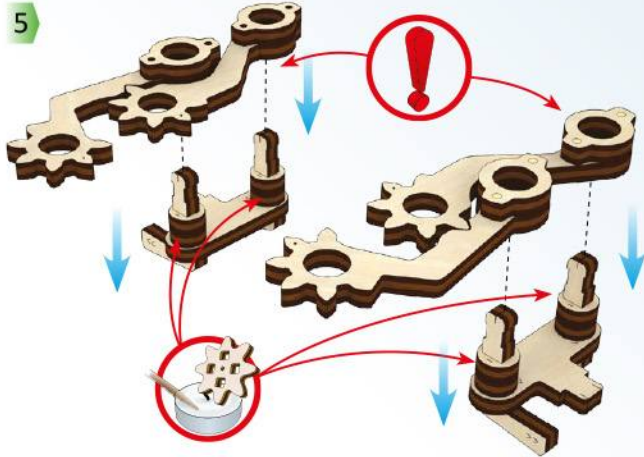
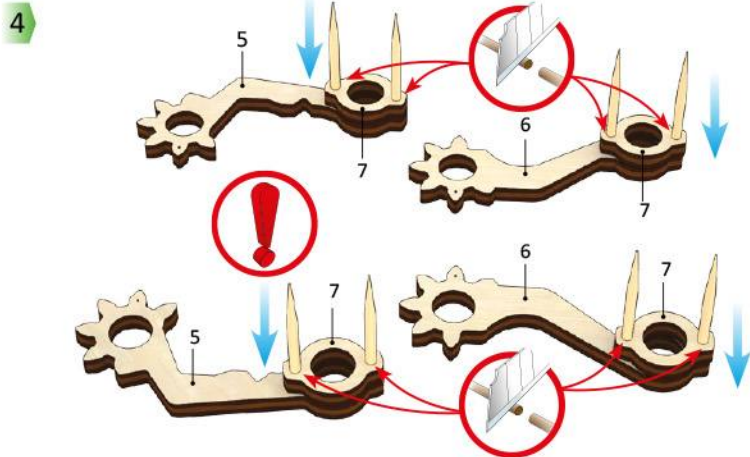
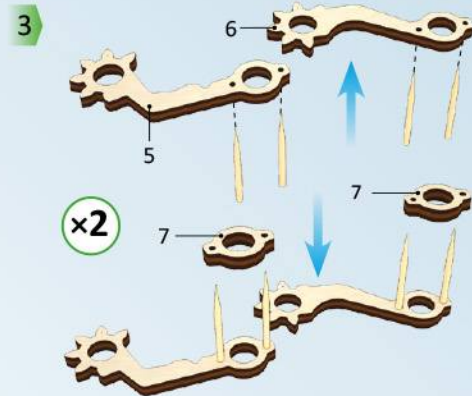
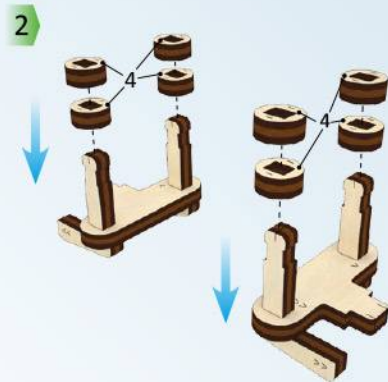
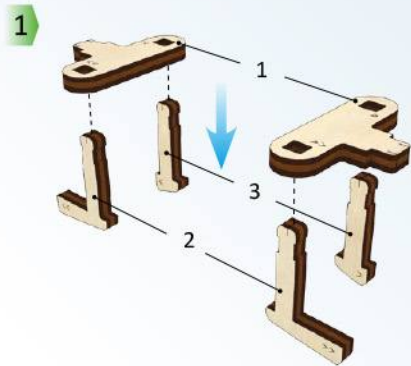
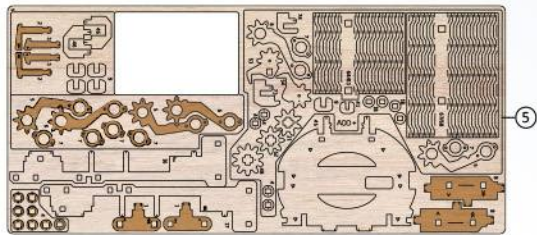

Mechanical models

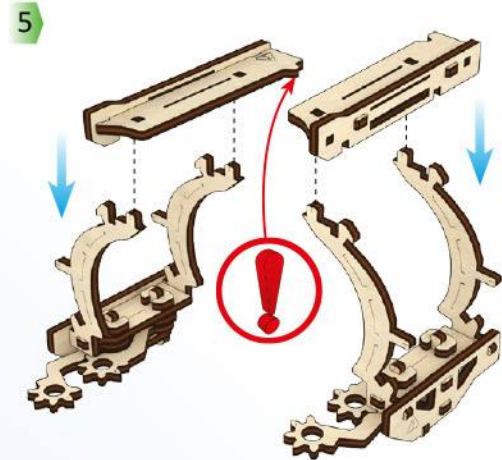
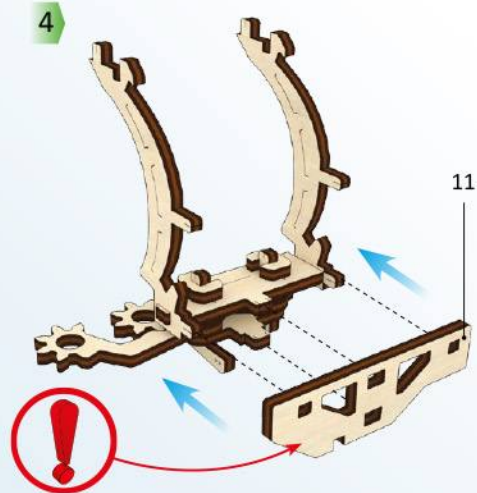
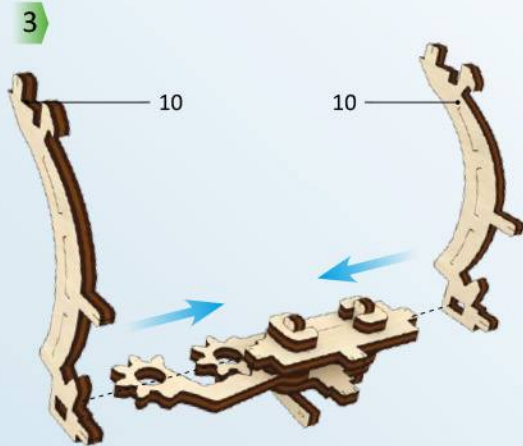
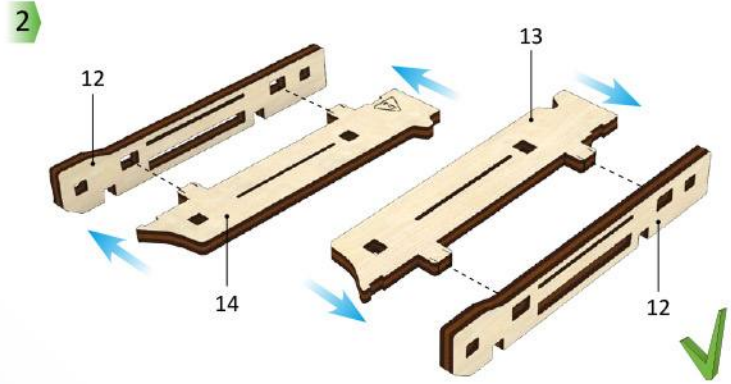
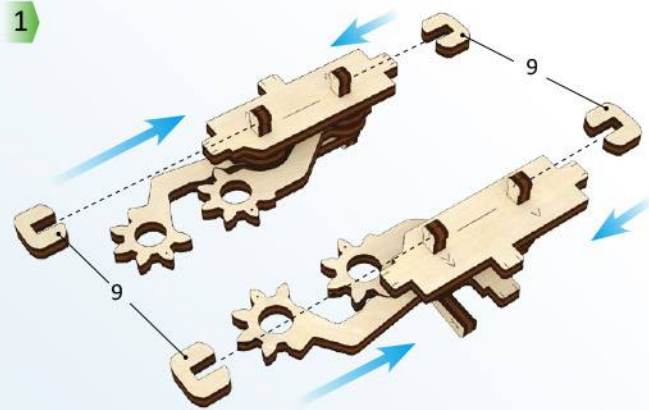
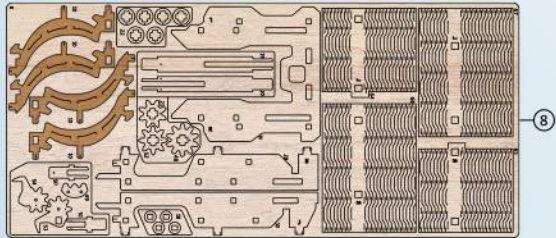
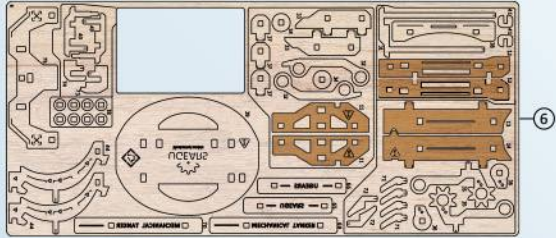
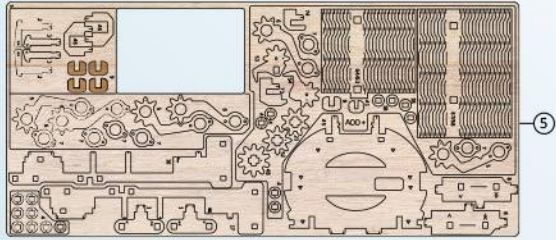

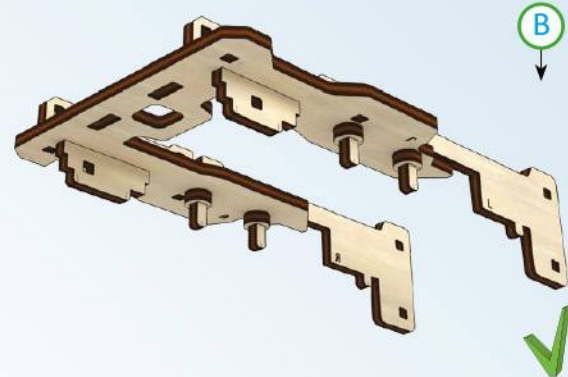
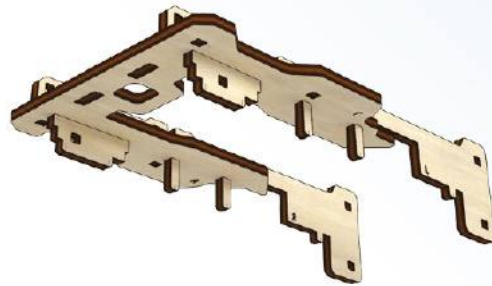
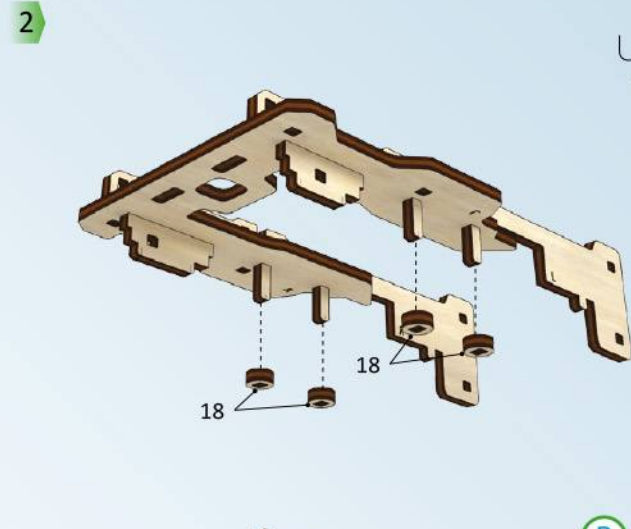
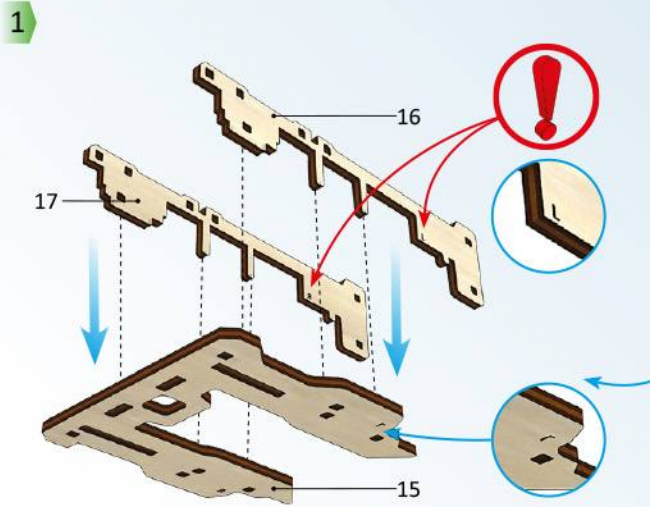
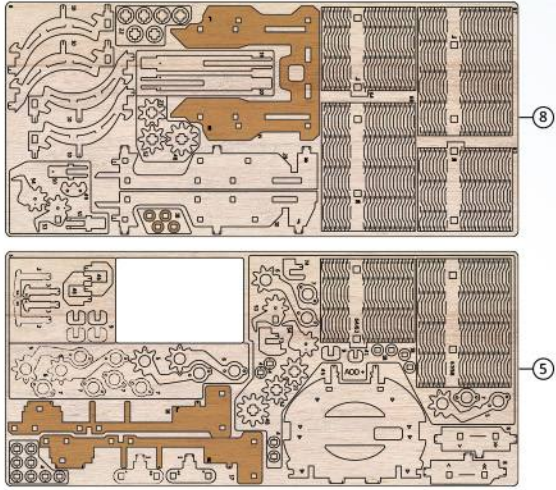

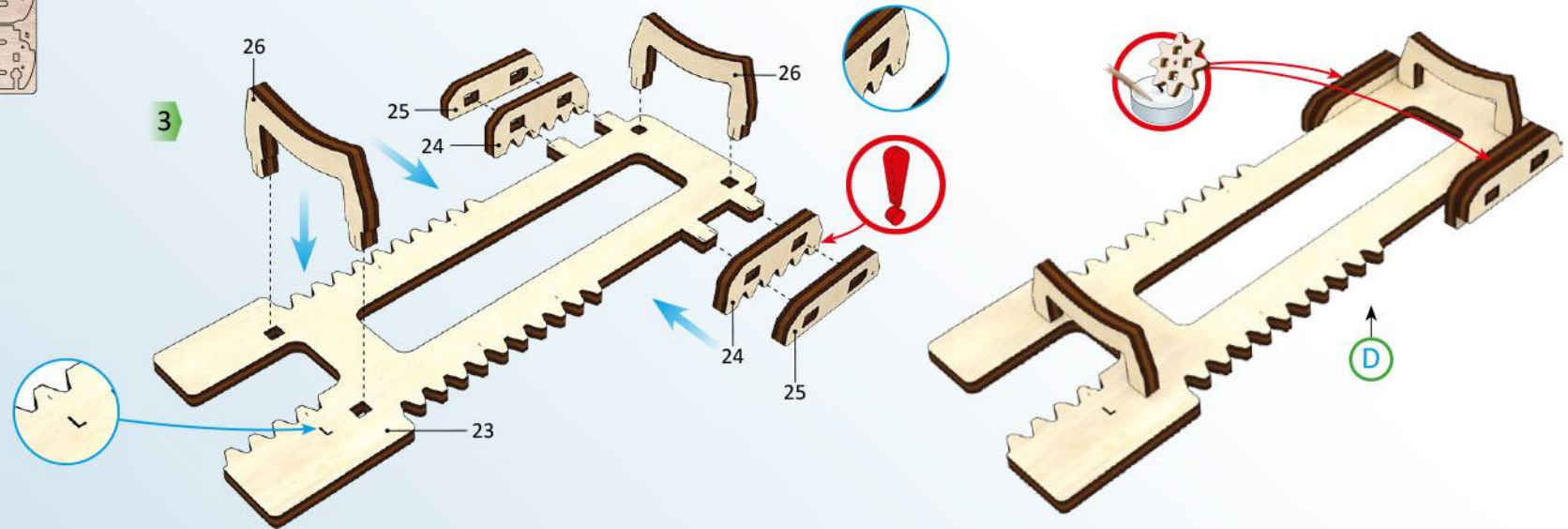
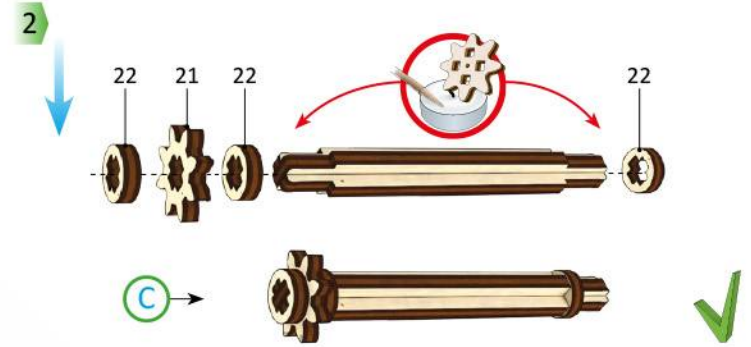
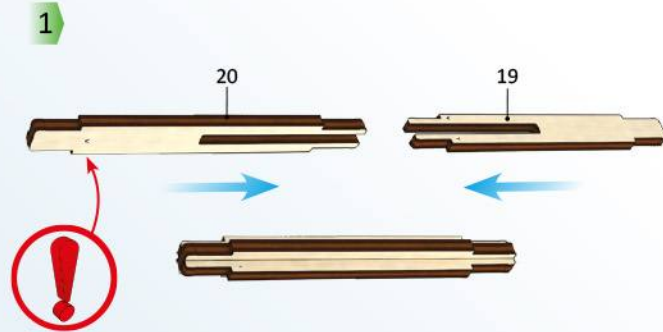
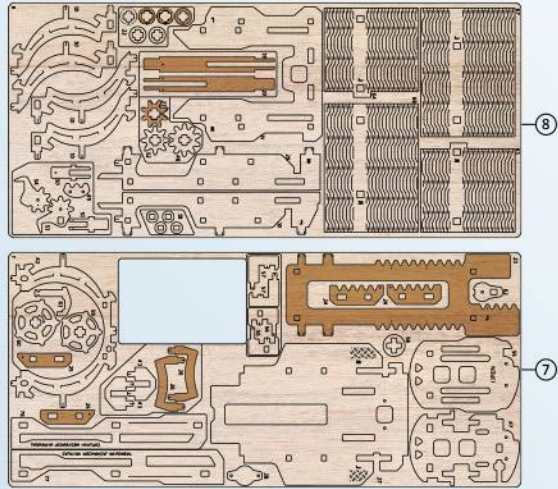

1

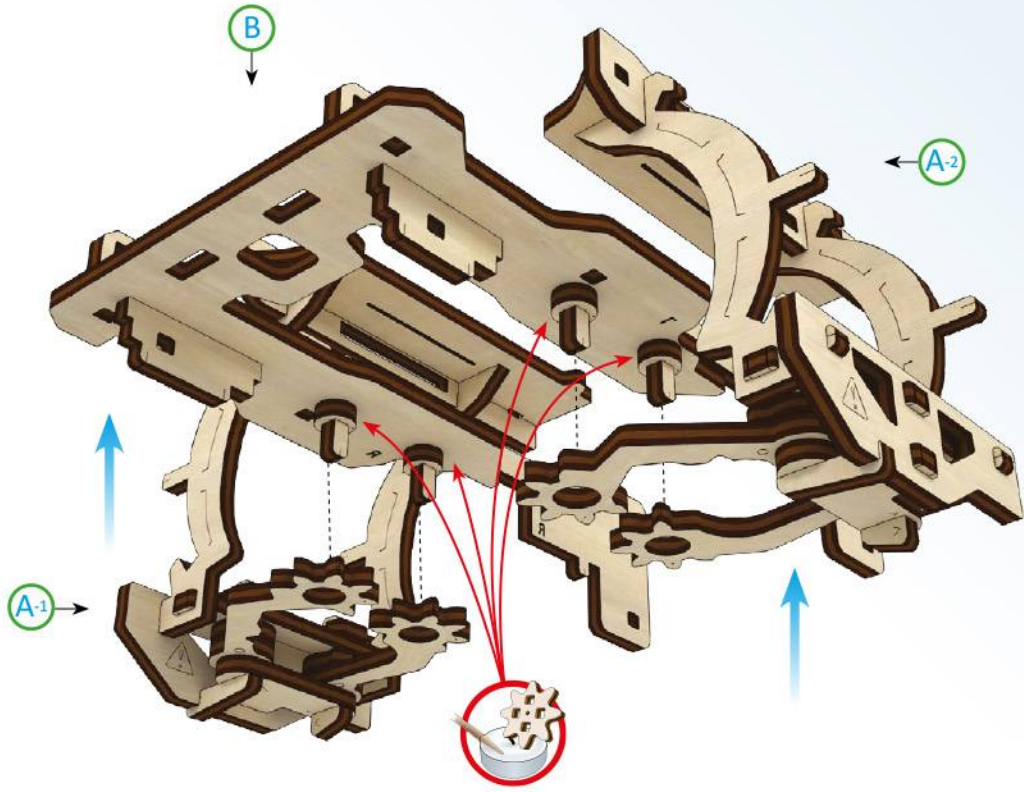

2



3

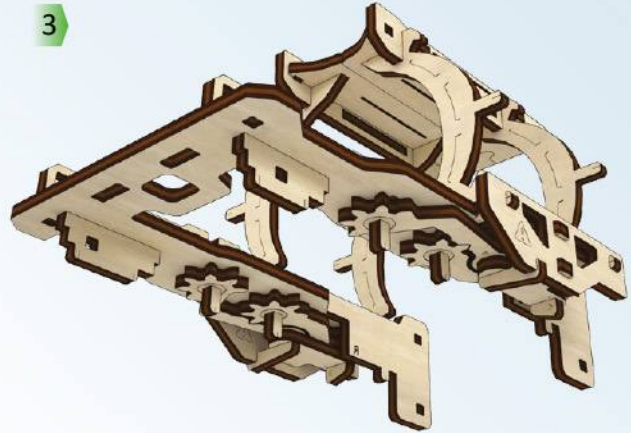

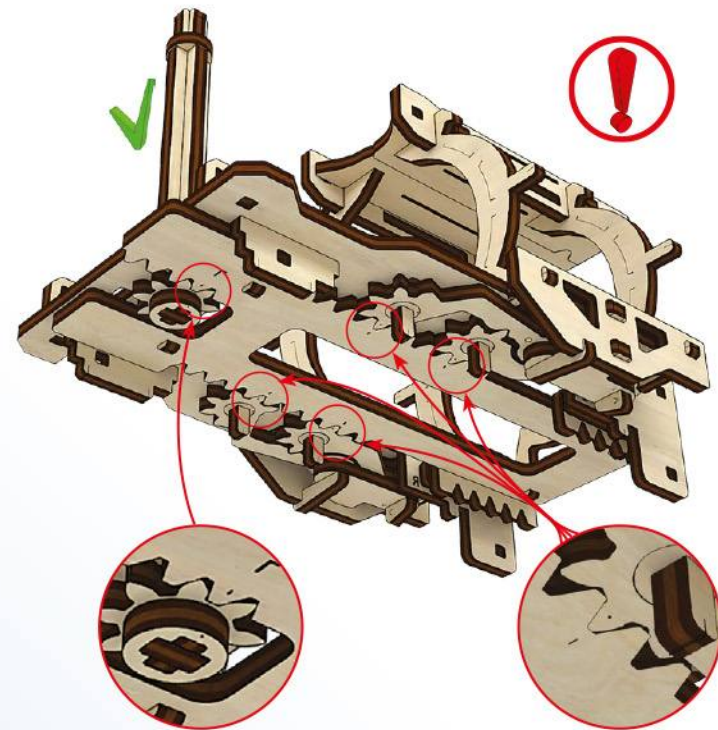
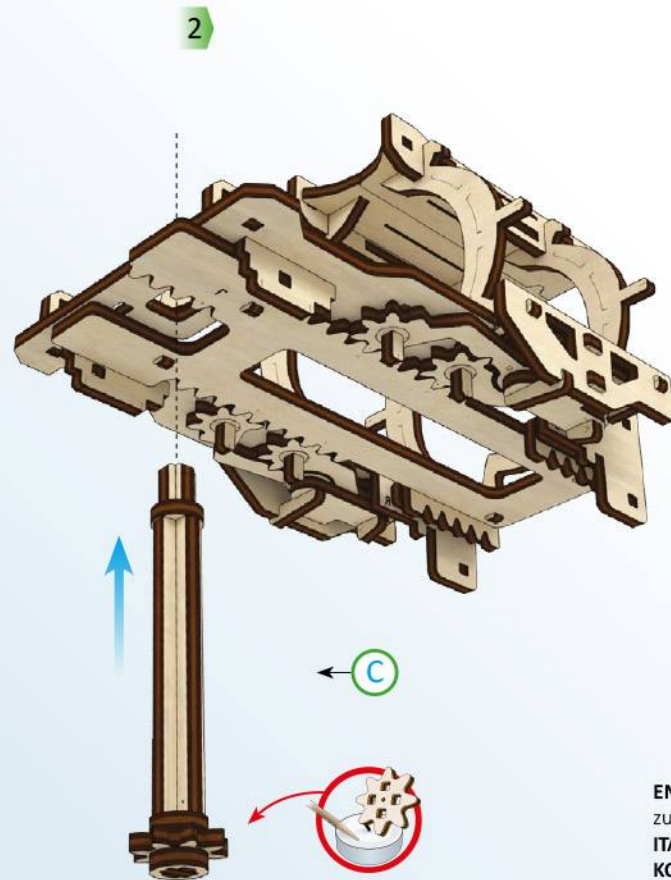
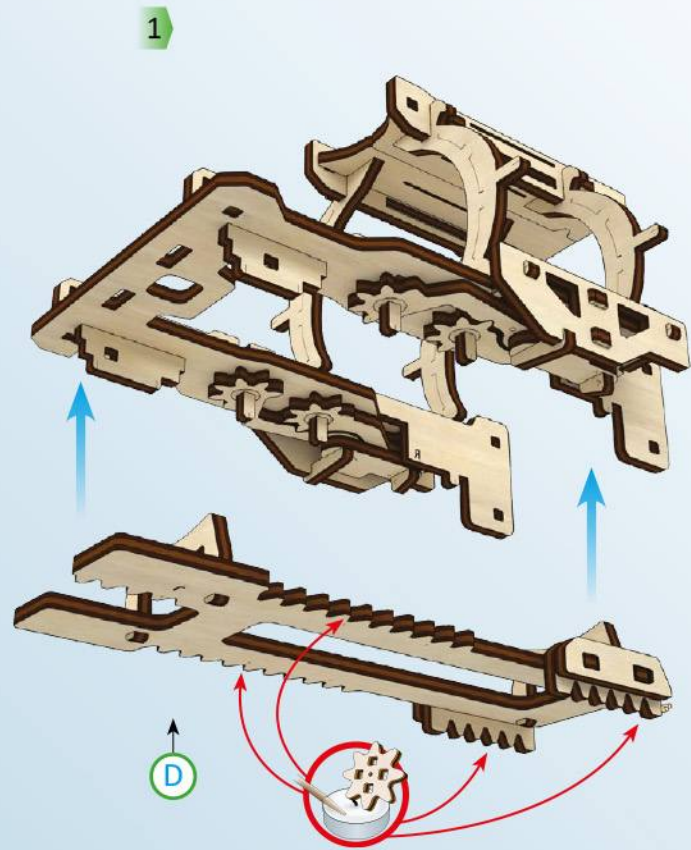

ENG Put the marks together. UKR Поєднайте мітки. DEU Führen Sie die Markierungen zusammen. FRA Alignez les marques. POL Złóżyc znaki. SPA Juntará los las marcas. ITA Unire ed assemblare gli incastri. RUS Совместите метки. JAP マークを揃えます。KOR 표시를 맞춰주세요. CHI 重合标志。

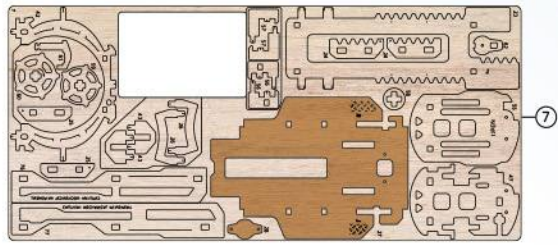

1

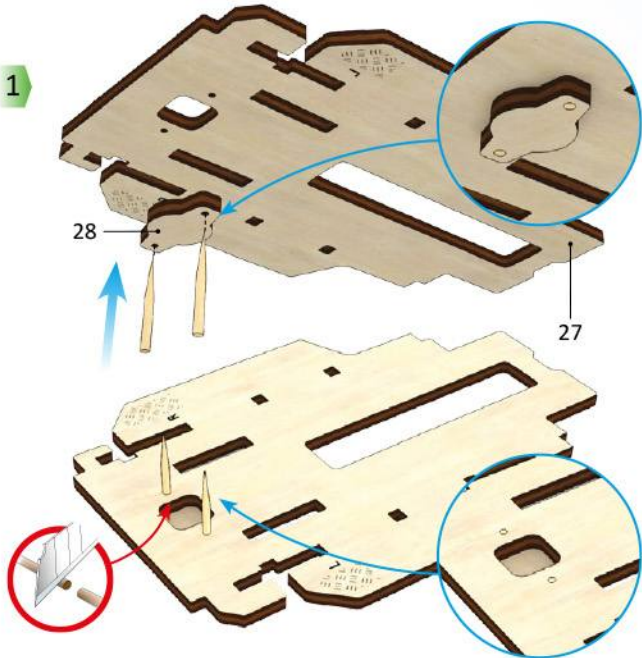

2

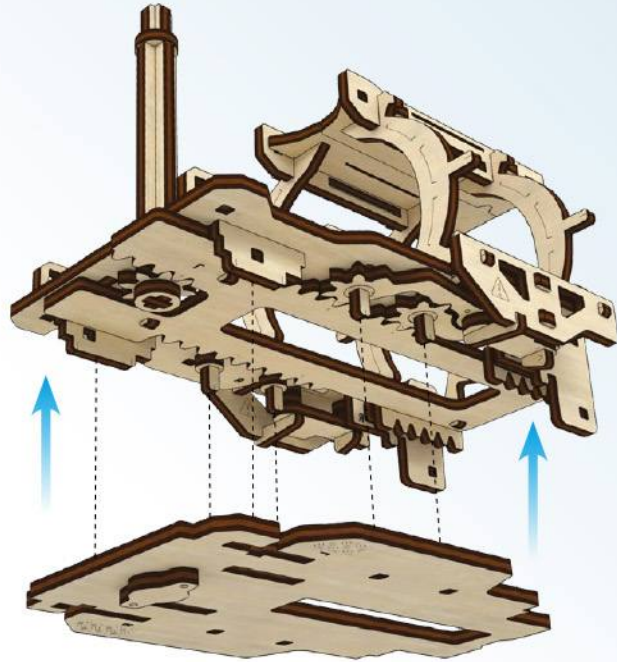

3

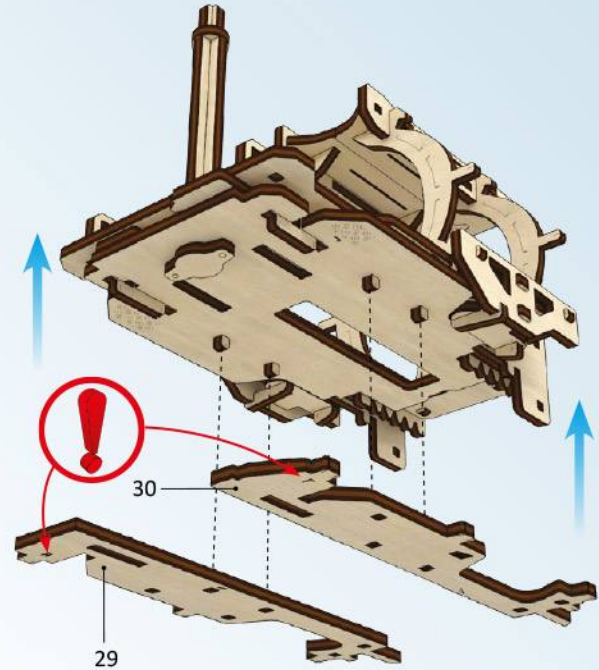
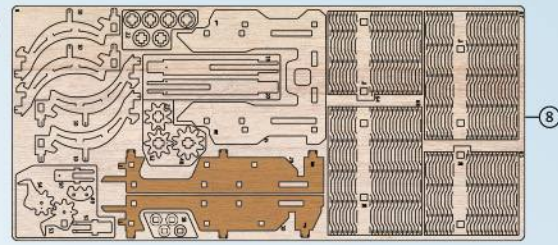

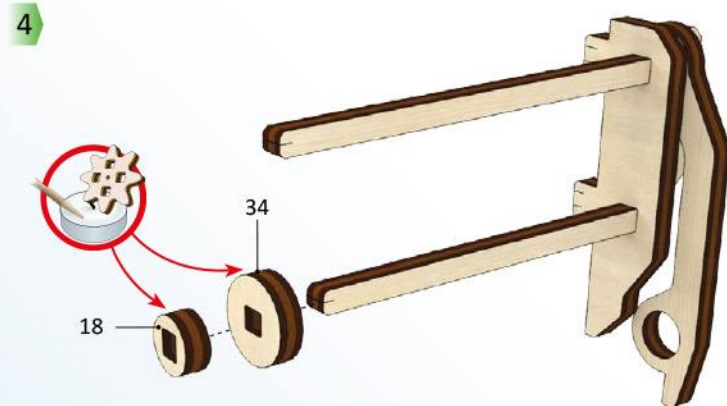
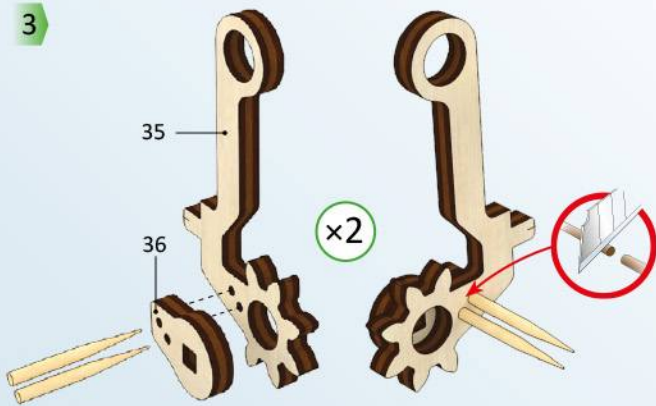
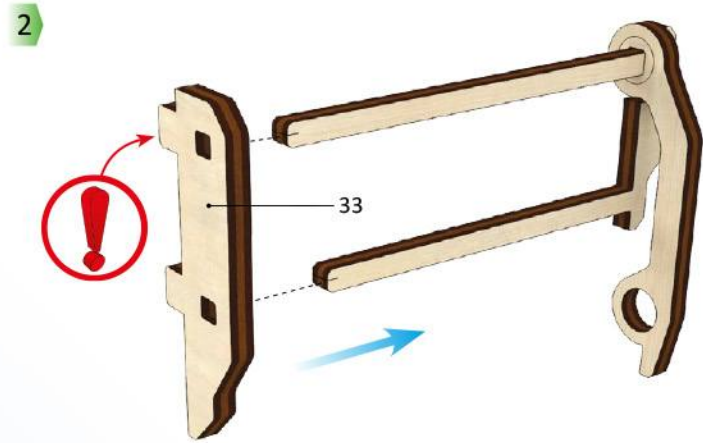
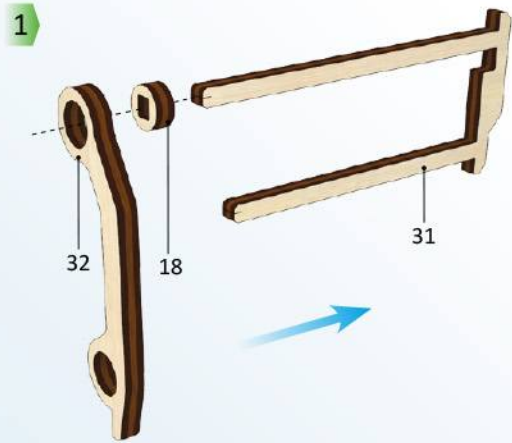
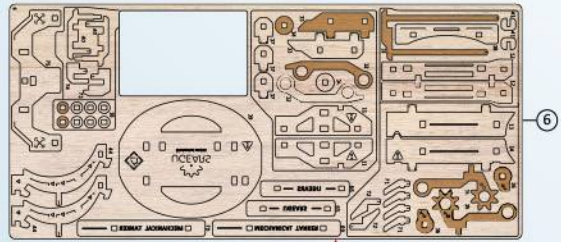

5

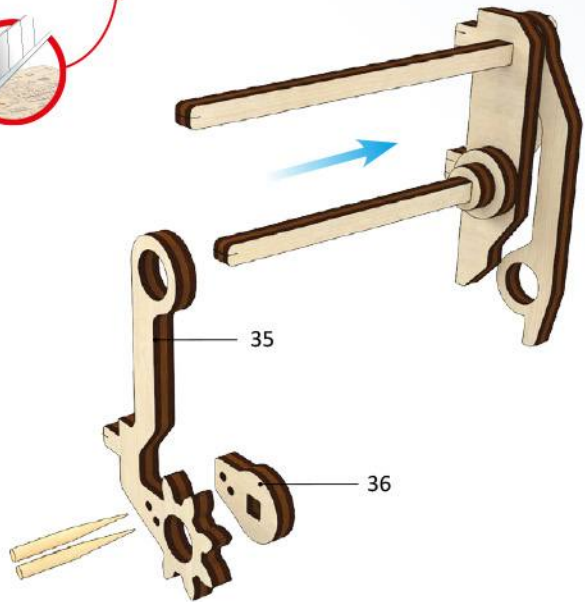
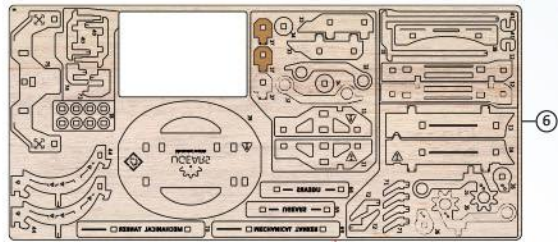

6

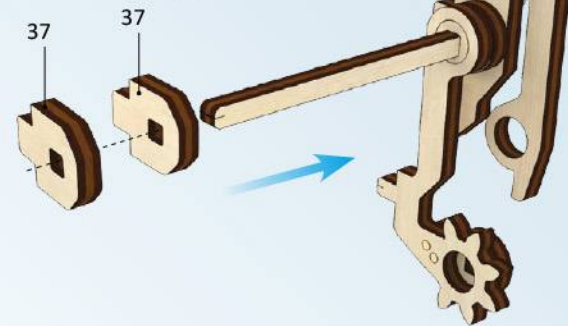
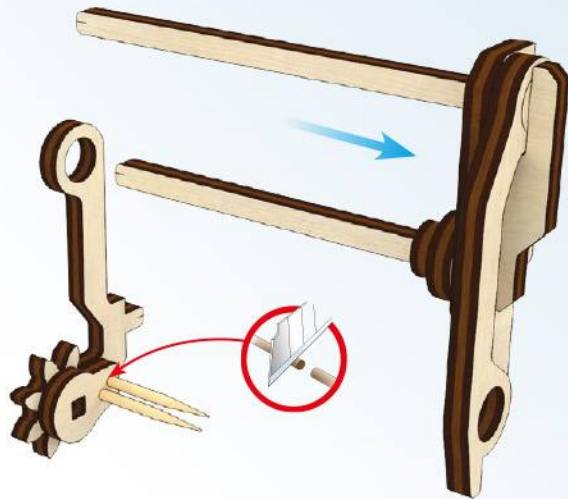

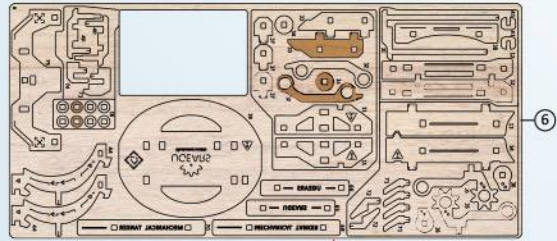

7

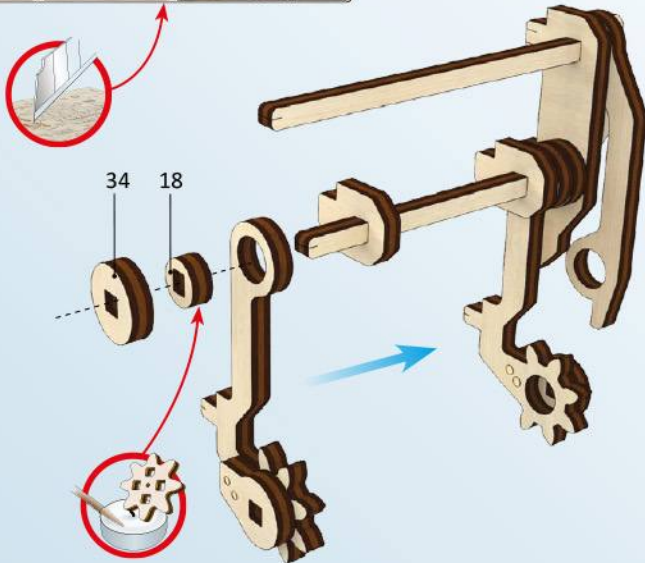

8

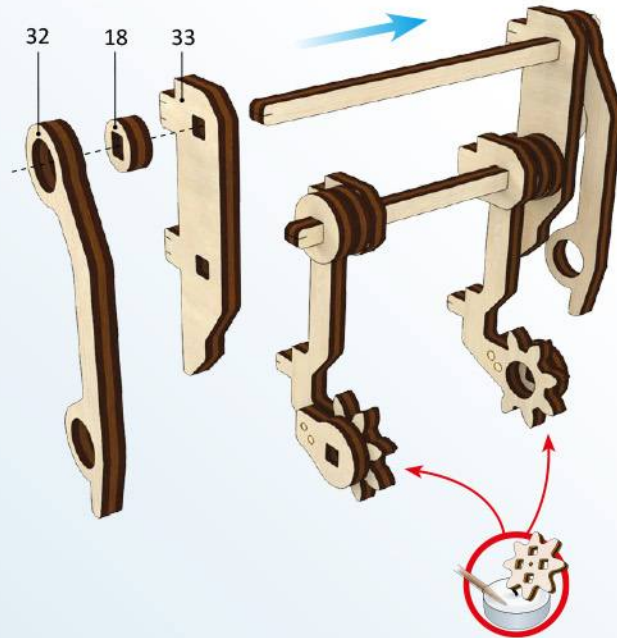

9

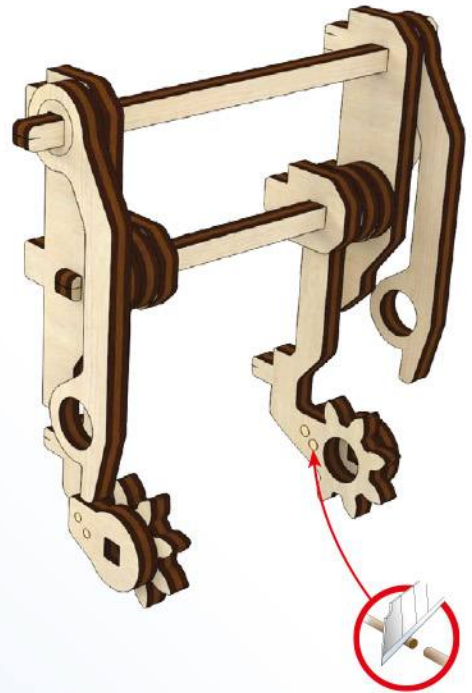

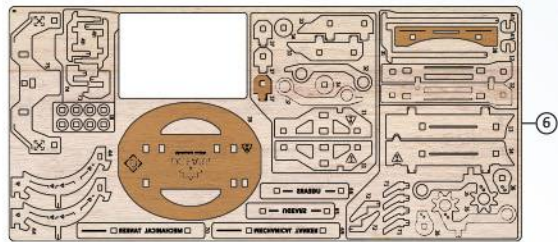

1

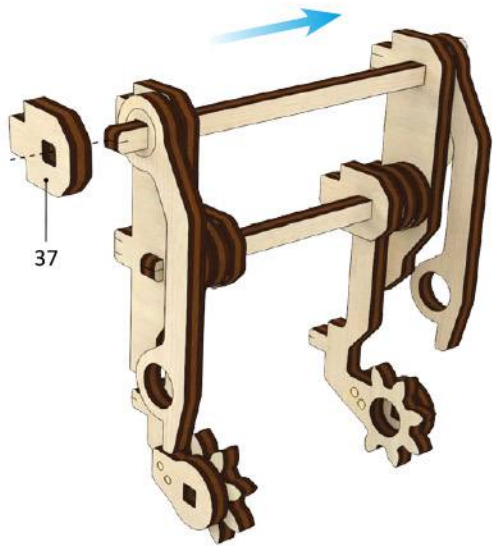

2

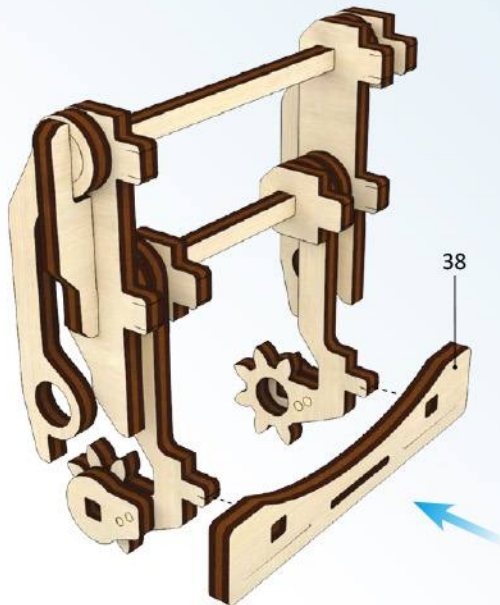

3

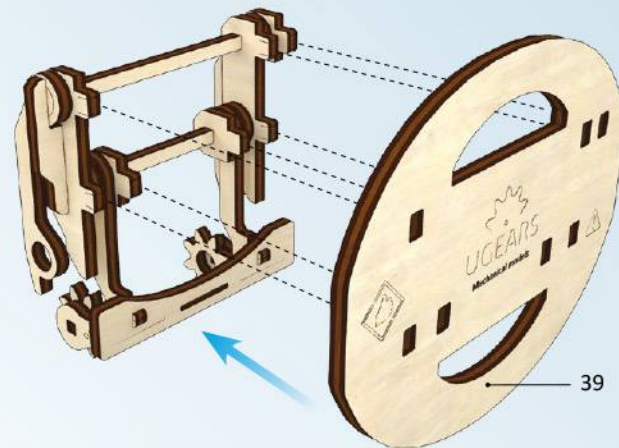

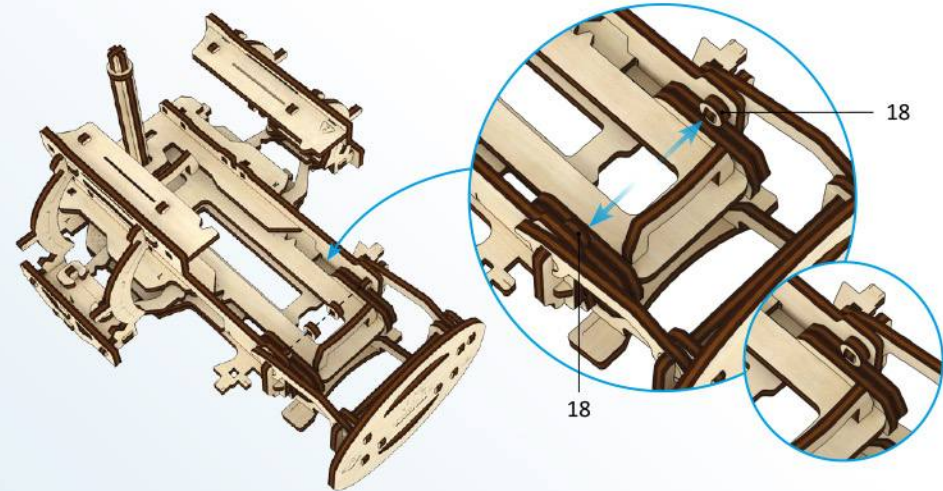
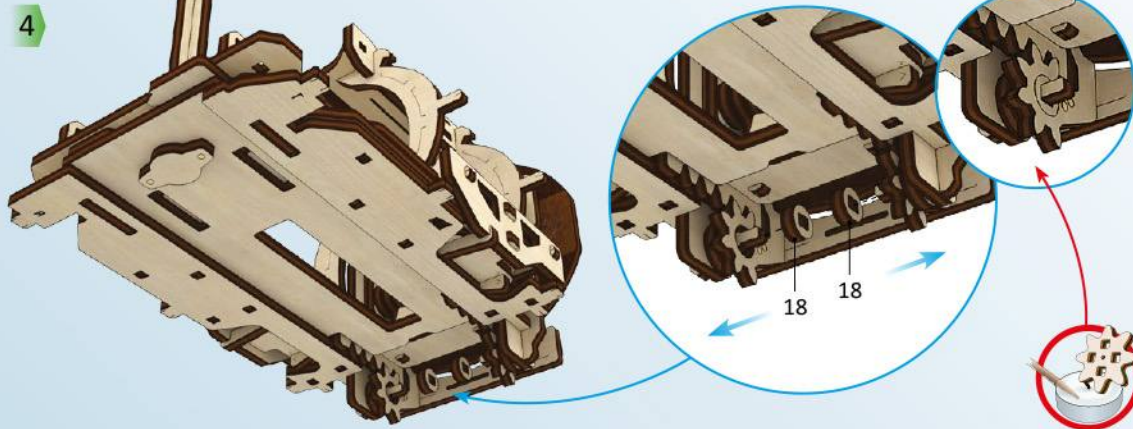
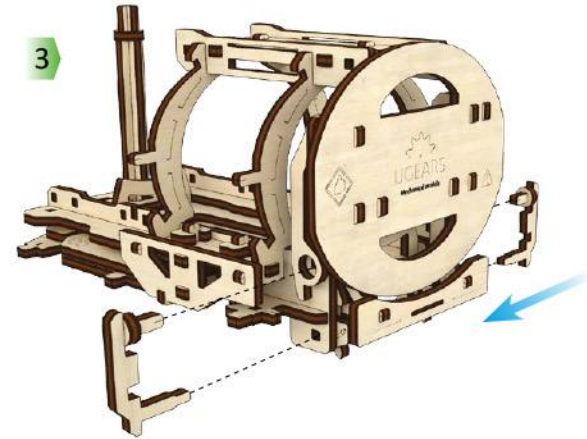
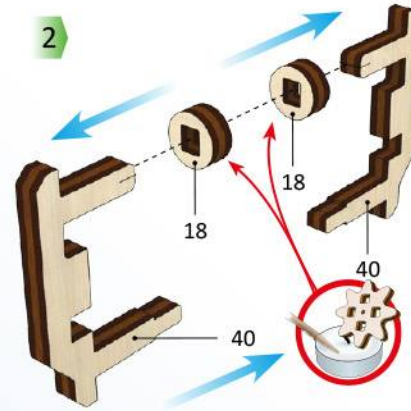
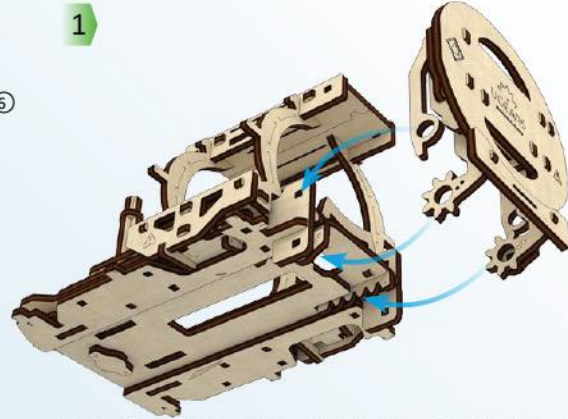
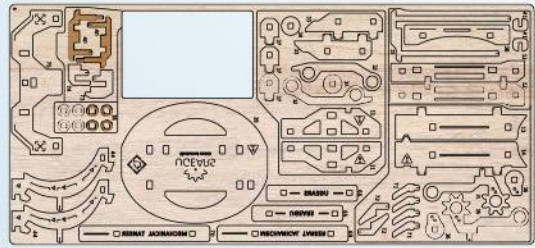

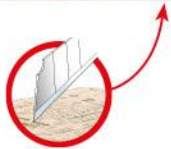
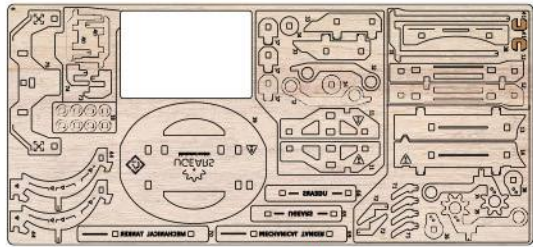

1

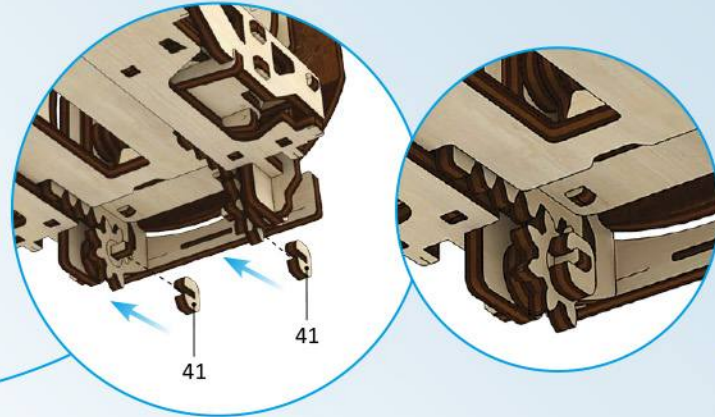
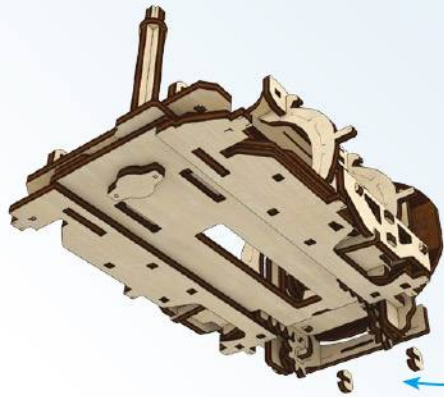

2

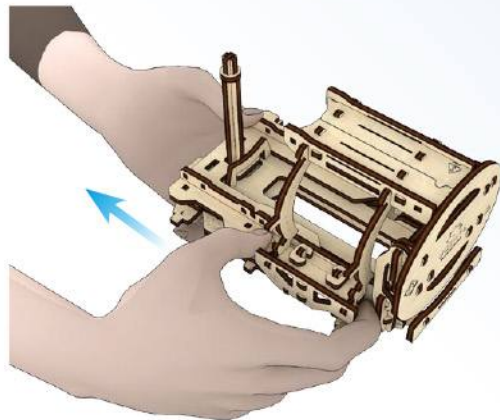

3

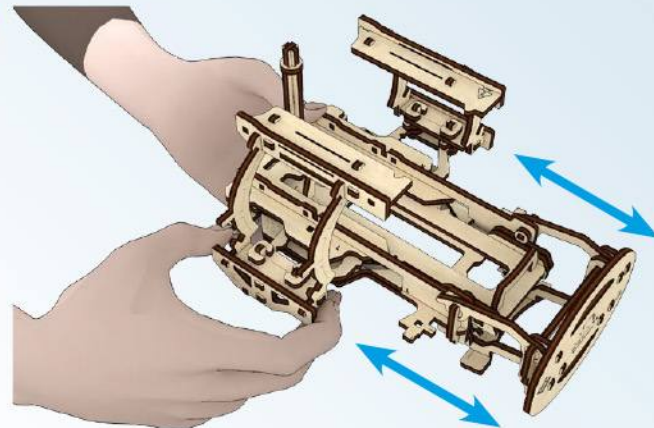

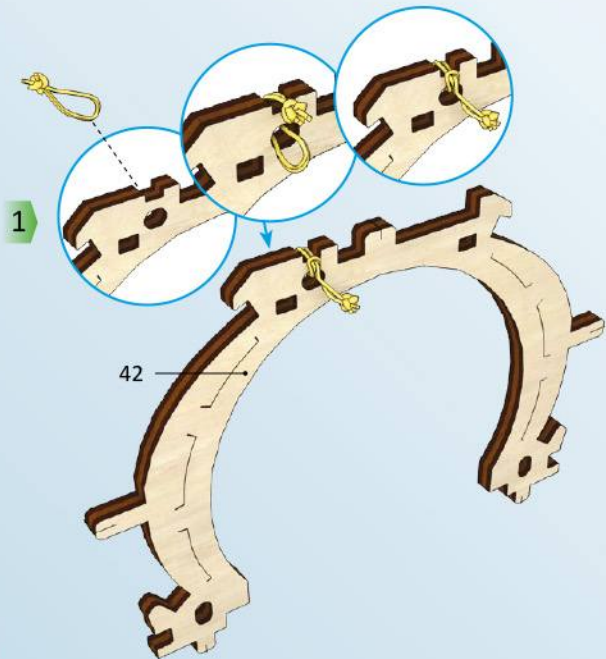
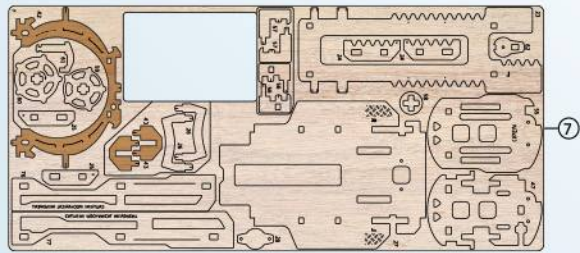

2

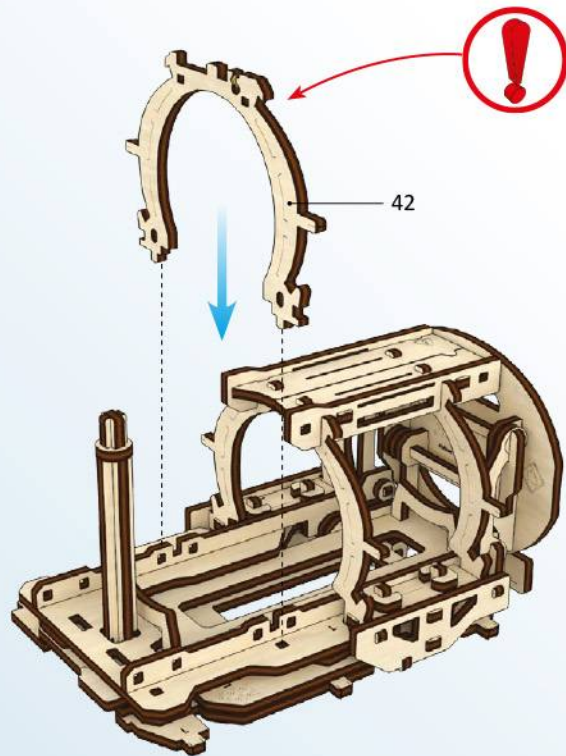

3

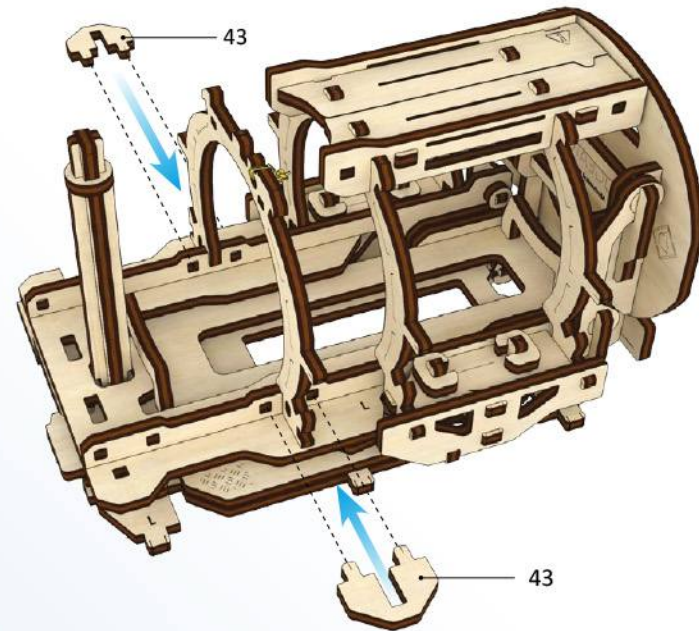

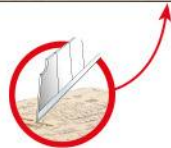
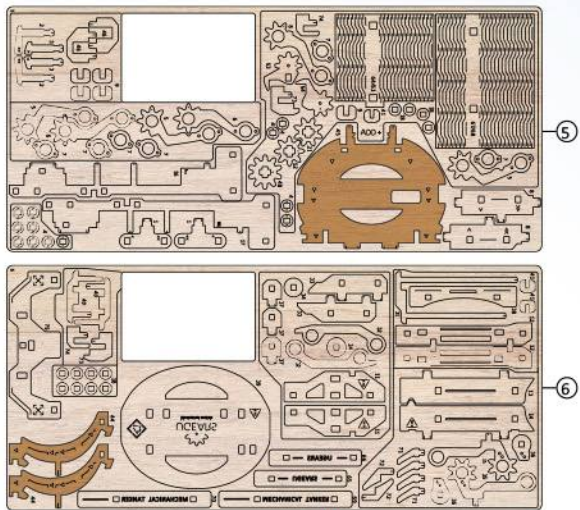

1

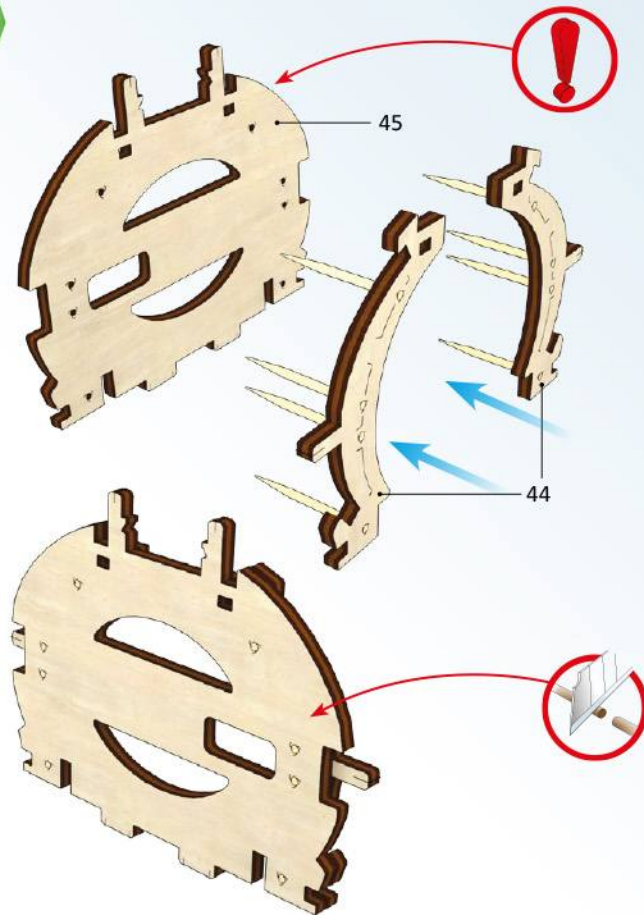

2

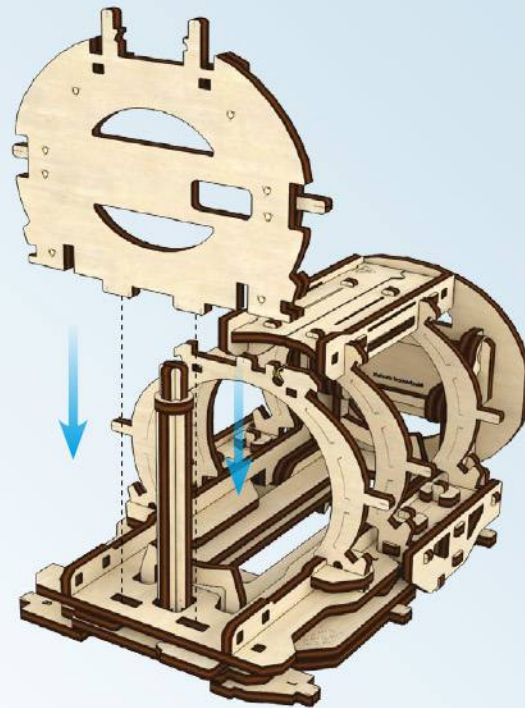

Mechanical models

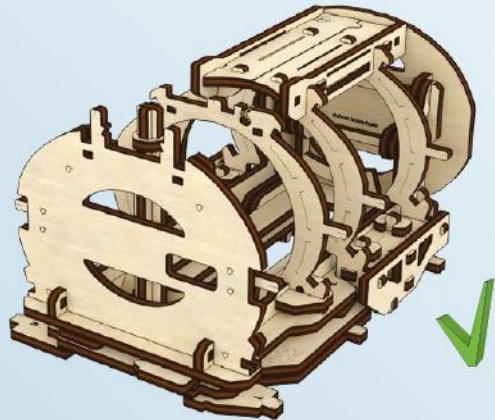
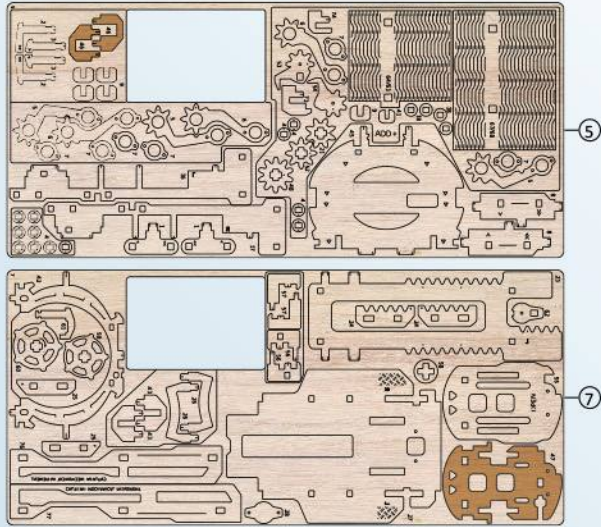

1

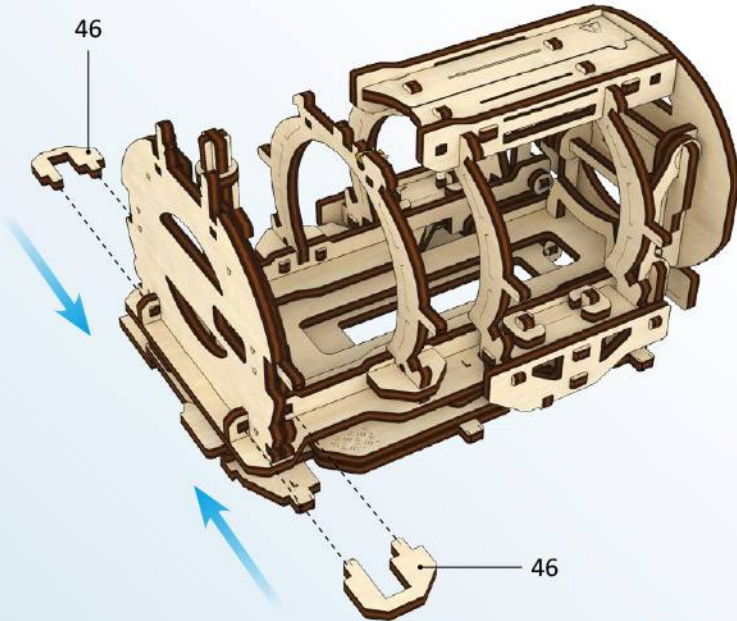

2

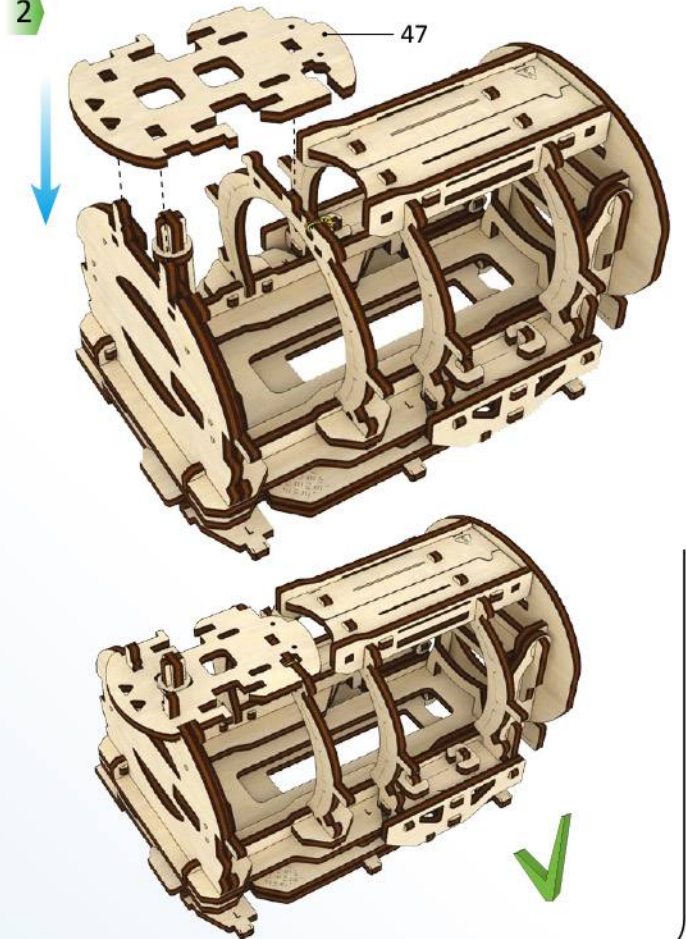

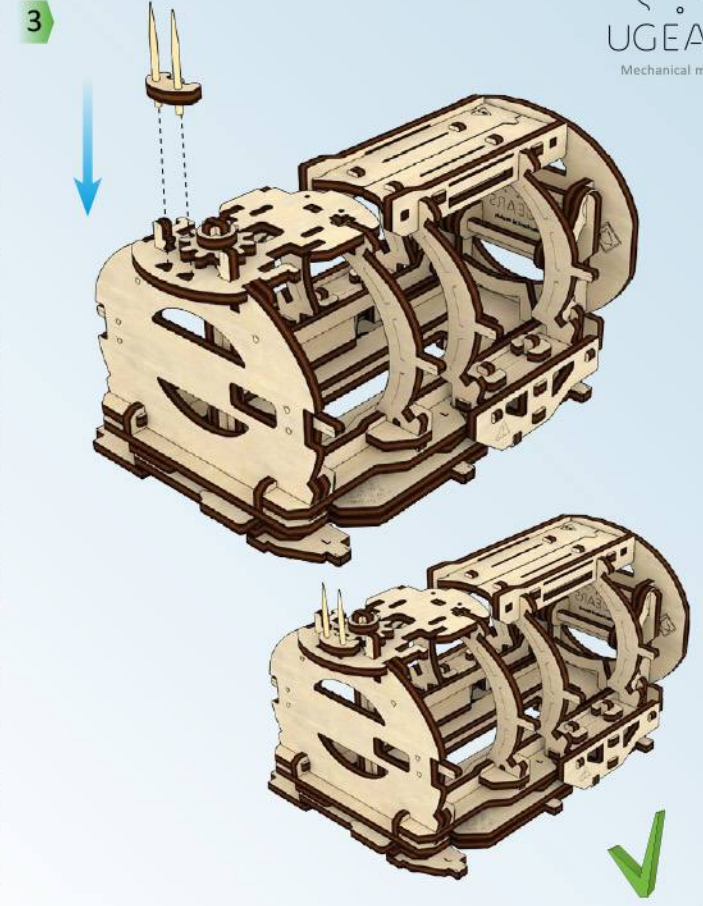
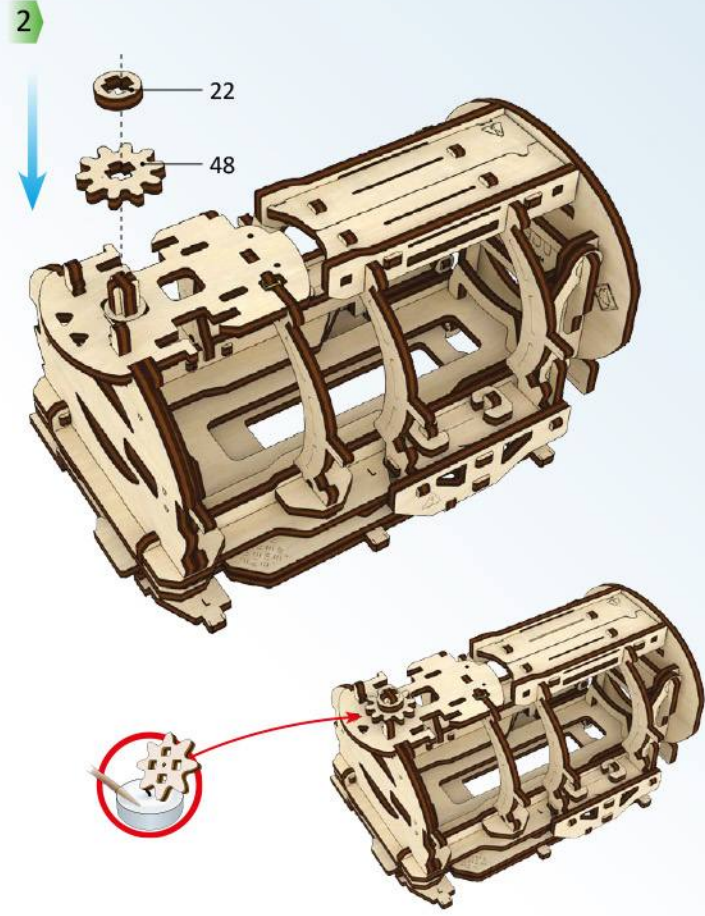
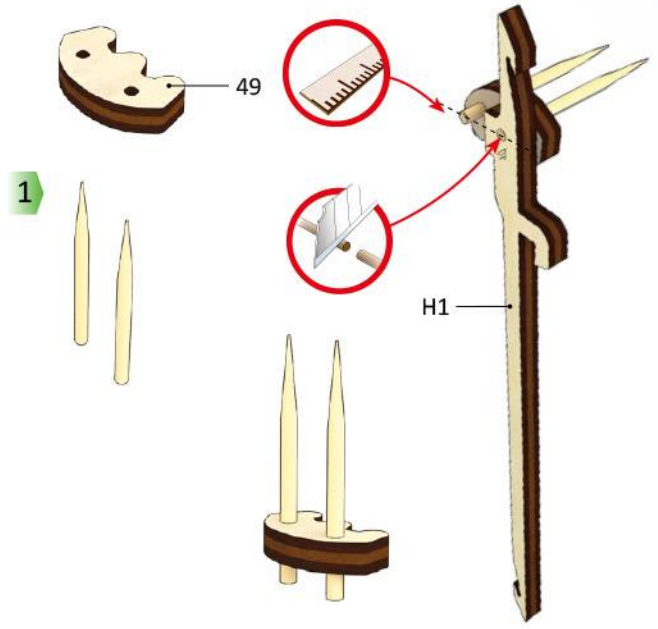
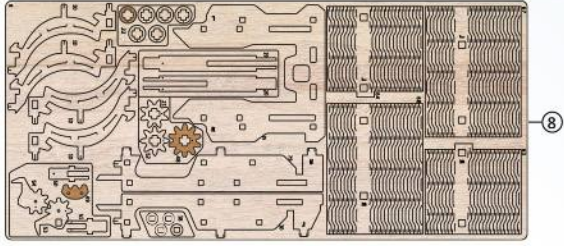

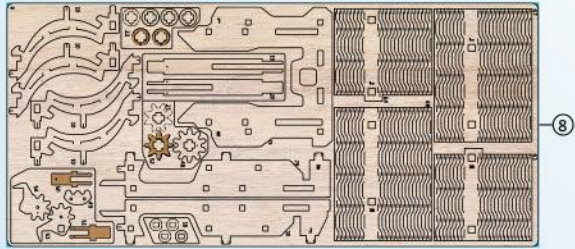

1

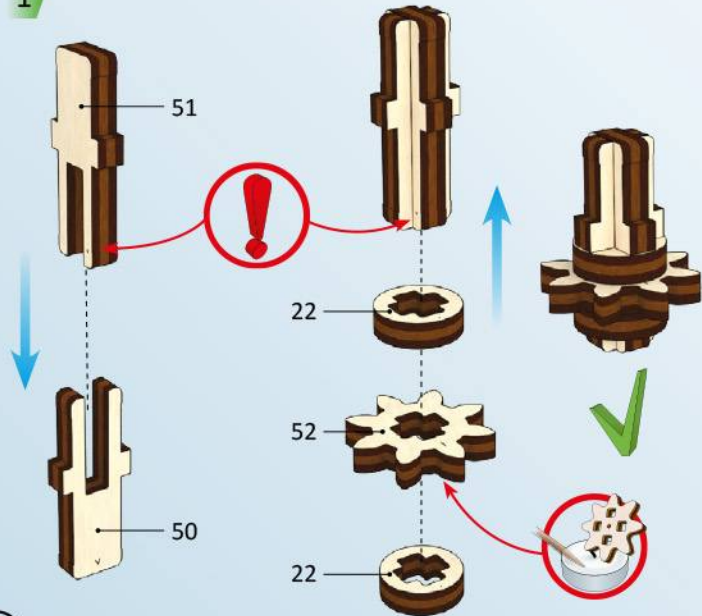

22

2

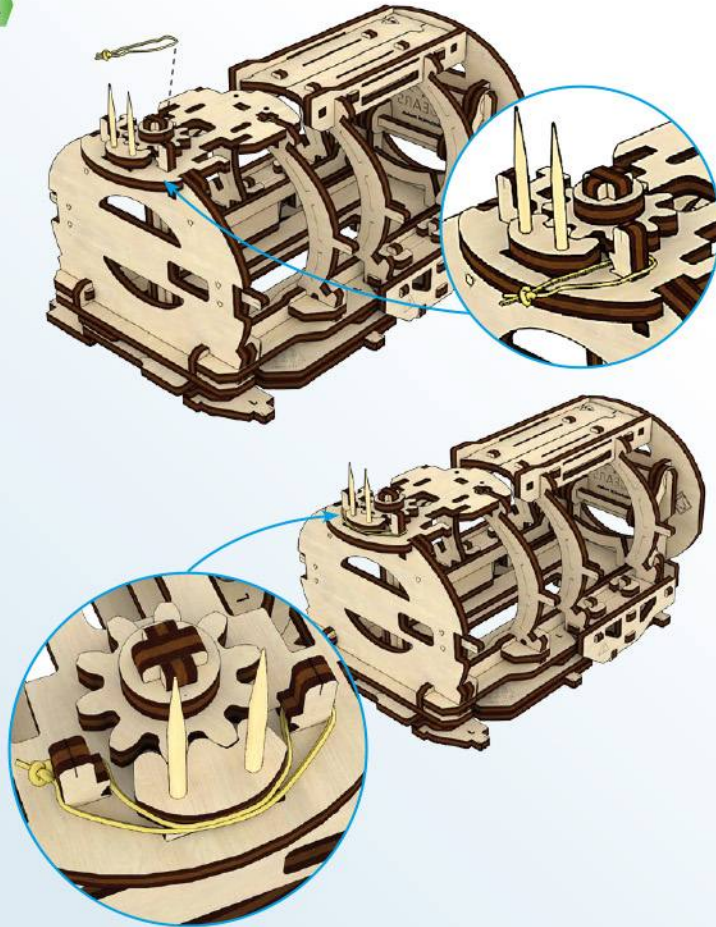

3

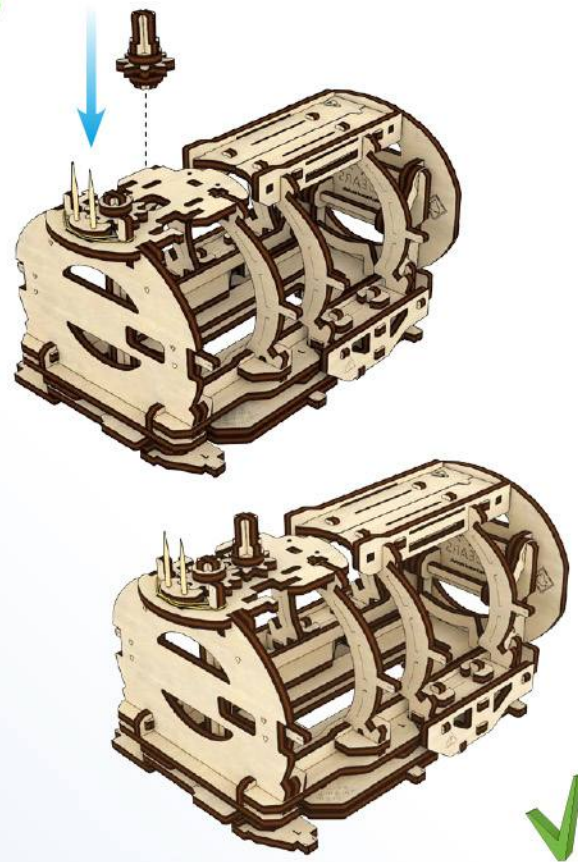

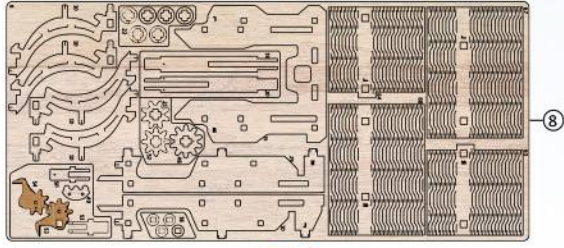

1

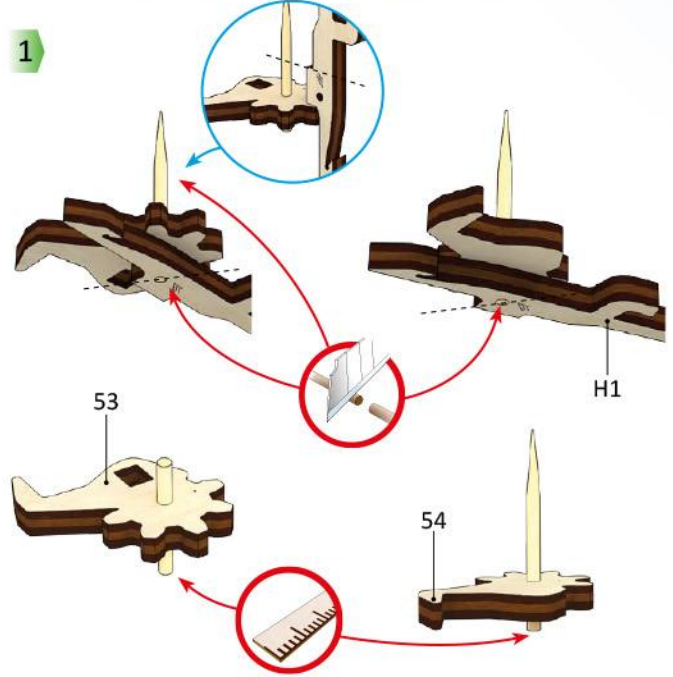

2

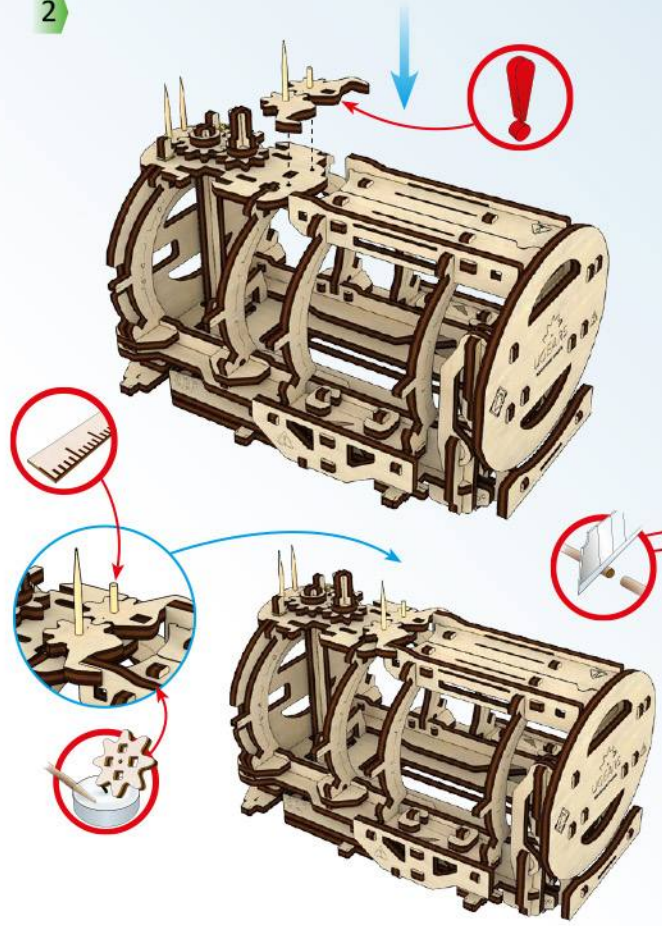

3

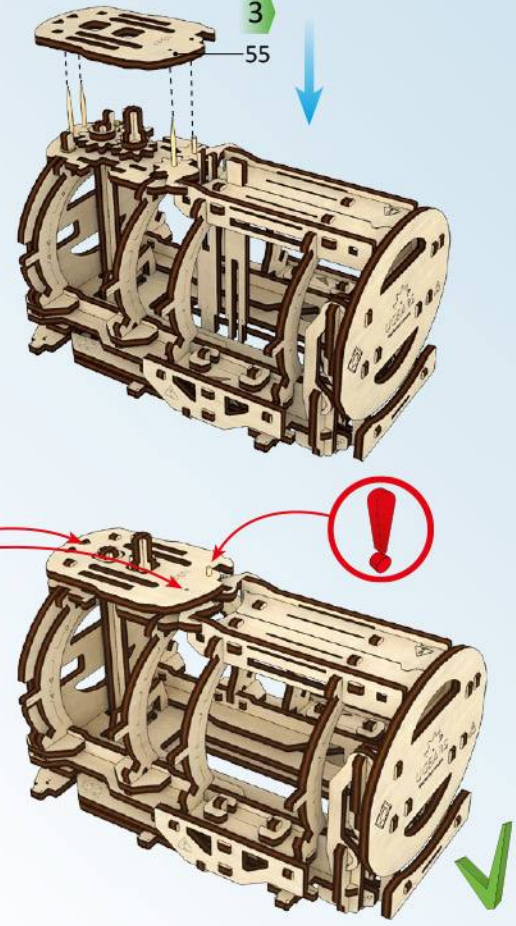

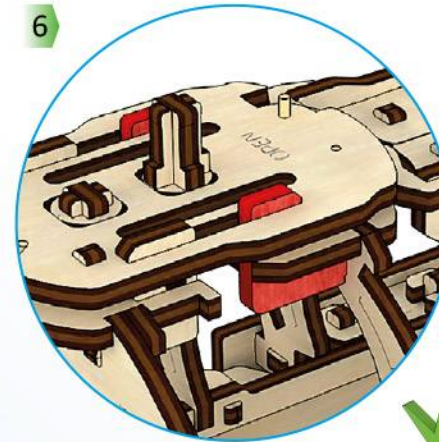
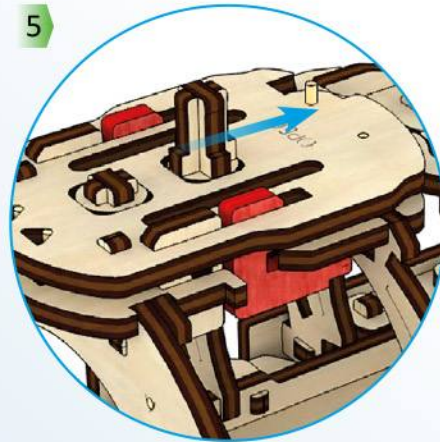
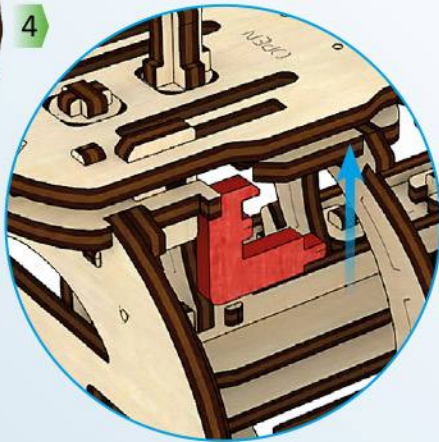
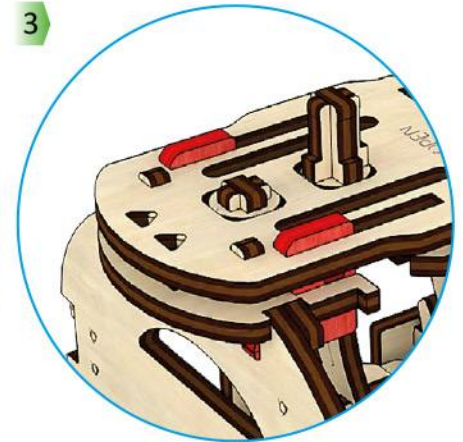
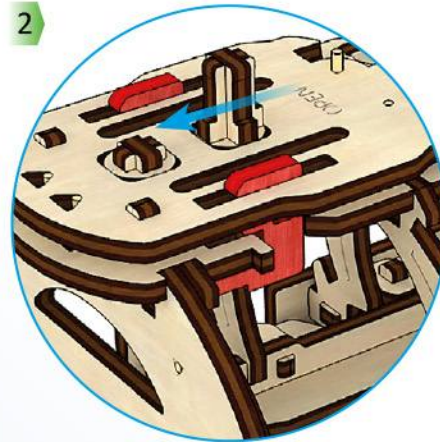
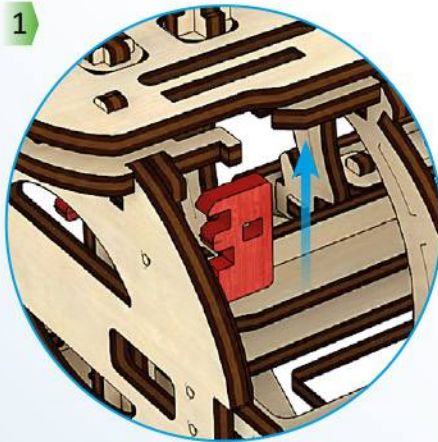
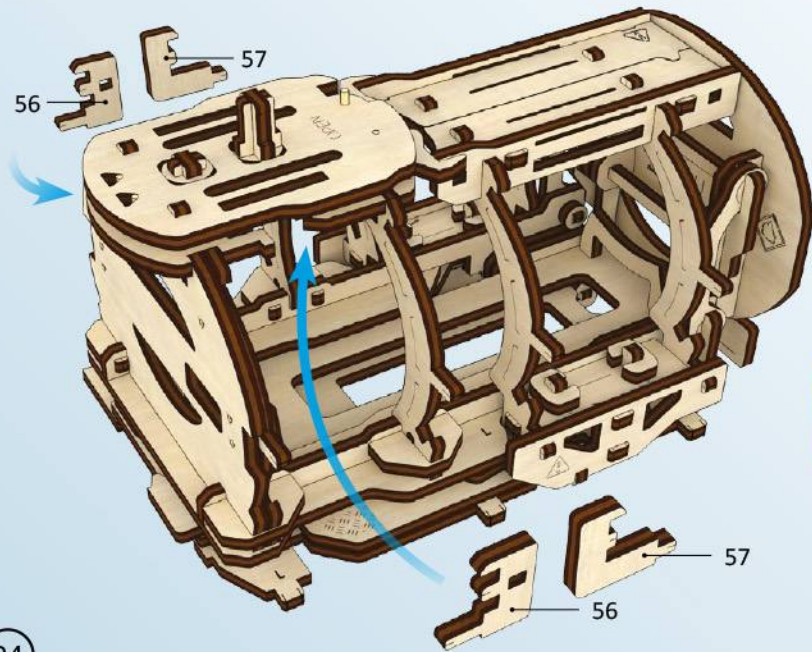
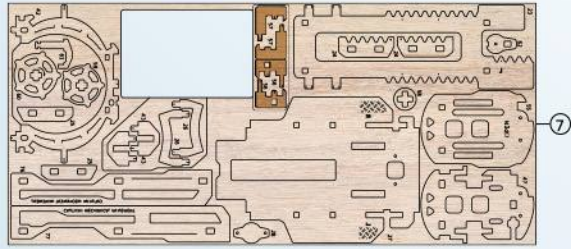

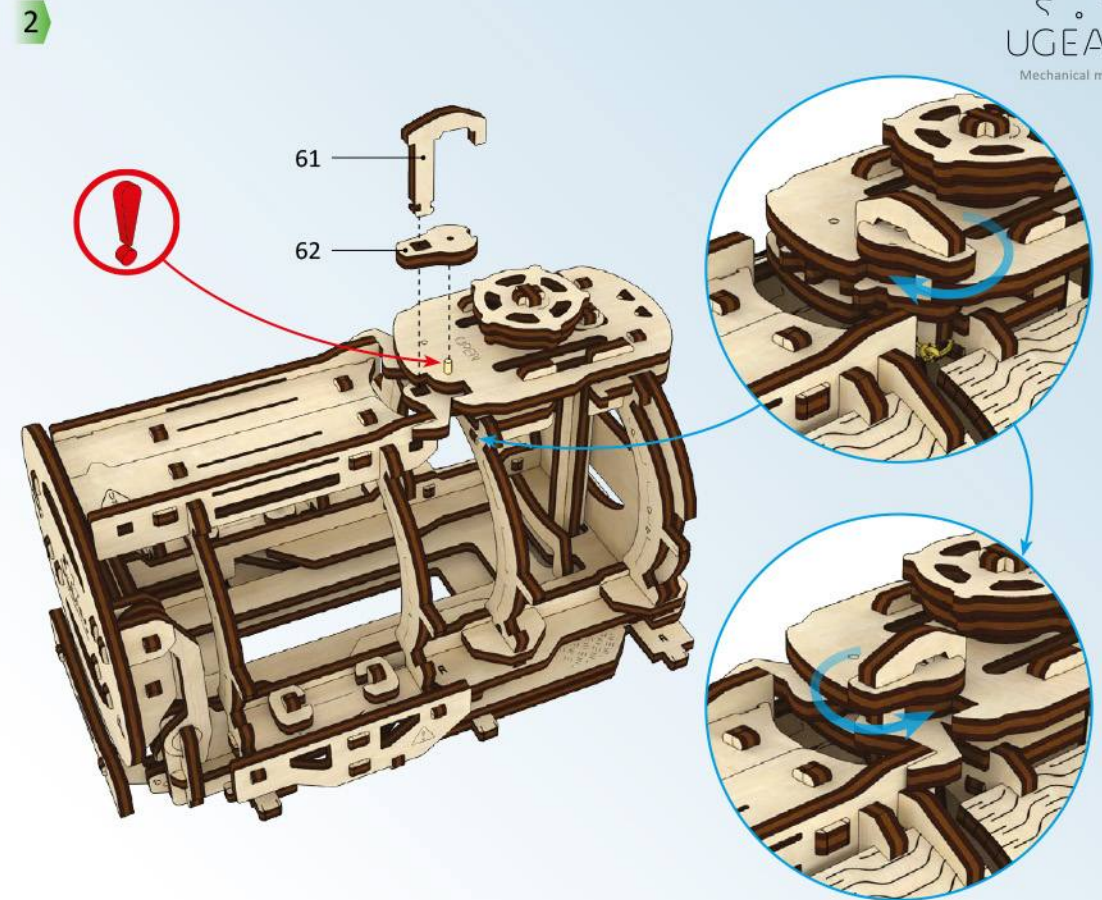
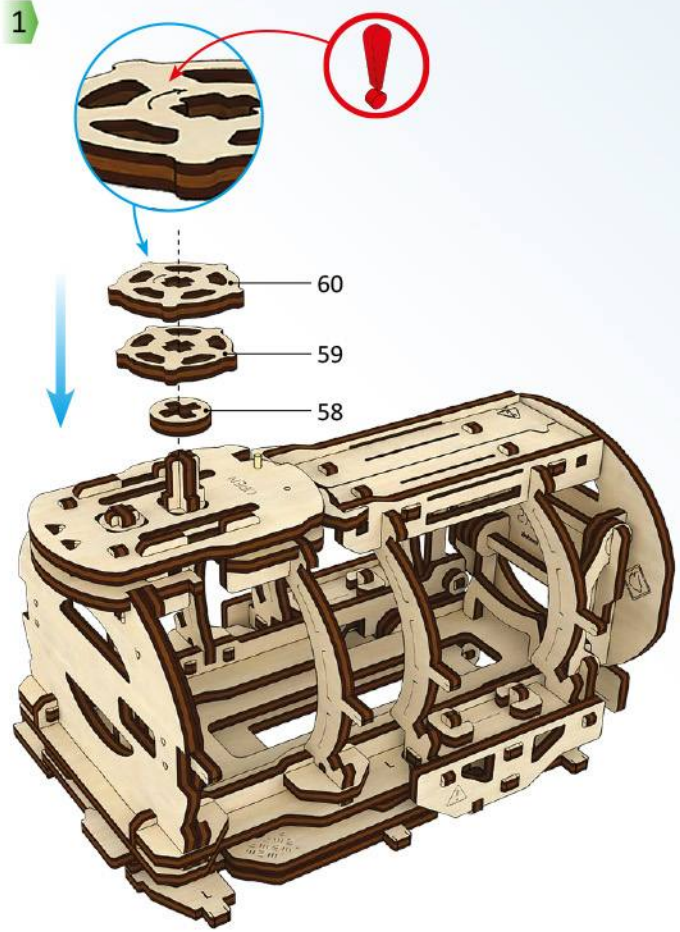
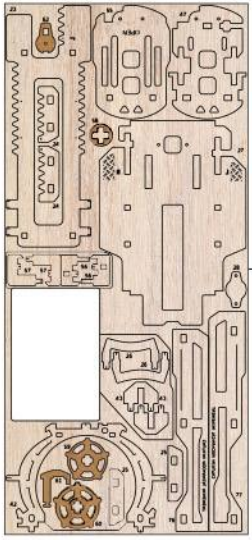

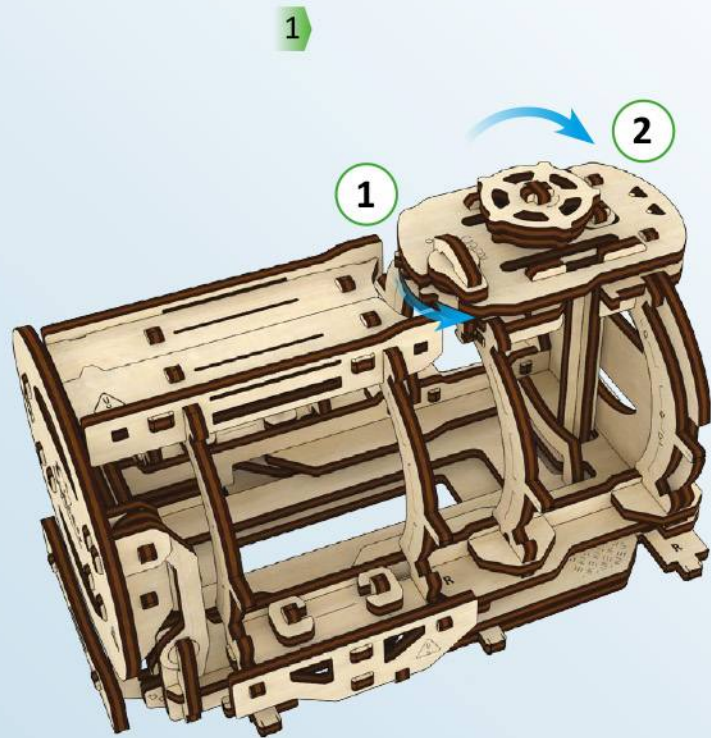

ENG Neatly turn it around. **UKR** Аккуратно поверніть. **DEU** Einmal vorsichtig umdrehen. **FRA** Tournez doucement. **POL** Starannie obróćić dookoła. **SPA** Cuidadosamente déle la vuelta. **ITA** Girare con la dovuta calma. **RUS** Аккуратно поверните. **JAP** スムーズに回らないといけません。 **KOR** 부드럽게 돌아가야 합니다. **CHI** 轻轻地旋转。

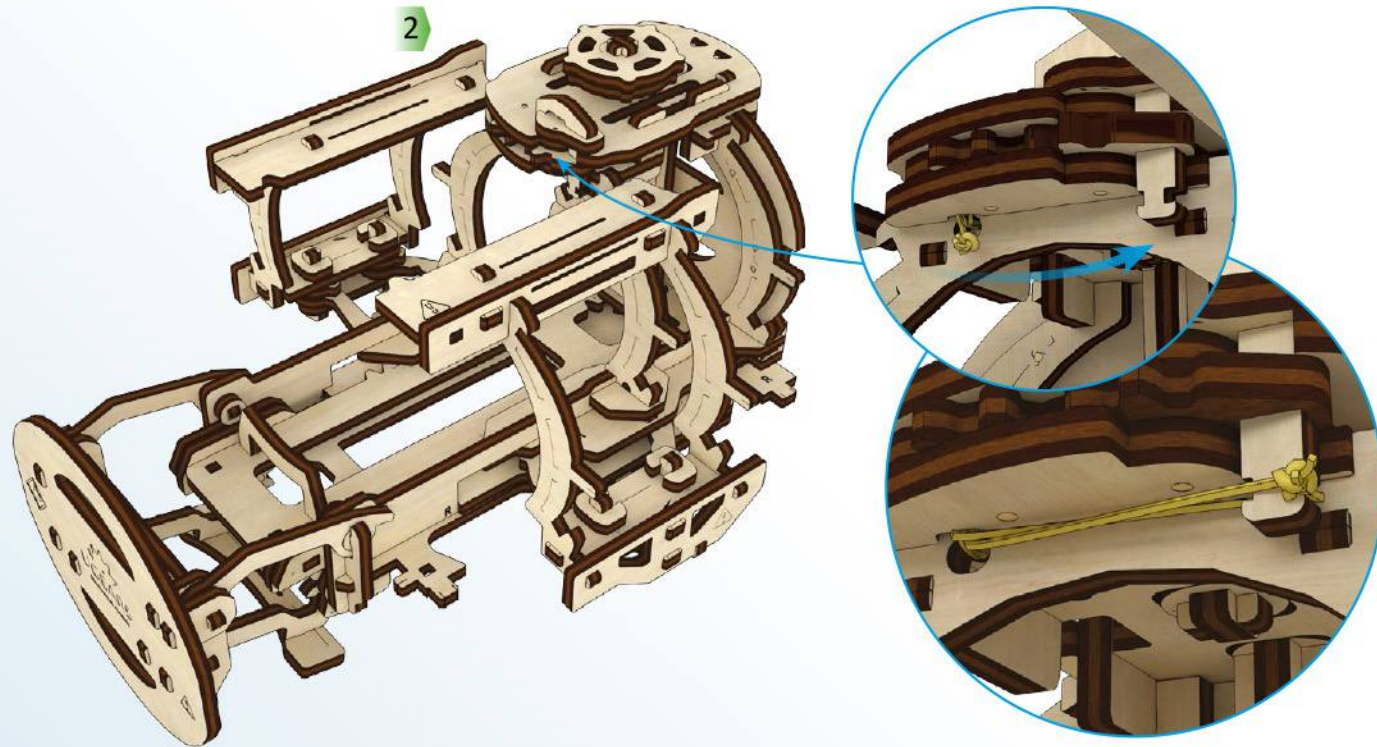

ENG The band should be tight. **UKR** Гумка повинна бути натягнута. **DEU** Das Gummi muss gespannt sein. **FRA** L'élastique doit être serré. **POL** Gumka powinna być naciągnięta. **SPA** El elástico debe ser ajustado. **ITA** L'elastico deve essere teso a sufficienza. **RUS** Резинка должна быть натянута. **JAP** ゴムバンドはしっかりと結びください。 **KOR** 고무밴드의 장력은 팽팽해야 합니다. **CHI** 橡皮筋必須拉紧。

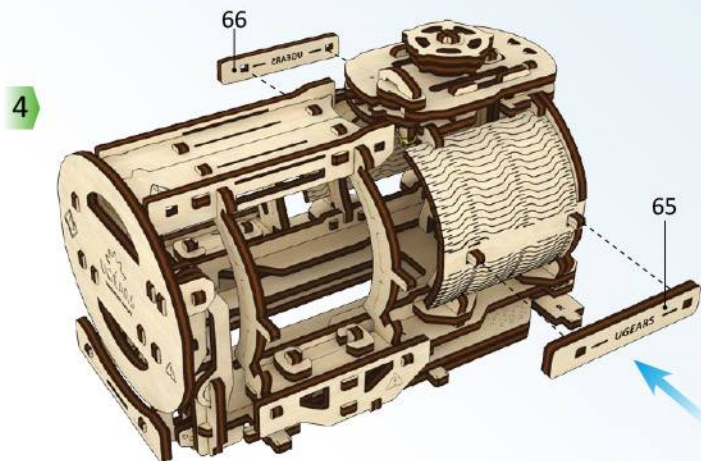
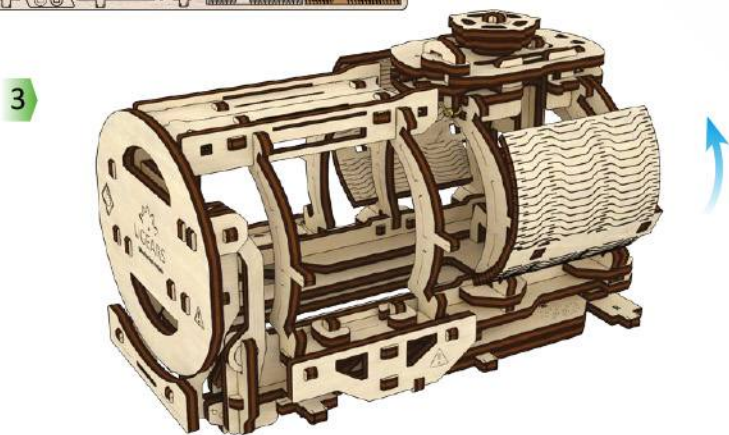
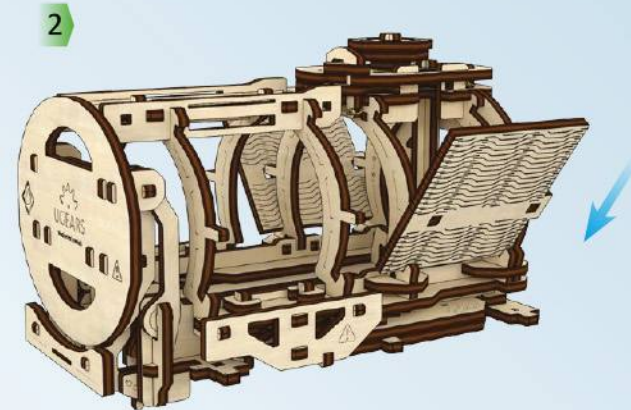
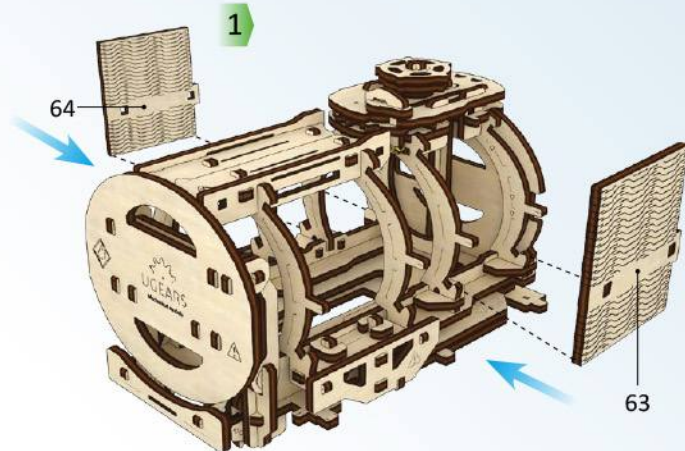
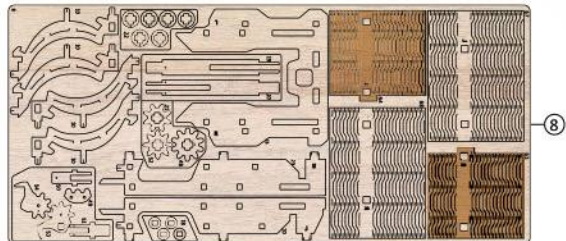
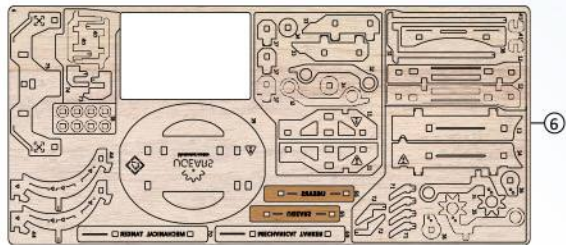

ENG Easily insert the part. **UKR** Легко вставте деталь. **DEU** Das Bauteil leicht einsetzen. **FRA** Insérez facilement la partie. **POL** Ostrożnie wymienić część. **SPA** Introduzca suavemente el detalle. **ITA** Inserire il complemento aggiuntivo con facilità. **RUS** Легко установите деталь. **JAP** 部品を慎重に差し込んでください。 **KOR** 부품을 살짝 끼워주세요. **CHI** 轻松地插入零件。

ENG Caution! Do not bend strongly! **UKR** Обережно! Сильно не згинати! **DEU** Vorsicht! Nicht zu stark verbiegen! **FRA** Attention! Ne pas plier avec force! **POL** Uwaga! Nie zginać mocno! **SPA** ¡Precaución! No doblar fuertemente! **ITA** Attenzione! Non piegare con forza! **RUS** Осторожно! Сильно не сгибать! **JAP** 注意! あまりにも強く折り曲げないでください。 **KOR** 주의! 너무 강하게 구부리지 마세요. **CHI** 注意! 不要过度用力弯曲!

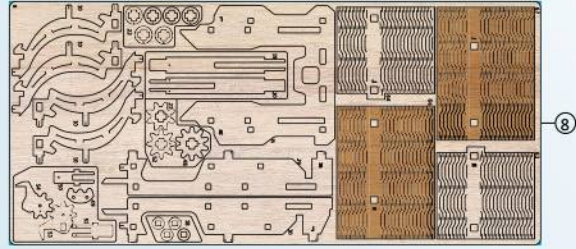

2

1

68

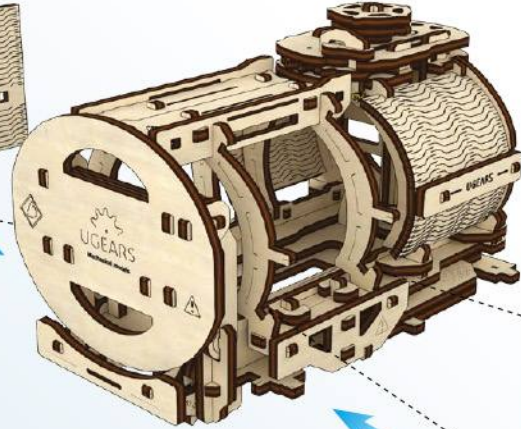
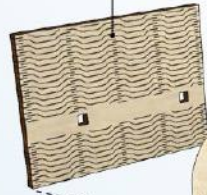

67

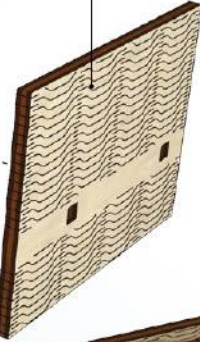

3

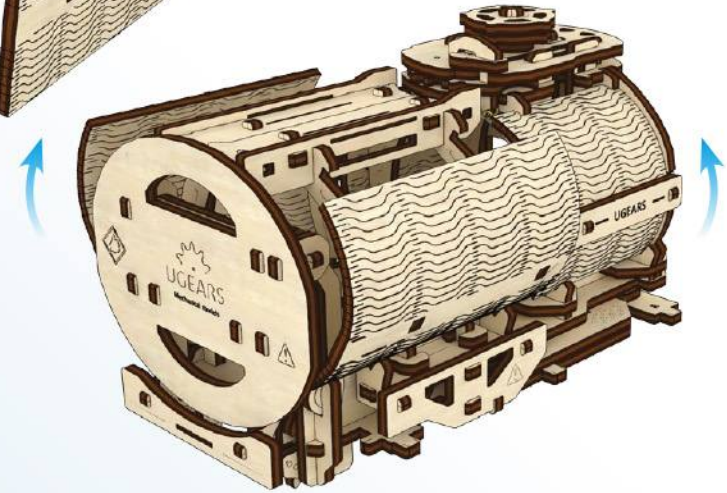
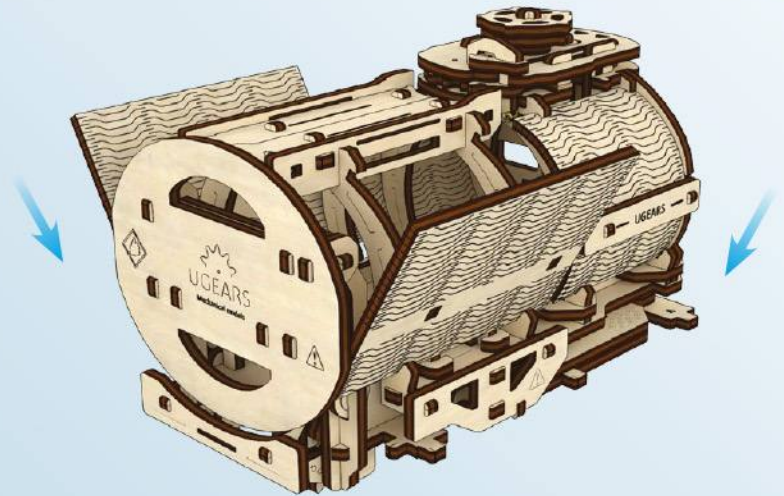

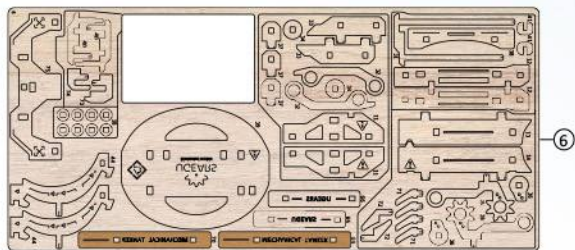

1

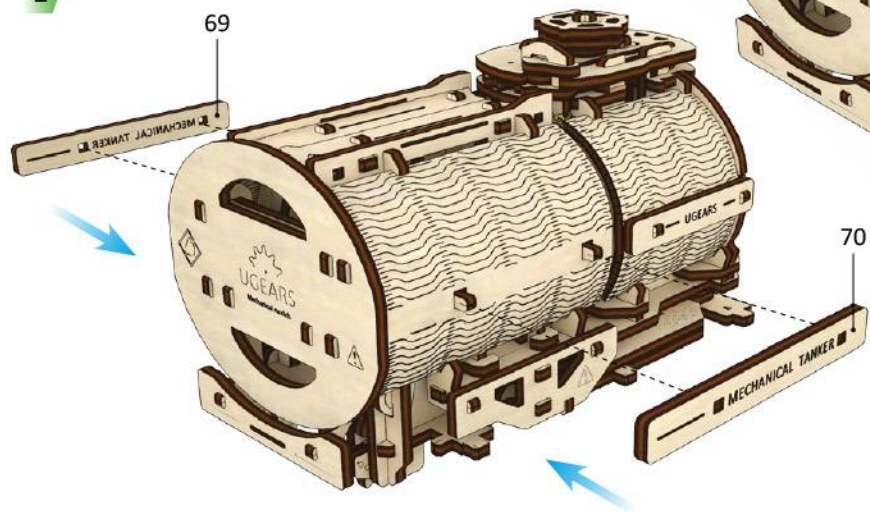

2

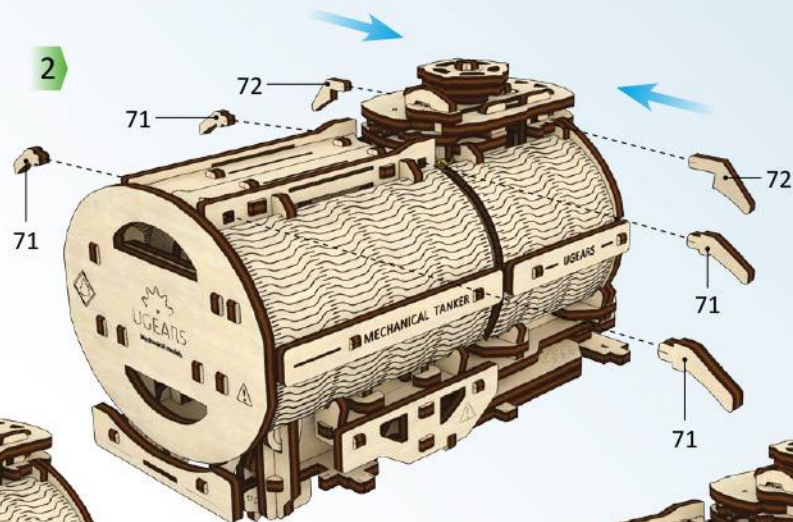

3

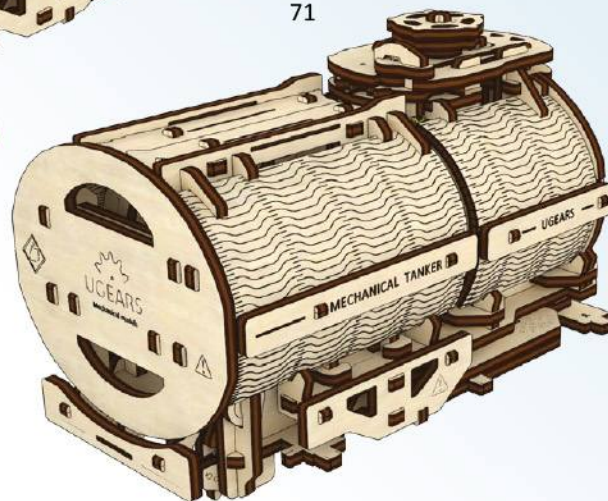

ENG The part can be replaced with an additional one from the set or alternative details may be cut out of the paper. Look page 66. **UKR** Деталь можна замінити на запасну з набору або вирізати альтернативні паперові деталі. Дивіться с. 66. **DEU** Das Bauteil kann durch eines aus den Ersatzteilen ersetzt werden oder aus dem Papier geschnitten werden. Siehe Seite 66. **FRA** La partie peut être remplacée par une autre de l'ensemble ou d'autres détails peuvent être découpés sur le papier. Regardez à la page 66. **POL** Część można wymienić na zapasową z zestawu, lub wyciąć zastępczą z papieru. Patrz strona 66. **SPA** La pieza puede ser reemplazada con una otra adicional del conjunto, o los detalles alternativos pueden ser cortados del papel. La hoja a la página 66. **ITA** Si puo' sostituire il complemento del camion con un altro dal set si puo' anche tagliare un dettaglio alternativo dalla carta. Guarda pag. 66. **RUS** Деталь можно заменить на запасную из набора. Или вырезать альтернативные бумажные детали. Смотрите с. 66. **JAP** 該当部品はセットに含まれている予備部品や66ページのペーパーを切って代用も可能です。 **KOR** 해당 부품은 세트에 포함된 여유 부품이나 66페이지의 종이를 잘라 대체할 수 있습니다. **CHI** 该零部件可以用该套备件替换，或者可以剪出替代的纸造部件。参见第66页。

1



2



3

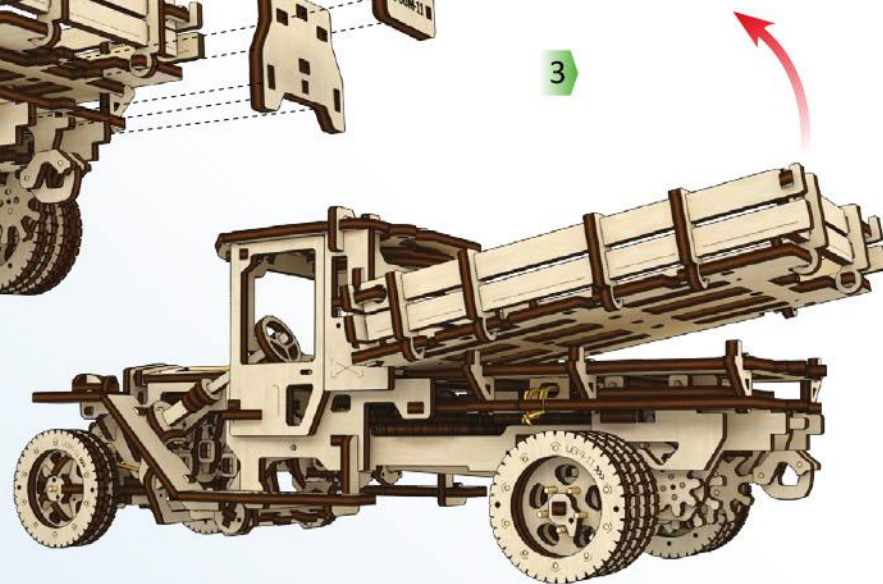

ENG Carefully remove the car body. UKR Аккуратно зніміть кузов. DEU Entfernen Sie vorsichtig den Pritschenaufbau. FRA Retirez délicatement la carrosserie du camion. POL Delikatnie zdjąć karoserię. SPA Extraiga cuidadosamente el cuerpo del coche. ITA Rimuovere il cassone con la dovuta calma. RUS Аккуратно демонтируйте кузов. JAP 注意しながら車の本体をお外してください。トレーラー KOR 적재함을 조심스럽게 분리해 주세요. CHI 小心地拆卸车体。

1

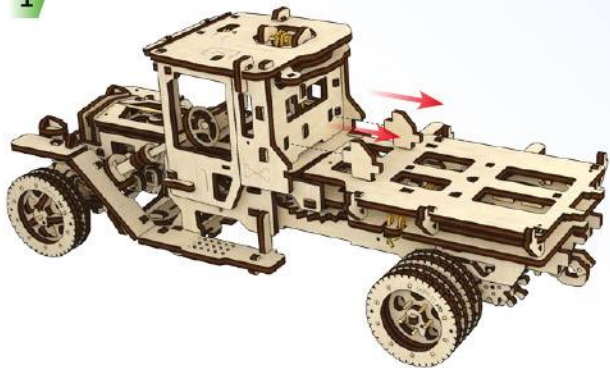

2

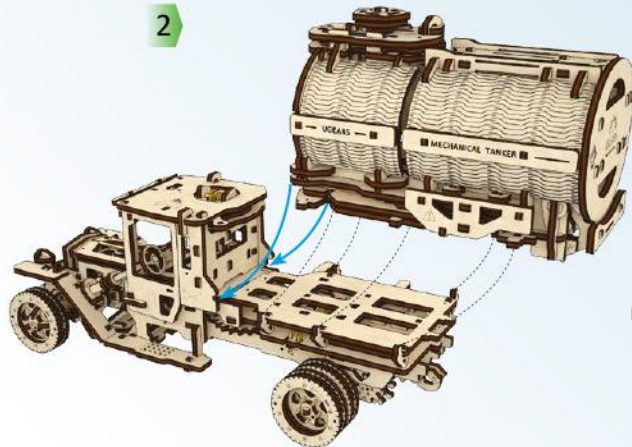

3



4

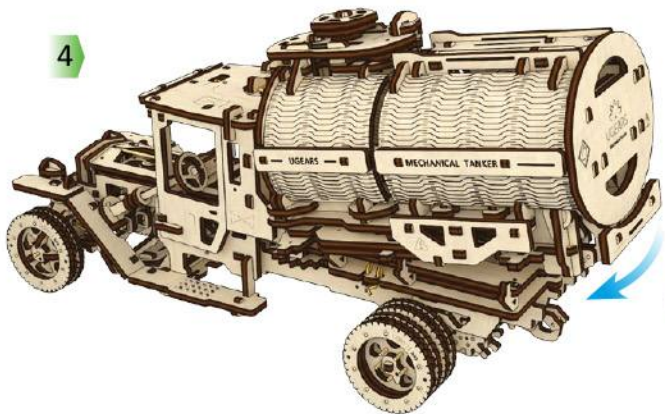

5

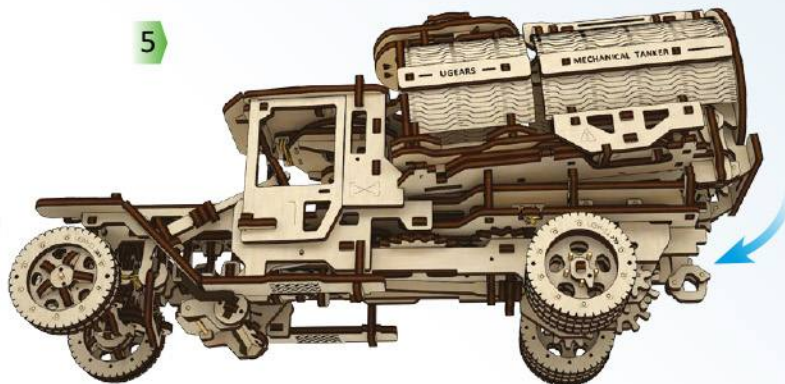

6

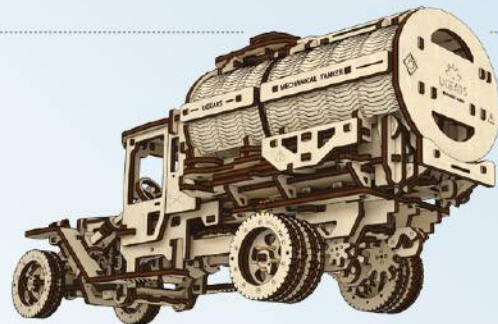

ENG Press the piece all the way in. **UKR** Притисніть деталь до упору. **DEU** Drücken Sie das Bauteil bis zum Anschlag ein. **FRA** Appuyez sur la pièce jusqu'en butée. **POL** Delikatnie dociskać część aż do momentu pocucia oporu. **SPA** Presione la pieza hasta que haga tope. **ITA** Premere il complemento aggiuntivo a fondo. **RUS** Прижмите деталь до упора. **JAP** しっかりと完全に押し込んでください。 **KOR** 누르고 밀어서 끼워 넣습니다. **CHI** 把消防梯压住到底。

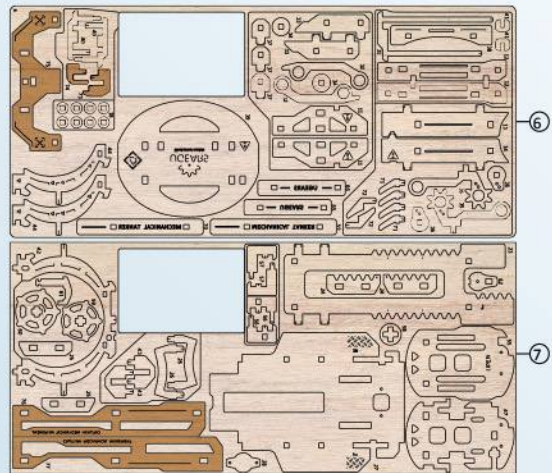

1

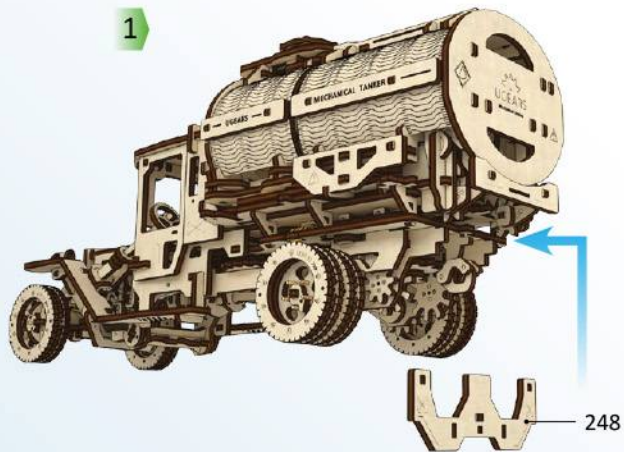

2

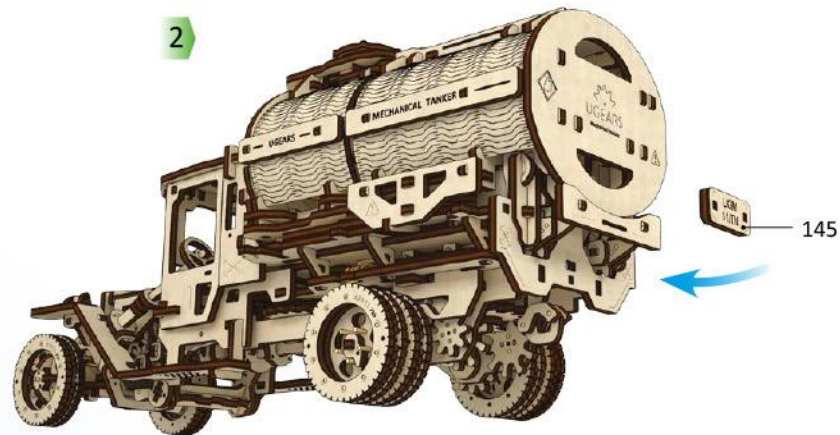

3

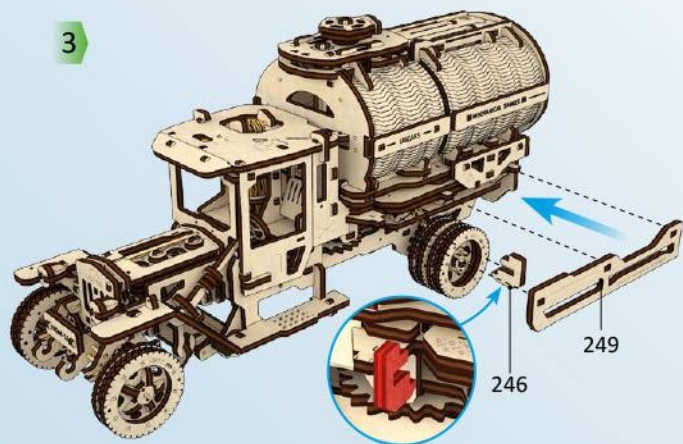

4

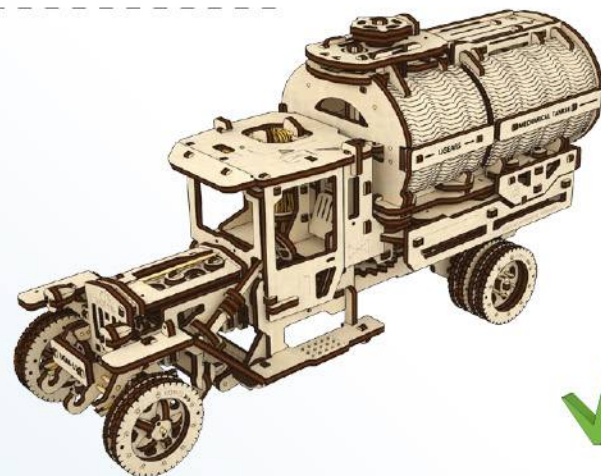
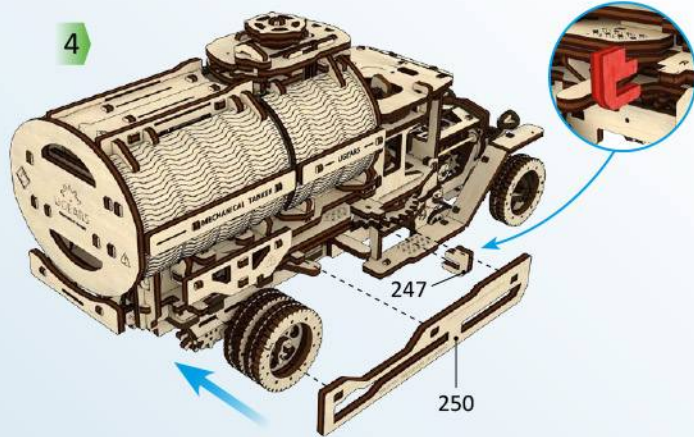

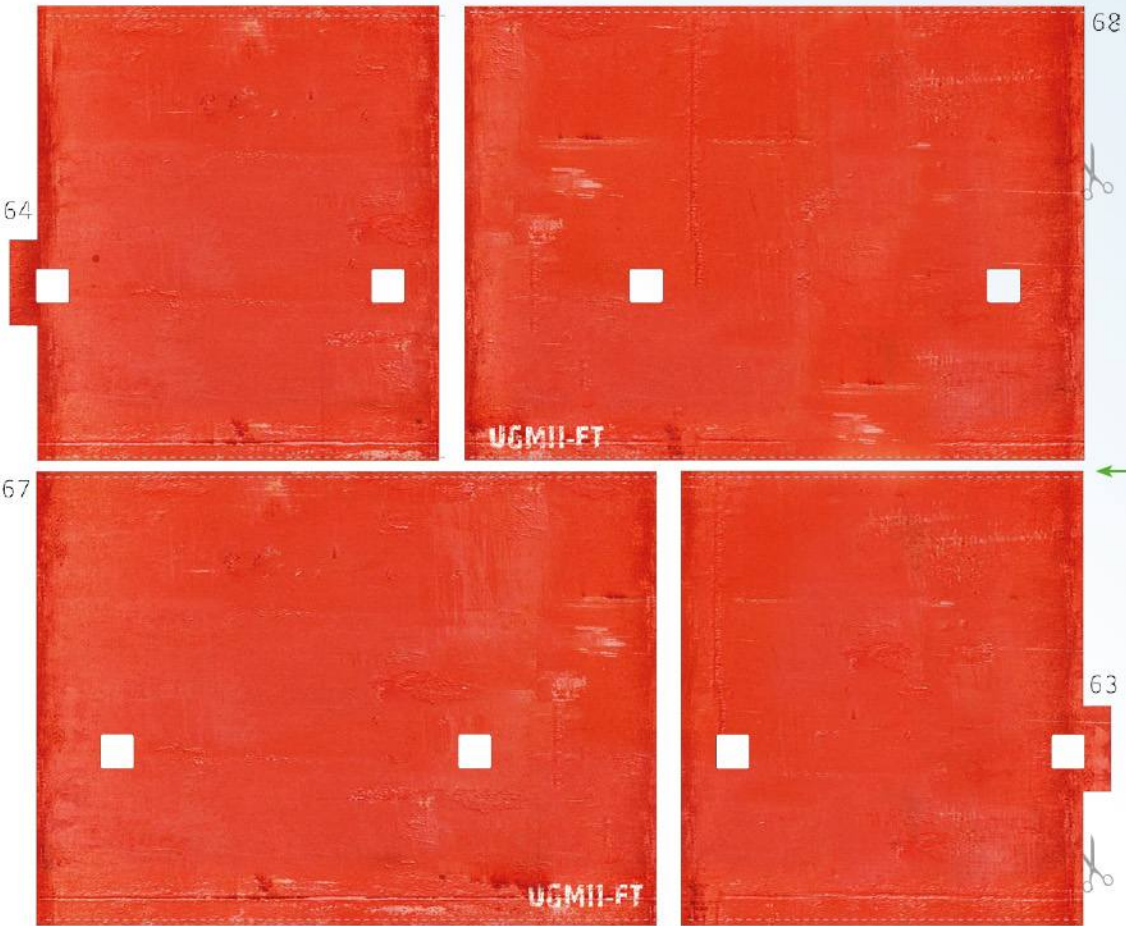
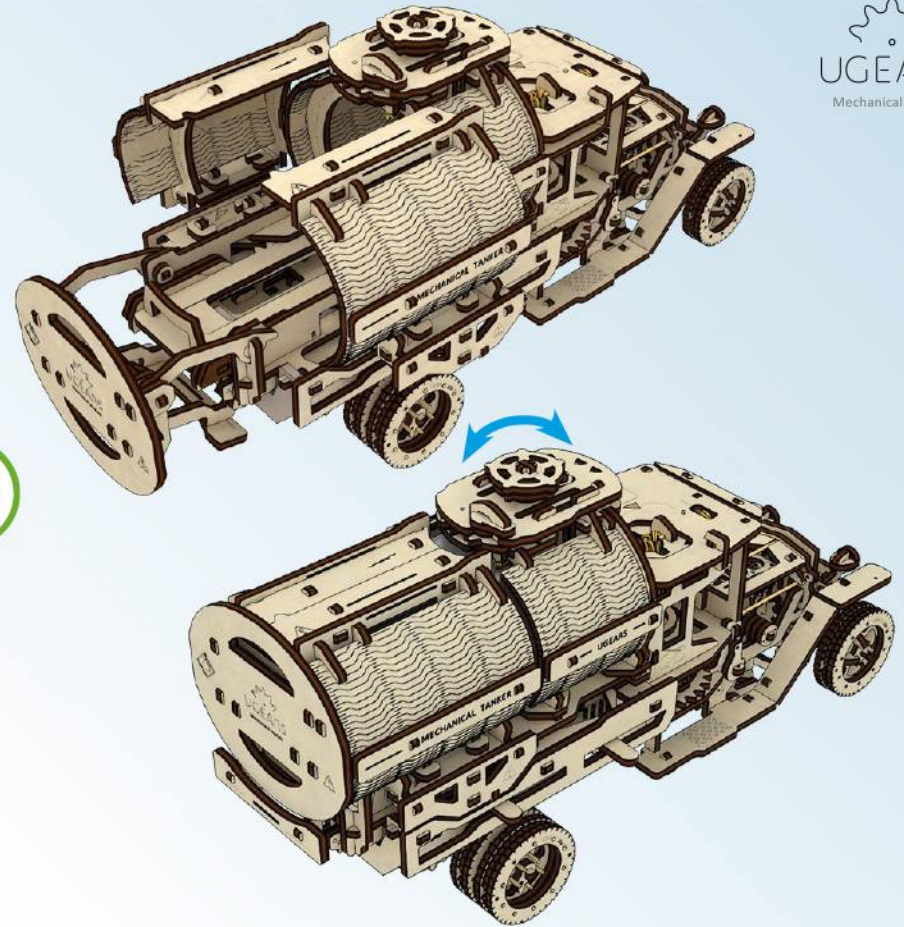

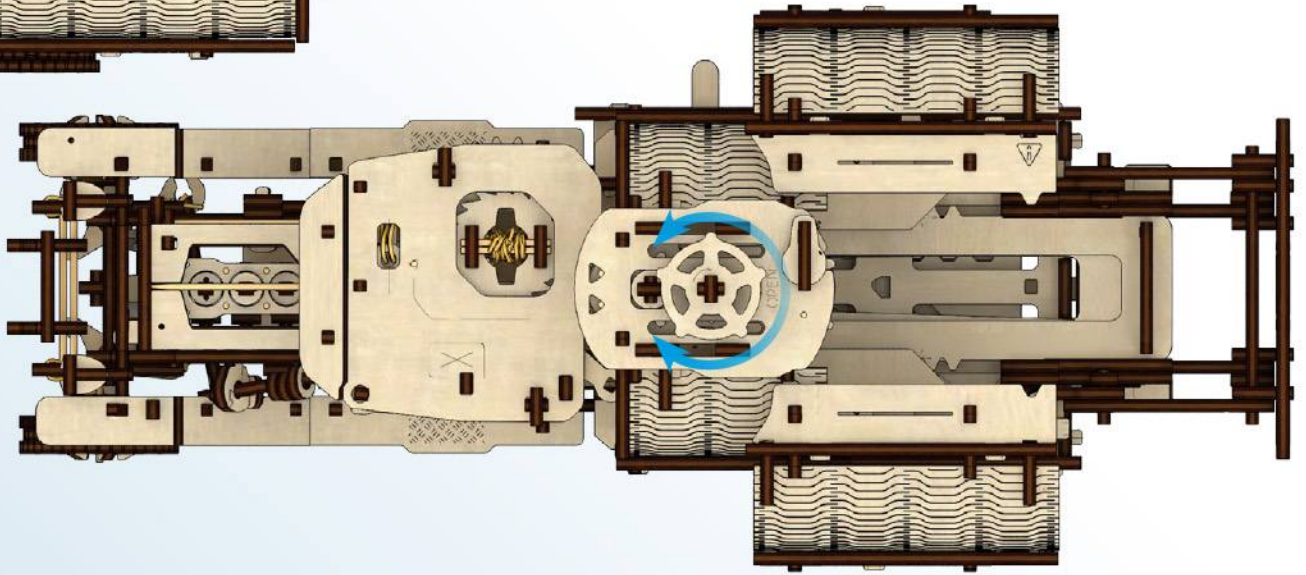
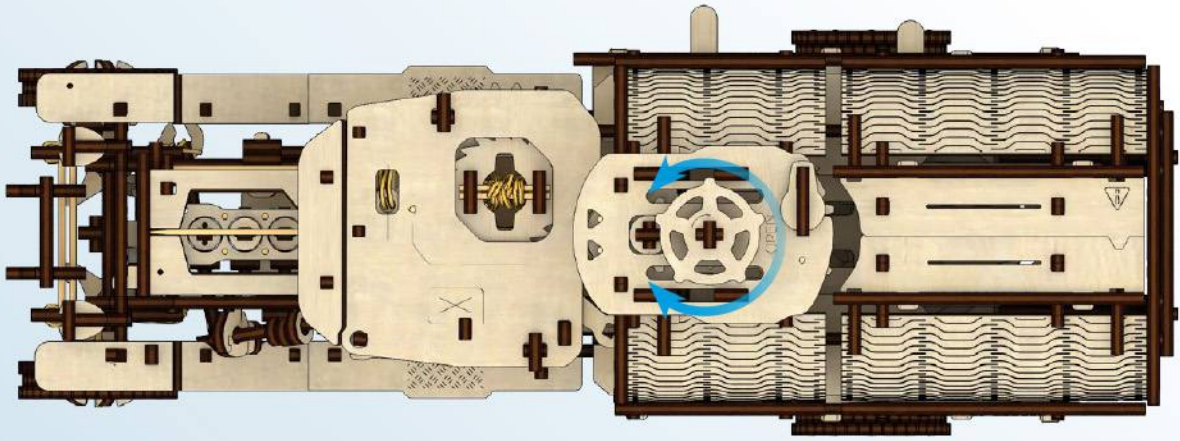

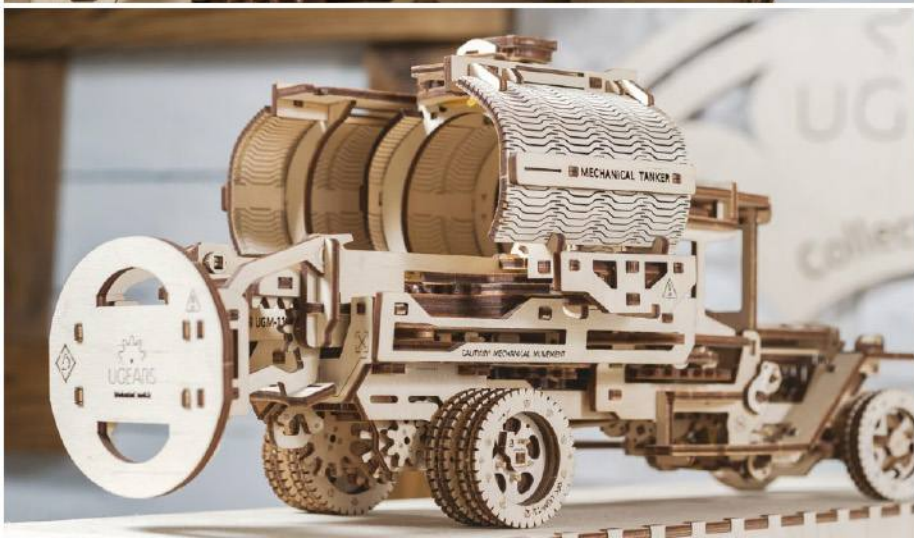



UKR Пожежна драбина. ENG Ladder. DEU Drehleiter. FRA Echelle.
POL Drabina. SPA La escalera. ITA Scala. RUS Пожарная лестница.
JAP はしご. KOR 사다리차. CHI 消防梯



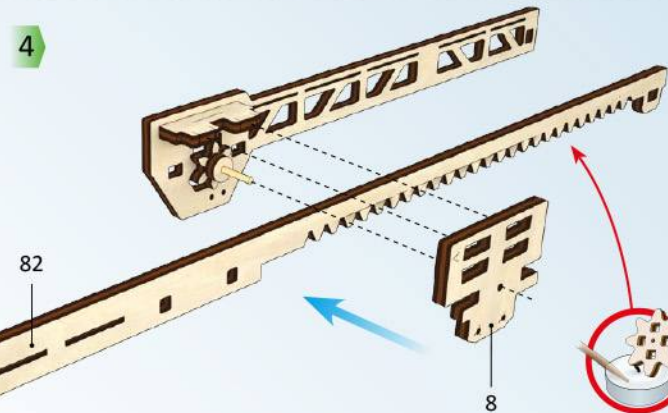
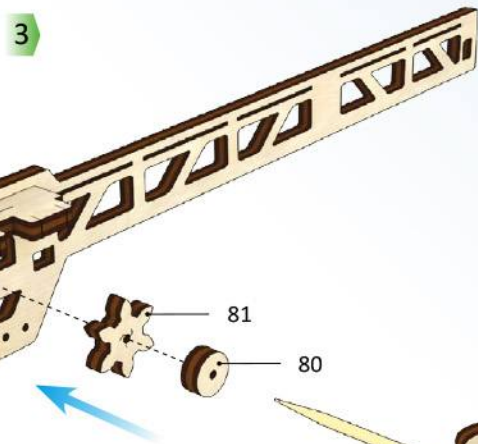
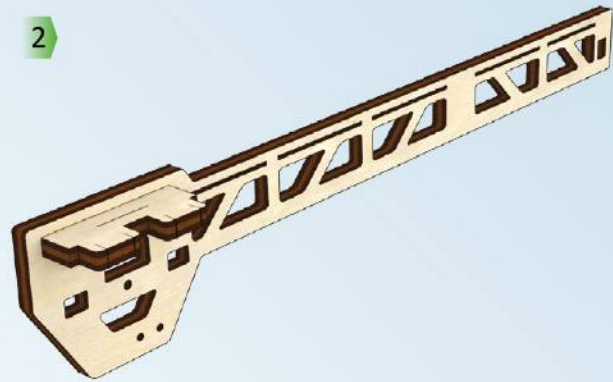
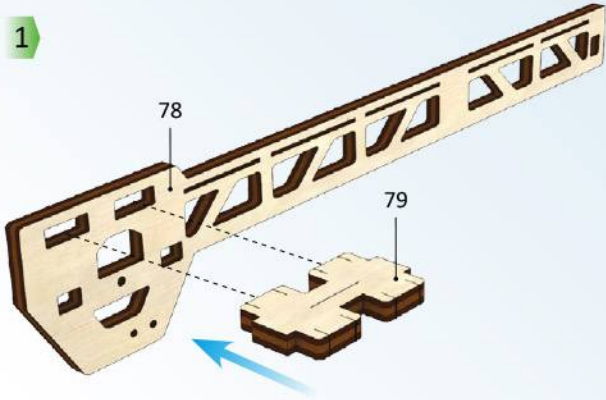
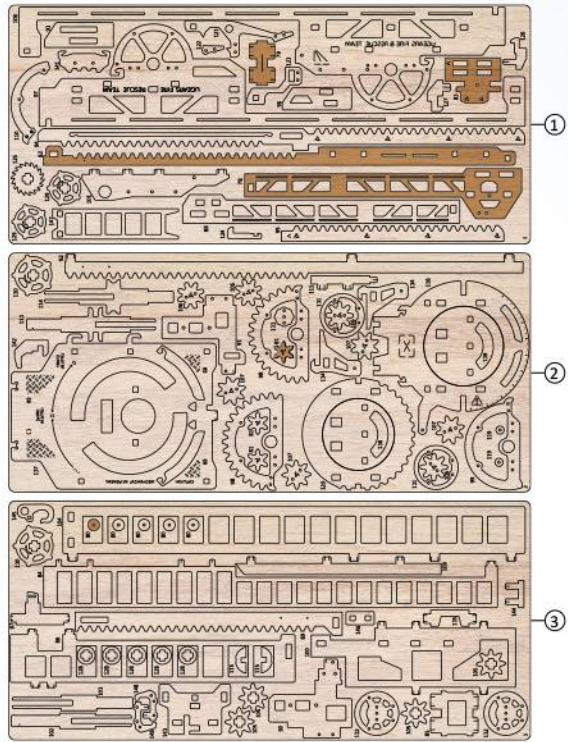

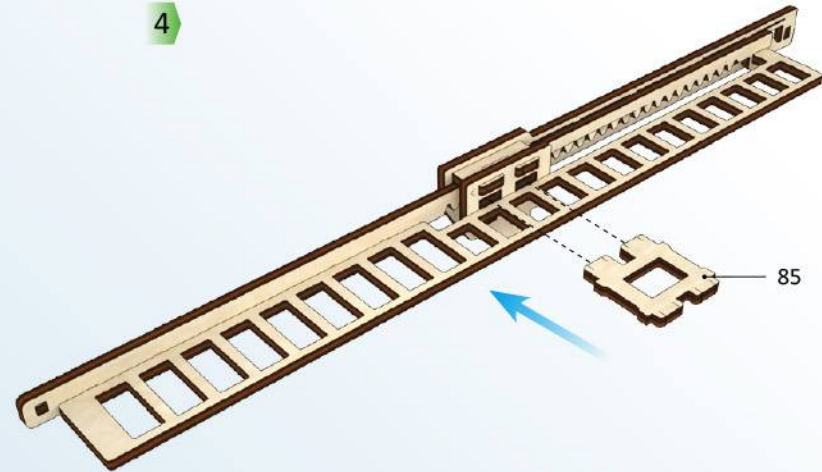
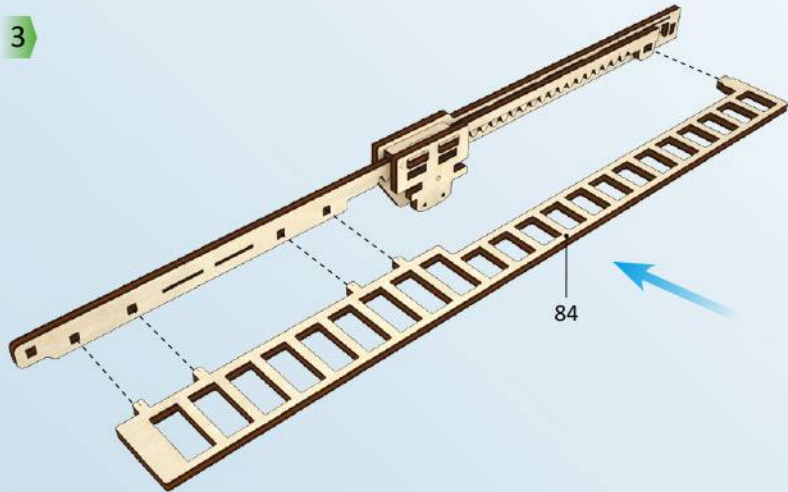
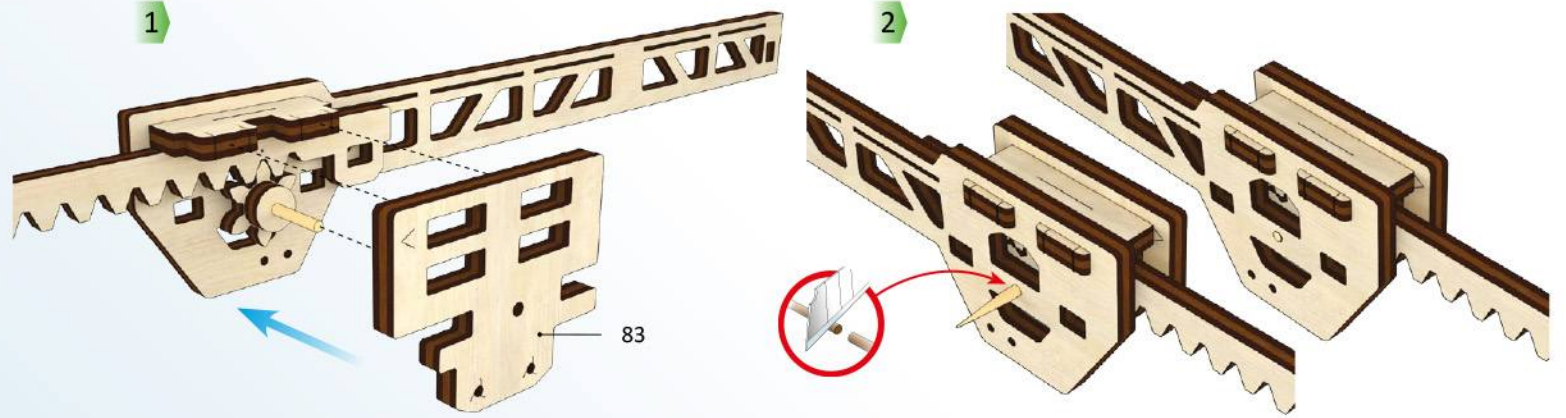
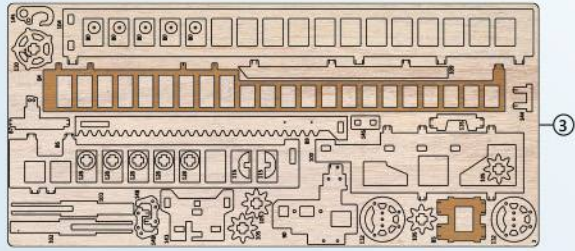

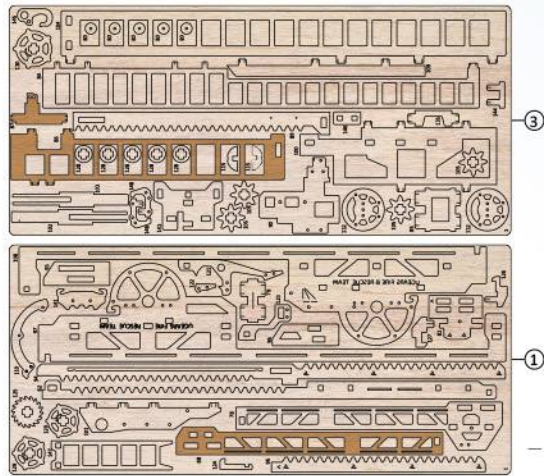

1

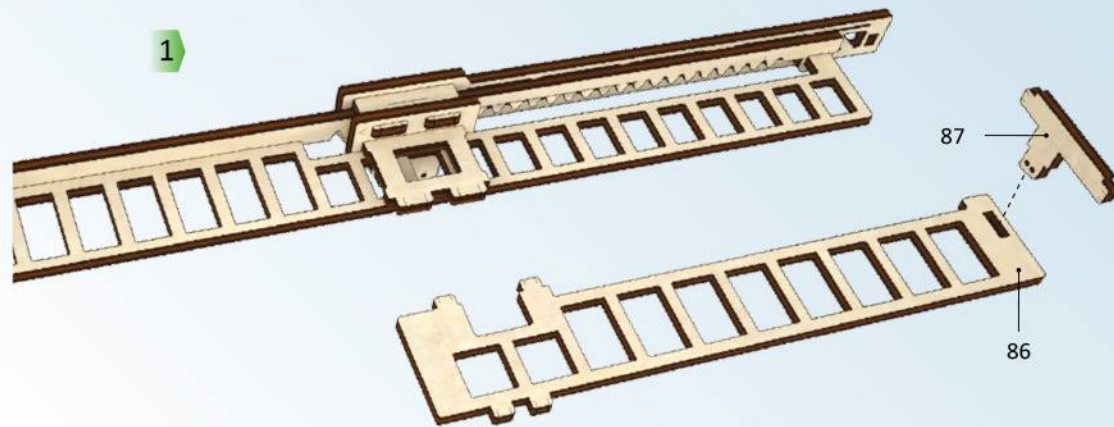

87

86

2

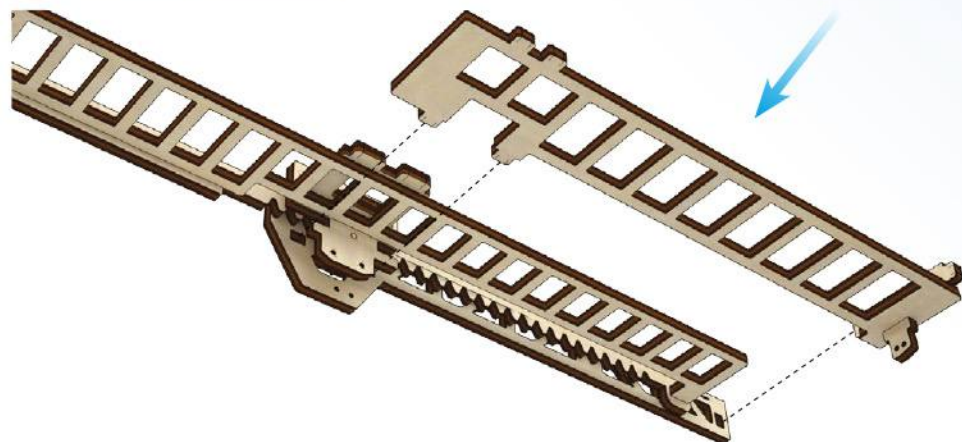

3

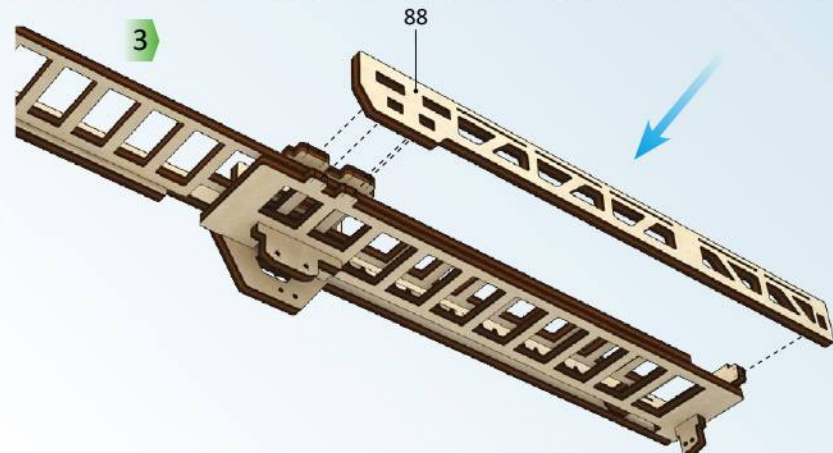

88

Mechanical models

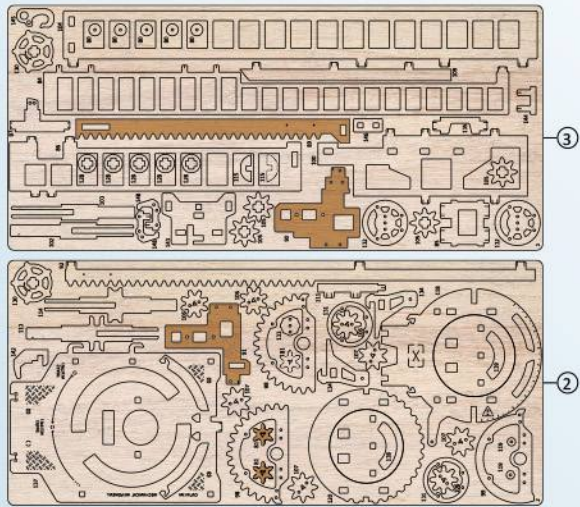

1

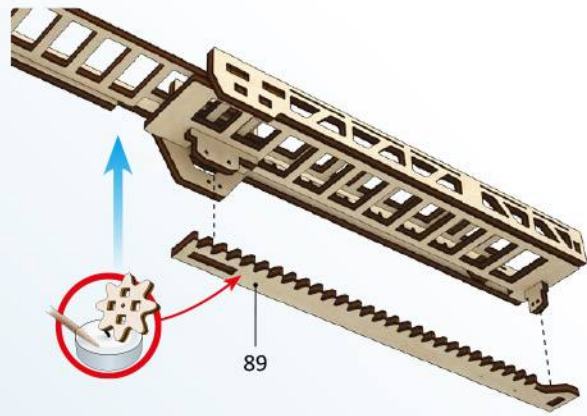

2

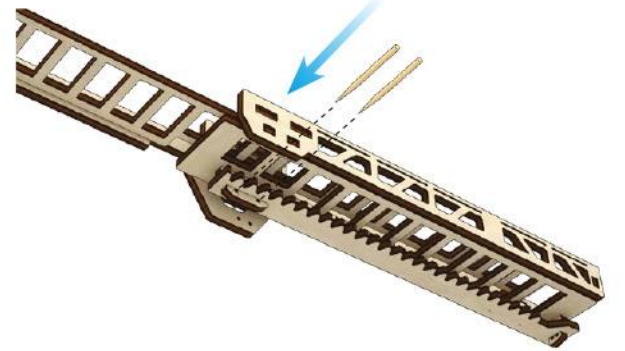

3

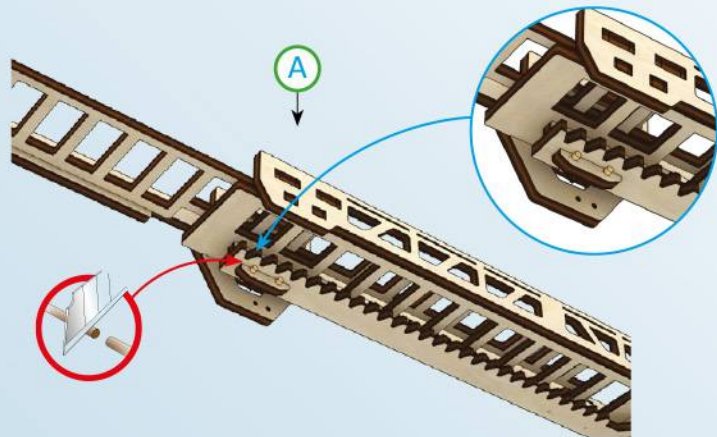

4

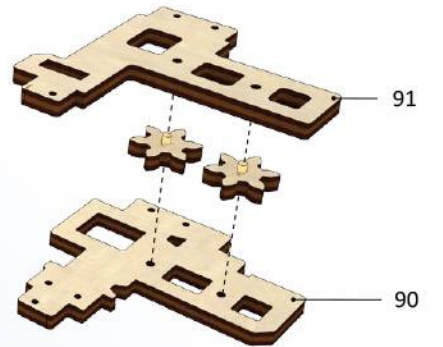
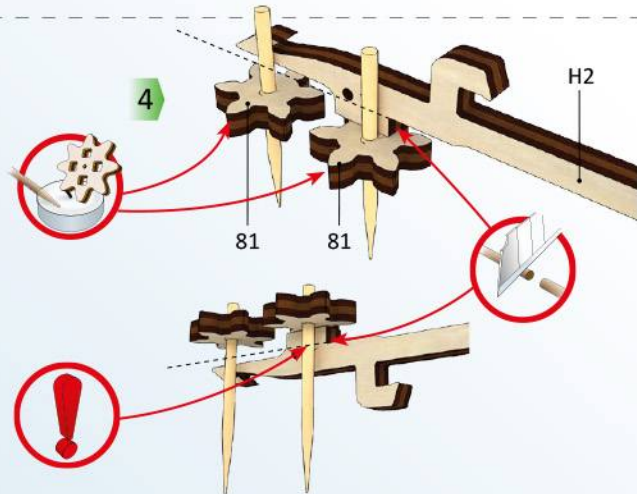

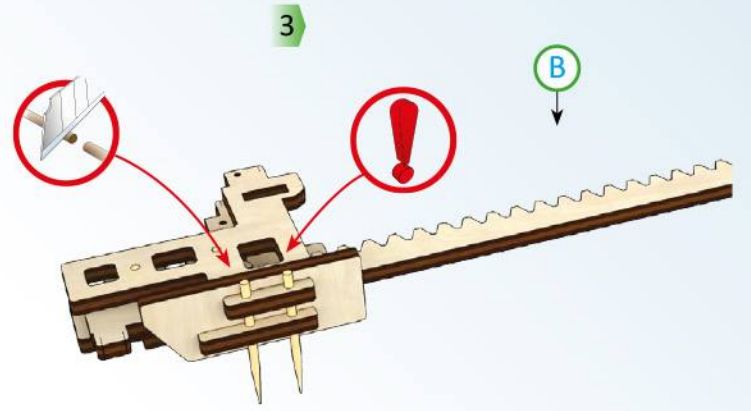
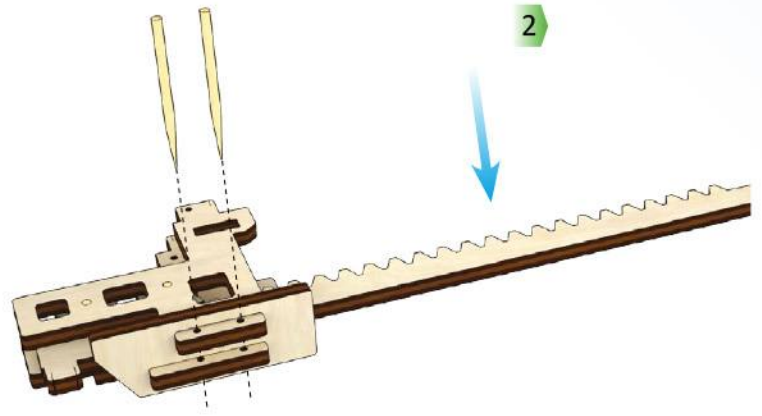
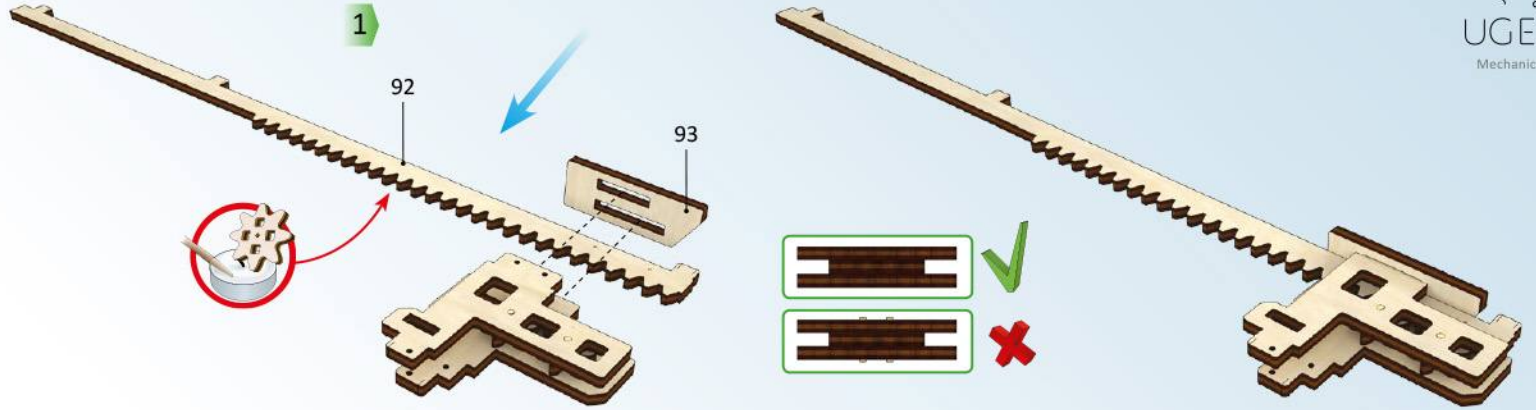
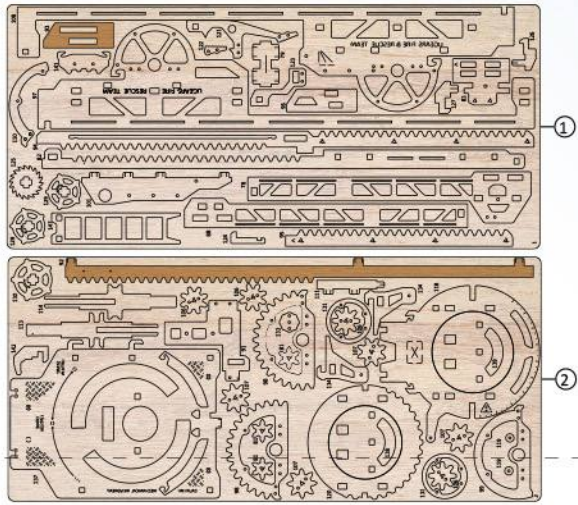

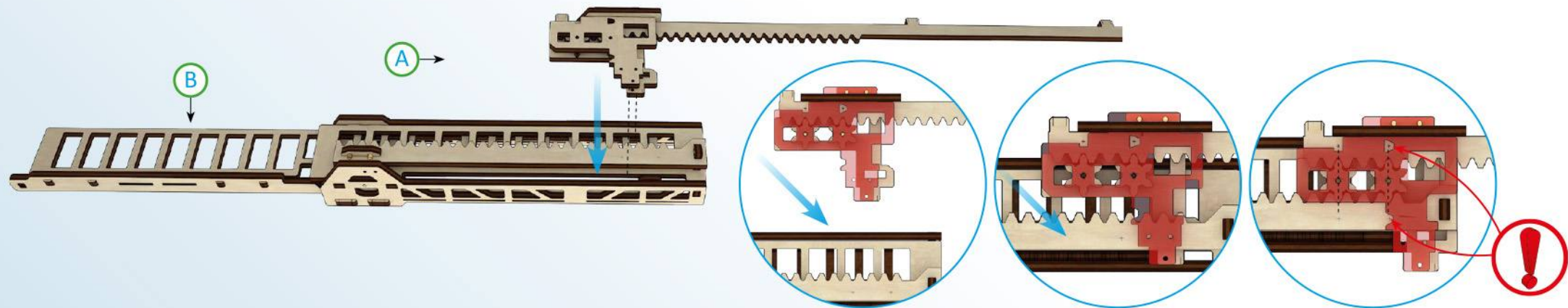

ENG Put the marks together. UKR Поєднайте мітки. DEU Führen Sie die Markierungen zusammen. FRA Alignez les marques. POL Złożyć znaki. SPA Juntará los las marcas. ITA Unire ed assemblare gli incastri. TUR İşaretleri birleştirin. RUS Совместите метки. KOR 표시를 맞춰주세요. CHI 重合标志

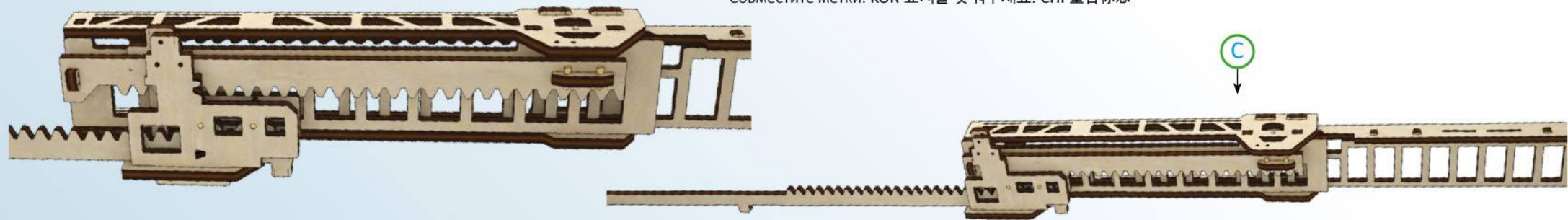

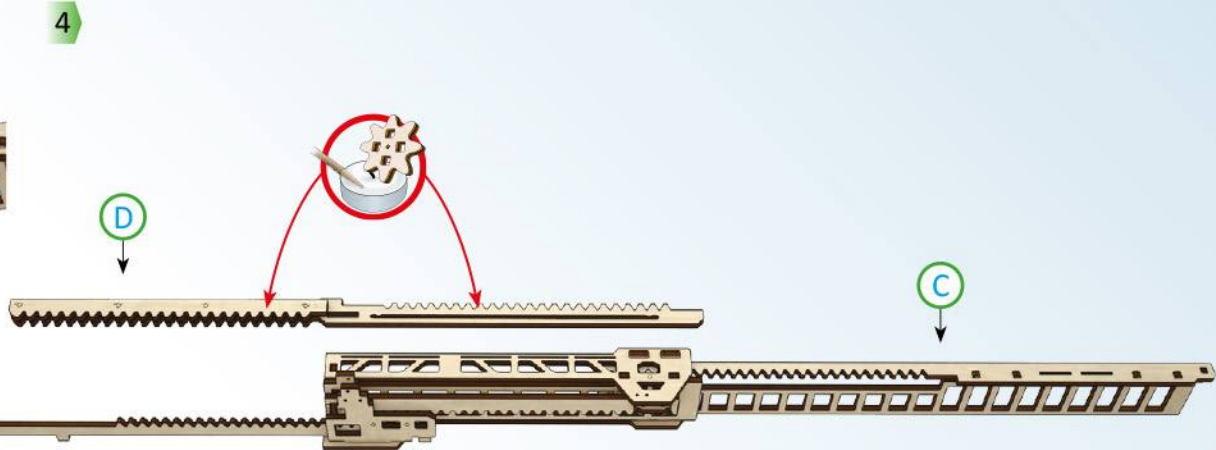
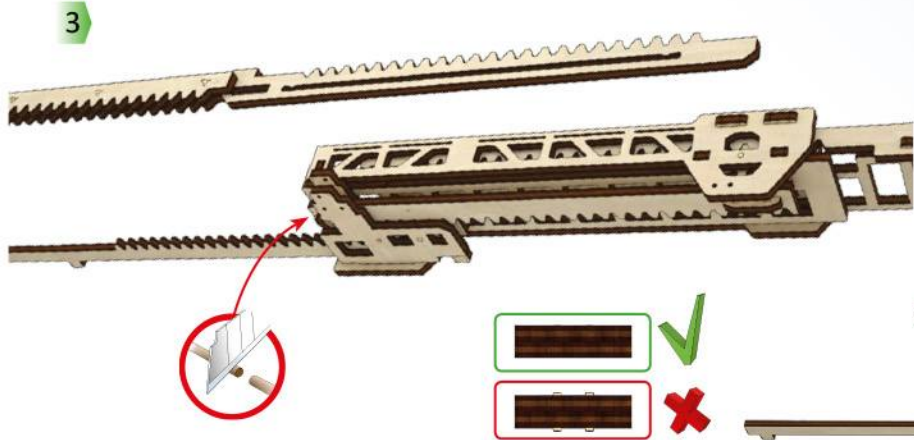
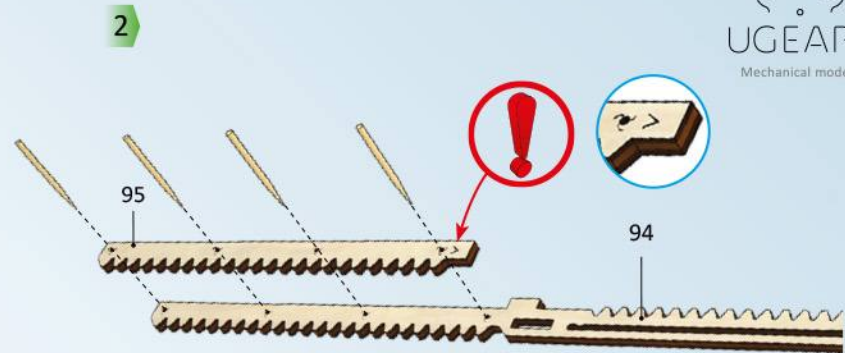
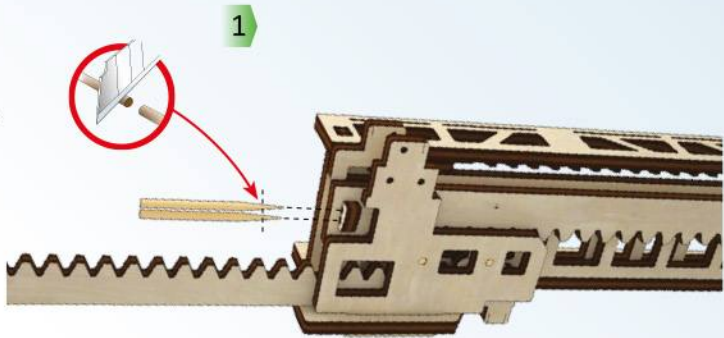
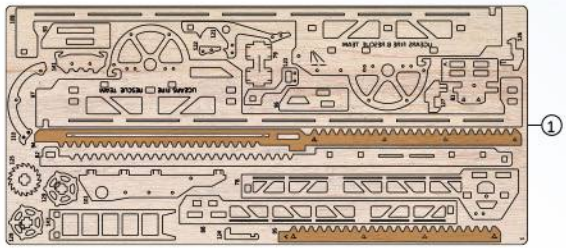

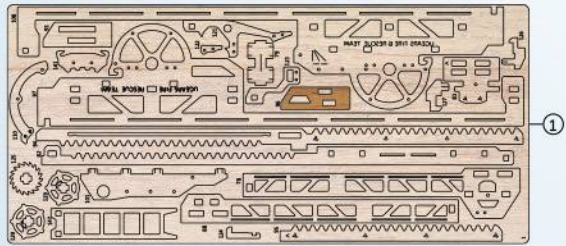

1

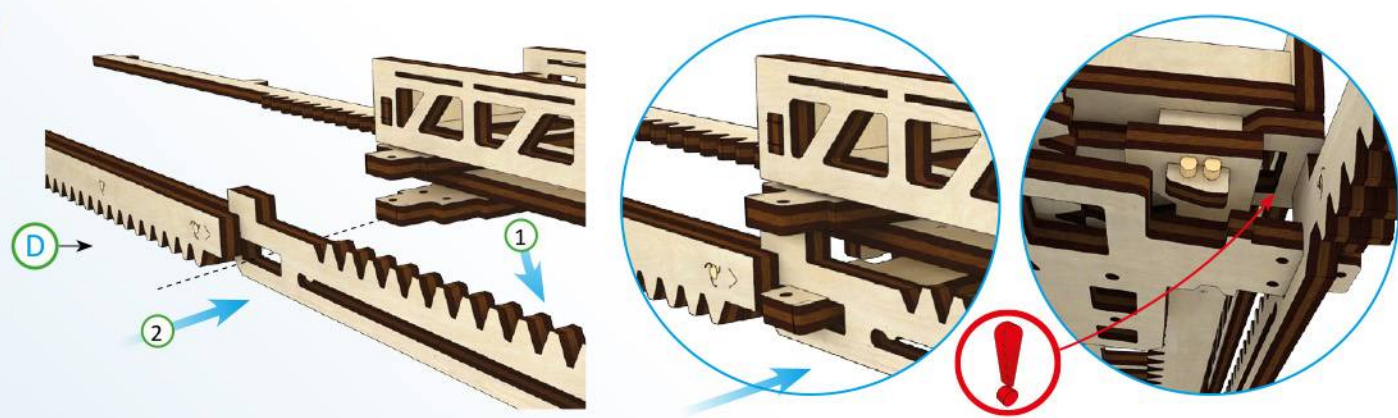

2

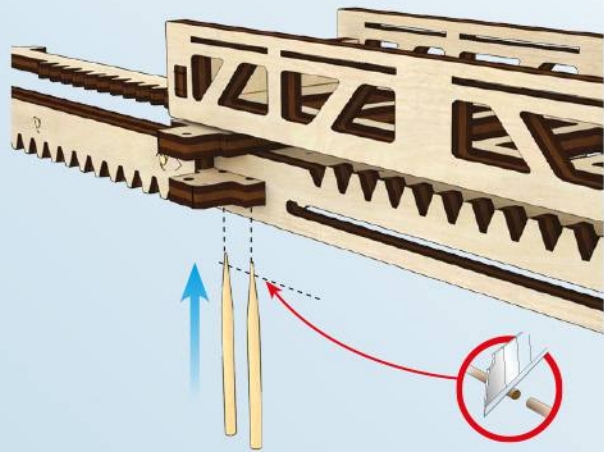

3

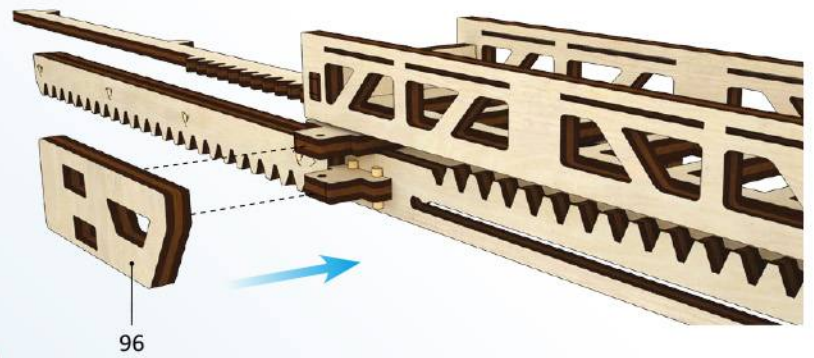
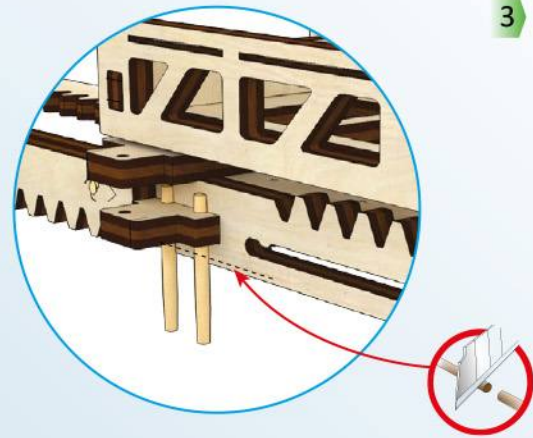

1

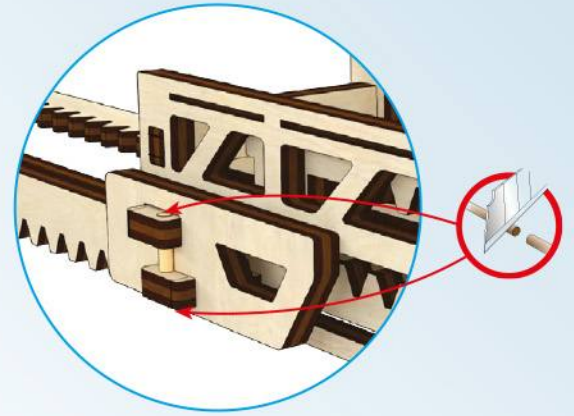
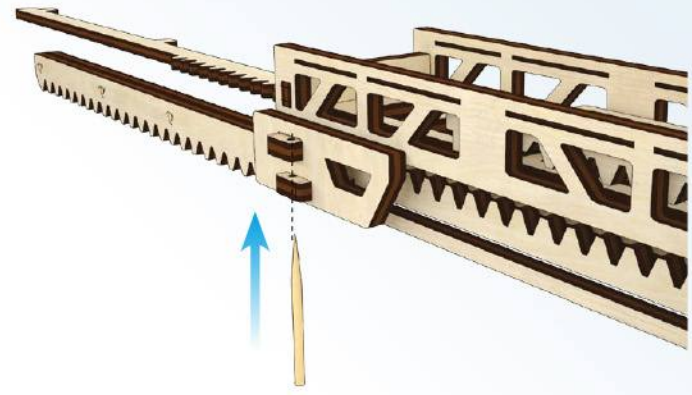

2

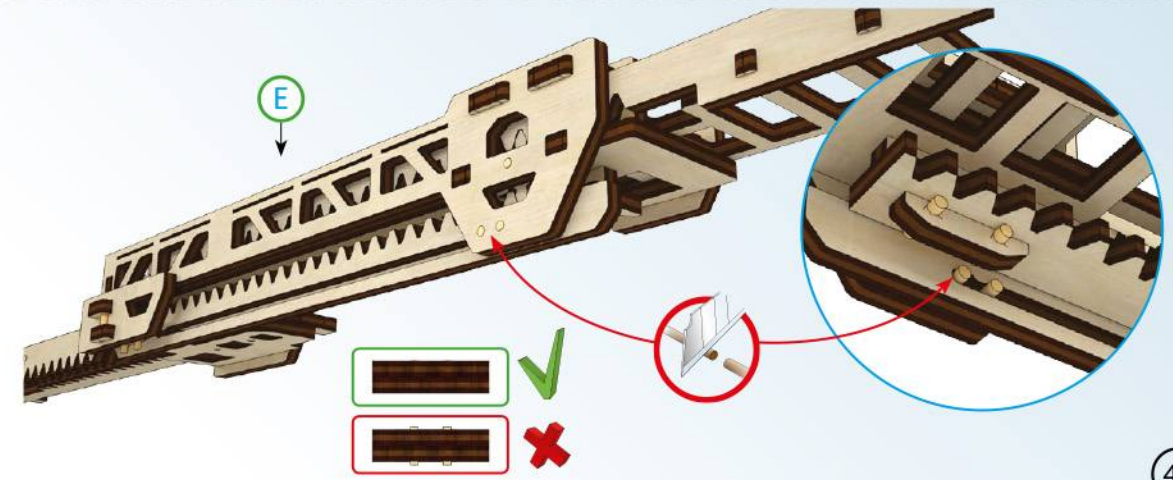
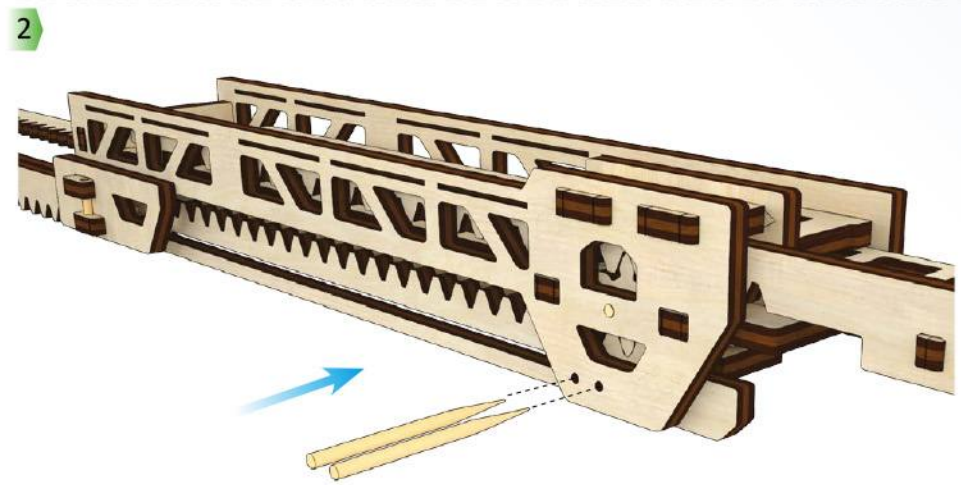

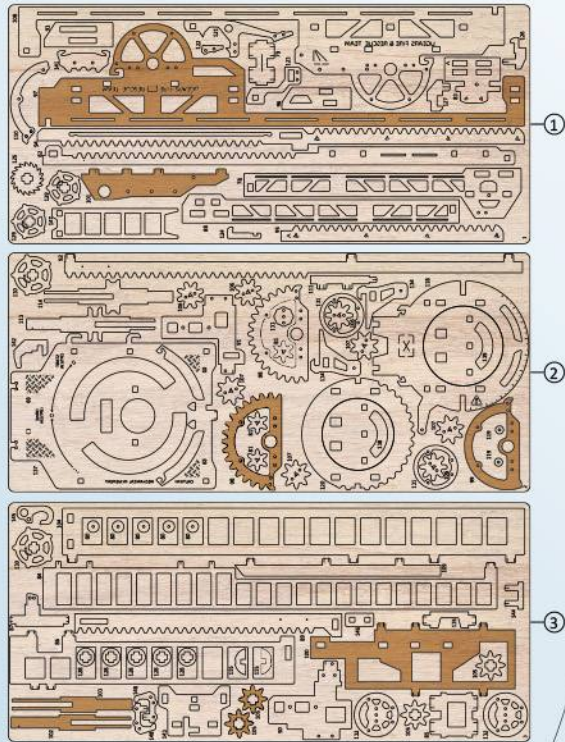

ENG Left side. UKR Ліва сторона. DEU Linke Seite. FRA Côté gauche. POL Lewa strona. SPA El lado izquierdo. ITA Parte sinistra. RUS Левая сторона. JAP 左側. KOR 좌측면. CHI 左侧.

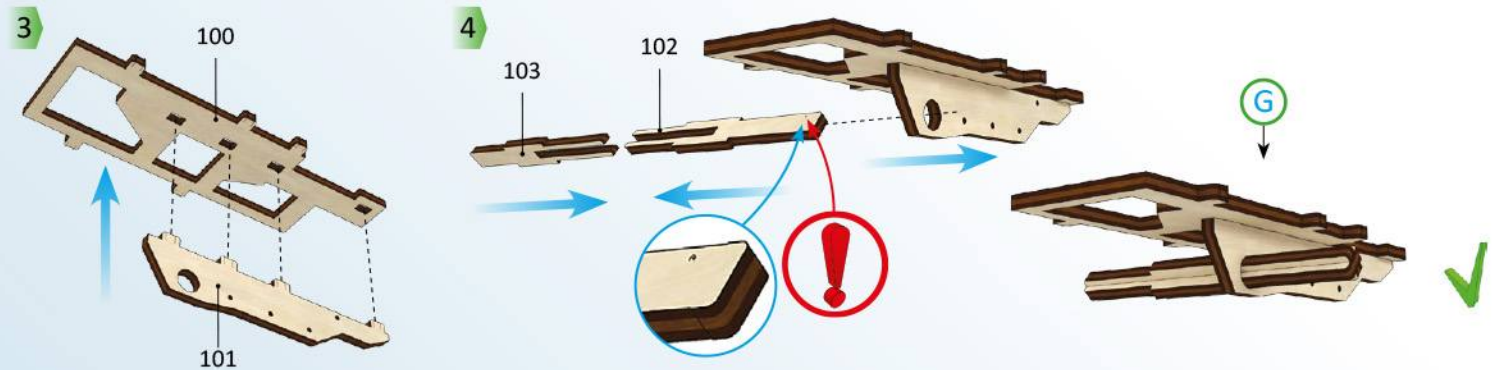
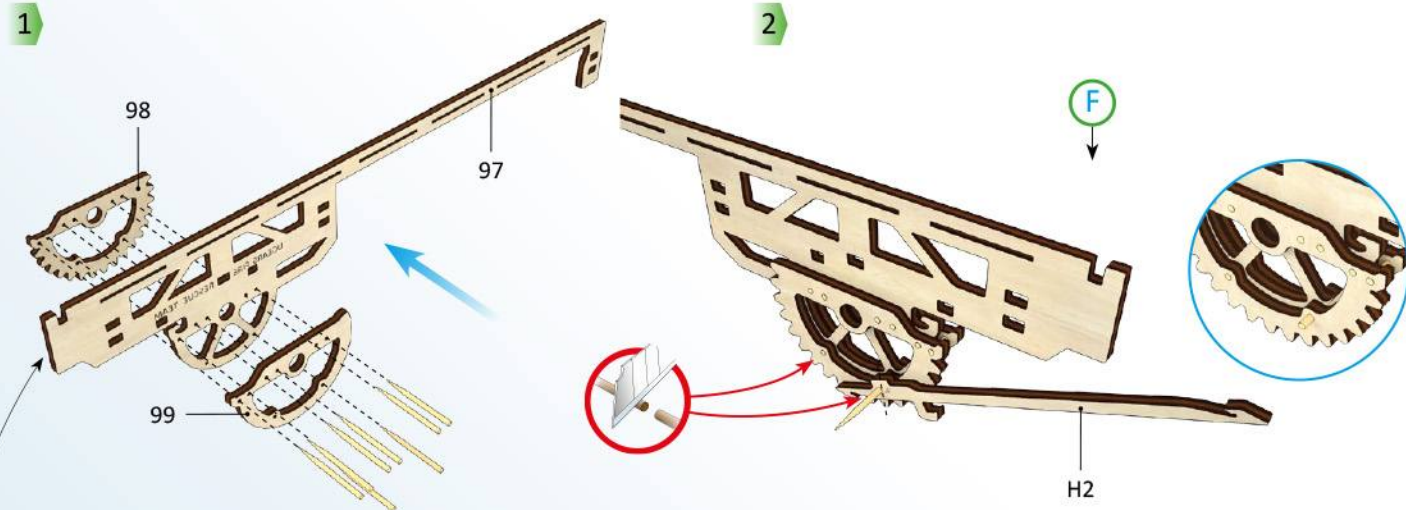

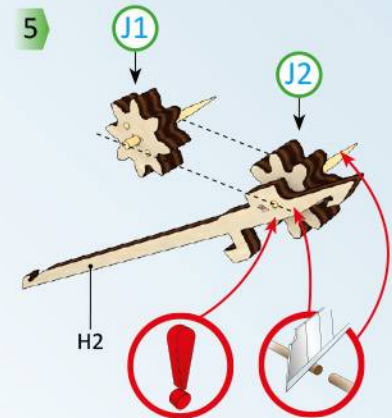
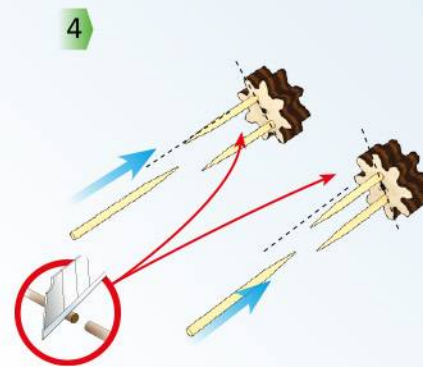
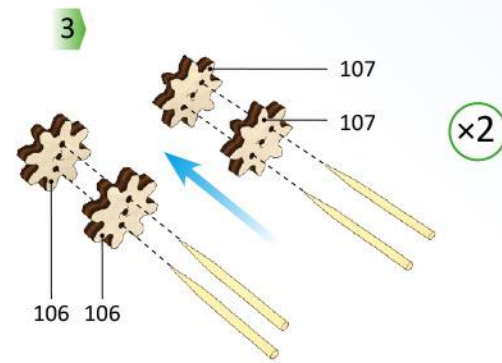
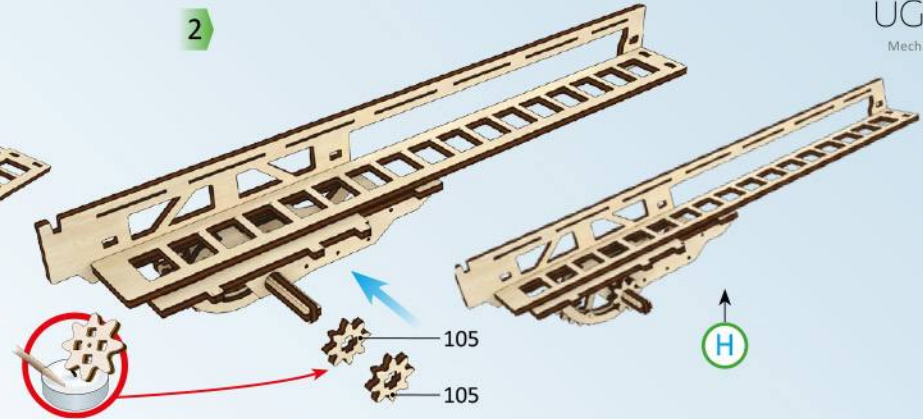
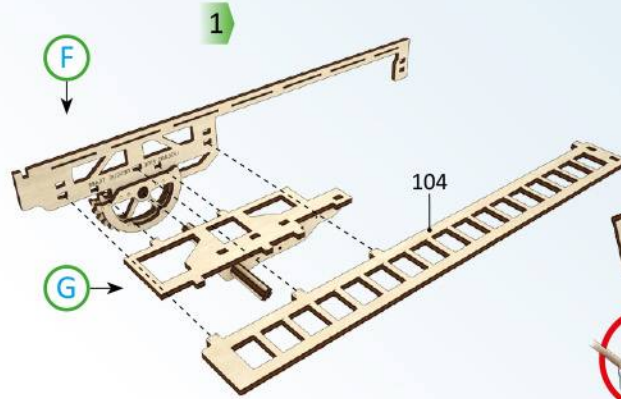
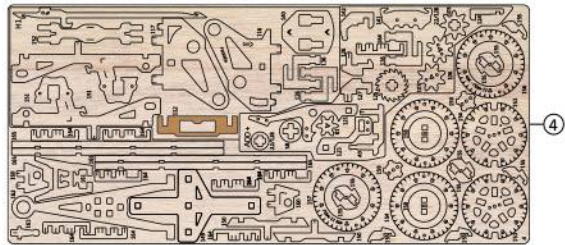
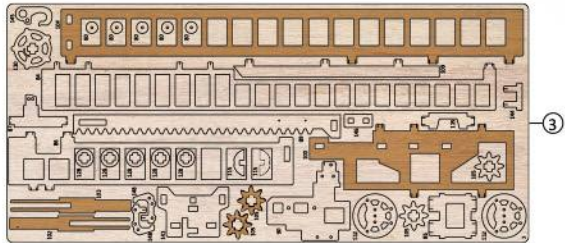
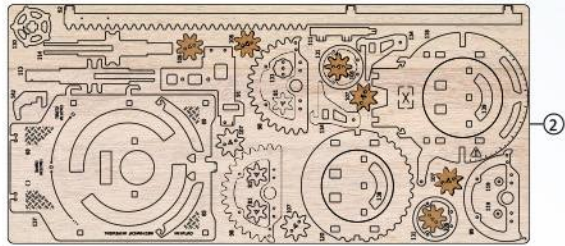

Mechanical models

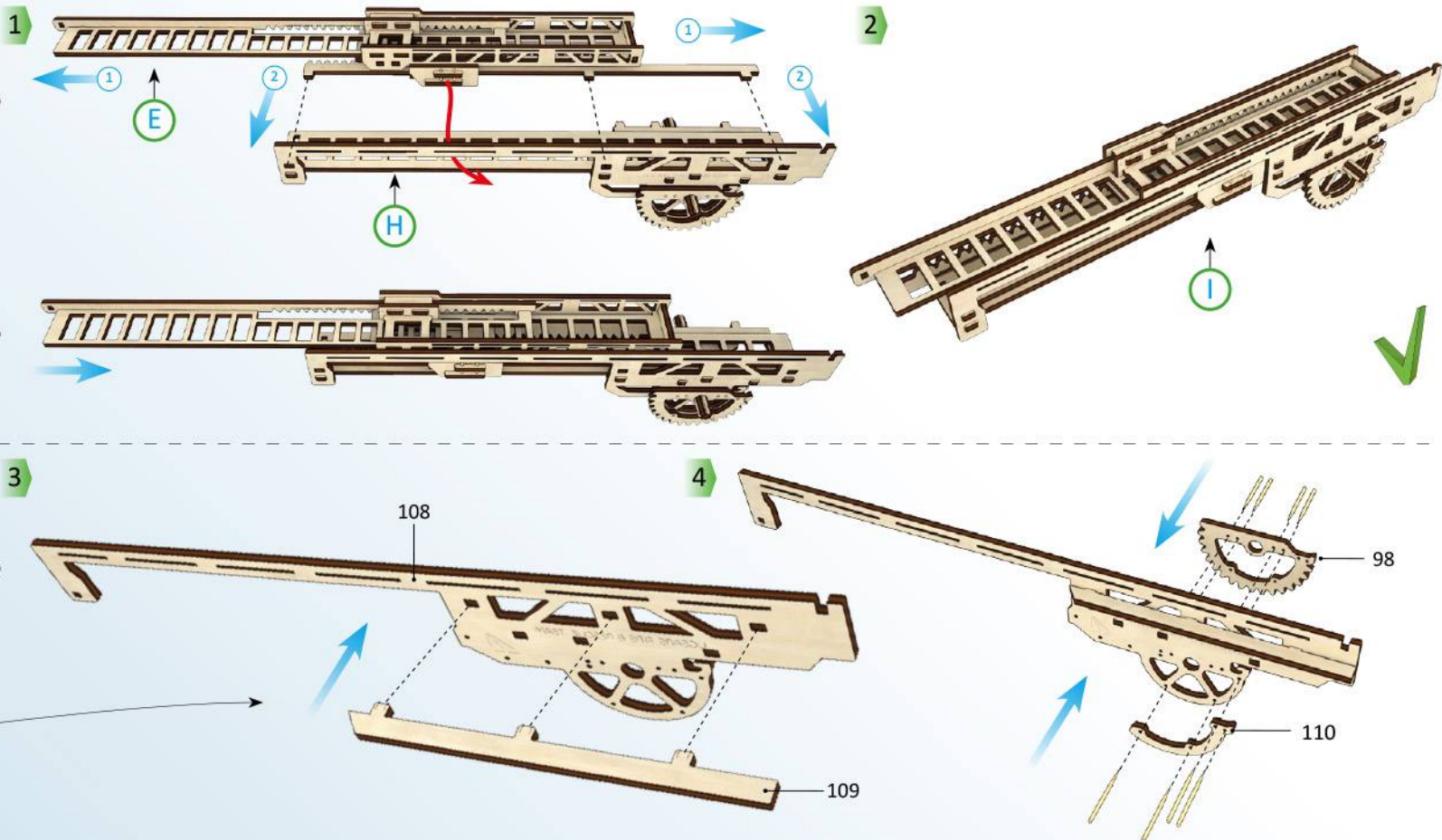
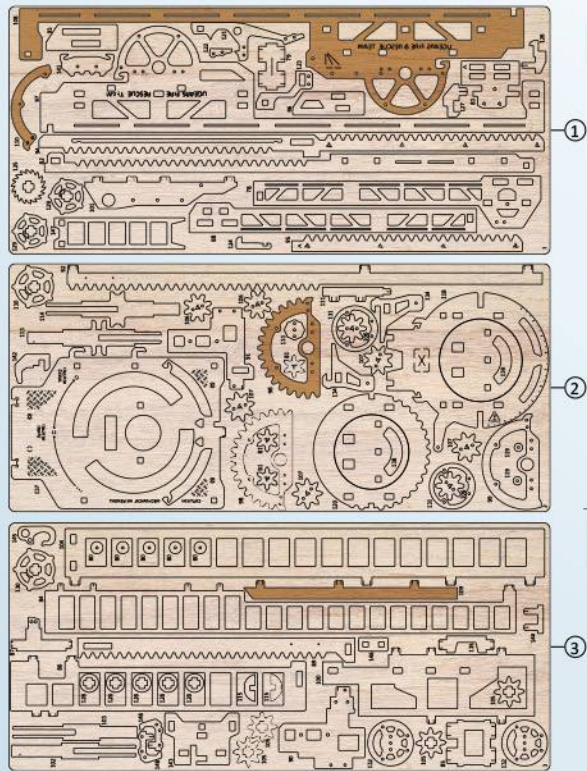

ENG Right side. UKR Права сторона. DEU Rechte Seite.
 FRA Côté droit. POL Prawa strona. SPA El lado derecho.
 ITA Parte destra. RUS Правая сторона. JAP 右侧.
 KOR 우측면. CHI 右侧.

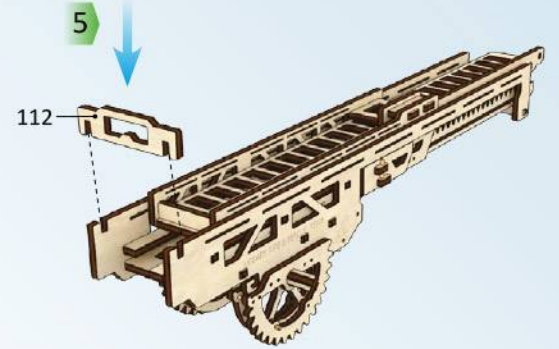
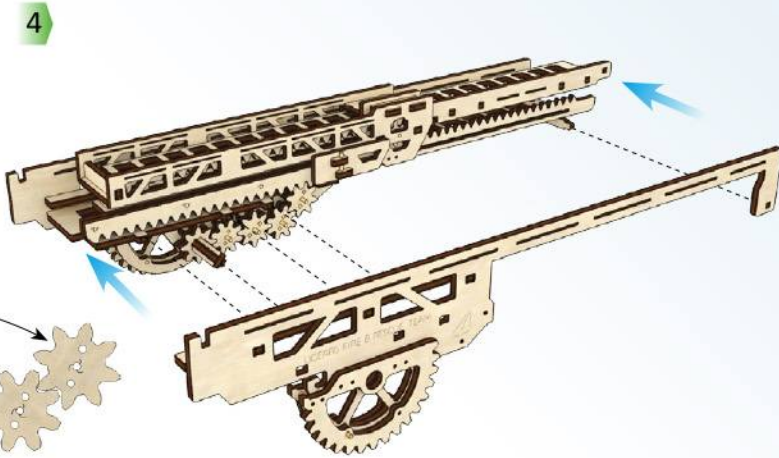
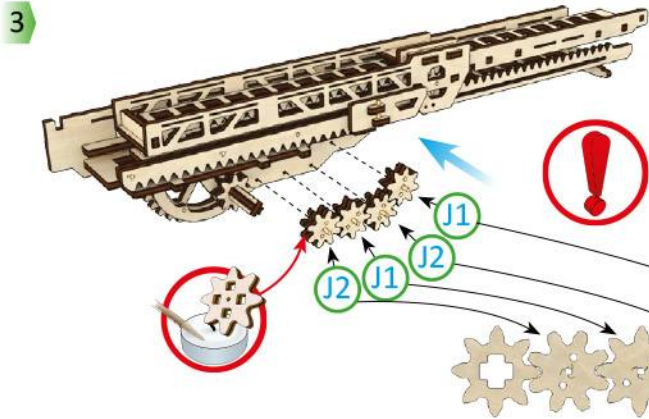
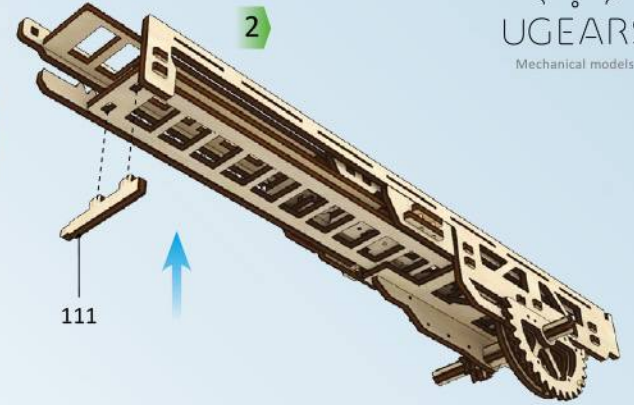
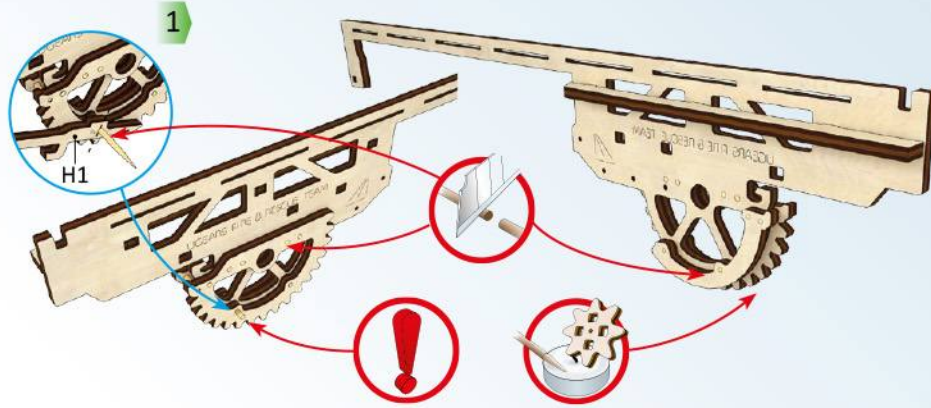
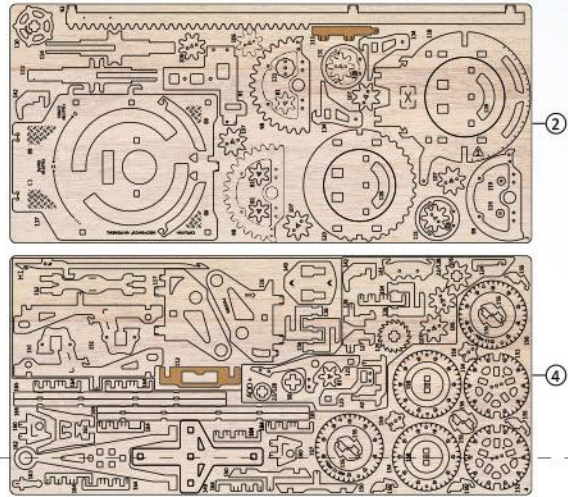

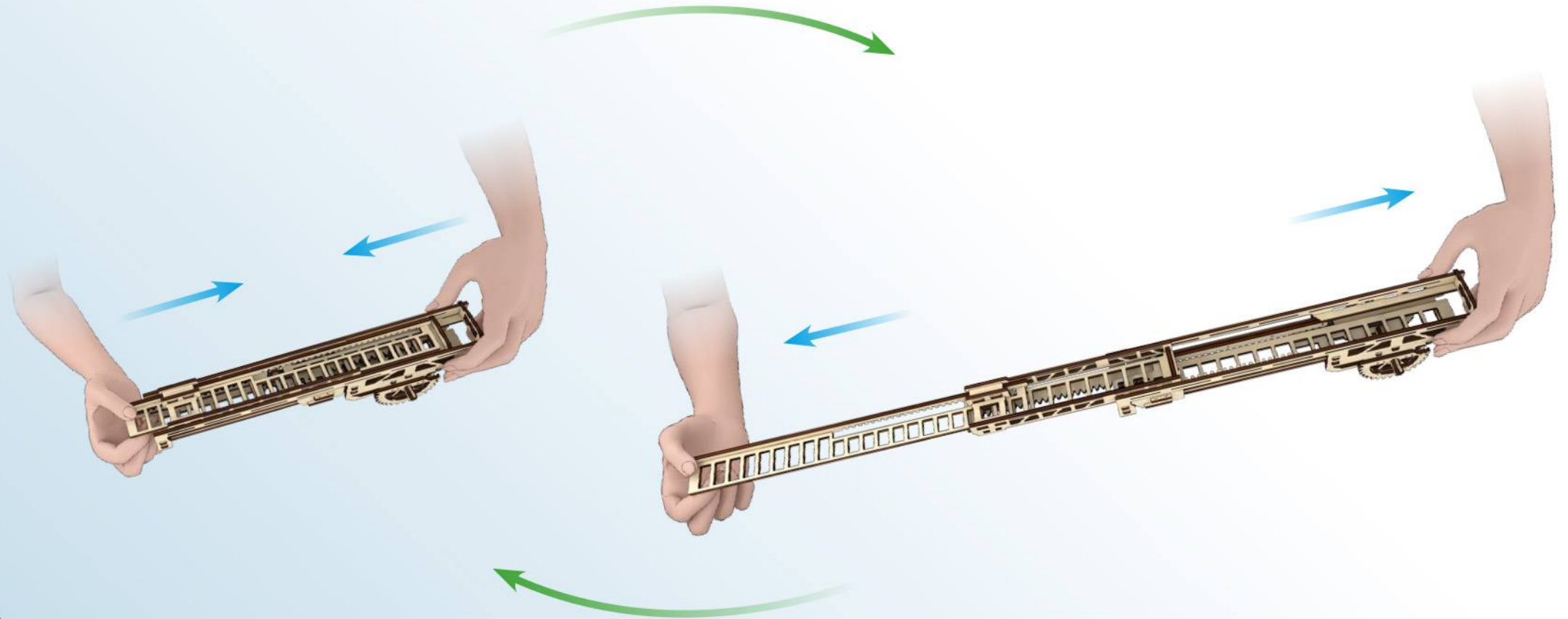

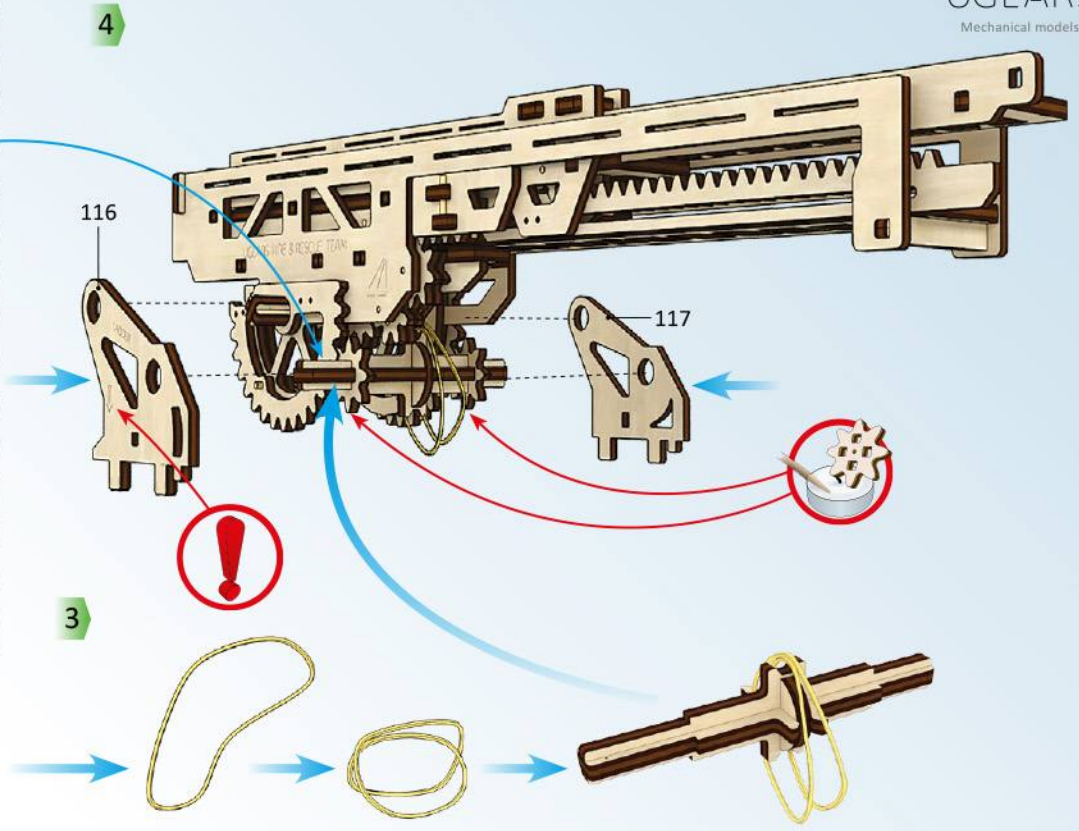
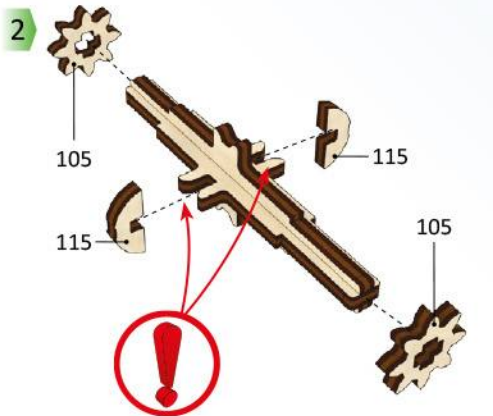
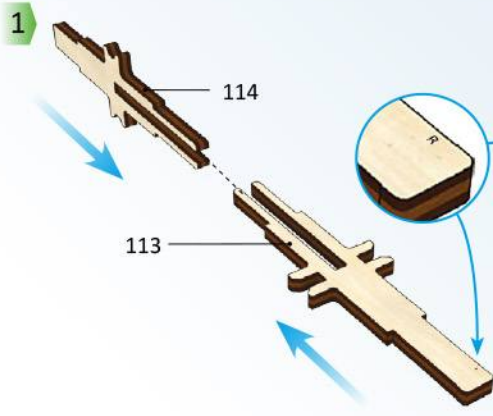
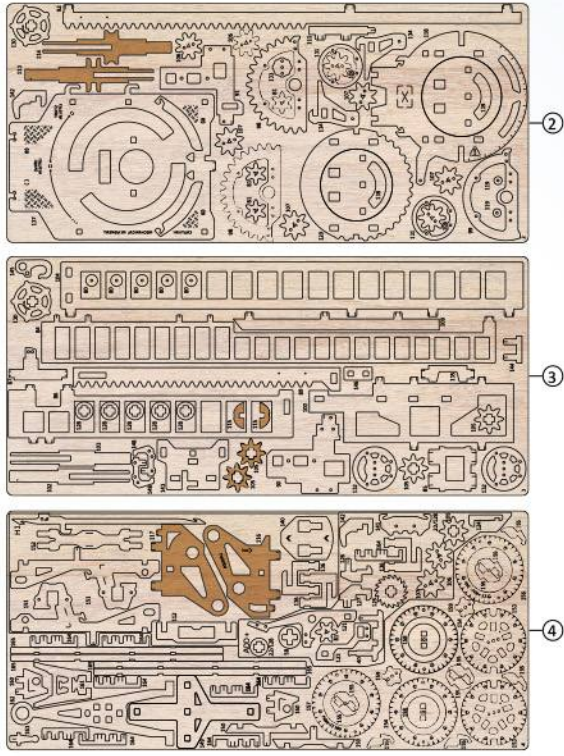

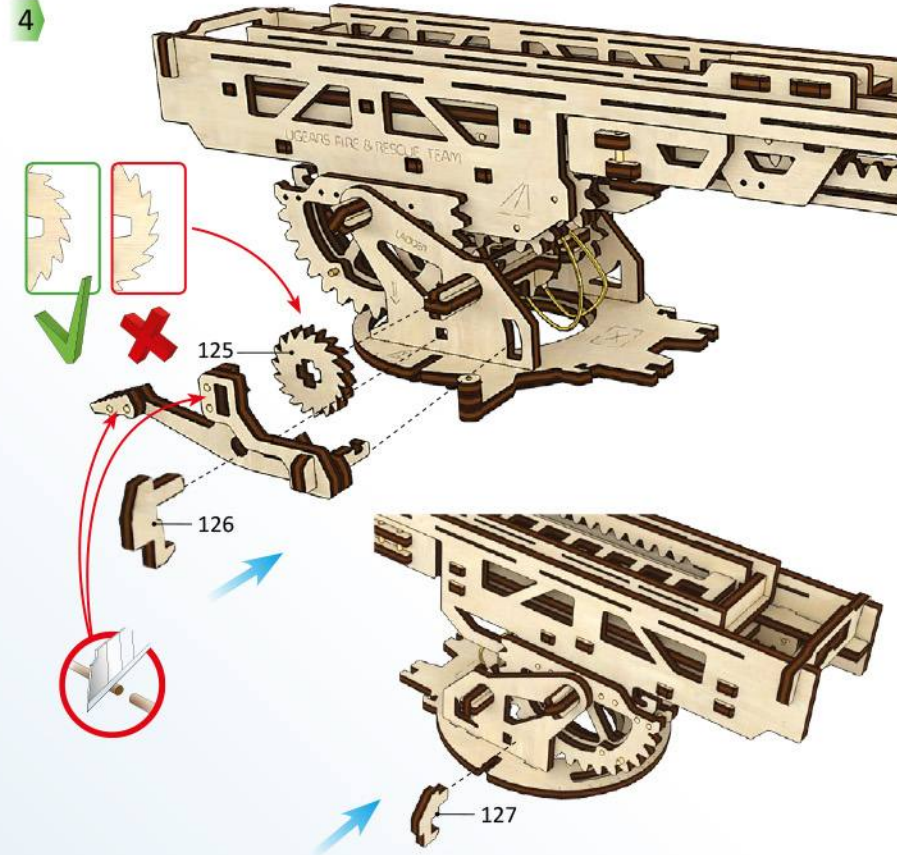
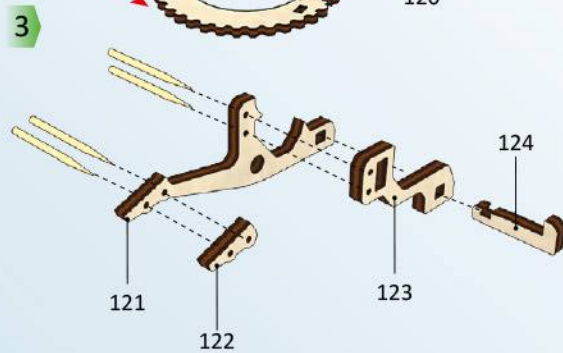
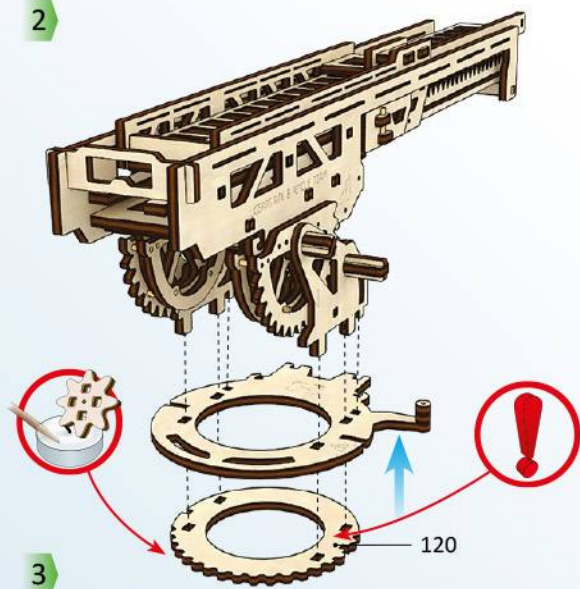
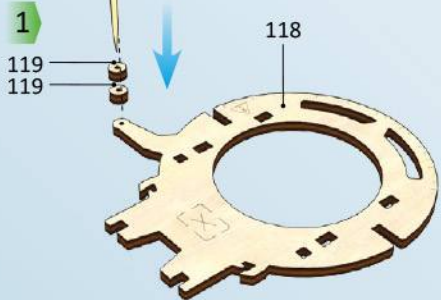
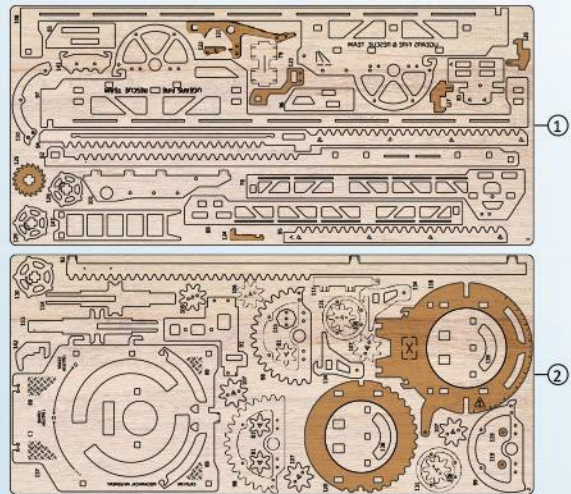

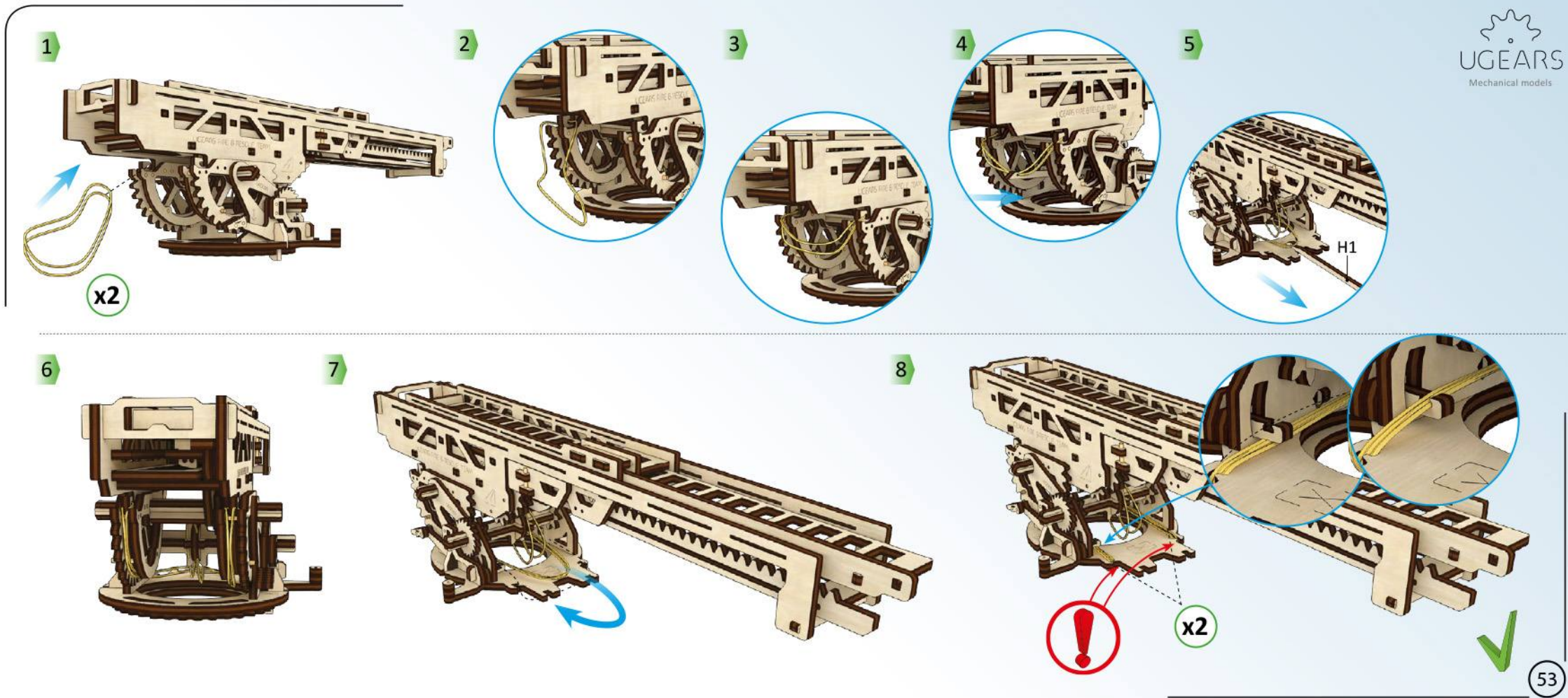

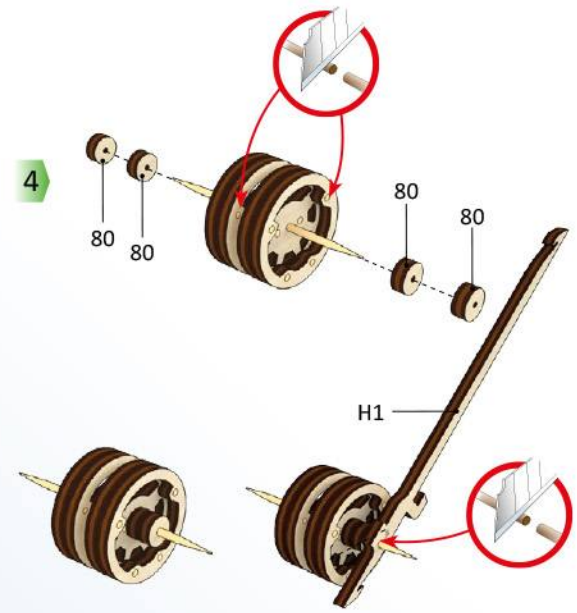
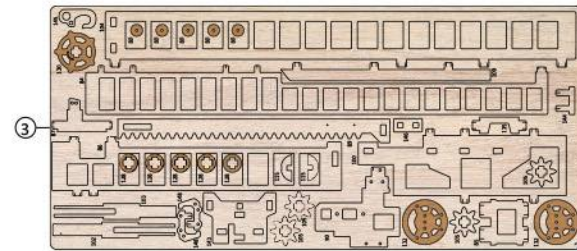
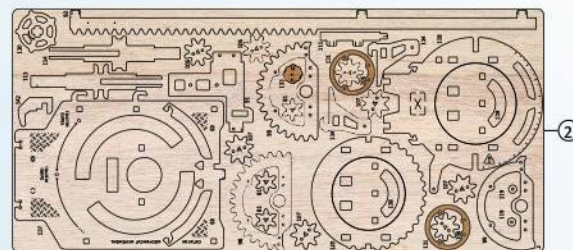
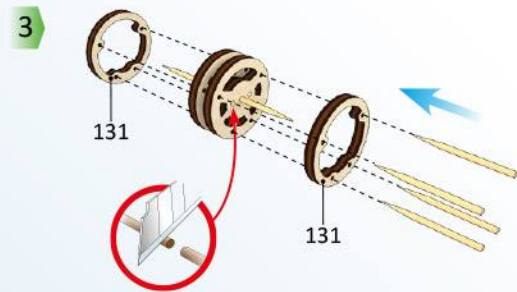
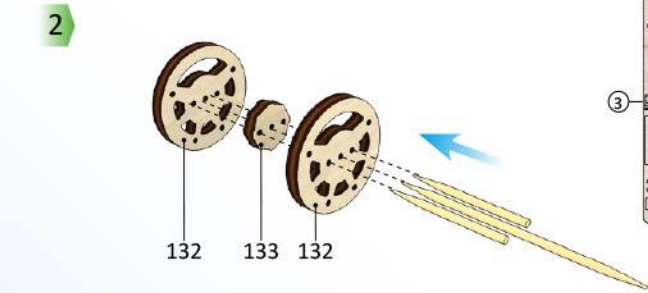
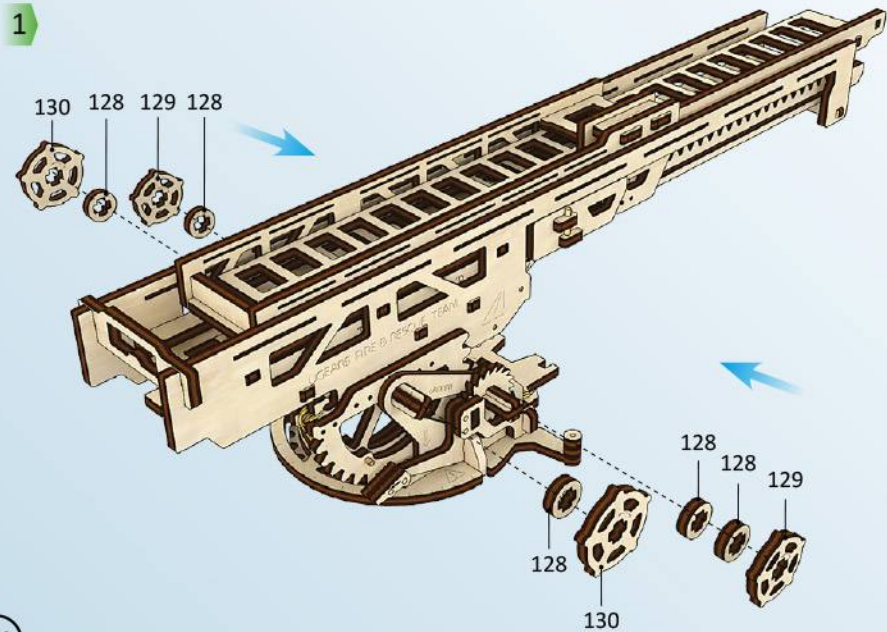
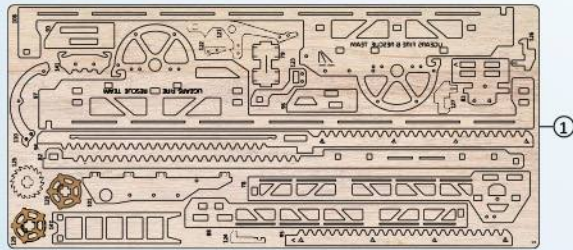

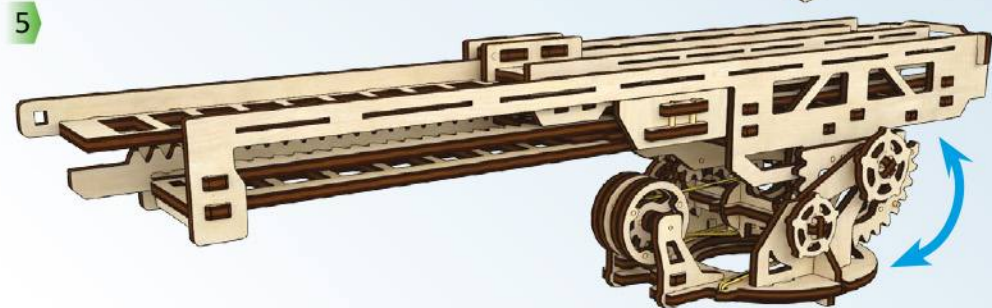
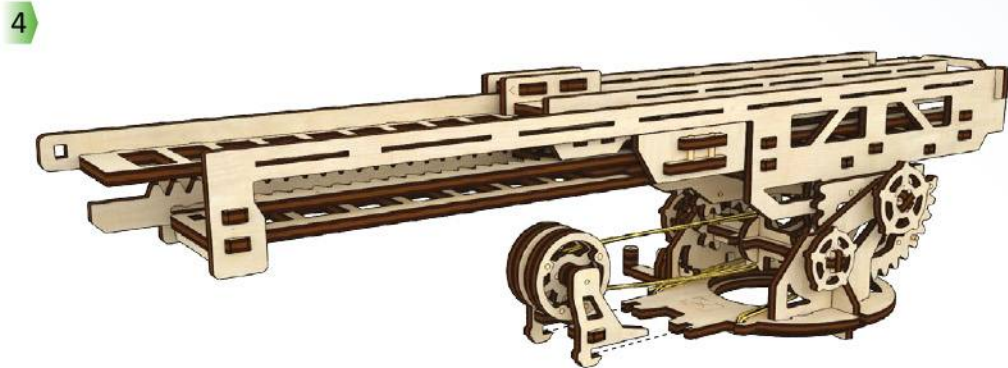
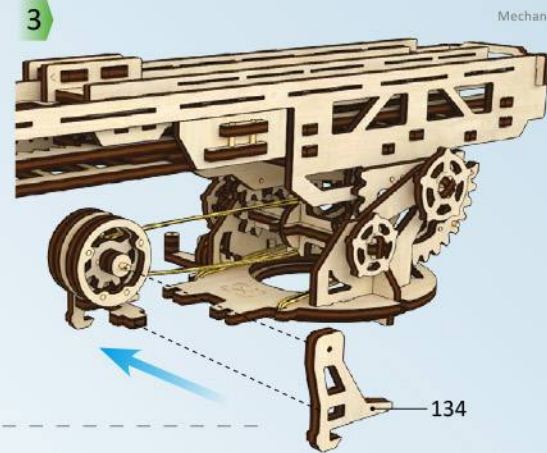
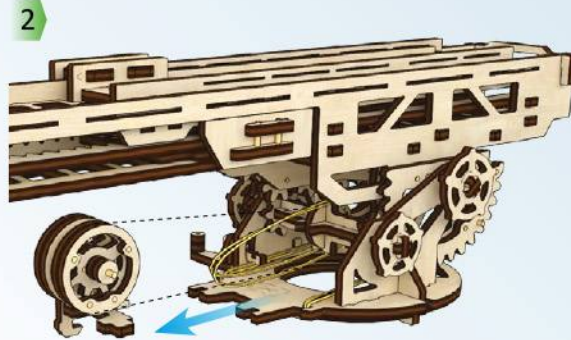
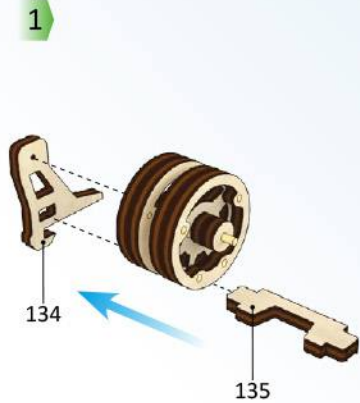
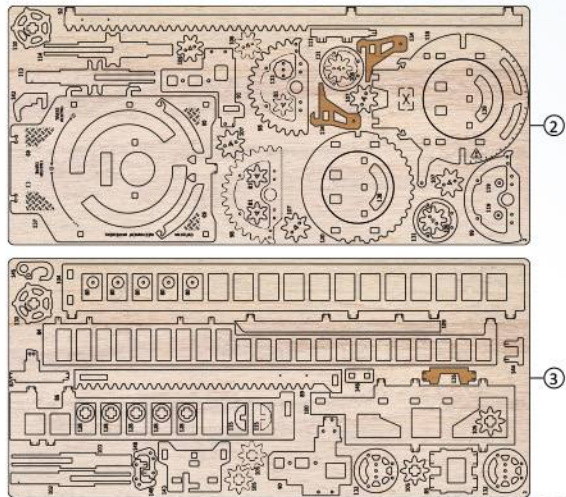

ENG Neatly turn it around. **UKR** Аккуратно поверніть. **DEU** Einmal vorsichtig umdrehen. **FRA** Tournez doucement. **POL** Starannie obróćić dookoła. **SPA** Cuidadosamente déle la vuelta. **ITA** Girare con la dovuta calma. **RUS** Аккуратно поверните. **JAP** スムーズに回らないといけません。 **KOR** 부드럽게 돌아가야 합니다. **CHI** 轻轻地旋动。

1



2



3

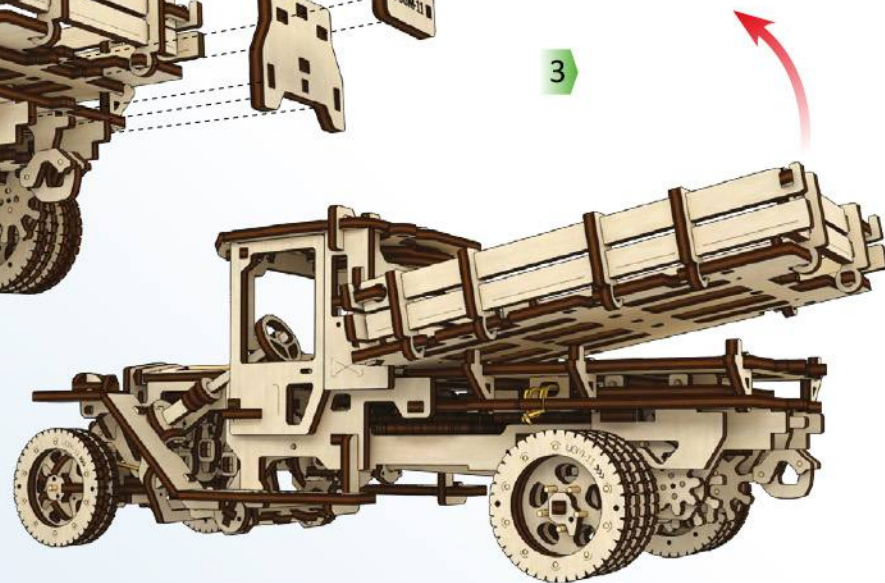

ENG Carefully remove the car body. UKR Аккуратно зніміть кузов. DEU Entfernen Sie vorsichtig den Pritschenaufbau. FRA Retirez délicatement la carrosserie du camion. POL Delikatnie zdjąć karoserię. SPA Extraiga cuidadosamente el cuerpo del coche. ITA Rimuovere il cassone con la dovuta calma. RUS Аккуратно демонтируйте кузов. JAP 注意しながら車の本体をお外してください。トレーラー KOR 적재함을 조심스럽게 분리해 주세요. CHI 小心地拆卸车体。

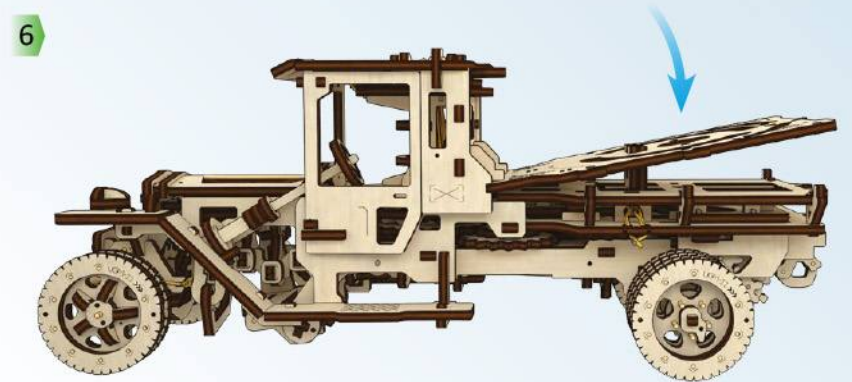
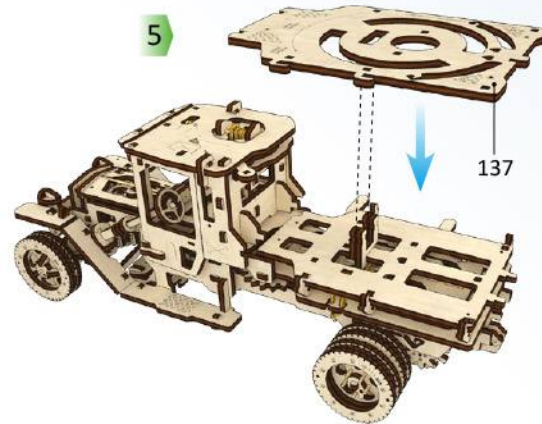
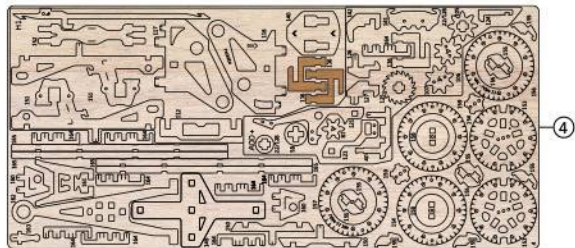
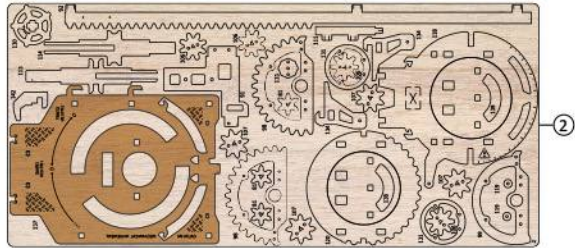
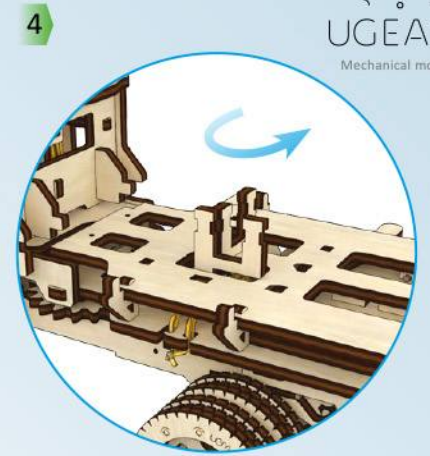
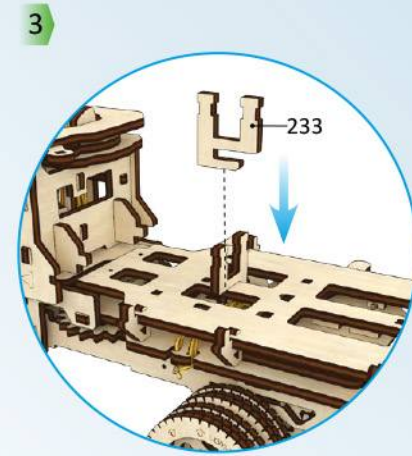
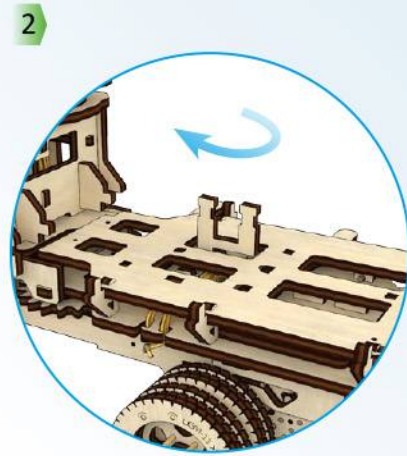
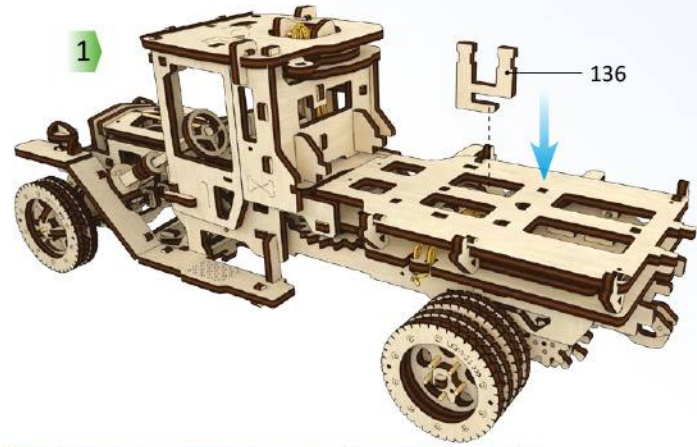

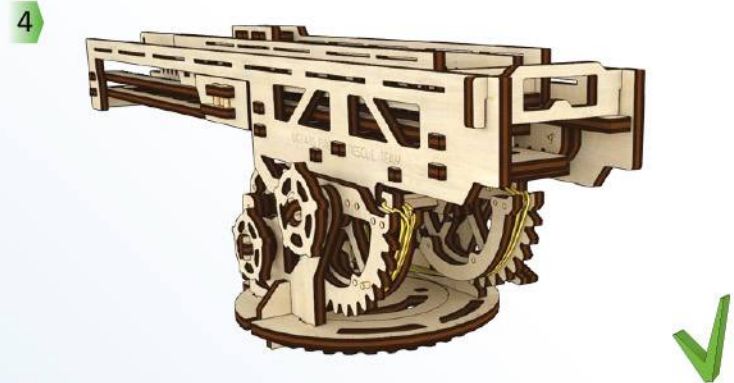
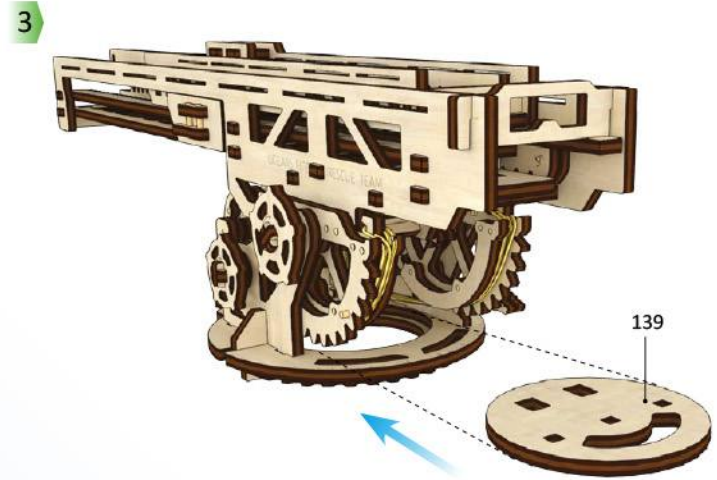
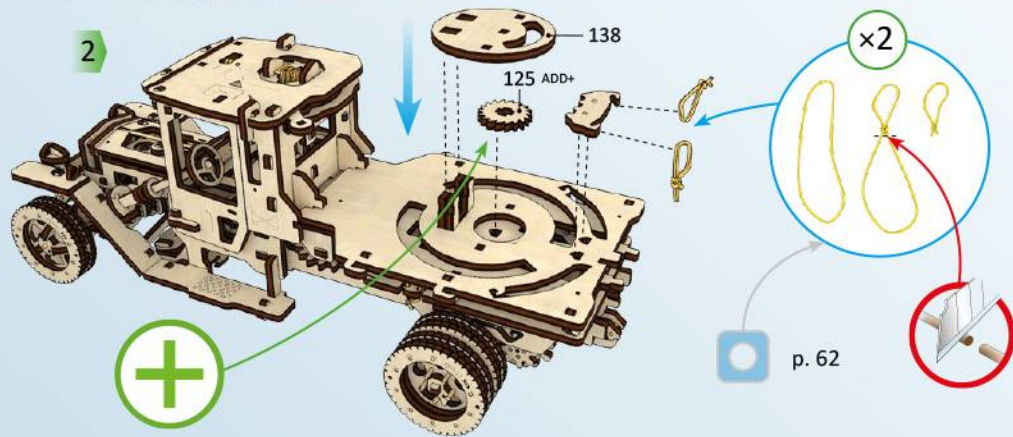
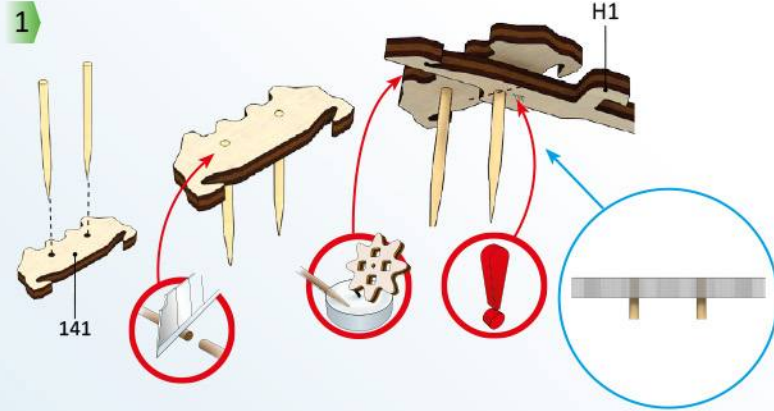
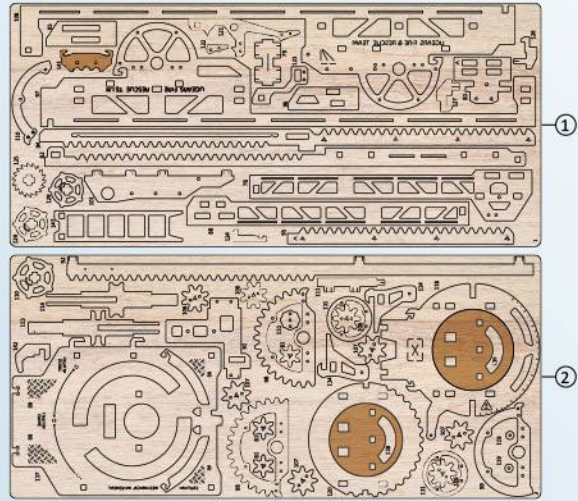

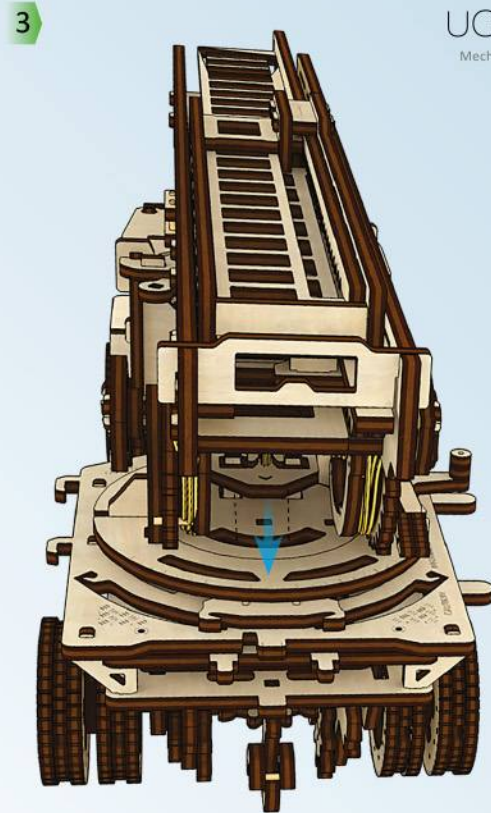
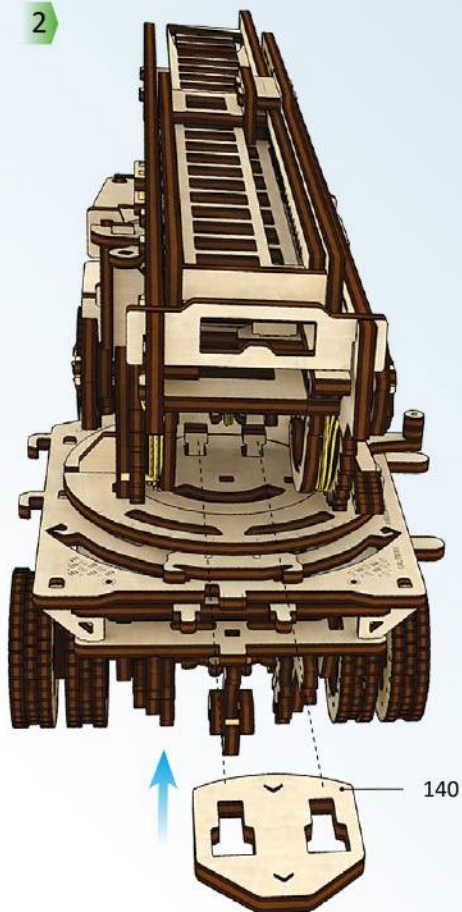
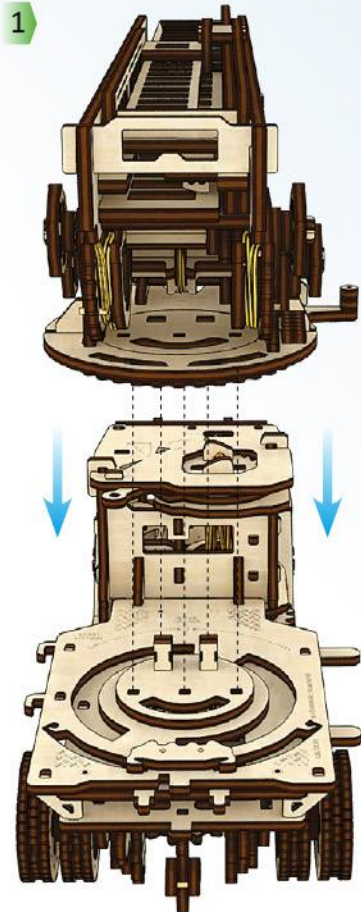
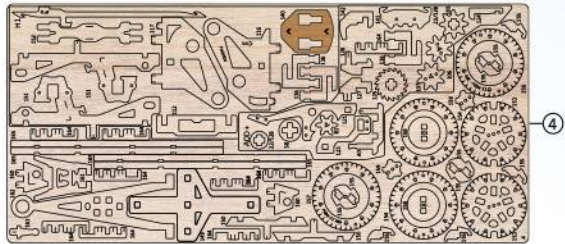

1



2



3



ENG Press the piece all the way in. **UKR** Притисніть деталь до упору. **DEU** Drücken Sie das Bauteil bis zum Anschlag ein. **FRA** Appuyez sur la pièce jusqu'en butée. **POL** Delikatnie dociskać część aż do momentu poczucia oporu. **SPA** Presione la pieza hasta que haga tope. **ITA** Premere il complemento aggiuntivo a fondo. **RUS** Прижмите деталь до упора. **JAP** しっかりと完全に押し込んでください。 **KOR** 누르고 밀어서 끼워 넣습니다. **CHI** 把消防梯压住到底。

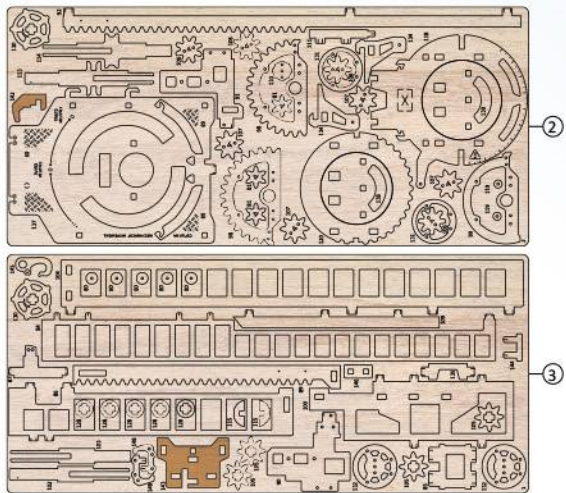

1

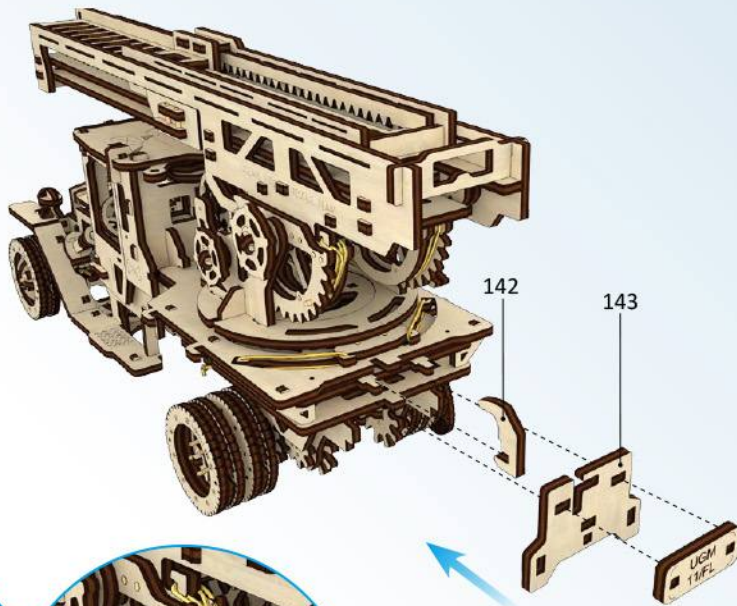

2

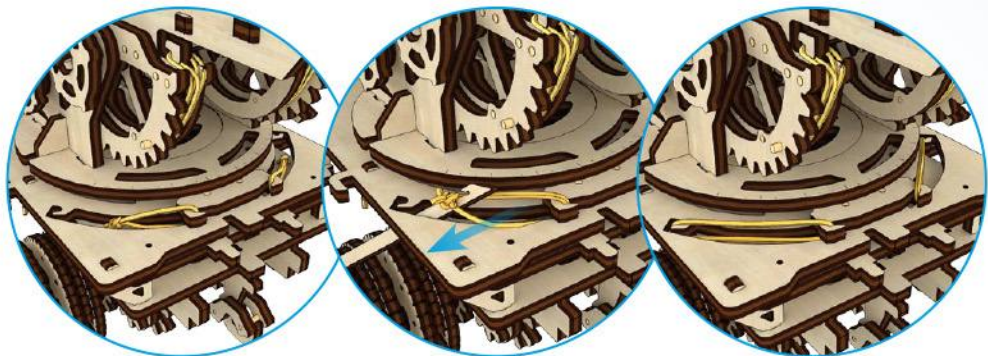
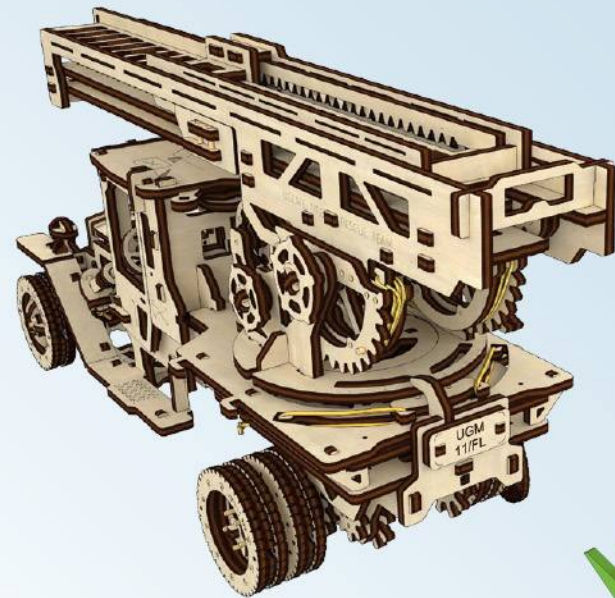

ENG The band should be tight. **UKR** Гумка повинна бути натягнута. **DEU** Das Gummi muss gespannt sein. **FRA** L'élastique doit être serré. **POL** Gumka powinna być naciągnięta. **SPA** El elástico debe ser ajustado. **ITA** L'elastico deve essere teso a sufficienza. **RUS** Резинка должна быть натянута. **JAP** ゴムバンドはしっかりとお結びください。ページ. **KOR** 고무밴드의 장력은 팽팽해야 합니다. **CHI** 橡皮筋必須拉緊。

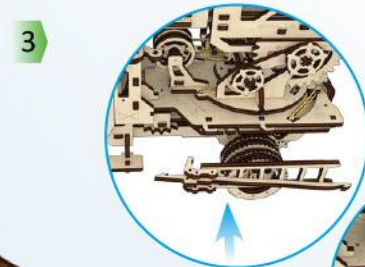
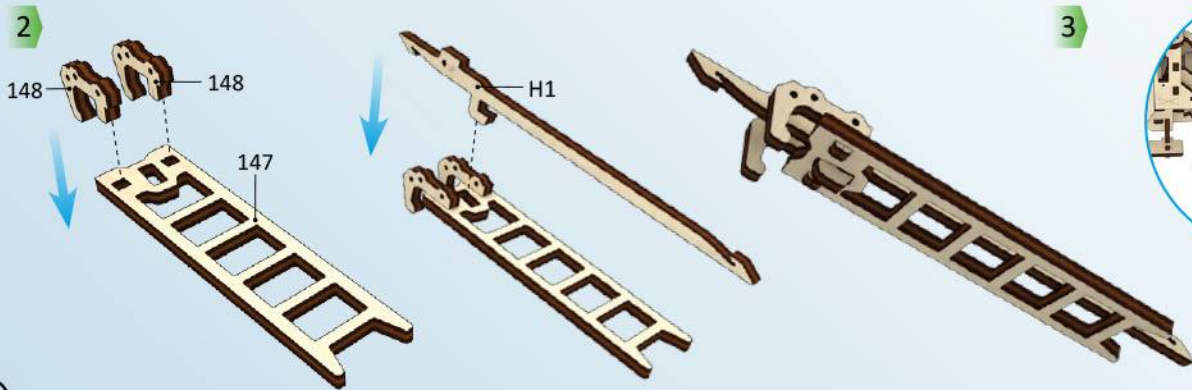
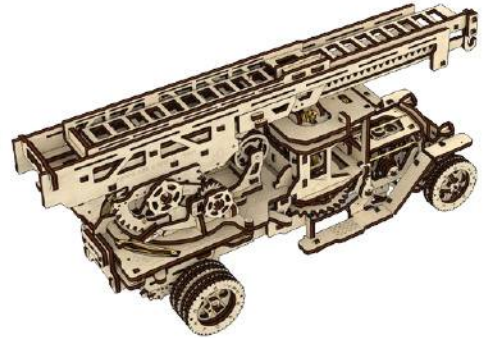
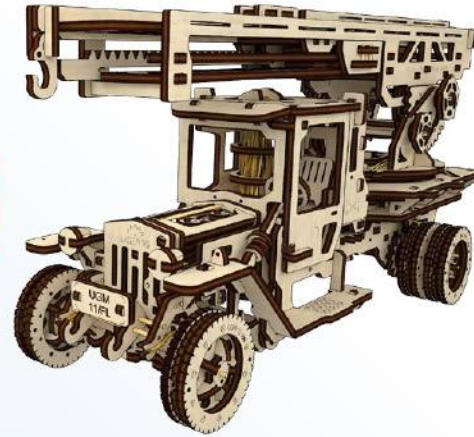
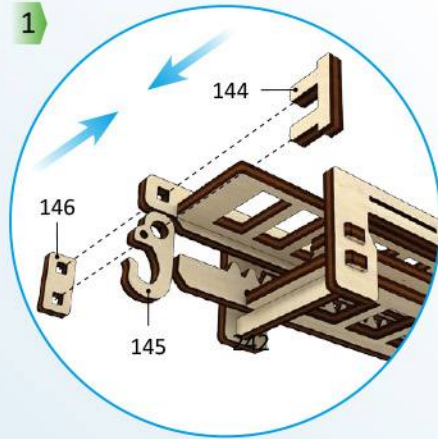
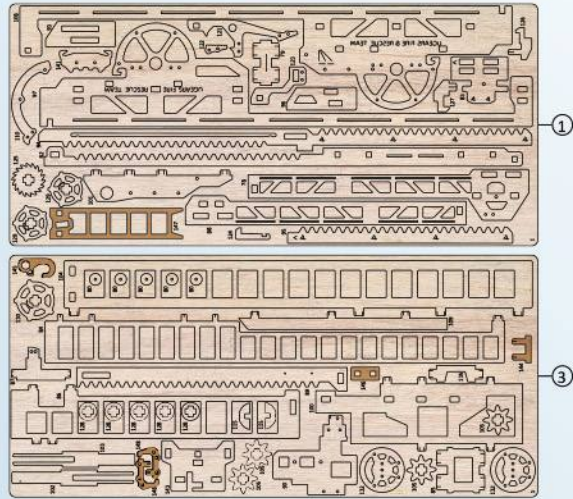

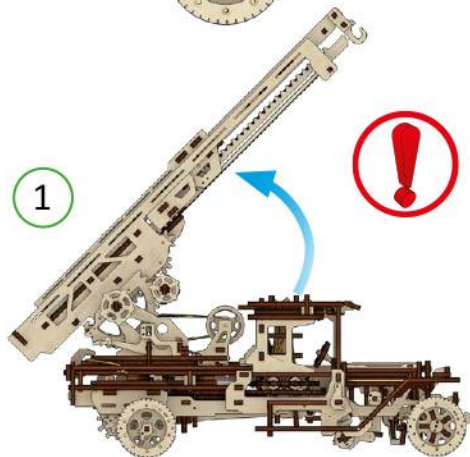
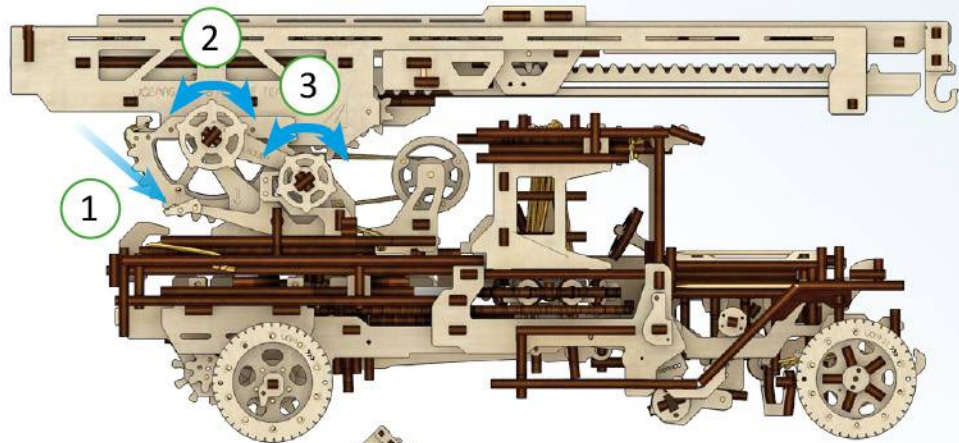

ENG Caution! The abrupt ascent of the ladder!
UKR Обережно! Різкий підйом драбини!
DEU Vorsicht! Die Leiter fährt abrupt aus!
FRA Attention à la montée rapide de l'échelle!
POL Uwaga! Drabina otwiera się gwałtownie!
SPA ¡Precaución! La brusca subida de la escalera!
ITA Attenzione! al sollevamento della scala.
RUS Осторожно! Резкий подъем лестницы!
JAP 注意！ハシゴが急に上がることもありますのでご注意ください。
KOR 주의! 사다리의 갑작스러운 상승에 주의하세요.
CHI 消防梯急剧提升。

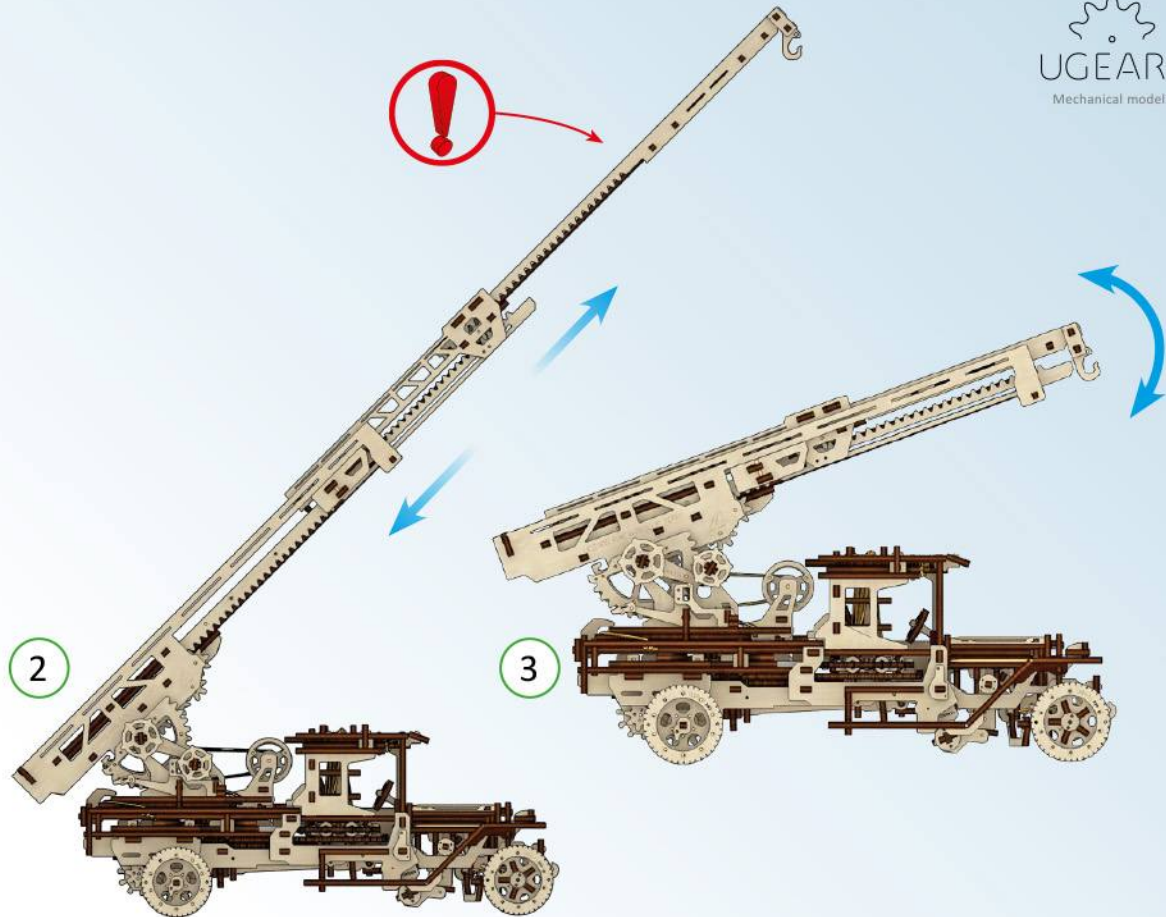

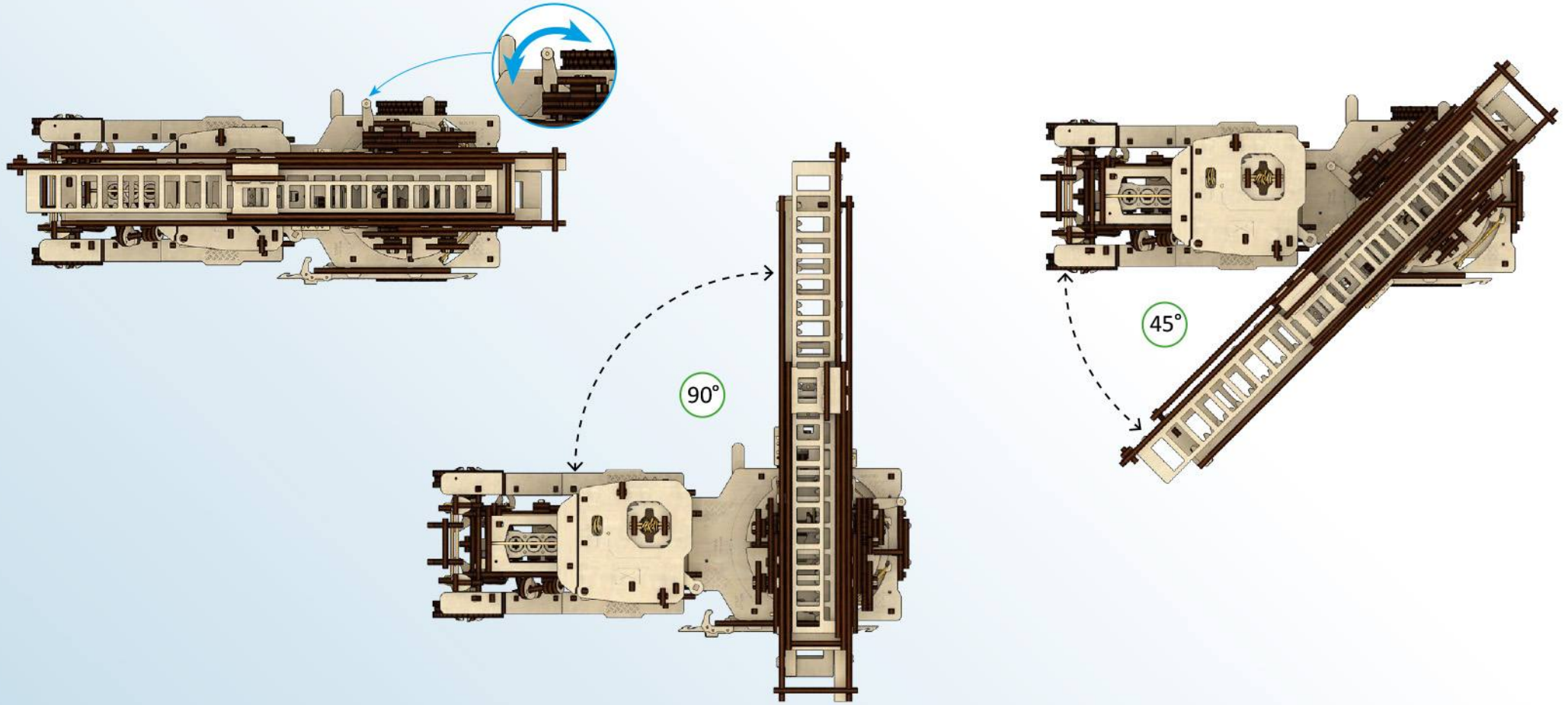





ENG Trailer. UKR Причіп. DEU Anhänger. FRA Remorque.
POL Naczepę. SPA El acoplado. ITA Rimorchio. RUS Прицеп.
JAP トレーラー. KOR 적재함. CHI 拖车



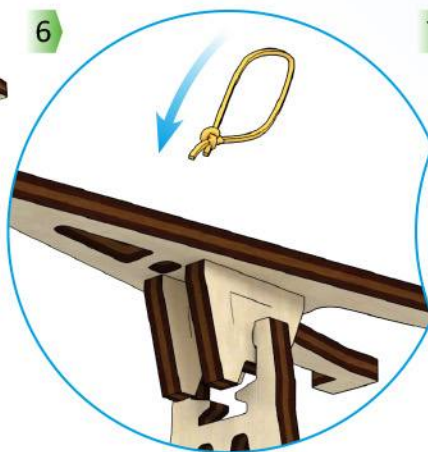
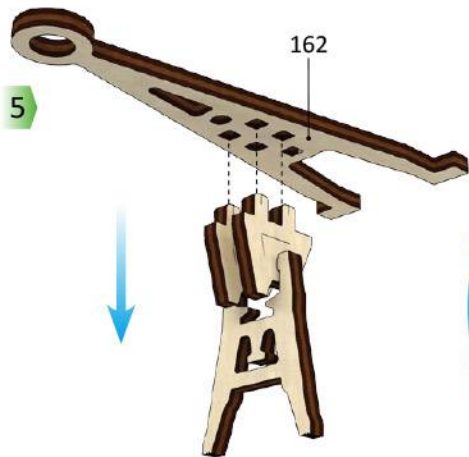
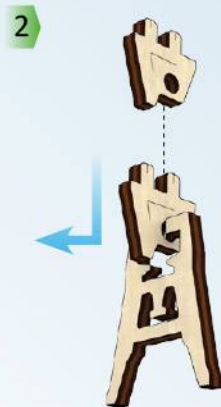
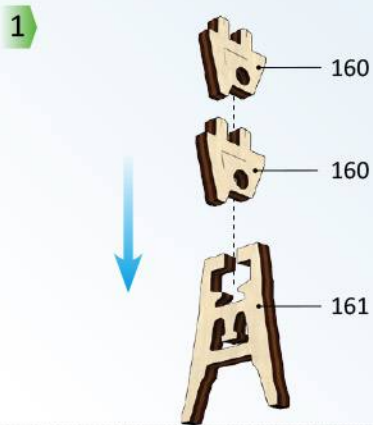
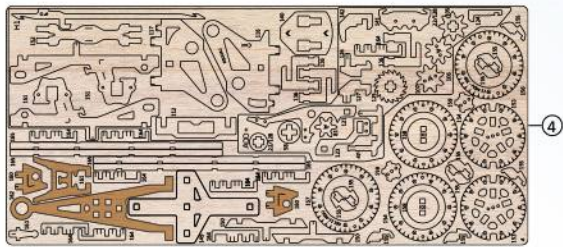

ENG The band should be tight. **UKR** Гумка повинна бути натягнута. **DEU** Das Gummi muss gespannt sein. **FRA** L'élastique doit être serré. **POL** Gumka powinna być naciągnięta. **SPA** El elástico debe ser ajustado. **ITA** L'elastico deve essere teso a sufficienza. **RUS** Резинка должна быть натянута. **JAP** ゴムバンドはしっかりと結びください。ページ. **KOR** 고무밴드의 장력은 팽팽해야 합니다. **CHI** 橡皮筋必須拉紧。

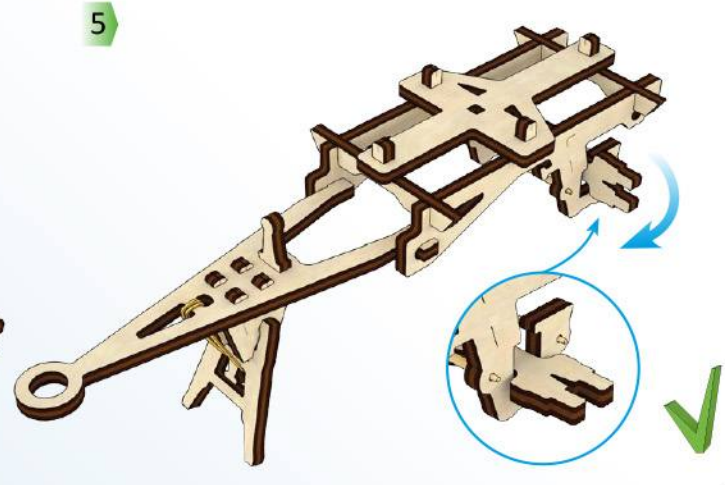
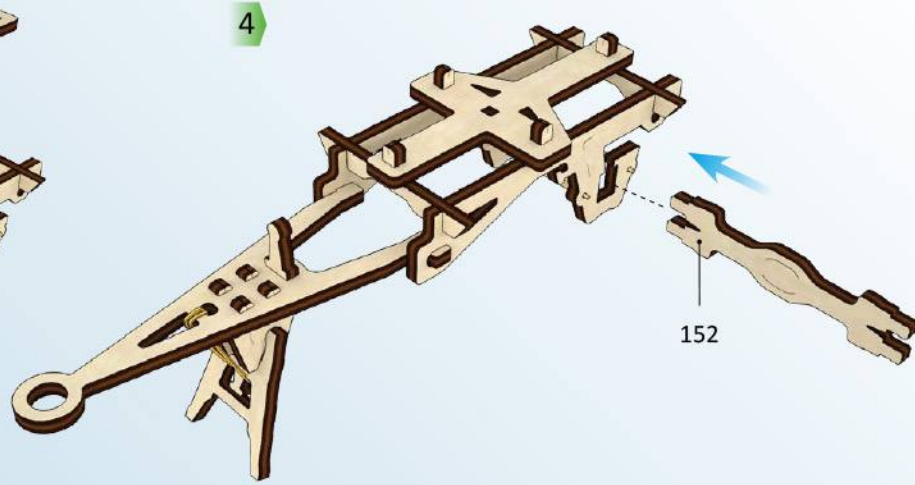
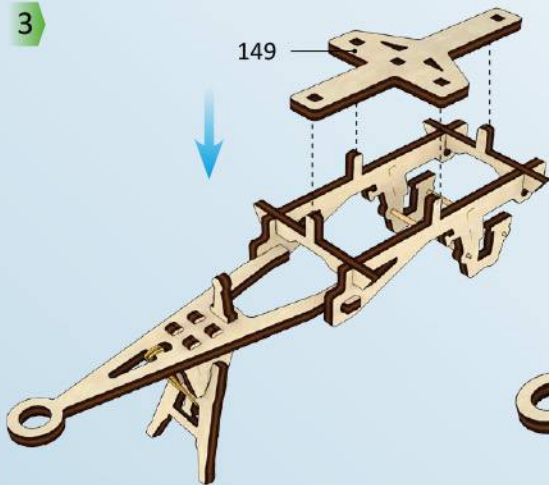
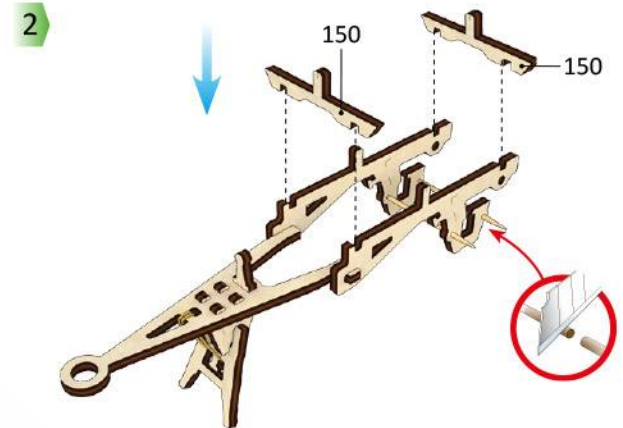
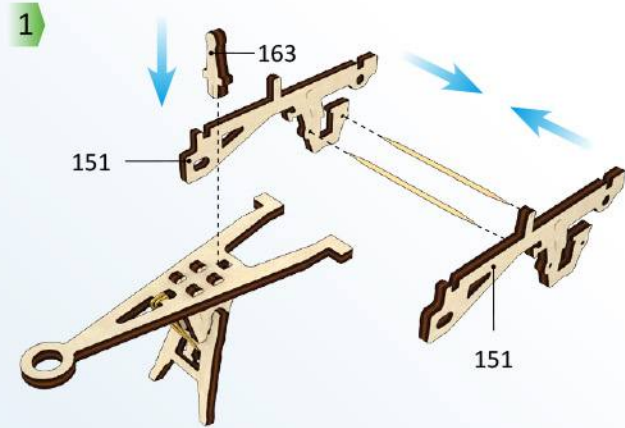
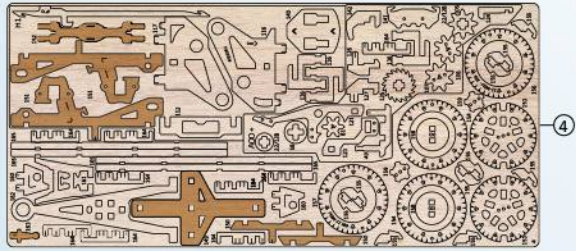

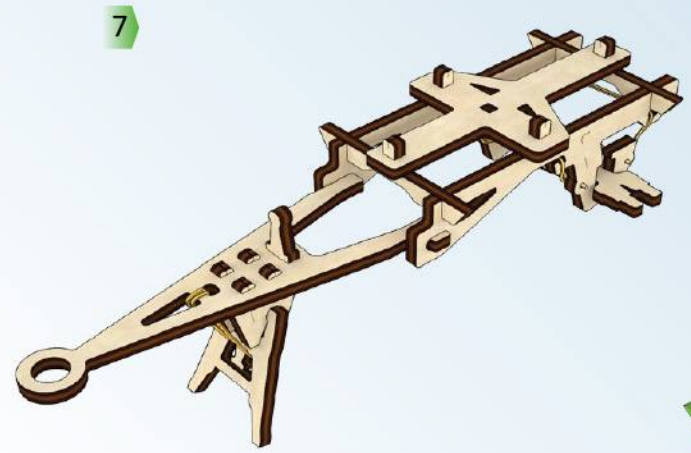
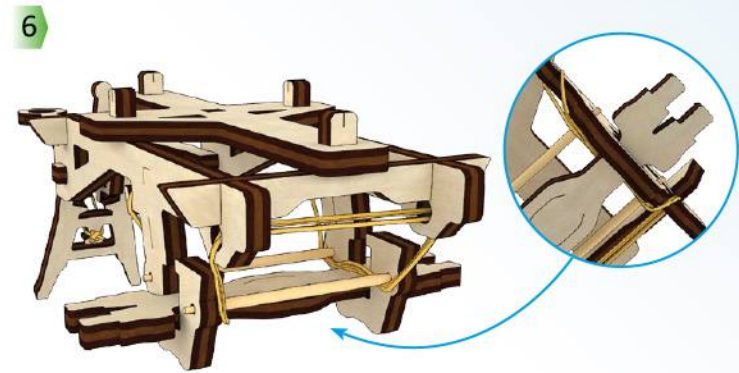
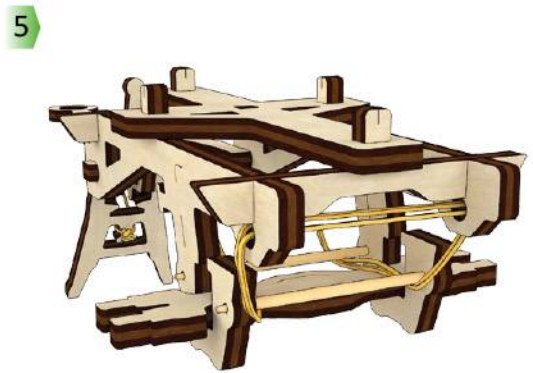
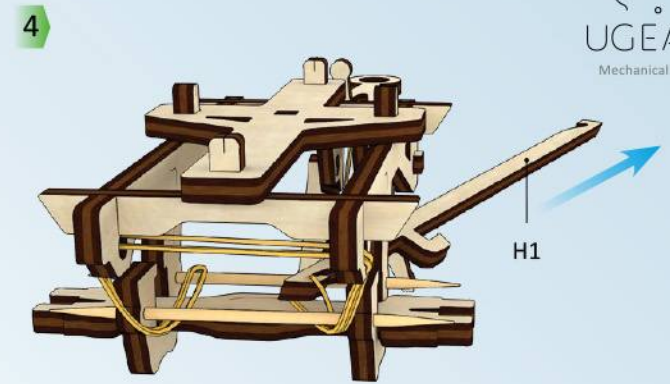
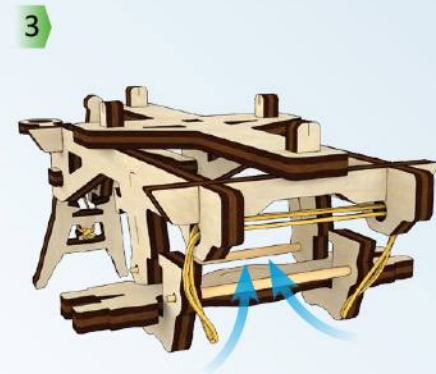
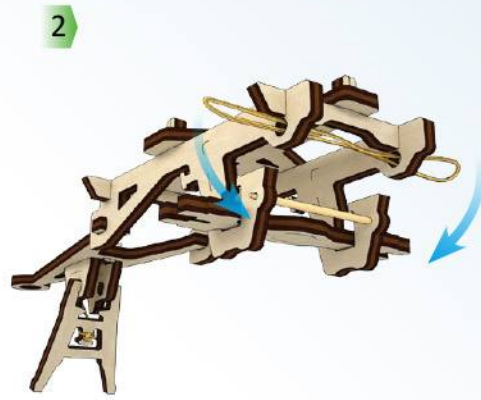
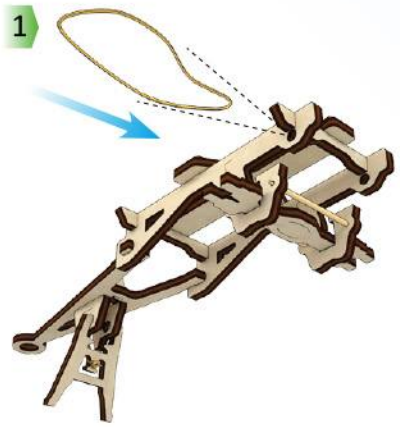

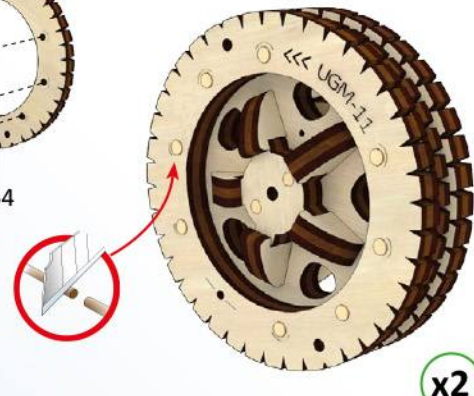
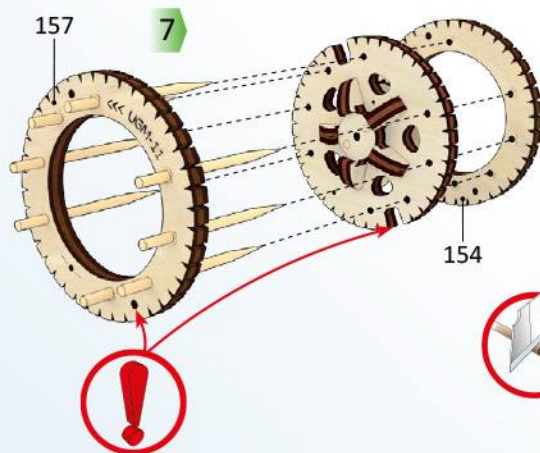
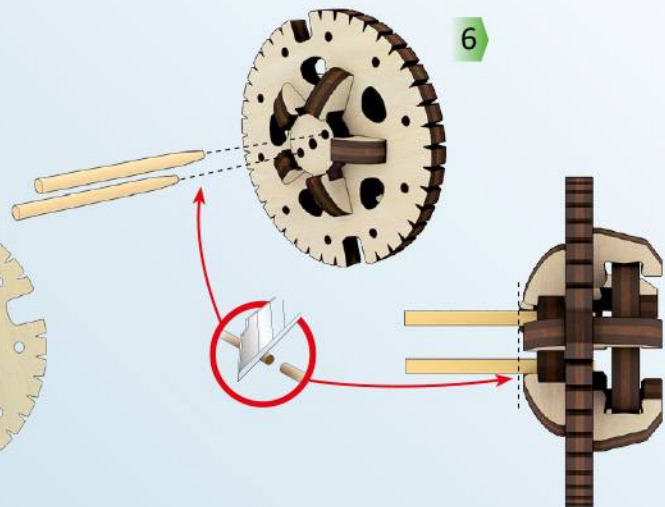
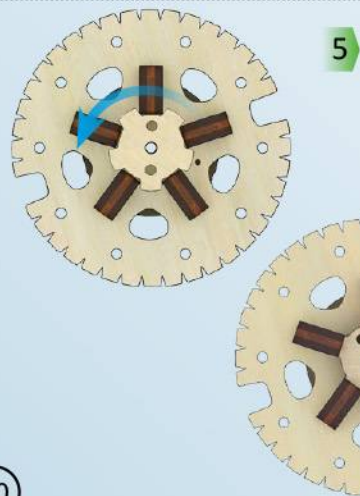
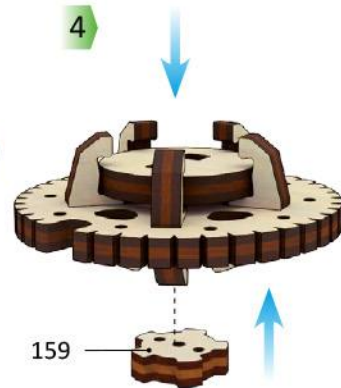
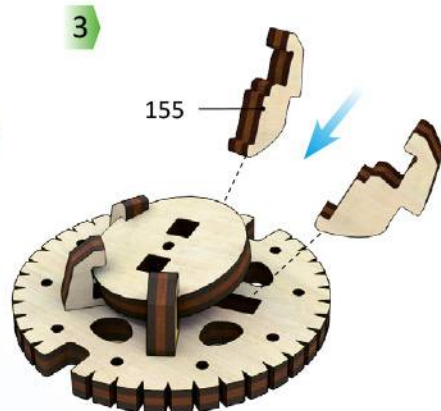
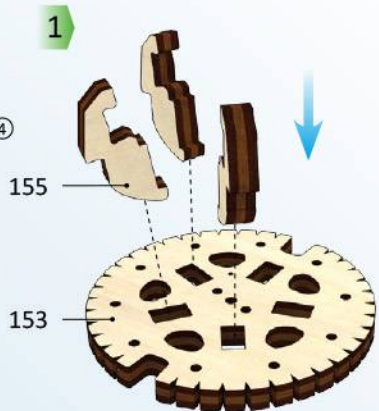
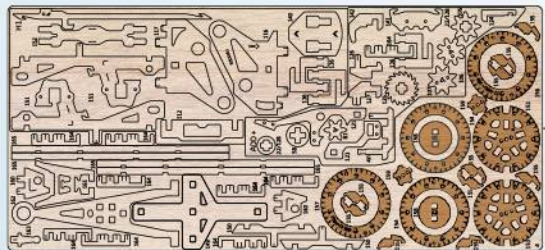

x2

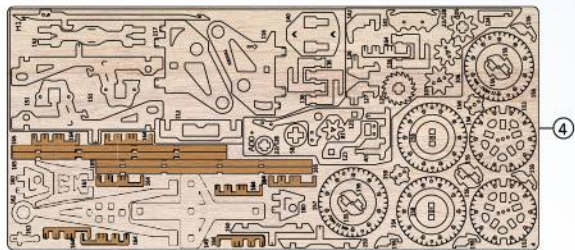

1



2

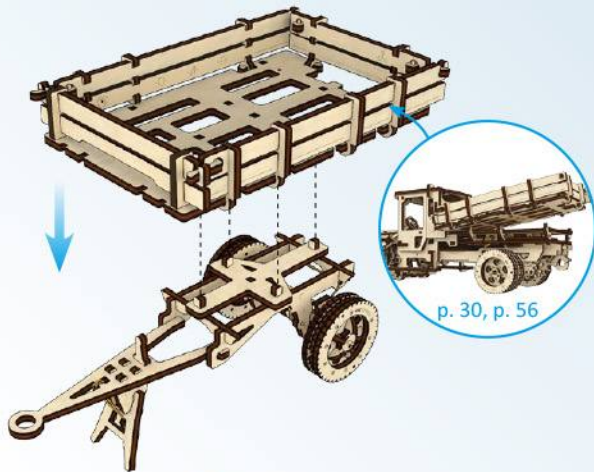

3

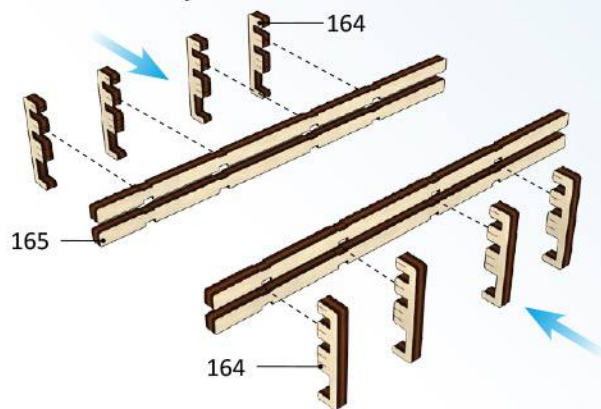

4

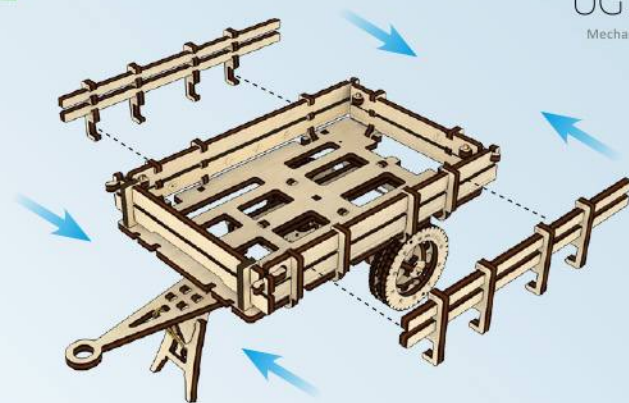

5

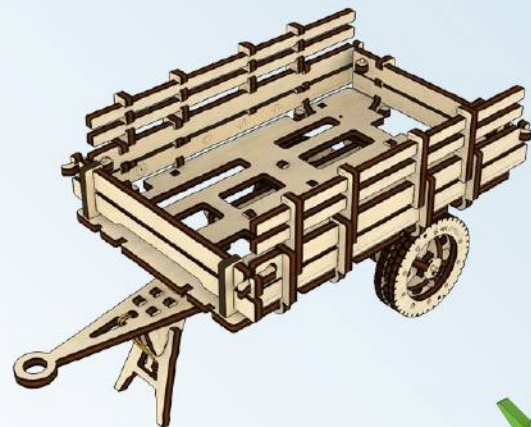



ENG Thanks for following along on this journey with us. **UKR** Дякуємо, що ви пройшли цей шлях з нами. **DEU** Vielen Dank, dass Sie diesen Weg mit uns gegangen sind. **FRA** Merci denous avoir accompagnés tout au long de ces étapes. **POL** Dziękujemy, że razem z nami pokonałeś tę drogę! **SPA** Gracias por haber recorrido el camino con nosotros. **ITA** Grazie per aver fatto uesto percorso con noi. **RUS** Спасибо, что вы прошли этот путь с нами. **JAP** UGEARSをご利用いただきありがとうございます。 **KOR** UGEARS 와 함께해 주셔서 감사합니다. **CHI** 感谢您参与有趣的模型配装过程。

ugearsmodels.com



ENG Customer support **UKR** Служба підтримки **DEU** Kundendienst
FRA Service client **POL** Wsparcie klienta **SPA** Servicio al cliente
ITA Servizio di supporto **RUS** Служба поддержки
JAP お客様窓口 **KOR** 고객지원 **CHI** 客户支持

customerservice@ugearsmodels.com