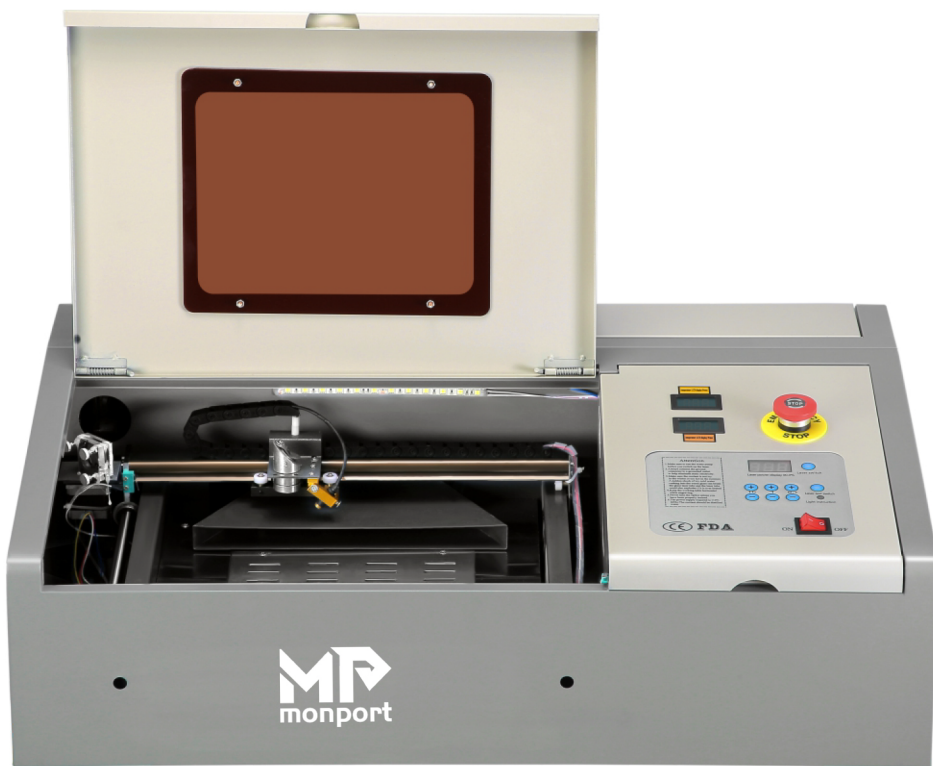


# G320-40W DESKTOP LASER ENGRAVER USER MANUAL



Read Carefully Before Use  
Keep for Future Reference

# CONTENTS

<b>Chapter 1 — Introduction</b>	3
1.1 General Information	3
1.2 Symbol Guide	4
1.3 Designated Use	4
1.4 Technical Specifications	5
1.5 Components	7
<b>Chapter 2 — Safety</b>	12
2.1 Disclaimer	12
2.2 General Safety	12
2.3 Laser Safety	13
2.4 Electrical Safety	14
2.5 Material Safety	15
<b>Chapter 3 — Installation</b>	17
3.1 Installation Overview	17
3.2 Location Selection	17
3.3 Water Cooling Installation	18
3.4 Install the Exhaust Pipe	19
3.5 Ground the Machine	19
3.6 Main Power Connection	20
3.7 Control Computer	20
3.8 Initial Testing	21
<b>Chapter 4 — Operation</b>	21
4.1 Operation Overview	21
4.2 First-Time User Guide	22
4.3 Operation Procedures	30
4.4 Principles of Engraving Various Materials	35
<b>Chapter 5 — Maintenance</b>	39
5.1 Regular Maintenance	39
5.2 Optical Path Adjustment	40
5.3 Troubleshooting	46
5.4 Disposal Instructions	47
<b>Contact Us</b>	47

# **Chapter 1 — Introduction**

## 1.1 General Information

This manual is the designated user guide for installation, setup, safe operation, and maintenance of your cabinet laser engraver. It is divided into six chapters covering general information, safety instructions, installation steps, operation instructions, maintenance procedures, and contact information.

ALL personnel involved in the installation, setup, operation, maintenance, and repair of this machine should read and understand this manual, particularly its safety instructions. Some components are extremely high voltage and/or produce powerful laser radiation. Substandard performance and longevity, property damage, and personal injury may result from not knowing and following these instructions.

Your laser engraver works by emitting a powerful laser beam from a glass tube filled with insulating carbon dioxide (CO<sub>2</sub>). The laser beam reflects off three mirrors and passes through a focus lens, after which the focused light can etch designs into certain substrates. The first mirror is fixed near the end of the laser tube, the second mirror travels along the machine's Y axis, and the third mirror is attached to the laser head that travels along the X-axis. Because some dust from the engraving process settles on the mirrors, they require frequent cleaning. They also require periodic readjustment using their attached positioning screws to maintain proper laser path alignment. A cooling water system—typically a pump or chiller—must be used with this engraver to dissipate the heat produced by the laser tube. Similarly, an exhaust system—typically either an external vent or a dedicated air purifier—must be used to remove the dust and gasses produced by the engraving process. The laser tube has an average lifespan of 500 to 1200 working hours with typical use, and the power supply has  $\geq 2000$  hours Mean Time Between Failure (MTBF). However, constantly running your laser above 70% of its maximum rated power can significantly shorten its service life. It is recommended to use 10–70% of the full rated capacity to enjoy optimal performance and longevity.

Note that this is a high-voltage device and, as a safety precaution, it is recommended to only touch its components with one hand at a time during use.

Note that the active laser is invisible to the human eye. Never operate this device while any cover is open to avoid potentially permanent injury.

Note that your machine may appear slightly different from some images in this manual.

Note also that the cooling water system and exhaust system are both absolutely essential to the safe use of this device. Never operate the engraver without both of these systems working correctly. Cooling water should always be kept clean and around room temperature, and the exhaust system should always comply with all applicable laws and regulations for the workplace and environmental air quality.

## 1.2 Symbol Guide

The following symbols are used on this machine's labeling or in this manual:



These items present a risk of severe property damage or personal injury.



These items address similarly serious concerns with regard to the laser beam.



These items address similarly serious concerns with regard to electrical components.



Protective eyewear should be worn by anyone around this machine during operation.



This product is sold in conformity with applicable EU regulations.



This product contains electrical components that should not be disposed of with regular garbage.

## 1.3 Designated Use

This machine is intended for use engraving signs and other consumer products on applicable substrates. This laser can process a wide variety of materials, including wood and cork, paper and cardboard, most plastics, glass, cloth and leather, and stone. It can also be used with some specially coated metals. Use of this system for non-designated purposes or materials is not permitted.

The system must be operated, maintained, and repaired by personnel familiar with the field of use and the dangers of the machine. The material being engraved must be deemed safe for laser exposure, including its reflectivity, conductivity, and potential for creating harmful or combustible fumes, etc.

Laser beams are dangerous. The manufacturer and/or seller bear(s) no responsibility and assume(s) no liability for any improper use of this device or any damage or injury arising from such use.

The operator is obliged to use this cabinet laser engraver only in accordance with its designated use, the other instructions in its manuals, and all applicable local and national laws and regulations.

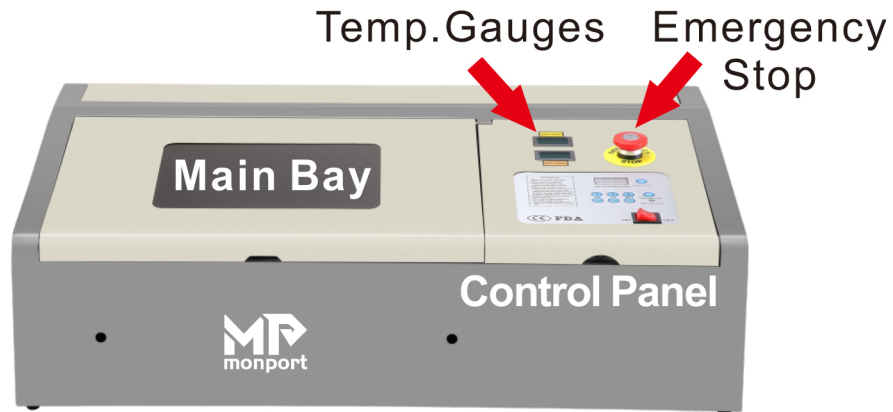
## 1.4 Technical Specifications

Model		USB-G320-40W
Color		White and Gray
Laser Type		Class 4 CO <sub>2</sub>
Tube Length		27.5 in (700mm)
Focal Lens	Diameter	0.47 in. (12 mm)
	Thickness	0.08 in. (2 mm)
	Focal Length	2 in. (50.8 mm)
Mirror	Diameter	0.79 in. (20 mm)
	Thickness	0.12 in. (3 mm)
Input Power		110V/60Hz
Power Consumption		350W
Rated Power		40W
Expected Service Life of Laser Tube		1500-2000 hours
Laser Wavelength		10640 nm
Laser Frequency		20-100 kHz
Processing Area		8" x 12" (200 x 300mm)

Maximum Engraving Speed	350mm/s (Recommended Range: 100-255mm/s)
Maximum Cutting Speed	350mm/s (Recommended Range: 1-20mm/s)
Min. Engraving Depth	0.008 in (0.2mm)
Max. Engraving Depth	0.12 in (3mm) (depends on material)
Max. Resolution	2500 dpi (1500 dpi recommended)
Min. Line Width	0.02in (0.508mm)
Precision	0.01 in (0.254mm)
Required Operating Environment	<70% Humidity 40–75°F (5–25°C)
Provided Operating Software	Shenzhouyike, LaserDRW, Winsealxp
Supported Operating Software	K40 Whisperer, Inkscape
Supported Image Formats	.wmf, .emf, .ai, .bmp, .dxf, .gif, .hpgl, .jpeg, .pdf, .plt, .png, .rd, .svg, .tiff, .tga
Graphic Operating Modes	Raster, Vector, Combined
Certification	CE, ISO9001, FDA
Net Weight	48.5 lb. (22 kg)

## 1.5 Components

### Front View



\*Your machine may appear slightly different than the image above

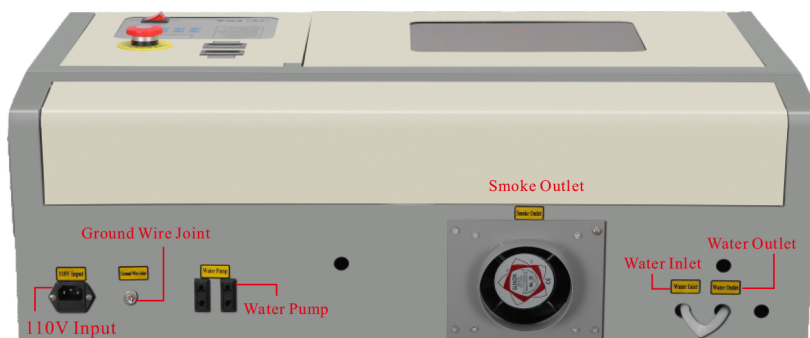
**Main Bay (Cover):** The cover provides access to the main bay for placing and retrieving materials, fixing the laser path alignment, and other maintenance.

**Control Panel:** The control panel offers hands-on control of the engraving process (See below for more details).

**Digital Temperature Gauges:** Monitor the temperature of the laser power source and cooling water (thermometers accurate to within 3 degrees).

**Emergency Stop Button:** Immediately shutdown the laser tube in case of emergency.

### Rear View



\*Your machine may appear slightly different than the image above

**Electrical Ground Connection:** Connect the ground cable to the machine here (if you do not have access to a grounded 3-prong power outlet).

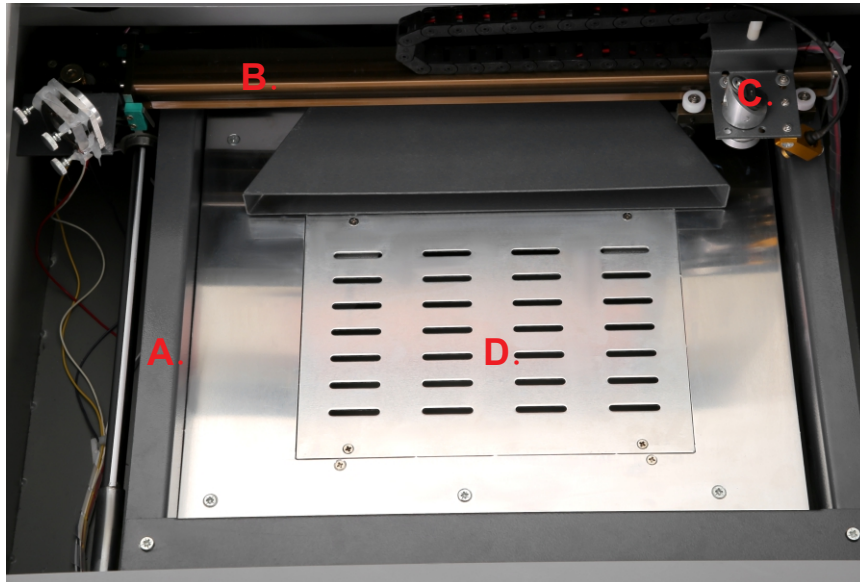
**Electrical Plug:** Connect the main power and the extended power according to the label information.

**Exhaust Fan:** Connect the exhaust duct and any external ventilation devices here.

**Water Inlet:** Connect the water-in hose of the water pump or water chiller here.

**Water Outlet:** Connect the water-out hose of the water pump or water chiller here.

### Interior Main Bay



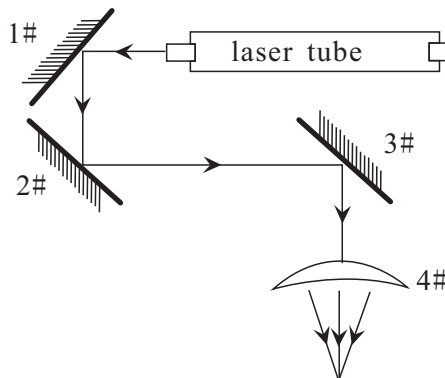
**A.Y-Axis Rail:** The Y-axis rail supports the movement of the X-axis rail up and down the workbed.

**B.X-Axis Rail:** The X-axis rail holds the 2nd mirror and supports the movement of the laser head left and right across the workbed.

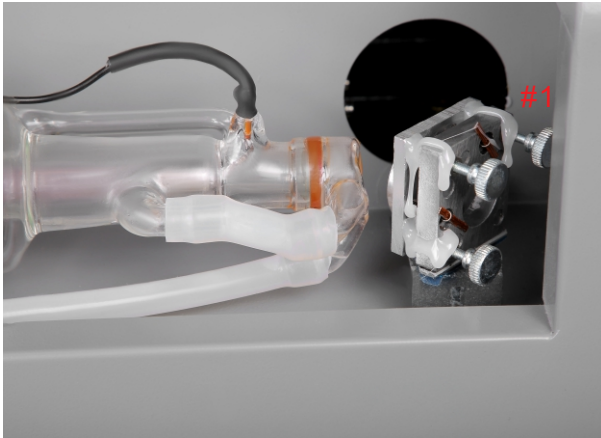
**C.Laser Head:** The laser head holds the 3rd mirror, focus lens, and Red Dot Guidance pointer.

**D.Removable Workbed:** The removable workbed is equipped with a stabilizer clamp to hold irregular-shaped objects in place and a vented level board for regular-shaped products. Workbed removal instructions are detailed in section 4.3.

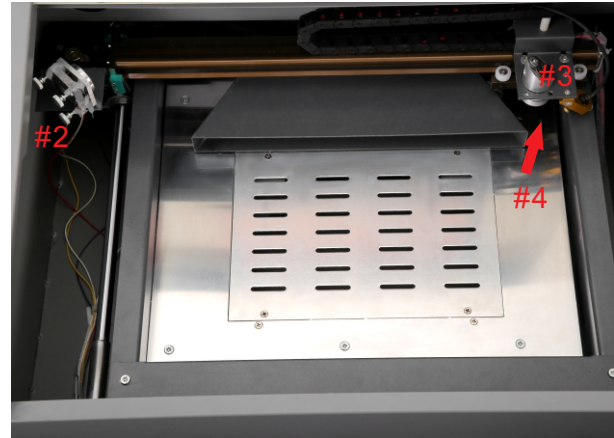
### Optical Path Diagrams







**Fig. 1-4 1st Mirror (detail).**



**Fig. 1-5. Mirrors #2-3 & Focus Lens**

The optical path is the route of the laser beam from its start at the laser tube to its final destination at the target material. The optical path consists of three reflective mirrors and one focus lens: The 1st mirror (1# in Fig. 1-4) is near the laser tube's discharge outlet in the machine's upper left corner. The 2nd mirror (2# in Fig. 1-5) is to the left of the laser head. The 3rd mirror (3#) is on top of the laser head. The focus lens (4#) is located in the lower part of the laser head.

### Accessories

In addition to any optional spare parts you ordered, your laser engraver also includes the following accessories:

A **water pump** (Fig. 1-7) is used to maintain a stream of cooling water to the laser.



**Fig. 1-7 Water Pump**

A collapsible **exhaust pipe** (Fig. 1-8) is used to vent fumes produced by processed materials during the engraving process.

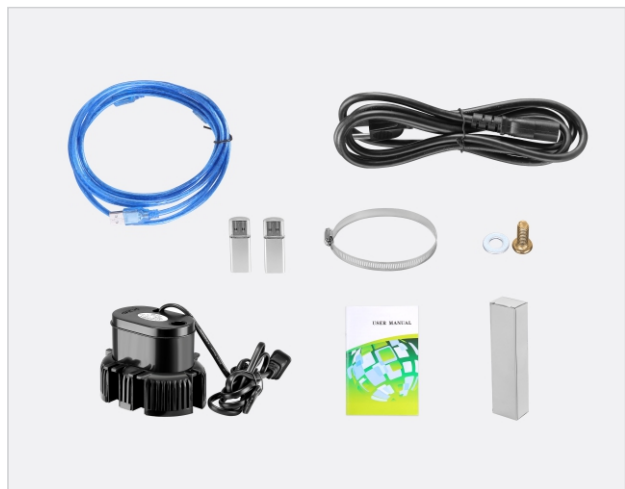


**Fig. 1-8 Collapsible Exhaust Pipe**

A bag containing various other accessories (Figures 1–9 & 1–10), including the engraver’s power cable, a USB 2.0 cable, a USB and/or a CD-ROM with software, a software safety key, a roll of double-sided tape, a 2” acrylic focus tool, silicone sealant, and this manual.



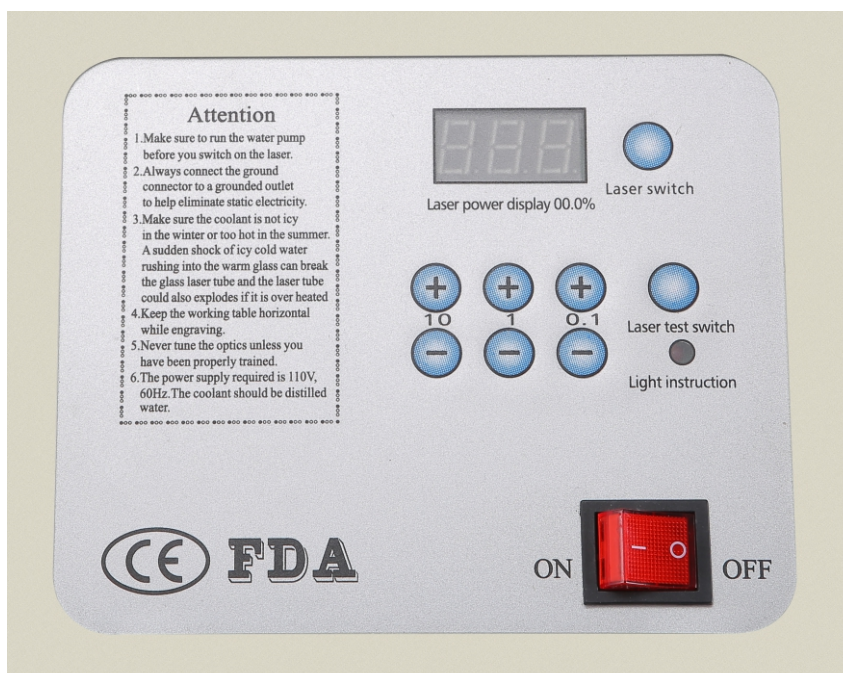
**Fig. 1–9 Accessories in Bag**



**Fig. 1–10 Accessories, Unbagged**

The control panel is used to operate the machine. Depending on which model you have, your control panel might look like either A or B.

## Control Panel



The **Type-A Control Panel** features a digital power display showing the laser's strength as a percent of its maximum output. Adjust laser power by pressing the appropriate buttons.

**On/Off Switch:** The main power switch. When switched to ON, the laser head will move to the top left corner.

**Laser Test Switch:** When the control switch is on and the cooling water is running, press this button to emit a laser beam test. The laser indicator light will come on.

**10, 1, 0.1 Buttons:** These buttons are used to adjust the laser's power in increments of 10%, 1%, and 0.1%, respectively. As expected, + increases the power by the appropriate increment. – decreases the power by the appropriate increment.

**Laser Power Display:** This displays the current power of the laser as a percent of its maximum intensity. Adjust this setting accordingly to process various materials. For most materials, an intensity between 20% and 60% is optimal. When aligning the laser beam, you should use a setting lower than 30% for safety reasons.

**Remember:** Running your laser tube above 70% power can significantly shorten the laser tube's lifetime (We recommend staying below 70% power to prolong the life of your laser tube).

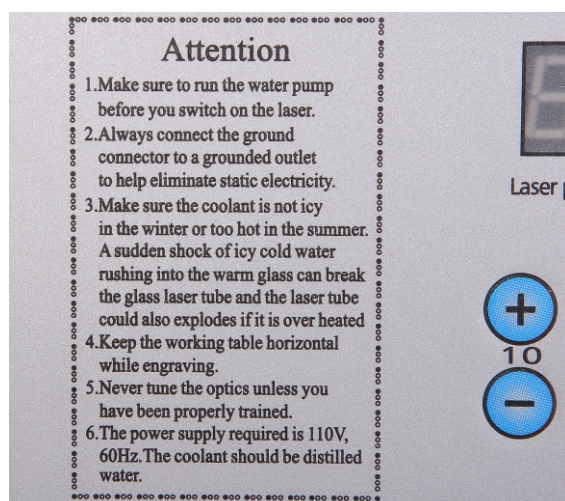
## Chapter 2 — Safety

### 2.1 Disclaimer

Your engraver may differ somewhat from those shown in this manual due to options, updates, etc. Please contact us if your engraving machine came with an outdated manual or if you have any other questions.

### 2.1 General Safety

•Your device should come with safety precaution labels such as those seen below:



If any labels are missing, illegible, or become damaged, they must be replaced.

- Use this laser engraving device only in accordance with all applicable local and national laws and regulations.
- Use this device only in accordance with this instruction manual. Ensure that this manual is included with this device if it is ever given or sold to a third party.
- **DO NOT** operate a 40W model for longer than 2 hours continuously. After 2 hours of work time, shut off and rest the machine for 30 minutes. Failure to take this precaution can result in overheating the laser tube and shortening its lifespan.
- **DO NOT** leave this device unattended during operation. Observe the device throughout operation and, if anything seems to be operating strangely, immediately cut off ALL power to the machine and contact either our customer service or your dedicated repair service. Similarly, ensure the device is FULLY turned off (including by means of the emergency stop switch) after each use.



- **DO NOT** allow minors, untrained personnel, or personnel suffering from a physical or mental impairment that would affect their ability to follow this manual and the software manual to install, operate, maintain, or repair this device.
- Any untrained personnel who might be near the device while it is in operation **MUST** be informed that it is dangerous and fully instructed on how to avoid injury during its use.
- Always keep a fire extinguisher, water hose, or other flame retardant system nearby in case of accidents. Ensure that the local fire department's phone number is clearly displayed nearby. In the case of a fire, cut electrical power before dousing the flame. Familiarize yourself with the correct range for your extinguisher before use. Take care not to use the extinguisher too close to the flame, as its high pressure can produce blowback.

## 2.1 Laser Safety

This machine uses an invisible CLASS 4 LASER, the strongest and most dangerous laser class available for public use. Used without care, it can cause serious property damage and personal injury, including but not limited to the following:



- The laser will easily burn nearby combustible materials
- Some working materials may produce radiation or harmful gasses during processing
- Direct exposure to the laser will cause bodily harm, including serious burns and irreparable eye damage

As such,

- **NEVER** leave any part of the machine open during operation. Never interfere with the laser beam, do not place any part of your body in any part of the laser path during operation, and never attempt to view the laser directly with the naked eye. When risking exposure to the laser beam, take measures to protect yourself from potentially reflected laser beams, including the use of personal protective equipment such as protective eyewear specially designed to filter the specific wavelength of your engraver's laser with an optical density (OD) of 5+.
- **DO NOT** stare or allow others to stare continuously at the laser beam during operation even when the cover is closed and/or wearing protective eyewear.
- **ONLY** use this engraver if its automatic shutoffs are working. When you first set up this engraver, and if you subsequently notice any problems, test them (see below) before undertaking any other work. Do not continue use if the shutoffs do not occur. Turn off the device and contact customer service or your repair service. Never disable these shutoffs.
- **DO NOT**, under ANY circumstance, use this laser engraver if the cooling water system is not working correctly. Always activate the cooling water system and visually confirm that water

is flowing through the entire system before turning on the laser tube. If using the provided water pump, ensure that it is placed in a tank full of cool or tepid distilled water. Do not use ice water or water above 75°F (24°C). Use a water thermometer to monitor the cooling water temperature, keeping it between 60-70°F (15-21°C). Replace heated water or add sealed bottles of frozen water to cool it while never allowing the system to run without water or allowing the water to become colder than 50°F (10°C). Immediately stop use if the water cooling system malfunctions.

- **DO NOT** leave potentially combustible, flammable, explosive, or corrosive materials nearby where they could be exposed to the direct or reflected laser beam.
- **DO NOT** use or leave sensitive EMI equipment nearby. Ensure the area around the laser is free of strong electromagnetic interference during any use.
- **ONLY** use this machine for working the materials described in the Material Safety section of this manual. The laser settings and engraving process must be properly adjusted for specific materials.
- Ensure the area is kept free of other airborne pollutants, as these might pose a similar risk of reflection, combustion, etc.
- **DO NOT** modify or disassemble the laser and do not use the laser if it has been modified or disassembled by anyone except trained and skilled professionals. Do not modify or disable this device's provided safety features. Dangerous radiation exposure and other injuries may result from the use of adjusted, modified, or otherwise incompatible equipment.

## 2.4 Electrical Safety

- **ONLY** use this device with a compatible and stable power supply with less than 5% fluctuation in its voltage.
- **DO NOT** connect other devices to the same fuse, as the laser system will require its full amperage. Do not use standard extension cords or power strips. Use only surge protectors rated over 2000J.
- **ONLY** turn on the power to this device when it is well-grounded, either via a firm connection to a 3-prong outlet or via a dedicated grounding cable firmly connected to the ground cable connection on the machine's rear. Do not use an ungrounded 3 to 2 prong adapter. The device's grounding should be checked regularly for any damage to the line or loose connections.
- The area around this laser engraving device should be kept dry, well ventilated, and environmentally controlled to keep the ambient temperature between 40–75°F (5–25°C). The ambient humidity should not exceed 70%.



- Do not handle the water pump (or the water in which it is submerged) while it is attached to its power supply. Place it in water before connecting it to power and disconnect it from power before removing it.
- Adjustment, maintenance, and repair of the electrical components of this device must be made **ONLY** by trained and skilled professionals to avoid fires and other malfunctions, including potential radiation exposure from damage to the laser components. Because specialized techniques are required to test the electrical components of this marking system, such testing is recommended only by the manufacturer, seller, or repair service.
- Unless otherwise specified, **ONLY** undertake adjustment, maintenance, and repair of the device when it is turned off and disconnected from its power supply.

## 2.5 Material Safety

- Users of this laser engraving machine are responsible for confirming that processed materials can withstand the heat of a class 4 laser and will not produce any emissions or byproducts either harmful to people nearby or in violation of local or national laws or regulations. In particular, do not use this device to process polyvinyl chloride (PVC), Teflon, or other halogen-containing materials under any circumstances.
- Users of this laser engraver are responsible for ensuring that every person present during operation has sufficient PPE to avoid injury from the emissions and byproducts of the materials being processed. In addition to the protective laser eyewear described above, this may require goggles, masks or respirators, gloves, and other protective outer clothing.
- **DO NOT** ever use this laser engraver under any circumstances if the exhaust system is not working properly. Always ensure that the exhaust fan can remove the dust and gas produced by the engraving process in accordance with all applicable local and national laws and regulations. Immediately stop use if the exhaust fan or vent pipe malfunctions.
- Users must exercise special caution when working with conductive materials as the buildup of their dust and ambient particles may damage electrical components, cause short circuits, or produce other effects, including reflected laser radiation.

**This machine can be safely used with the following materials:**

### **Plastics**

- Acrylonitrile Butadiene Styrene (ABS)
- Nylon (Polyamide, PA, etc.)
- Polyethylene (PE)
- High-Density Polyethylene (HDPE, PEHD, etc.)
- Biaxially-Oriented Polyethylene Terephthalate (BoPET, Mylar, Polyester, etc.)
- Polyethylene Terephthalate Glycol (PETG, PET-G, etc.)

- Polyimide (PI, Kapton, etc.)
- Polymethyl Methacrylate (PMMA, Acrylic, Plexiglass, Lucite, etc.)
- Polyoxymethylene (POM, Acetal, Delrin, etc.)
- Polypropylene (PP, etc.)
- Styrene

### **Other**

- Cardboard
- Ceramics, including Dishes, Tile, etc.
- Glass
- Leather
- Paper & Paperboard
- Rubber
- Stone, including Marble, Granite, etc.
- Textiles, including Cotton, Suede, Felt, Hemp, etc.
- Wood, including Cork, MDF, Plywood, Balsa, Birch, Cherry, Oak, Poplar, etc. See §4.3 for the recommended parameters for the most commonly engraved materials.

**This machine CANNOT be used with the following materials or with any materials which include them:**

- Artificial Leather containing Hexavalent Chromium (Cr[VI]), due to its toxic fumes
- Astatine, due to its toxic fumes
- Beryllium Oxide, due to its toxic fumes
- Bromine, due to its toxic fumes
- Chlorine, including Polyvinyl Butyral (PVB) and Polyvinyl Chloride (PVC, Vinyl, Cintra, etc.), due to its toxic fumes
- Fluorine, including Polytetrafluoroethylene (Teflon, PTFE, etc.), due to its toxic fumes
- Iodine, due to its toxic fumes
- Metals, due to their conductivity and reflectivity
- Phenolic Resins, including various forms of Epoxy, due to their toxic fumes
- Polycarbonate (PC, Lexan, etc.), due to its toxic fumes

For all other materials, if you are unsure about its safety or laserability with this device, check the specific Safety Data Sheet (SDS) or contact our support department for further guidance.



## **Chapter 3 — Installation**

### **3.1 Installation Overview**

A complete working system is composed of the laser engraving machine, its exhaust system, water cooling system, and a USB cable for a computer or flash drive connection. Users can also configure optional accessories to suit their needs.

Keep the packing box. You may need it in case of a return.

Use only the hardware, wiring, and power sources that came with or are compatible with this device. Installing equipment that your device is not designed to work with can lead to poor performance, shortened service time, increased maintenance costs, property damage, and personal injury.

Please note the specific requirements of your system's installation. Every customer must understand these notes before installation to execute a proper setup and achieve safe laser performance. If you have any installation questions or problems, contact our technicians and customer support team.

Any auxiliary equipment must be adjusted to the base machine. Queries may be directed to the dealer or manufacturer of such equipment.

### **3.2 Location Selection**


Prior to assembling your laser engraver, select an appropriate location for its use.


Be sure that it meets all of the requirements discussed in the Safety Information above.

The location should be stable, level, dry, and climate-controlled to ensure an ambient temperature of 40–75°F (5–25°C) and an ambient humidity of under 70%. In particular, the temperature and humidity together should not be close to the dew point. It is also advisable to use a windowless room or to use blinds and/or curtains to avoid exposure to the potential additional heat of direct sunlight. The location should be free of dust and other airborne pollutants and well ventilated enough to process any fumes produced by the engraving process in accordance with all applicable laws and regulations. Depending on the materials to be processed, this may require the construction of a dedicated ventilation system. It should be kept away from children, sensitive EMI devices, and combustible, flammable, explosive, or corrosive materials. The power cord should be plugged into a compatible and stable power source via a grounded 3-prong outlet. No other item should be drawing current from the same fuse. There should be fire-fighting equipment nearby, and the local fire department's phone number should be clearly displayed.

It is highly recommended to have an extra work table nearby in order to avoid placing objects on or directly adjacent to the machine, which could become a fire or laser hazard.

### 3.3 Water Cooling Installation

 The provided water pump is essential to your engraver's performance and longevity. When this laser works without a properly maintained cooling system, its glass tube **WILL** explode from excess heat.

 **NEVER** touch or adjust your engraver's water supply while the pump is connected to its power supply.

To install your pump, fill a dedicated tank with distilled water. Using deionized or tap water will gradually degrade the quality of your engraver and may even cause dangerous mineral buildup in the cooling system. **NEVER** use antifreeze for the same reason.

Connect the two hoses that came with your engraver to the water inlet (marked "Water IN") and water outlet (marked "Water OUT") on the back of your engraver. Attach the other end of the inlet tube directly to your pump and completely submerge the pump in your water tank. Place the outlet tube into the tank in such a way that the returning water flows into the tank without splashing or other problems.



**Fig. 2-1 - The Cooling Water System**

Connect the water pump to its power supply. For best results, use a power outlet on a separate fuse from the engraver itself. If no such outlet is available, the pump can also be plugged into a dedicated socket located on the side of the engraving cabinet. Once the pump is plugged in, water should begin to run through your machine and back into your tank. **ALWAYS** obtain visual confirmation that the water is flowing through the laser tube before starting your laser.

**NEVER** allow the water in the tank to become too hot to cool the laser. Heat damage can occur quickly and severely shorten the life of the laser tube. Periodically check the water's temperature on the built-in digital display, ensuring it stays between 60-70°F (15-21°C). If the water begins to reach 75°F (24°C), replace it with cooler water. Either replace it in stages or turn off the laser during this process: never allow the laser to operate without a constant flow of cooling water. It is also possible to add sealed bottles of frozen water to your tank to keep the water cool but never allow the water to become ice cold itself, as this could shatter the heated glass CO<sub>2</sub> tube as well.

As an alternative to manually adjusting the water in your tank, you may also use an industrial water chiller to supply temperature-controlled water to your machine. We recommend the CW-3000 9L INDUSTRIAL WATER COOLING SYSTEM (not included). Follow its separate manual and plug it into a separate fuse from the engraver itself.

Periodically check the laser power source's temperature on the built-in digital display, ensuring it does not exceed 100°F (38°C). If the laser power source does rise above this temperature, shut down the unit and let it rest for at least 30 minutes (or longer depending on ambient temperature).

#### **Helpful Tips:**

Before starting up the laser power, always ensure the water tank is full of distilled water, and obtain visual confirmation of water flow through the laser tube.

#### **Outdoor Locations/Freezing Temperatures:**

We do not recommend using coolant or antifreeze in place of cooling water, as it can leave behind corrosive residues and solidify inside your hoses and laser tube, causing laser tube damage.

### **3.4 Install the Exhaust Pipe**

Install the exhaust pipe to the fan, as shown in Fig. 2-2 below. The pipe can be expanded to a full length of about 5 feet (1.5 m). The other end of the pipe should be connected to a dedicated purifier or placed out a window. We recommend that you attach the venting hose to a filtration system but, if this is not possible, place the hose so that it can vent outside the building. Never operate the machine in a closed room, as the smoke and fumes can irritate your eyes, nose, mouth, and lungs.



**Outdoor Locations/Freezing Temperatures:**

### **3.5 Ground the Machine**

Your laser engraver uses a class 4 laser. As mentioned in the Safety Instructions, this type of laser is high voltage and potentially dangerous, so users must securely ground it during use to

prevent the buildup of static electricity. A grounded 3-prong power outlet will provide a sufficient grounding connection. If you cannot use a grounded 3-prong power outlet, you must set up a separate ground wire with safe line-to-ground resistance under  $5\Omega$ . Fig. 2-3 below shows the location on the back of the engraver where the grounding cable should be connected. Fig. 2-4 shows a diagram of the necessary setup.



Fig. 2-3

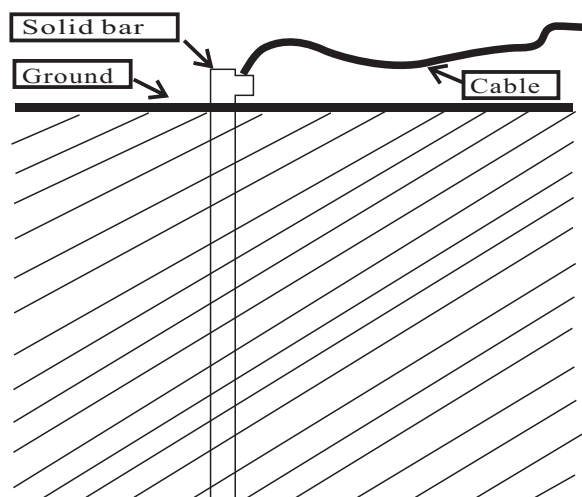


Fig. 2-4



**WARNING: Poor grounding will cause equipment failures and create a serious electrical shock hazard! We do not assume any responsibility or obligation for machine damages, accidents, or injuries caused by bad grounding connections.**

### 3.6 Main Power Connection

Confirm that the labeling beside the connection socket on the machine matches your power supply. Connect one end of the main cable to the connection socket and the other end to a grounded outlet. Under NO circumstances should you switch on the device if the voltages do not correspond.

Fluctuation along the line should be less than 5%. If this is exceeded, the fuses will blow. They are located in the connection socket and are accessible from the exterior. Similarly, do not connect this device to standard extension cords or power strips. Connect it directly to a grounded outlet or use a surge protector rated over 2000J.

### 3.7 Control Computer

See your software manual for details on the requirements for the control computer. The control computer can be connected using the provided USB cable (via the port marked "PC"). If the control computer is directly connected to the engraver, it should not be placed more than 15 feet (4.5 m) away in order to avoid possible interference to the signal on its line. Familiarize yourself

with the software's image design features and laser control settings before using it to operate the laser.

## 3.8 Initial Testing

### Emergency Shutoff

Because of the danger posed by class 4 lasers, this engraver includes a large and easy-to-reach emergency stop button near the control panel. Press it down to stop the laser tube instantly.




When your engraver arrives, its e-stop should be pressed down and must be pulled up to allow the laser to function. You should test that it works properly before conducting ANY other work with your machine. Start the water cooling system, place a piece of laserable scrap material on the workbed, close the cover, and press PULSE to fire the laser. Hit the emergency stop button and observe whether the laser stops instantly. If the laser continues to fire, the emergency stop is not working and must be replaced before the engraver can be used. Turn off the machine and contact customer service.

### Laser Path Calibration

Although our factory calibrates your entire system during assembly, it is possible for the laser tube, the focus lens, and/or one or more of the mirrors to be jostled out of alignment during shipment. As such, it is recommended that you perform an optical alignment test as part of setting up your machine. See the Maintenance section below for step-by-step guidance.

## Chapter 4 — Operation

### 4.1 Operation Overview

 Operate this laser marking machine only in accordance with all the instructions provided in this manual. Failure to follow the proper guidelines detailed here can result in property damage and personal injury. This section will address only some of the options and features provided by

the operation software. Before beginning to use the machine, make sure that you have read this entire manual (particularly the Safety Information above), the separate software manual, and all warnings provided on the machine itself.

## 4.1 First-Time User Guide

Read below for detailed instructions on how to connect your machine to your PC, create a simple design using LaserDRW, and execute your first engraving. For general software installation and instructions, see your separate software manual.

### Step 1: Prepare Your Machine

Before use, check that all safety systems are working correctly:

- The unit is placed on a level surface free from flammable materials in a safe location, as detailed in section 3.2.
- The water cooling system is functioning suitably, as detailed in section 3.3.
- Exhaust vents are set up properly, as detailed in 3.4.
- Grounding and power connections are secure, as detailed in sections 3.5 & 3.6.

### Step 2: Prepare Your Copy of LaserDRW

If you have not already done so, install LaserDRW, the software program provided on the U-disk or flash drive in your accessories bag. Once installed, connect the machine to your PC using the supplied USB cable (Fig. 3-3). Connect the provided USB as well (Fig. 3-4). Once you have it connected, open LaserDRW.



Fig. 3-3

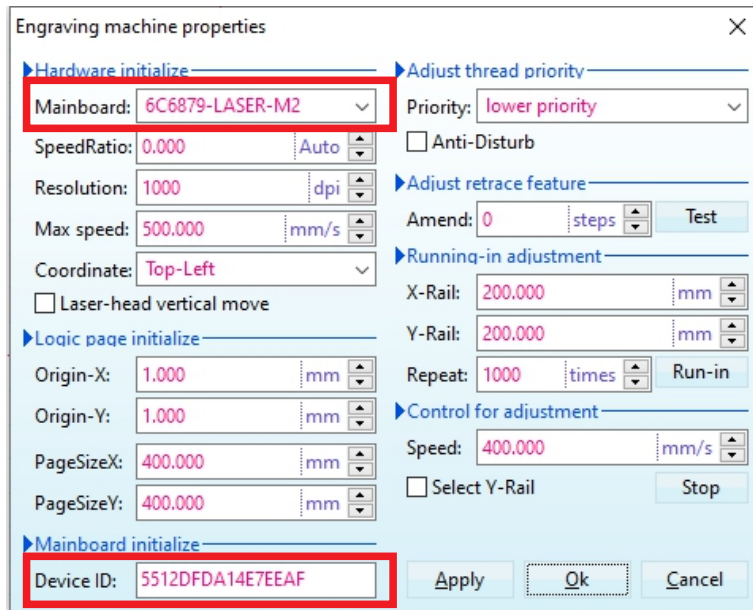


Fig. 3-4

Once you have LaserDRW open, go to the top toolbar and click on “Engrave,” then “Device initialize.”



**Fig. 3-5 - The LaserDRW Tool Bar**

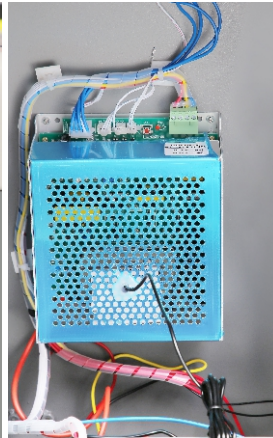


**Fig. 3-6**

In the “Engraving machine properties” menu (Fig. 3-6), make sure that your Mainboard and Device ID match your machine. You can find your machine’s Mainboard and Device ID on its motherboard (Fig. 3-9 & 3-10). To access the motherboard, first, make sure you have the machine turned off and then unscrew the control lid (Fig. 3-7).



**Fig. 3-7**



**Fig. 3-8**



**Fig. 3-9**

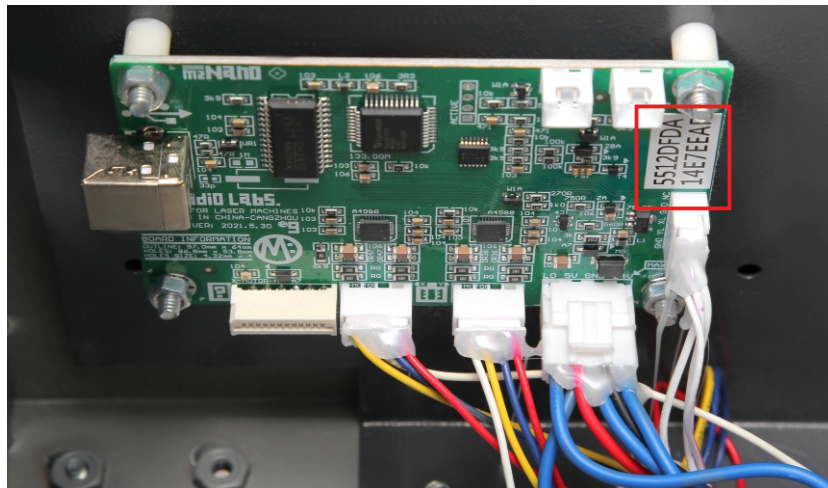


Fig. 3-10

Select your Model Number and type in your Device ID accordingly (Fig. 3-11).

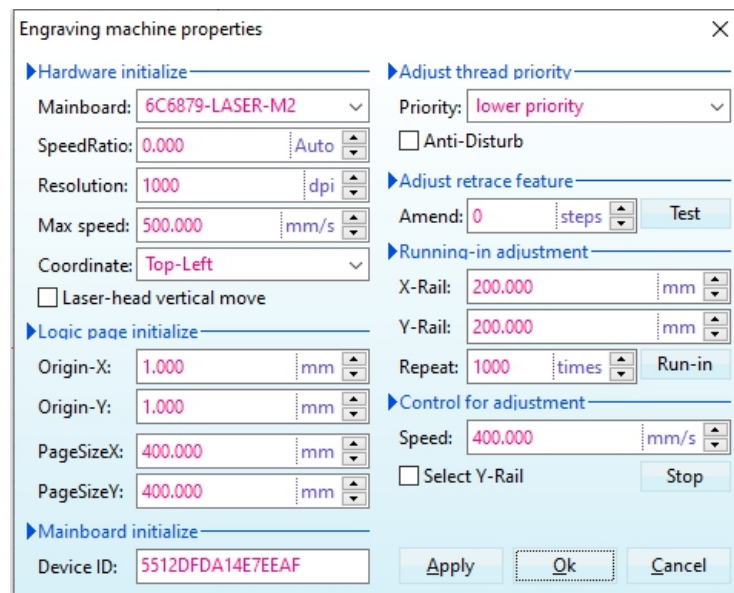


Fig. 3-11

Press “Apply” and then “Ok.” You may be asked to restart the program. If so, close and reopen the program. Close and refasten the cover lid.

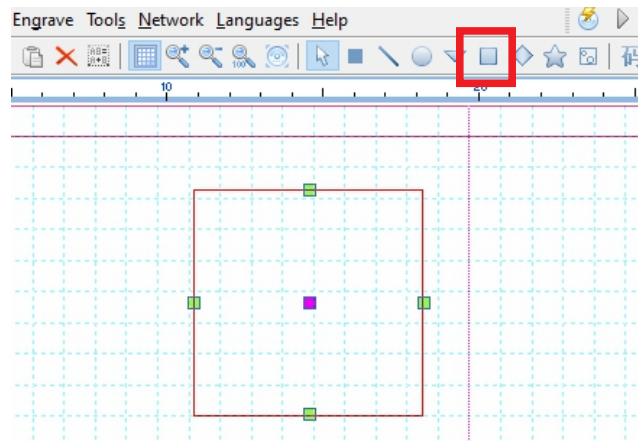
### Step 3: Turn On Your Machine

Turn on your machine. You will now be able to control the machine with your PC.

### Step 4: Test Connectivity

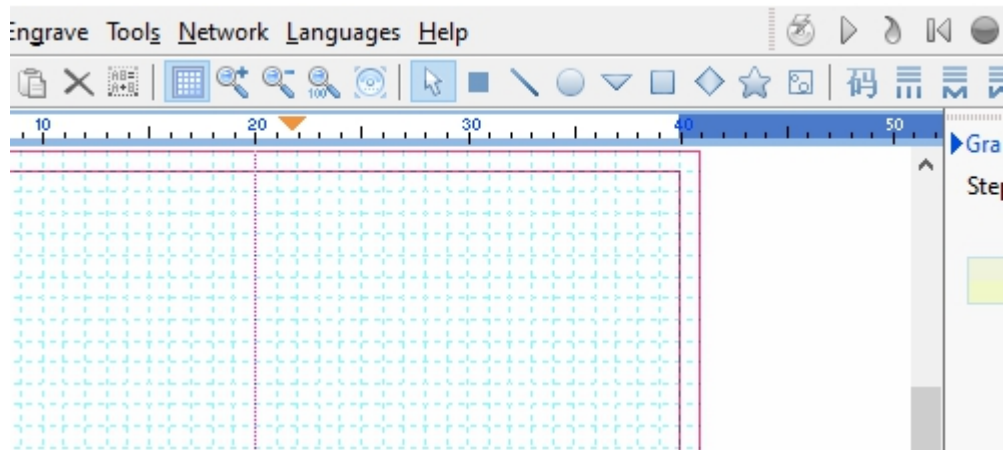
To test out connectivity, use the Square Tool to draw a small rectangle (Fig. 3-12). When you click on the square again, it should be outlined in red. This means it will be processed.





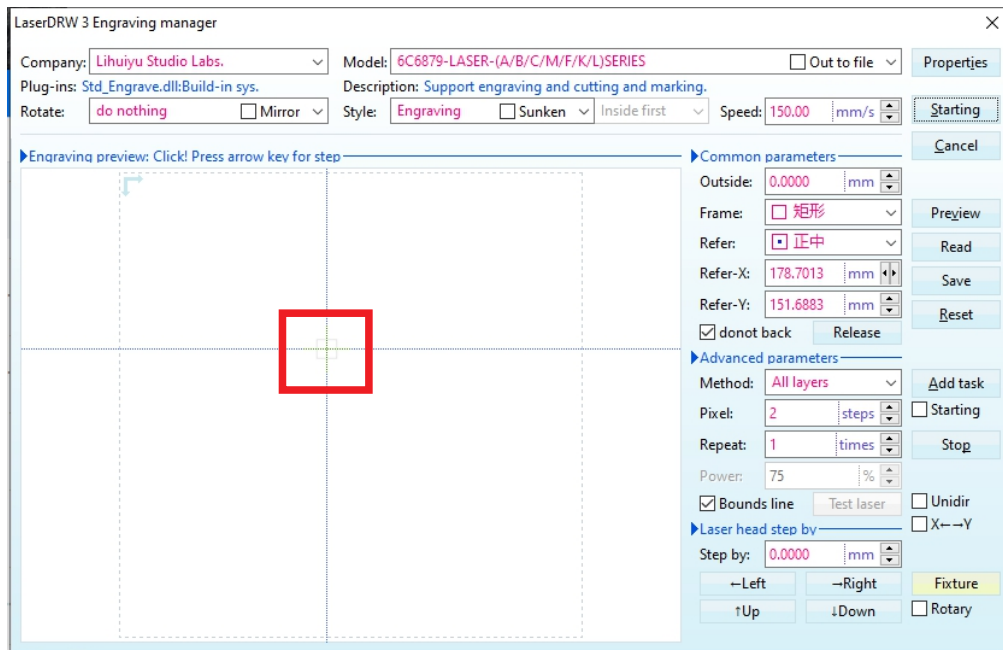
**Fig. 3-12**

Press “Engrave” on the Menu (Fig. 3-13), and you will hear the machine reset to its origin.



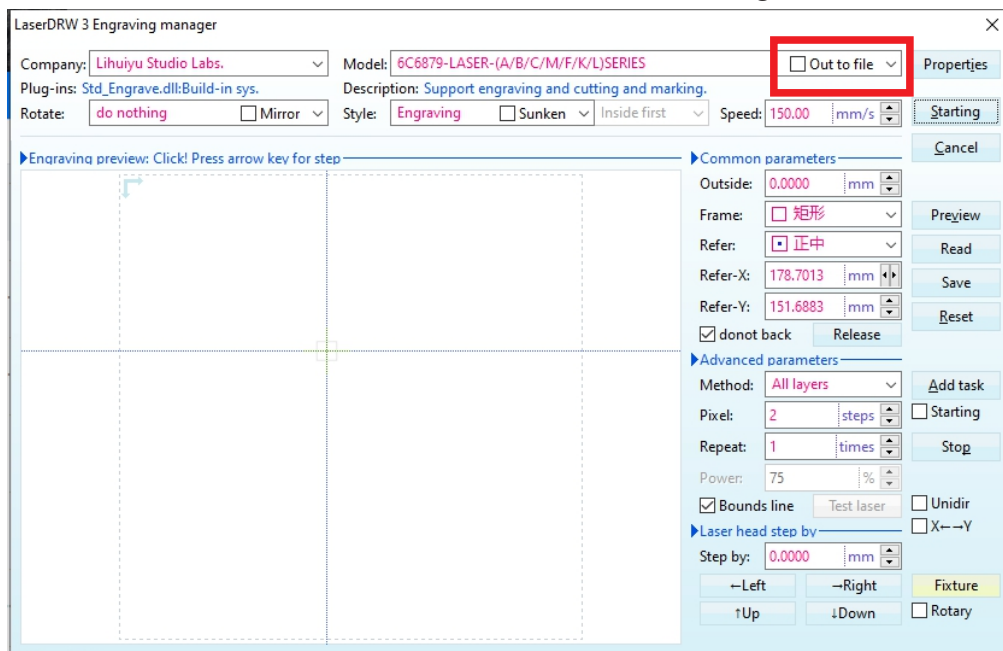
**Fig. 3-13**

In the Engraving Manager screen that appears, you can adjust and control the positioning of the laser head and your image by clicking and dragging the origin, the center of the blue cross (Fig. 3-14).



**Fig. 3-14**

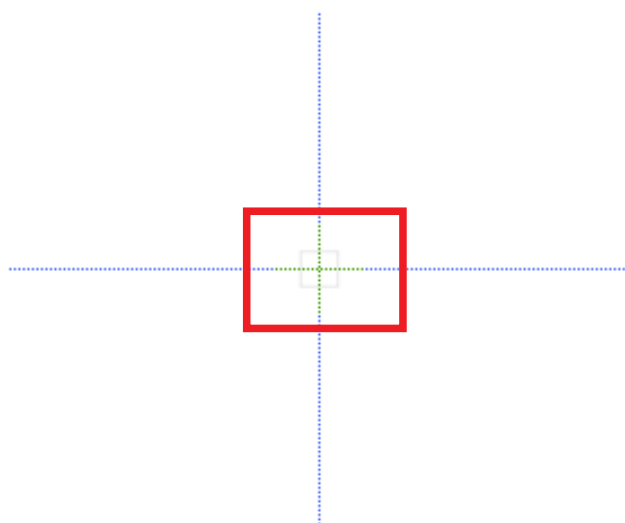
Before engraving or cutting, you must make sure that the file you want to process is being sent to the machine and not to another location. Make sure you have the “Out to file” box unchecked as in Fig. 3-15.



**Fig. 3-15 - “Out to File” Option**

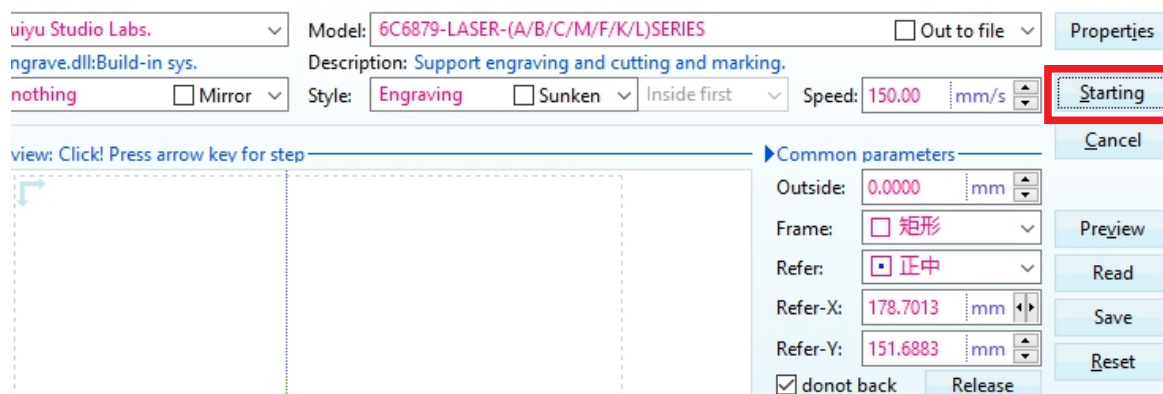
Clicking this box saves your file instead of engraving it.

The rectangle is placed below and to the right of the origin (at the center of the blue cross) (Fig. 3-16). We will refer to this position in a later example.

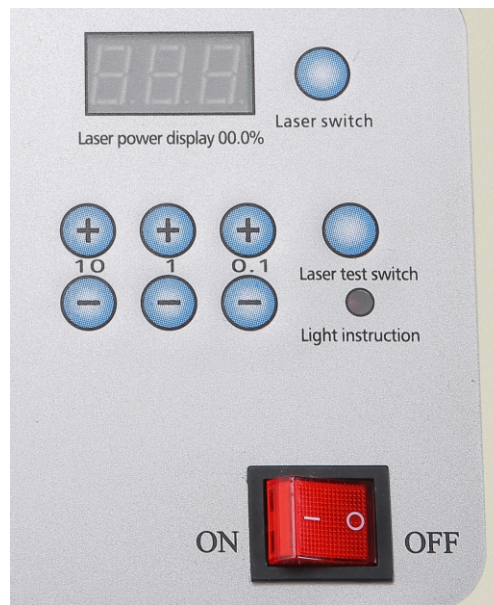


**Fig. 3-16**

Place your material on the bed and position the laser head accordingly. Once you are ready, press the “Starting” option to begin (Fig. 3-17). Make sure you have selected your desired wattage (power setting) using the control board on the machine (Fig. 3-18).

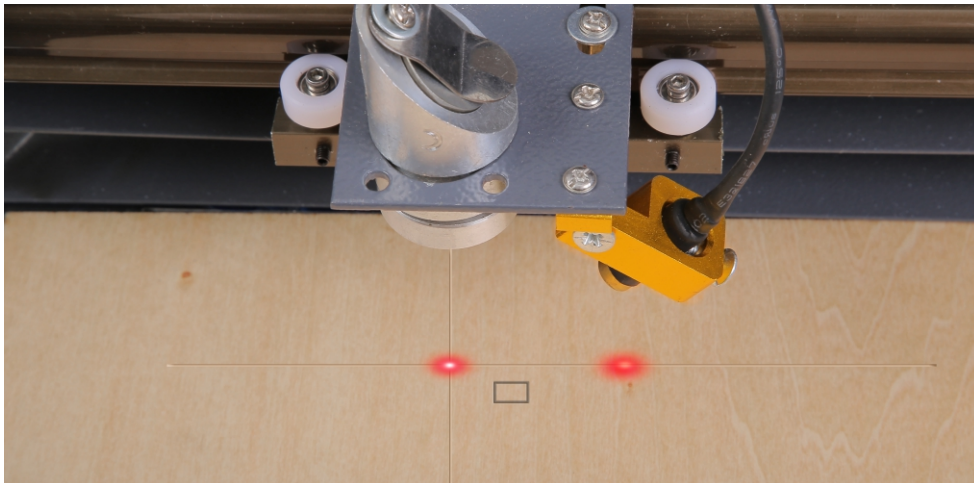


**Fig. 3-17**



**Fig. 3-18**

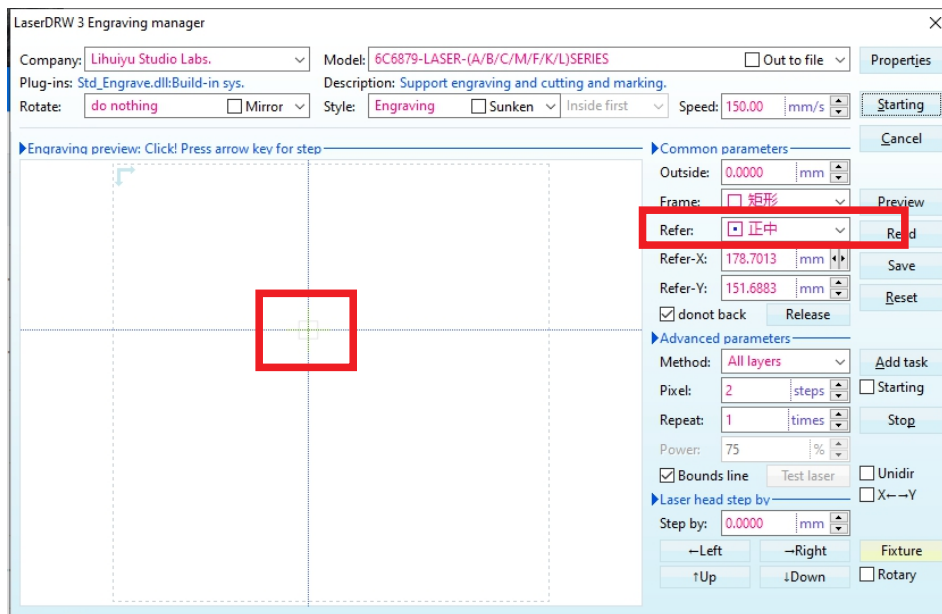
Some models are equipped with a red laser guide that will mark the laser head position, initially located at the origin, the center of the blue cross you see on your computer screen. This example can still be followed through even if your model does not have the extra laser guide. The cross on the wood is drawn to help visualize it. The rectangle is placed in the bottom right quadrant (Fig. 3-19). This is where the laser marked it.



**Fig. 3-19**

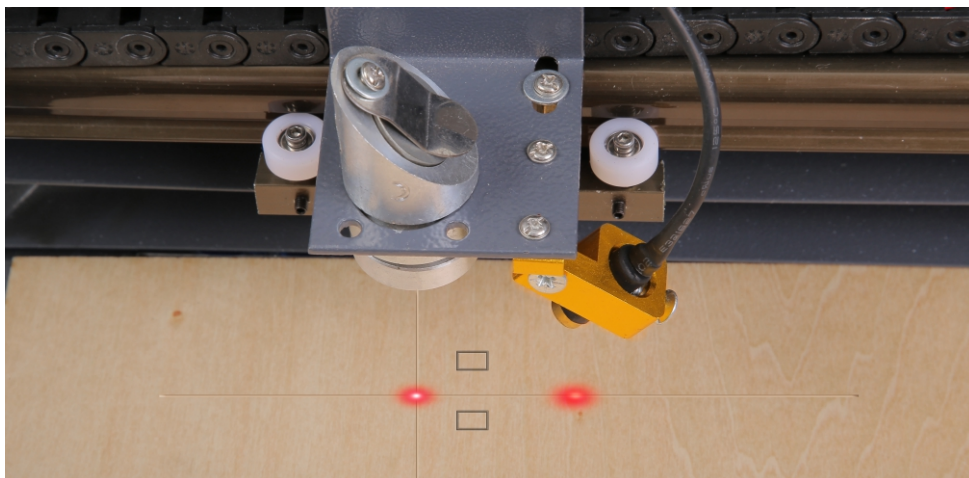
### **Step 5: Test Positioning**

You can adjust the positioning of your object/shape using the “Refer” option (Fig. 3-20). We will now change the location to the upper right corner.



**Fig. 3-20**

The laser now engraves your design in the upper right quadrant, up and to the right of the origin (Fig. 3-21). Keep this feature in mind when you are setting up your material and jobs. Always keep the cover lid closed while processing jobs.



**Fig. 3-21**

### Step 6: Read Up & Practice

Refer to the software and engraver manuals for additional options. You can adjust settings and parameters depending on your material and jobs. For example, clicking on “Style” allows you to choose between Engraving, Cutting, and Marking (Fig. 3-22).

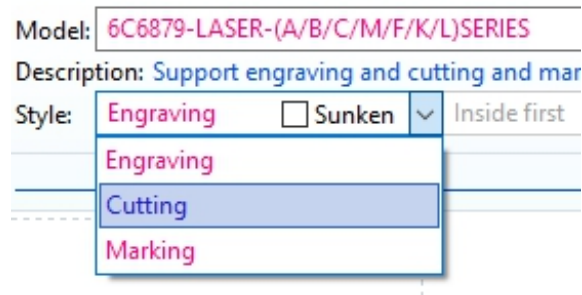


Fig. 3-22

### 4.3 Operation Procedures

#### Step 1: Prepare Your Design and Machine

Create or load your design in the engraver software.

When you are ready to engrave your material, check to make sure that the engraver is ready as well. Check that the water tank has plenty of cool (but not ice-cold) water. If working with a new material, double-check that it can withstand the heat of the laser engraver and that it will not release harmful fumes when processed. Check that the exhaust hose is secured in its window or that its purifier is working properly.

#### Step 2: Prepare the Material to be Processed

Make sure the material is dry and clean. Fix the material securely in place using the clamp. The top surface of the material should be at the same level as the clamp frame to keep the laser's focus distance correct. Your engraving material's target surface should be 2 inches (5 cm) away from the laser head tip to ensure proper focus distance, as shown in Figures 3-23 to 26 below.

**Note:** An incorrect focus distance will decrease the quality of your engraving.

#### Use the Focus Tool (optional)

Some of our desktop models include a 2" (5cm) focus tool, a small 2" ruler. Use it to double-check the distance between the laser tip and the target surface. If your model does not include a focus tool, you can use a simple ruler to measure the 2" (5cm) distance.

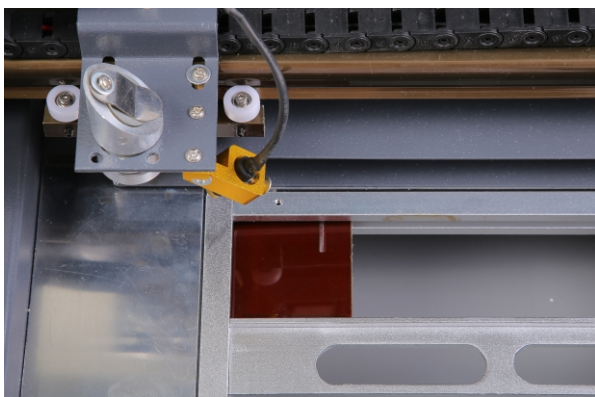


Fig. 3-23

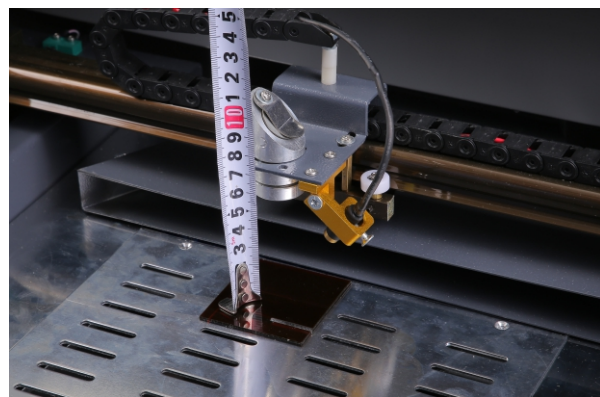


Fig. 3-24



Fig. 3-25

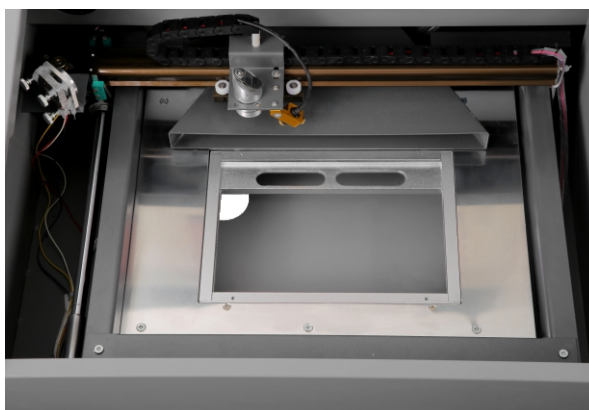
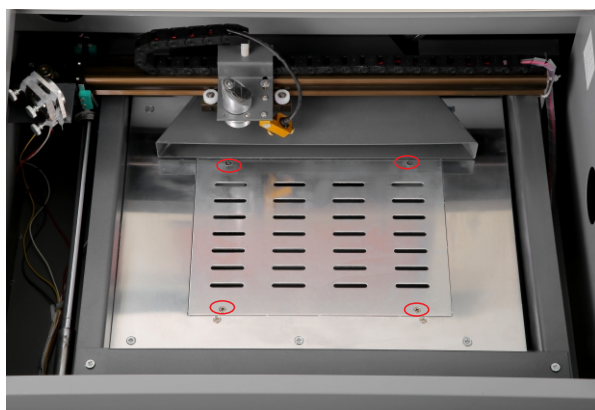


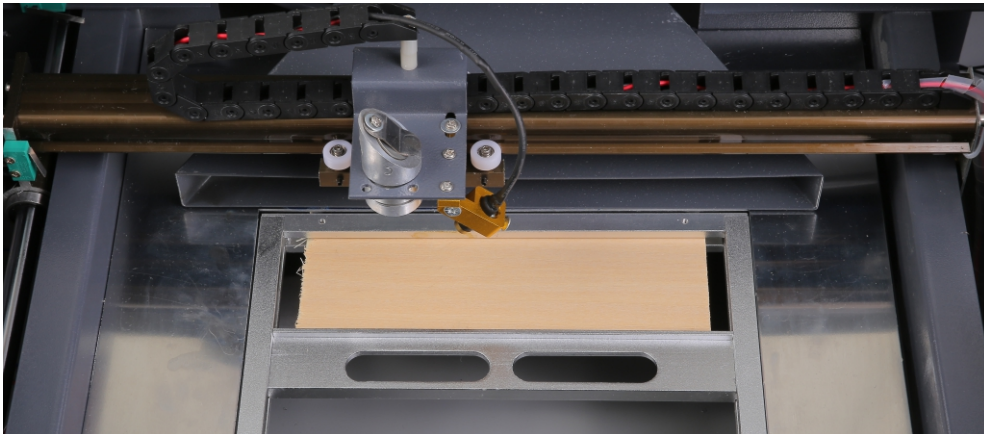
Fig. 3-26

### Removable Workbed with Stabilizer Clamp

This desktop model includes a removable workbed with a stabilizer clamp.

For thicker materials with extra height, you may need to remove the vented level board and place your target material at the bottom of the engraver to achieve the 2" (5cm) focus distance. Simply remove the four screws (one at each corner of the vented level board) and lift the vented level board out. However, this reduces the workbed's X and Y dimensions to 8" x 5". To use the stabilizer clamp, simply pull the spring-loaded slider towards you and place the target material between the two ends of the clamp.

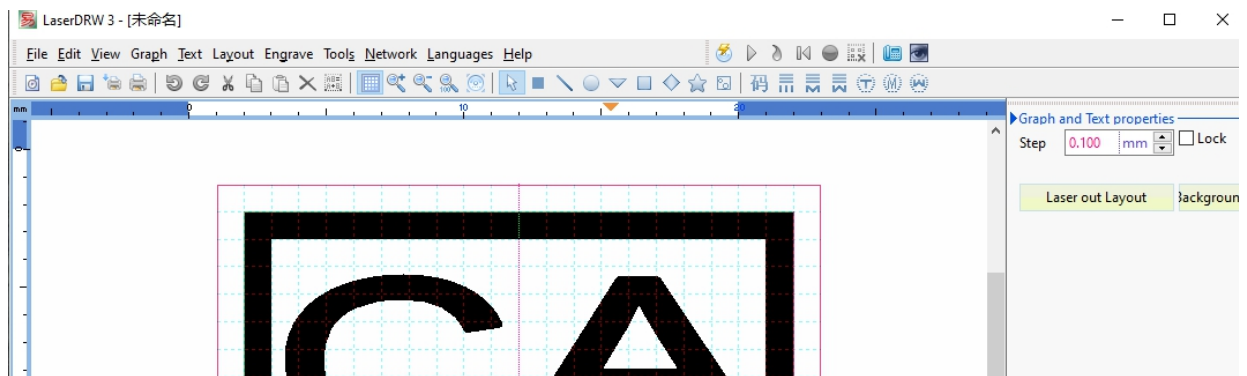




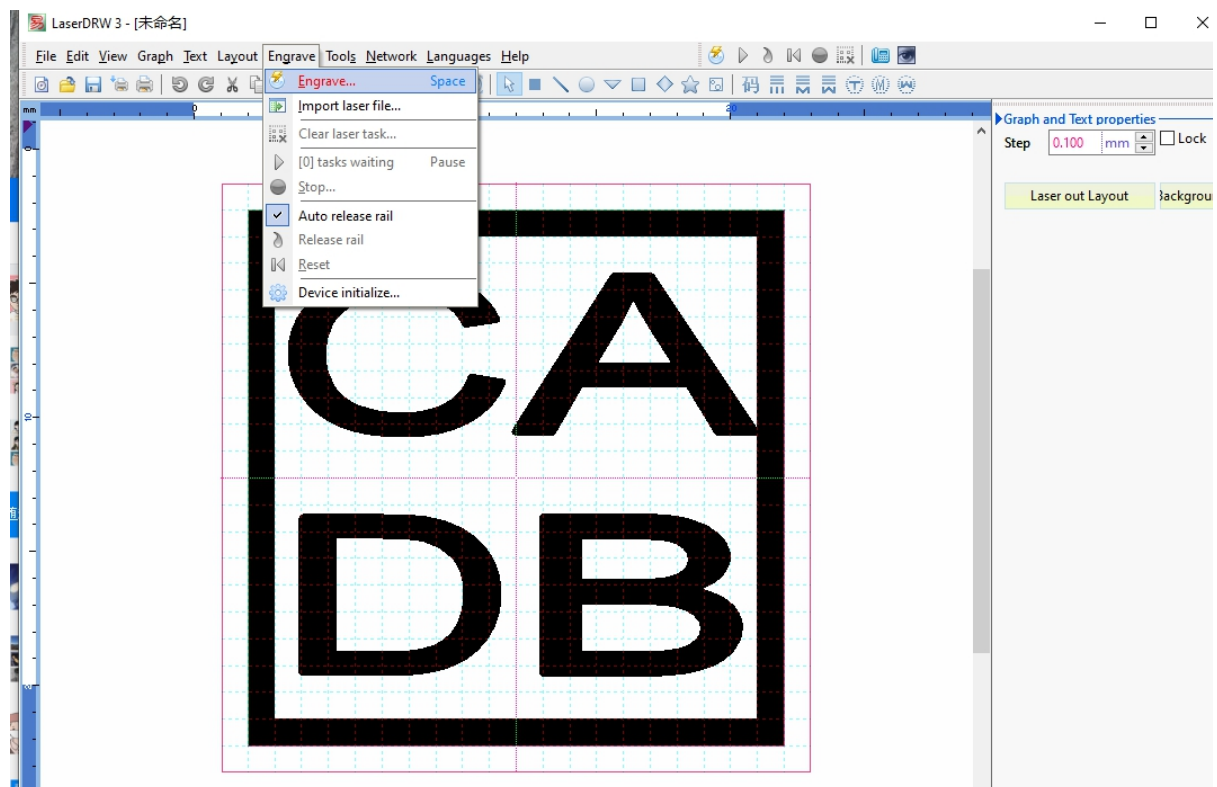
### Step 3: Select Engraving Placement

Move the placement of the design in the software to move the laser head to the correct location.

(1) Open LaserDRW (Fig. 3-27).

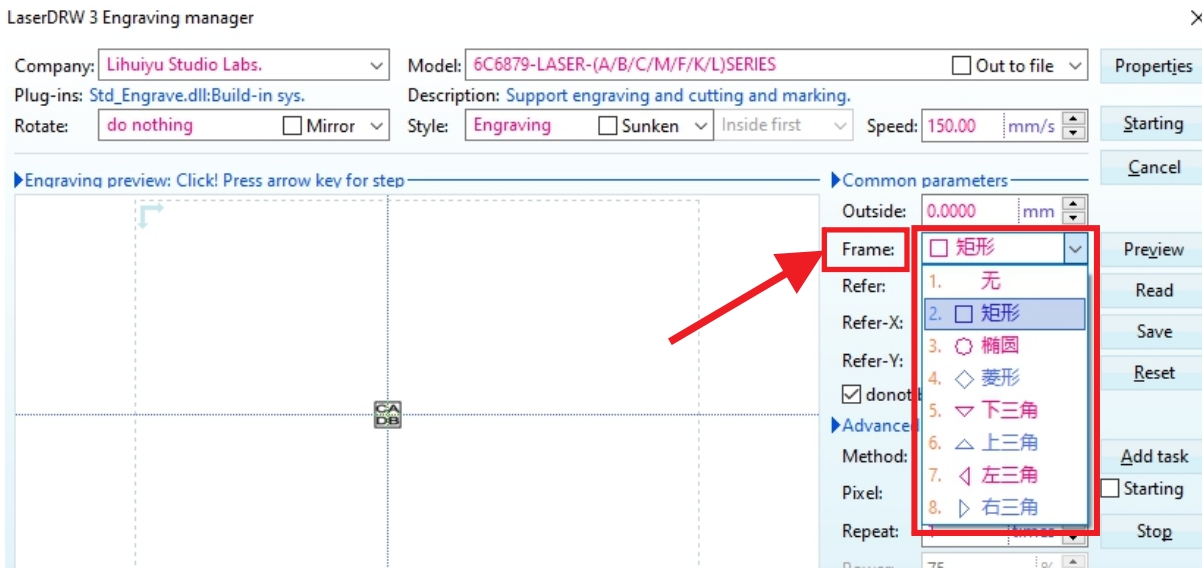


(2) Select “Engrave” in the “Engrave” menu (Fig. 3-28).

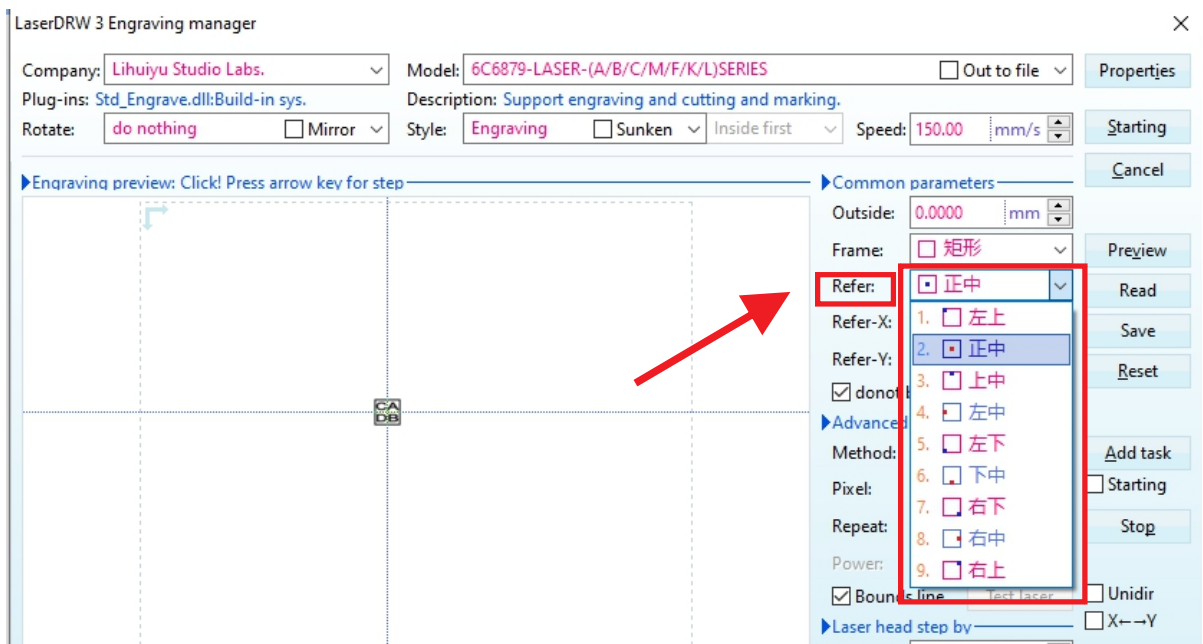




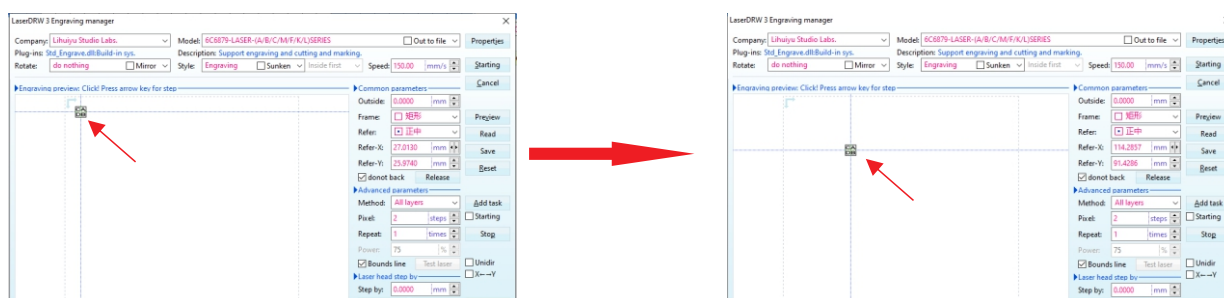
(3) Select the appropriate “Frame” for the image (Fig. 3-29).



(4) Use “Refer” to select the proper alignment of your design with the selected position (Fig. 3-30).



(5) Drag the design to the correct location in the grid to position the laser head correctly over the material (Fig. 3-31 & 32).



#### Step 4: Select a Power Setting

On the machine, select the laser power you wish to use. This will vary according to which kind of material you want to process. Customize your design's contrast and engraving depth by adjusting the parameters in your engraving software or directly through the control panel. If your engraving instructions detail the power setting in milliamperes, use the following conversion chart to find the appropriate power setting:

<b>Power %</b>	8	10	15	20	25	30	35	40	45	50	55	60	65	70	80+
<b>Current (mA)</b>	5	7	8	9	10	12	13	15	17	18	20	21	22	23	24

To increase engraving depth, increase the amount of energy per unit area by increasing laser power, increasing loop count, or slowing down the speed parameter. Engraving too deep, however, reduces image quality, especially for coated materials. When working with new materials, remember that you should always start on the likely low-end settings. If the effect is not yet strong enough, you can always rerun the design loop several times or rerun it with more powerful settings until you create the desired effect.

**Remember:** Running your laser tube above 70% power can significantly shorten the laser tube's lifetime (We recommend staying below 70% power to prolong the life of your laser tube).

#### Step 5: Begin Working

Set the engraving speed in the software, and output the job to the machine. It should begin working (See 4.3 if problems occur). Again, do not stare continuously at the laser, even through the protective acrylic window. However, watch for possible issues like sparks or fires and be prepared to extinguish a fire if necessary.

**Helpful Tips:** Make sure to double-check the resolution size vs. the image dimensions of the graphic in your Software Manual or settings to ensure a quality image.

#### Step 6: Examine Results & Adjust as Necessary

Once the laser has stopped, examine the quality of your first run and adjust the laser parameters on the control panel or in your software as necessary to create the desired effect.

### **Step 12: Shutdown Procedures**

When you have finished engraving, close your engraving software and then turn off your machine in the following order: laser power supply, control panel, any ventilation device, the water cooling system, and the emergency power button. Fully clean the workbed and empty the waste bin. For best results, lock and disconnect your laser engraver from its power supply between uses. Unplug it or turn off its intermediary surge protector.

## **4.4 Principles of Engraving Various Materials**

Generally, the engraving depth can easily be varied through laser power or speed. To increase the engraving depth, reduce the speed or increase the power setting. This way, you increase the amount of energy per unit area. Engraving too deep, however, reduces the quality of the details. With coated materials, the required power depends on the coating material and thickness of the coating. With the power set too high, the individual lines become too thick, reducing image quality. The resolution of the graphics should usually be set to 400-500 dpi. The dpi setting (number of laser Dots Per Inch) depends on the material. The lower this setting is, the lower the resolution of the engraved picture will be. This, however, reduces flaming and increases the energy of a pulse, which can improve the overall result (e.g., when engraving some plastics). The following instructions are suggestions to help speed safe work with a range of materials. The user should research the specific safety and engraving requirements of their specific material to avoid the risk of fire, hazardous dust, corrosive and poisonous fumes, and other potential problems. Once the product is known to be safe or appropriate protective equipment has been set up, it can be helpful to engrave a test matrix of small boxes produced at various speed and power settings to discover the ideal settings for your design. Alternatively, start with low power and fast speed settings and rerun your design as many times as needed, using progressively greater laser intensity.

### **Ceramics**

When engraving on ceramics, generally use moderate to high power. Using more loops rather than higher power and lower speed can help avoid cracking the material during work. Be mindful of the health risk posed by dust generated from ceramic engraving, especially for repetitive industrial applications. Depending on the material and amount of work, a fan or even a full ventilation system may be required to address the problem. Similarly, operators and others in the work area may need to use breathing PPE such as masks and respirators.

### **Glass**

When engraving glass, generally use high power and low speed. As with ceramics, it can be helpful to run more loops at lower settings to avoid cracks. Care must be taken when engraving

fiberglass and carbon fiber to avoid combinations of settings that produce a laser intensity great enough to damage the structural integrity of its component fibers, producing blurry marking. PPE should be worn to avoid exposure of the eyes, nose, mouth, and skin to the dust produced by working with either material, especially for repetitive industrial applications. Clothing worn while working with fiberglass should be washed separately afterward.

### **Leather**

When engraving leather products, generally use low to moderate power at high speed. Be especially attentive to the possibility of fire, as well as the dust produced in repetitive applications.

<b>40W Laser — Cutting Thickness of Leather</b>			
<b>Material Thickness</b>	1mm	2mm	3mm
<b>Speed (mm/s)</b>	25	20	15
<b>Power %</b>	20	22	25

### **Metal**

CO<sub>2</sub> laser engravers should not be used for marking, engraving, or cutting metal. They are best suited for working coatings applied to a metal base, and care must be taken not to attempt work on the underlying metal itself. A variety of coatings specialized for CO<sub>2</sub> engraving are available, and the user should follow the instructions provided as the parameters vary from product to product and metal to metal. Generally, work on aluminum coatings should be done more quickly at lower power, and work on steel coatings can be done more slowly at higher power.

### **Paper and Cardboard**

When engraving various paper products, generally use low to moderate power and fast speed. Test samples from each batch as only small parameter differences can separate effects that are too light from those that burn through the substrate. As with leather, be especially attentive to the possibility of fire, as well as the dust produced in repetitive applications.

<b>40W Laser - Cutting Thickness of Paperboard</b>				
<b>Material Thickness</b>	0.3mm	0.5mm	1mm	1.5mm
<b>Speed (mm/s)</b>	25	20	18	14
<b>Power %</b>	20	20	22	24

## Plastics

Plastics for engraving are available in many different colors and thicknesses and with many different coatings and surfaces. The majority of available plastics can be well engraved and cut with the laser. Plastics with a microporous surface seem to give the best result because less surface material needs to be removed. When engraving plastics, generally use low power and high-speed settings. Marking and engraving with too much power or at too low a speed can concentrate too much energy at the point of contact, causing the plastic to melt. Among other problems, this may produce poor engraving quality, noxious fumes, and even fires. High-resolution engraving can cause the same problem, so medium to low-resolution designs should be preferred for most plastics.

<b>40W Laser - Cutting Thickness of Acrylic</b>					
<b>Material Thickness</b>	1mm	2mm	3mm	4mm	5mm
<b>Speed (mm/s)</b>	13	11	9	7	4
<b>Power %</b>	20	23	25	35	45

## Rubber

Rubber's inconsistent composition density causes slightly varying engraving depth. Testing various settings on sample pieces of your specific rubber is highly recommended for the best results. When engraving rubber, generally use a consistently high power setting and create your effects by varying the laser's speed. Microporous rubber materials require a significantly higher speed than standard rubber. Engraving any kind of rubber produces a considerable amount of dust and gas. Depending on the amount of work, breathing PPE and/or a full ventilation system may be required to address the problem.

<b>40W Laser - Cutting Thickness of Rubber</b>					
<b>Material Thickness</b>	1mm	2mm	3mm	4mm	5mm
<b>Speed (mm/s)</b>	13	11	9	7	4
<b>Power %</b>	22	25	28	38	48

## Rubber

When engraving various kinds of stone, generally use moderate power and moderate to fast speed. As with ceramics and glass, be mindful of the dust created (especially for repetitive

industrial applications) and take similar measures to ensure the safety of users and others in the work area.

### Textiles

When engraving textiles like cloth and fleece, generally use low power and fast speed. As with leather, be especially attentive to the possibility of fire and dust.

<b>40W Laser - Cutting Thickness of Cloth</b>			
<b>Material Thickness</b>	0.2mm	0.3mm	0.4mm
<b>Speed (mm/s)</b>	30	28	26
<b>Power %</b>	18	19	20

### Wood

As with rubber, there is a huge variety of woods and testing your specific material is essential to get the best results. In general, wood with consistent grain and coloring engraves more evenly. Knotted wood produces uneven effects, while resinous wood produces greater edge contrast. Some softwoods like balsa, cork, and pine engrave well (albeit with low contrast) at low or moderate power settings and high speed. Others like fir suffer from uneven fibers that usually produce a poor effect no matter what you do. Hardwoods like cherry and oak engrave well at high power settings and low speed. Manufactured wood products can vary from brand to brand, mostly based on their glue composition and abundance. **MDF** works well but creates dark edges when cut.

In addition to the risk of fire with any wood product, extra care must be taken with the fumes from the glue used in plywood and other manufactured woods. Some are too dangerous to work with at all, while others require careful ventilation and the use of breathing PPE for repetitive industrial applications. Wood toxicity should also be examined, as the dust from some natural woods, including oleander and yew, can cause nausea and cardiac problems in high enough amounts.

<b>40W Laser - Cutting Thickness of Plywood</b>					
<b>Material Thickness</b>	1mm	2mm	3mm	4mm	5mm
<b>Speed (mm/s)</b>	17	15	13	7	4
<b>Power %</b>	20	23	25	35	45

## Chapter 5 — Maintenance



The use of procedures other than those specified herein may result in hazardous laser radiation exposure. Before any cleaning or maintenance work, always switch off the device and disconnect it from its power supply. Always keep the system clean, as flammable debris in the working and exhaust areas constitutes a fire hazard. ONLY allow trained and skilled professionals to modify or disassemble this device.

### **Helpful Tips:**

At least once a day, check for accumulated dust in the engraving system. Immediately clean all dirty areas after unplugging the machine. The cleaning interval strongly depends on the material that is being processed and the operating time of the device. Please bear in mind that only a clean machine guarantees optimal performance and reduces service costs.

## **5.1 Regular Maintenance**

### **1. Clean the Mirrors and Lens Daily**

Dust and engraving debris will accumulate on your mirrors and focus lens, resulting in energy loss and damage - they should all be cleaned frequently. We recommend cleaning daily or after each use.

The mirrors may be cleaned in place. Use a cotton swab with an acetone or alcohol cleaning solution. To avoid misaligning the laser beam's path, swab the mirror as gently as possible. For best results, begin in the center and rotate slowly to the outer edges in a soft circular pattern. Be careful not to damage the surface coating.

To clean the focus lens, remove it from the laser head, clean it in the same way as the mirrors, and then replace it. During replacement, be mindful to keep the concave side down.

### **Helpful Tips:**

Do not touch the surface of the mirrors/lenses after cleaning, as your hands can leave behind natural residues. To prevent this, wear sterile, single-use rubber gloves while handling the mirrors and lens.

### **2. Replace the Water in the Water Tank Weekly**

The water cooling system's importance cannot be overstated. Always ensure the cooling water remains between 60-70°F (15-21°C). Always use distilled water. For best results, change the water in the tank at least weekly to maintain the water cooling system's quality. Distilled water can leach chemical content from your water tank/hoses and spread these possibly corrosive particles into the laser components. This makes frequent water changes critical to prolonging the life of your laser tube. If distilled water is not available, deionized water is acceptable but can have corrosive effects on the laser tube, depending on its mineral content.

### **3. Clean the Water Pump and Water Tank Weekly**

Clean the water tank itself weekly, which can be done while changing the water. To clean the water tank:

- 1.) Turn off the laser engraver and unplug the pump.
- 2.) Disconnect the tank's water inlet hose, allowing it to drain automatically. 3.) Open the water tank, remove the pump, and clean the pump and tank.
- 4.) Replace the pump inside the water tank and reconnect the water inlet pipe. Then replace the tank's distilled water.
- 5.) Plug in the pump again, and allow it to run for 2–3 minutes to restore the water throughout the engraver's cooling system. Before starting the laser, visually confirm water running through the laser tube and check the water temperature.

#### **4.Clean the Guide Rails Biweekly**

For best results, we recommend cleaning the engraver's guide rails every two weeks. To clean the guide rails, turn off the laser engraver. Move the laser head to the right or left. Wipe away all dust and debris with a dry cotton cloth until it is shiny and clean. Next, clean and lubricate the Y-axis guide rail. We recommend adding a small amount of white lithium grease to the rails/screws at least every two weeks. Gently move the head slowly along the Y-axis guide rail several times to evenly distribute the lubricant.

#### **5.Periodically Inspect the Optical Path Alignment**

Because the mirrors of your engraver's optical path are fixed, but the focus lens can acquire bias during operation, some optical path offset is possible. For best results, repeat the "Optical Path Alignment" procedures in section 4.2 before every project. Otherwise, use it when an optical path offset is noticed during operation.

#### **6.Clean the Exhaust Fan as Needed**

After long periods of use, the inside of the fan will accumulate dust, making it less effective at removing fumes and dust produced by engraving. To clean the exhaust fan:

- 1.) Turn off the laser engraver, remove the exhaust pipe, and clean the exposed fan's dust.
- 2.) At the same time, clean the exhaust pipe itself before reconnecting it to the fan.

The rate of dust accumulation will vary depending on the materials processed and the working environment's air quality. Still, you should always cease work and clean your exhaust fan if you notice it making more noise than usual.

## **5.2 Optical Path Adjustment**

### **Beam Path Alignment**

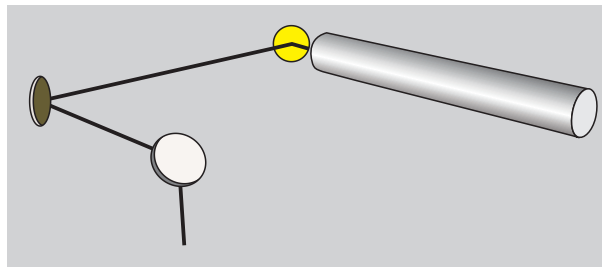
Proper beam alignment is important for the machine's overall efficiency and the quality of engraving/cutting outcomes. Our machines go through a complete beam alignment before shipping. We recommend users do a quick beam alignment test before use to double-check the



accuracy of the mirrors and get familiar with beam alignment procedures. After long periods of use, the beam alignment might become a little inaccurate. If so, perform a beam alignment, as shown below. We recommend performing a beam alignment test every week, depending on your work volume. **\*Your machine may appear slightly different from the images shown below.**

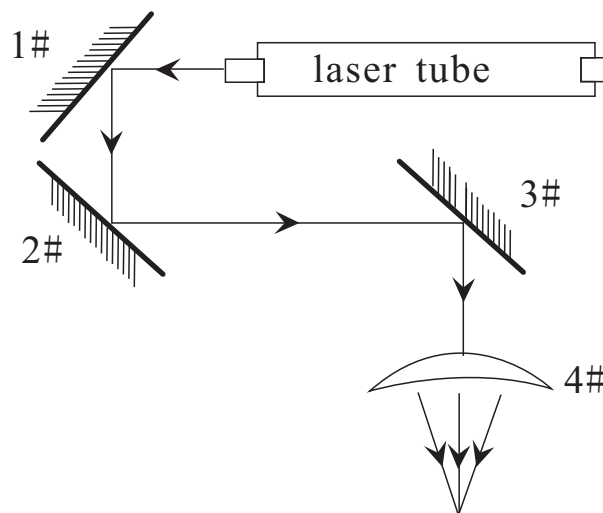


**WARNING: Performing a beam alignment can expose the operator to small amounts of laser radiation if not careful. Please follow the procedures correctly and always take caution when performing a beam alignment.**



### Components of a Beam Alignment

The components shown in the image below make up the laser beam path, starting from the laser tube to the laser head.

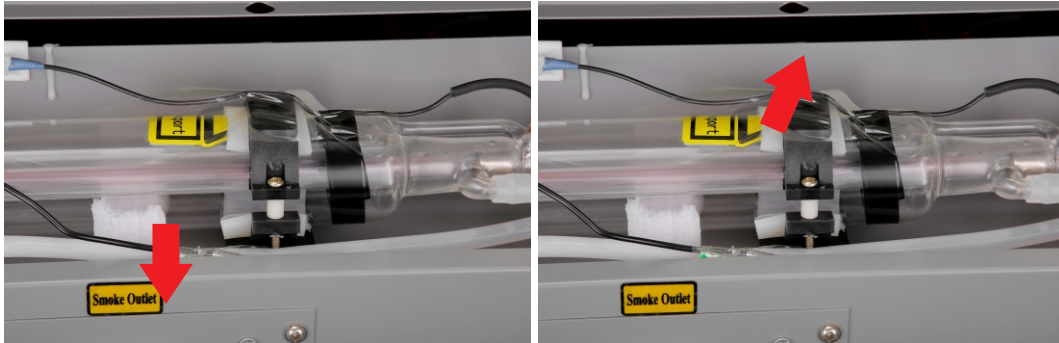


**Fig. 4-1 Optical Path Diagram**

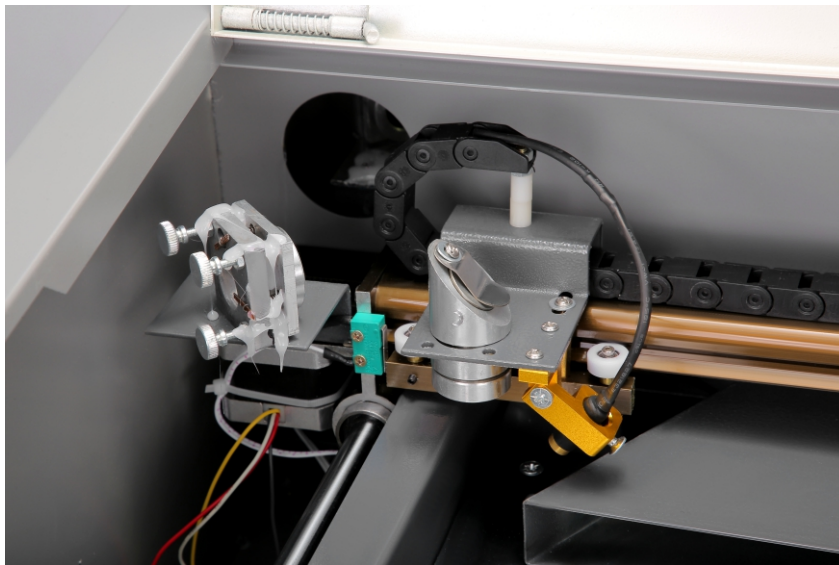
When aligning or realigning the optical path of your laser, follow these steps:

1. Use a low-power setting. We recommend a current of about 8mA or 11% power.
2. Test the alignment of the laser tube and first mirror:
  - a. Put a small piece of double-sided adhesive tape included with your engraver on the first mirror (#1). Make sure the adhesive area over the mirror is covered.

- b. Push the Test Switch button to activate the laser tube. You should see a dot appear on the tape near the center of the mirror. If it is misaligned, adjust the position of the laser tube to correct this.



3. Test the alignment of the first and second mirrors at close range:
- Put a small piece of double-sided adhesive tape on the second mirror (#2). Make sure the adhesive area over the mirror is covered.
  - Move the X-axis beam to Position A (Fig. 4-2) near the laser tube.
  - Push the Test Switch button to activate the laser tube and produce a dot on the tape. To avoid possible laser injuries, please put a carton board in front of the second mirror to find the laser dot's general position.

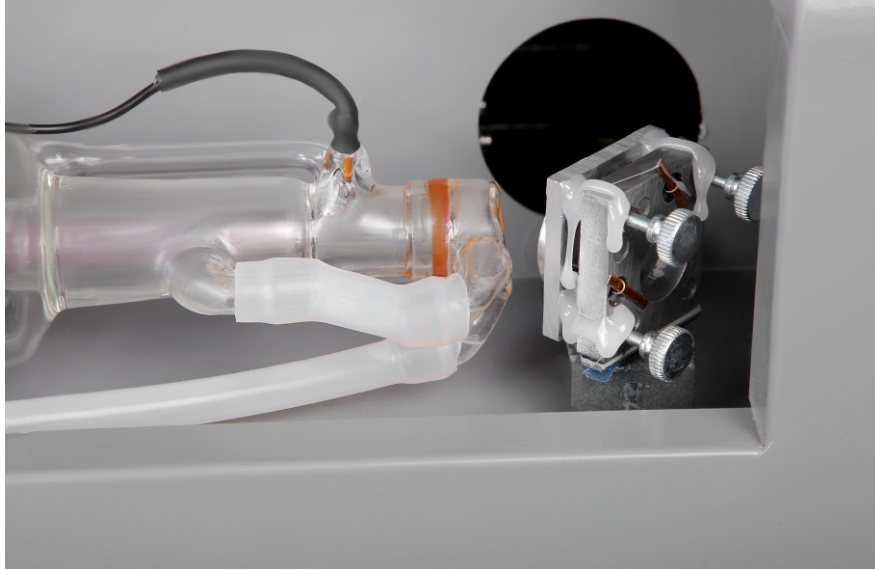


**Fig. 4-2 - The Second Mirror in Position A**

If the laser dot is not in the center of the second mirror, you will need to adjust the angle of the first mirror using the set screws behind it (Fig. 4-3):

- Loosen the nuts which restrain the three adjusting set screws.
- Correct the angle horizontally by turning the two set screws.

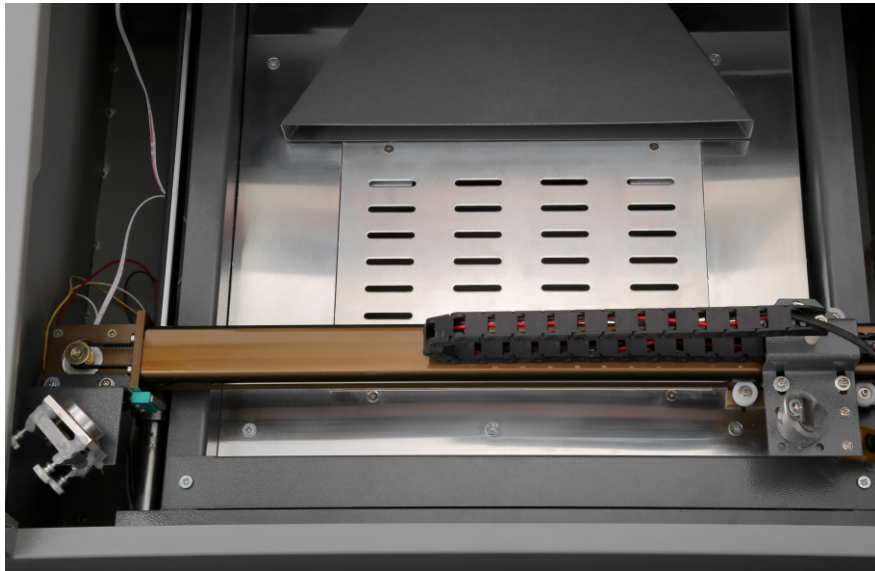
3. Correct the angle vertically by adjusting the bottom set screw.



**Fig. 4-3 - Adjustment Set Screws Behind the First Mirror**

4. Test the alignment of the first and second mirrors when distant:

- a. After aligning the first and second mirrors in Position A, slowly and gently move the X-axis beam to Position B (Figure 4-4) far away from the laser tube.
- b. Press the Test Switch button to activate the laser and produce a second dot on the tape on the second mirror.

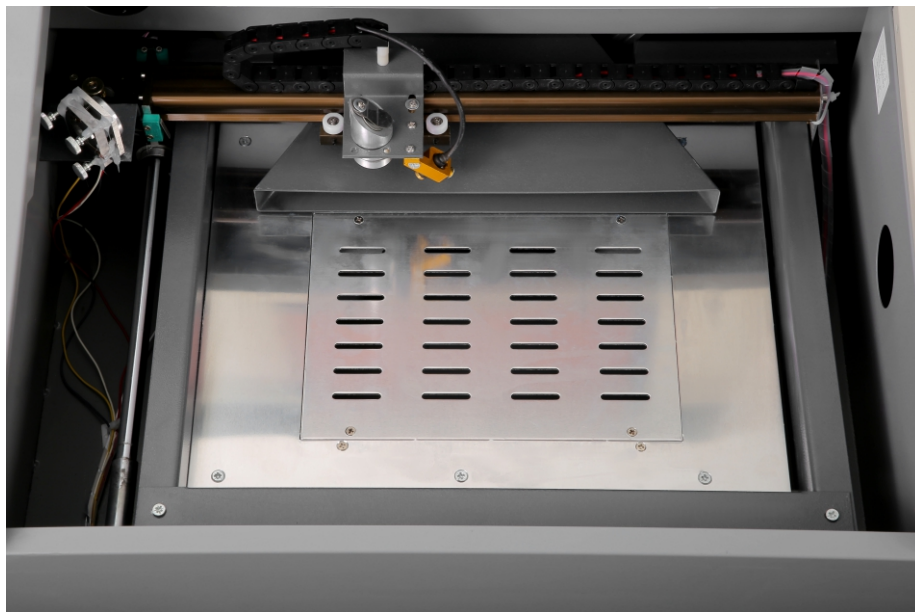


**Fig. 4-4 - The Second Mirror in Position B**

If the first and second dots on the tape are not identically placed, repeat the process of adjusting the first mirror's set screws described in Step 3 above until the two dots overlap.

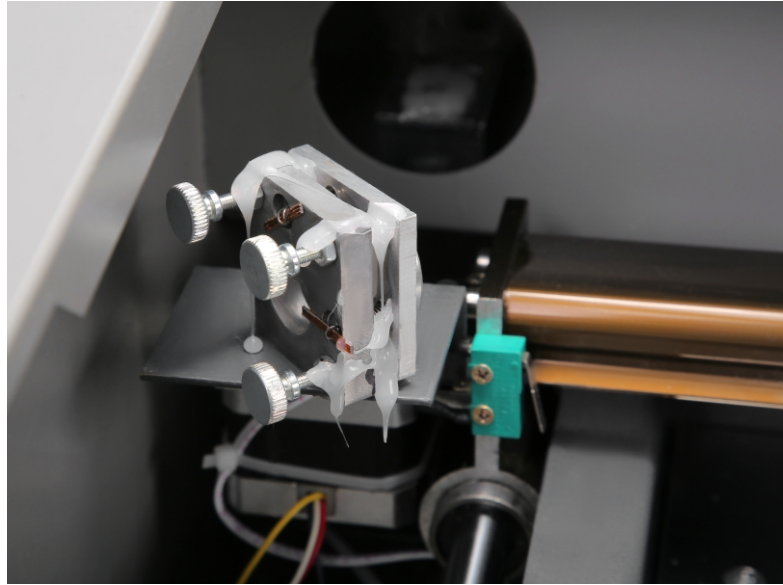
5. Test the alignment of the second and third mirrors when close:

- a. Put a piece of double-sided adhesive tape on the third mirror (#3).
- b. Move it slowly and gently along the Y-axis guide rail until it is in Position 1 (Fig. 4-5) near the second mirror.
- c. Press the Test Switch button to get a laser dot on the tape. To avoid any possible laser injuries, please put a carton board in front of the third mirror to get the general position of the laser dot.



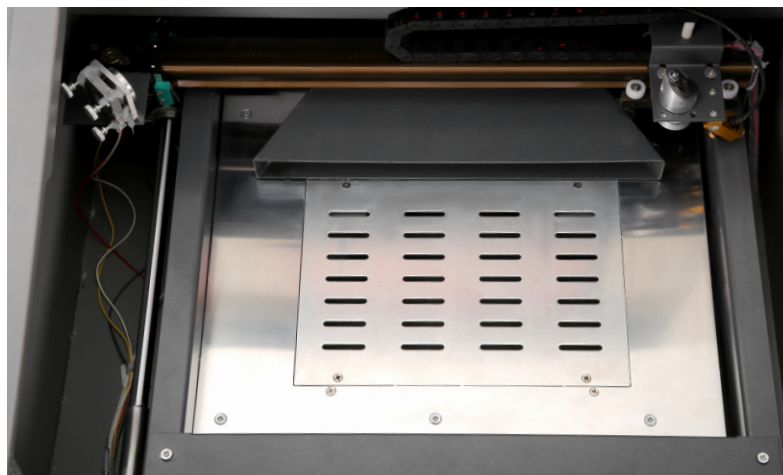
**Fig. 4-5 - The Third Mirror in Position 1**

If the laser dot is not in the center of the third mirror, you will need to adjust the angle of the second mirror using the set screws behind it (Fig. 4-6). These are similar to the set screws behind the first mirror described in Step 3 above and work identically.



**Figure 4-6 - Alignment Set Screws for the Second Mirror**

6. Test the alignment of the second and third mirrors when distant:
  - a. When the second and third mirrors are well-aligned in Position 1, slowly and gently move the third mirror along the Y-axis guide rail until it is in Position 2 (Fig. 4-7) far away from the second mirror.
  - b. Press the Test Switch button to activate the laser and produce a second dot on the tape on the third mirror.

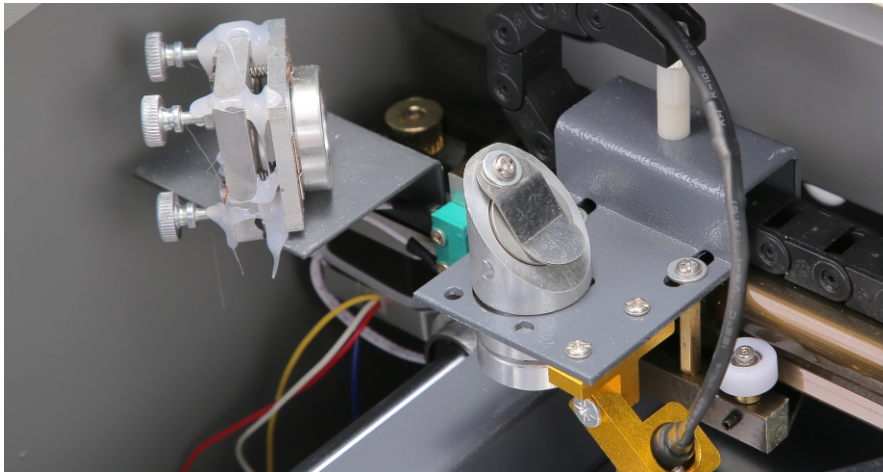


**Figure 4-7 - Third Mirror in Position 2**

If the first and second dots on the tape are not identically placed, repeat the process of adjusting the second mirror's set screws described in Step 5 above until the two dots overlap.

7. Test the alignment of the third mirror with the focus lens:

- a. Put a piece of double-sided adhesive tape beneath the laser head. Apply pressure to the tape to leave the imprint of the hole where the Laser Beam exits the Laser Head.
- b. Press the Test Switch button to get a laser dot on the tape. The dot should be near the center of the hole.



**Figure 4-8**

If the dot is vertically off-center, correct the third mirror's alignment by adjusting the flange on top of the laser head (Fig. 4-8). If the misalignment persists, adjust the screws on the laser head's frame (Fig. 4-8).

## 5.3 Troubleshooting

In the text below, we provide common problems that may occur with your machine and quick solutions to help fix them. Should an issue arise beyond the scope of these troubleshooting tips, please contact our customer service support team for help or a trained repair professional.

### **Nothing happens when the engraver is turned on.**

Check the power cord and fuses. The machine may be unplugged, or the fuse may need replacement.

### **Nonstop laser-firing**

Check the electrical grounding wire and connections.

### **Laser head homing issues**

For abnormal tests of the limit switch's metal probe, try adjusting the metal sheet to touch the limit switch.

**The machine does not work when instructed by the software.**

Check that the data cable is well connected to both your computer and the engraver. Check that the engraver is turned on and well-grounded. If the necessary drivers for the USB connection have not been installed, do so and repeat the command.

**No laser beam is emitted during operation.**

Check that the water cooling system is working properly and the tank is well supplied with cool (but not icy) distilled water. Check the optical path for misalignment and, if necessary, perform the optical path adjustment procedure in 4.2.

**The laser head moves erratically.**

Check that the engraver is well-grounded. If it already is and the problem persists, reduce the engraving speed.

## 5.4 Disposal Instructions



Electrical products should not be disposed of with household products. In the EU and UK, according to the European Directive 2012/19/EU for the disposal of electrical and electronic equipment and its implementation in national laws, used electrical products must be collected separately and disposed of at the collection points provided for this purpose. Locations in Canada and the US may have similar regulations. Contact your local authorities or dealer for disposal and recycling advice.

## Contact Us

We sincerely thank you for your support. If you are satisfied with the machine's performance, please consider leaving a positive review at the website listing where you made your purchase. If you encounter any problem regarding this engraver, do not hesitate to contact us with your order ID at **MP Customer support Email: support@monportlaser.com and Amzone/eBay Customer support Email:sumicoltt887@163.com**, and our customer service team will respond within 24 hours. Thank you, and we hope you will choose us again for your next purchase!