

THINK OUTSIDE THE STADIUM  
**HOMETEAM**  
**SEATS**

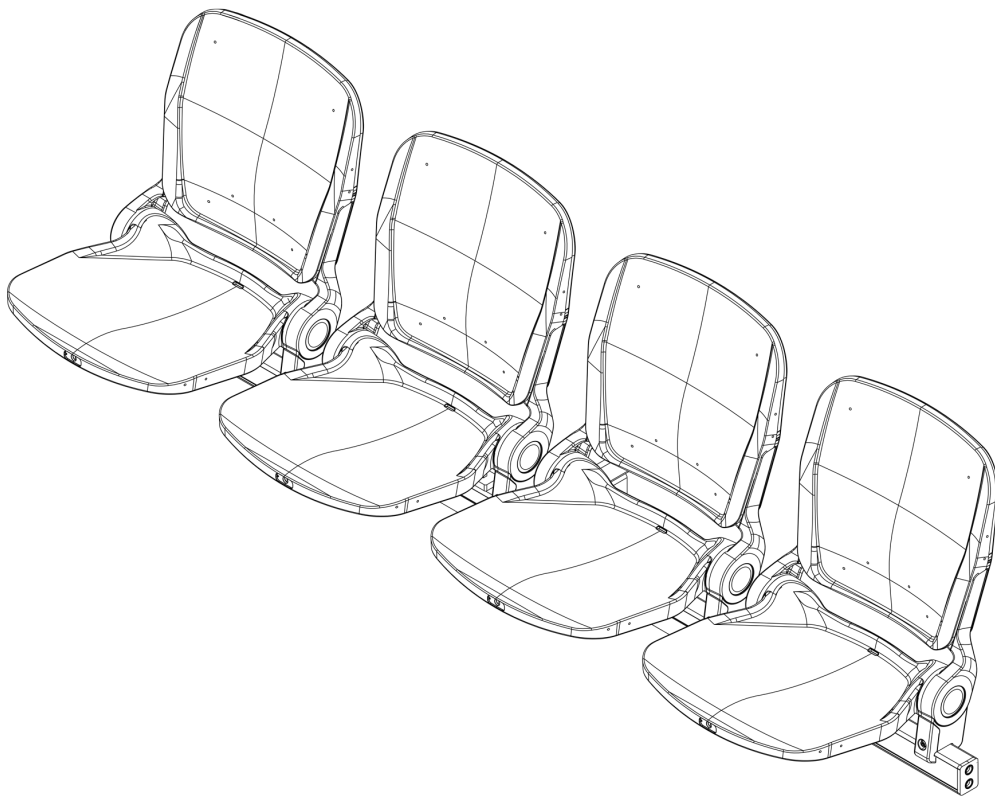

# 4 Seater

Assembly Instructions

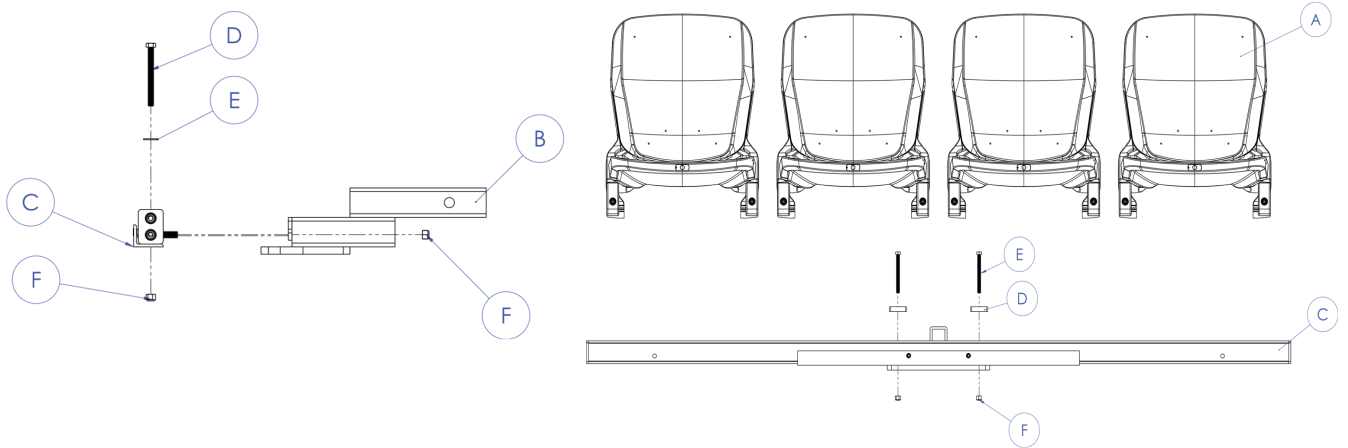
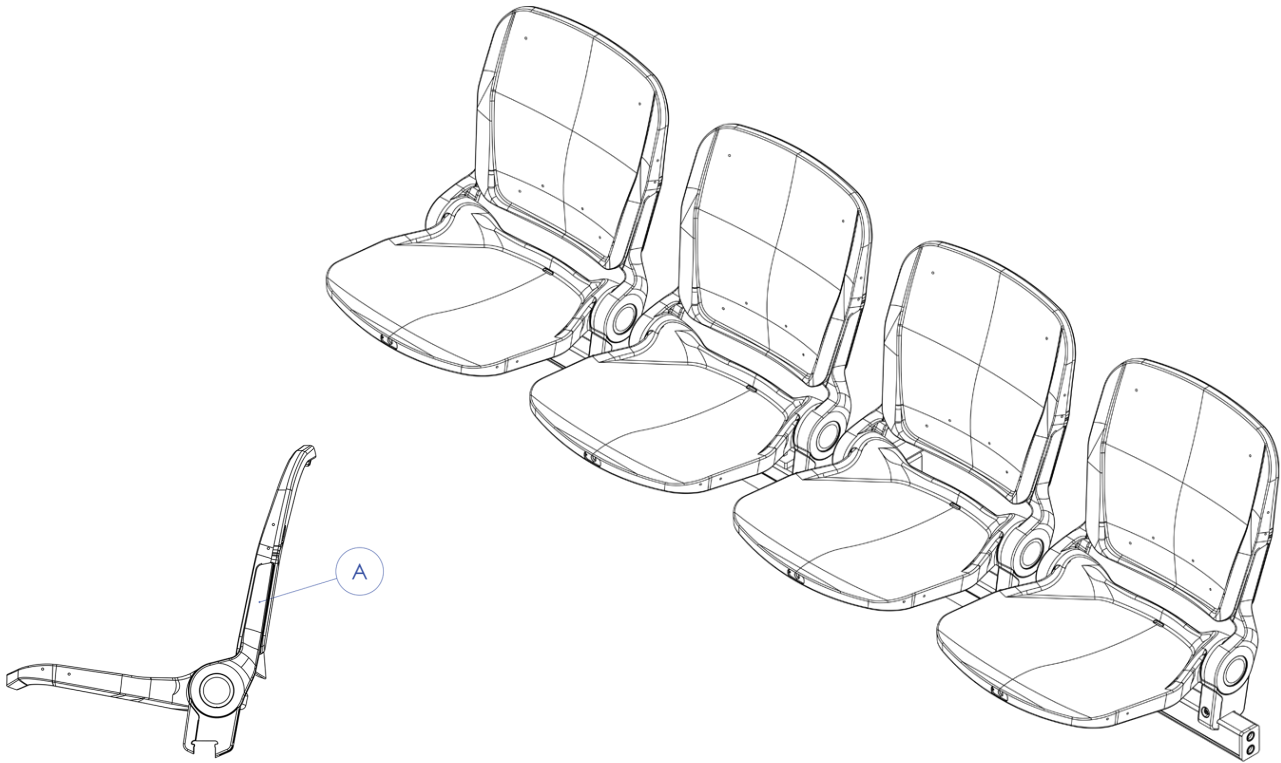

PARTS	DESCRIPTION	QTY.
A	OVATION SEAT	4
B	HITCH MOUNT	1
C	SEAT SUPPORT BAR	1
D	SUPPORT WASHER	2
E	3/8" -16 X 4" BOLT	2
F	3/8" NYLOCK WASHER	4

All Hitch N' Sit seats have locks on them with key provided, to prevent unauthorized use while vehicle is in motion. The Stabilizer accessory is recommended with Hitch N' Sit 3-Seaters and 4-Seaters to prevent movement and minimize any wobble while attached to vehicle.

All Hitch N' Sit seating systems are provided with a keyed hitch pin to securely lock into the hitch receiver. Our Hitch Adapter is made exclusively to work with our seats and fits in any 2" hitch receiver. The Beam of the Hitch N' Sit has a designated spot in the center to move your license plate to, ensuring it is in view while on the road. This applies to all Hitch N' Sit seating systems except for the 2-Seater with Table, which does not cover your license plate.



HITCH LOCK AND KEY

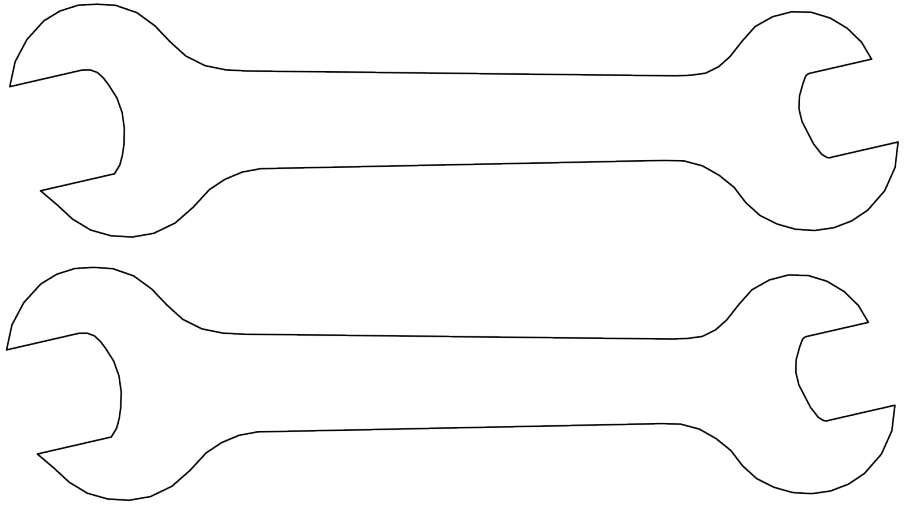

(2X) 9/16" - 1/2" COMBO WRENCH

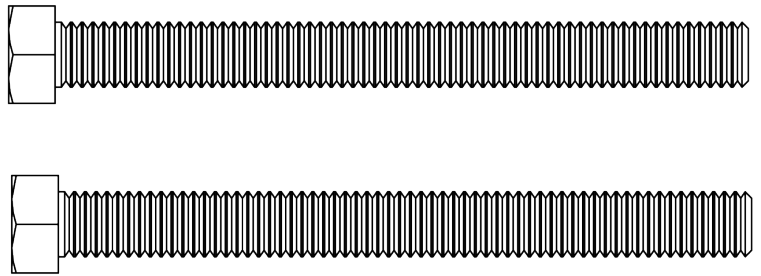

(2X) 3/8"-16 X4" HEX BOLT

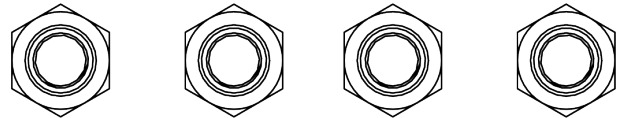

(4X) 3/8"-16 NYLOCK NUT



T-40 WRENCH

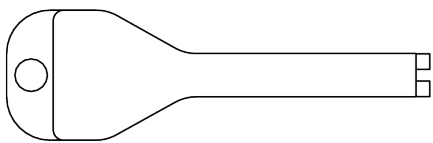

SEAT KEY

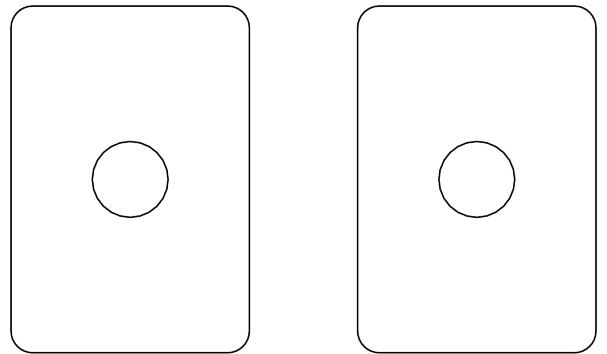

(2X) 3/8" SUPPORT WASHER

# How To Assemble Your 4 Seater

## Attaching Your Hitch Adapter To The Beam

1. Position the Hitch Adapter (Part B) to accept the bolts that will come through the two holes in the center of the Beam (Part C)

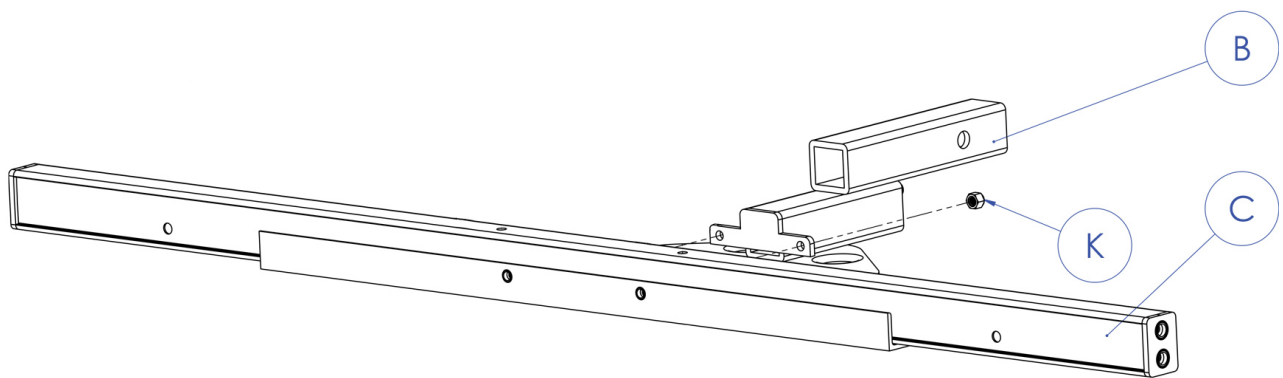

2. Place a Support Washer on bolt and slide through beam (Part C) and hitch adapter (Part B)

3. Fasten Nylock Nut (Part K) onto each bolt and securely tighten. The Nylock Nut should be fastened as shown in the diagram.

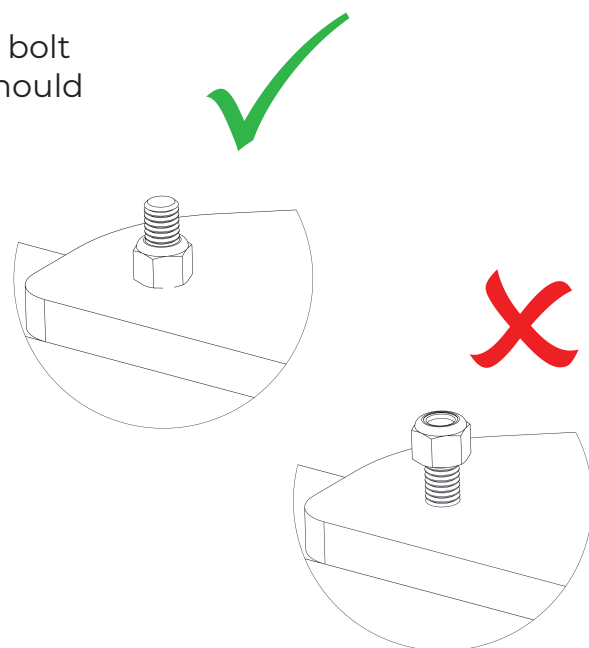

## Attaching Your Seats To The Beam

1. Line your seat (**Part A**) up starting at the center of the beam (**Part C**)

2. Lock bottom of seat (**Part A**) onto the beam (**Part C**) by making sure the ribbed edge is in the groove of the chair tab. Tighten with the T40 tool

3. Repeat Step 2 for each seat and be sure to align all seats (**Part A**) on the beam (**Part C**) evenly, Following the spacing measurements, shown below

