



BESPOKE
GLASS
LIGHTING

COLLECTION

MERLINO

SUSPENSION

MERLINO

SUSPENSION

zafferano

BESPOKE
GLASS
LIGHTING

E27 IP20 CE

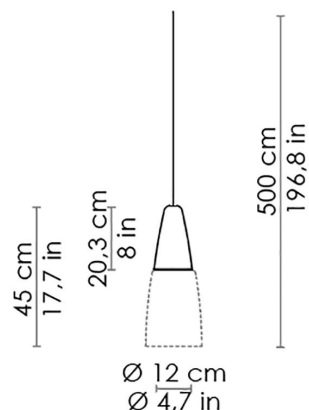

Mouth-blown borosilicate glass. Matte white, dark grey or rust painted metal parts. Transparent cables. Customizable product.

CODE	COLOR
------	-------

DIMENSIONS AND HOLES

Dimensions	Ø 12 x 45 - h 500 cm / Ø 4,7 x 17,7 - h 196,8 in
------------	--

ILLUMINOTECHNICAL SPECIFICATIONS

Source	E27
Type	E27
ip	IP20
total Watt	70W HS
Lamp life	minimum 3 years guaranteed

ELECTRICAL SPECIFICATIONS

Voltage	220-240V
Frequency	50-60 Hz

PHYSICAL SPECIFICATIONS

Thermal dissipation	passive
---------------------	---------

We reserve the right to change the specifications of our product. For the latest information on the product visit www.zafferanoitalia.com