

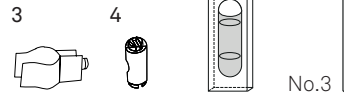

## BANGA

BNGA SG LED UL | SET UP

### CONTENTS

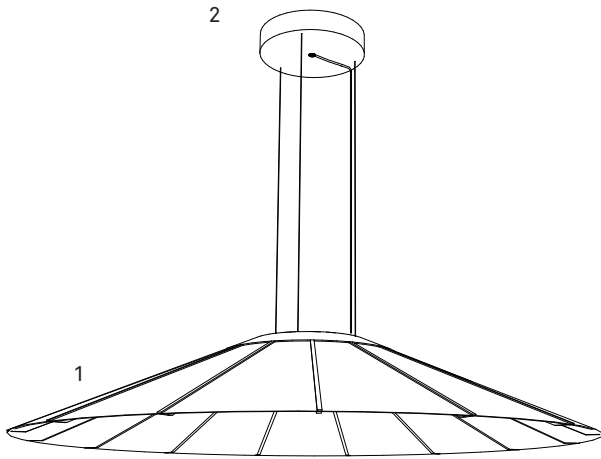

1 Shade.	1 un.
2 Canopy.	1 un.
3 Cable clip.	2 un.
4 Stoppers.	3 un.
5 Level.	1 un.
6 Allen key N°3.	1 un.

### TECHNICAL SPECIFICATIONS

#### Integrated LED



**Circular Module**  
 1 x 46,2W - 1400mA  
 120-277V 60Hz ~  
 52W

120 - 277V



#### WEIGHT

Net Weight	15,1 Lb
Gross Weight	105,6 Lb

### WARNINGS

Before assembly and installing this product, carefully read the following:

Turn off the mains before installing the lamp. Dry location only. This lamp is for indoor use only.

**WOOD VENEER:** Due to the natural nature of the material sometimes one may note slight undulations in the wood veneer. This is a natural reaction to humidity or different climatic conditions and should go away with use.

Since wood is a natural material, a gradual change in tone may occur over time. Furthermore, if the lamps have been purchased at different times, there will be differences in colour and tone, particularly in light coloured veneers. Luziferlamps S.L. will not be held responsible for this.



**PROTECTIVE FILMS:** Don't forget to remove all protective films from the acrylic surfaces of your lamp.

MORE INFO:  
<http://www.lzf-lamps.com/guarantee/>





ASSEMBLY INSTRUCTIONS

1.

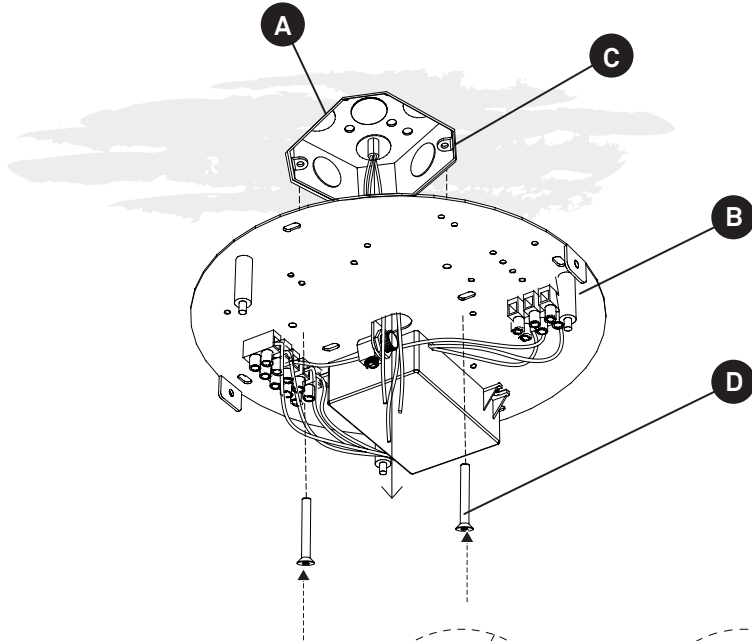

1. The canopy is made up of a back plate with the electrical connections on it and a front cover.

Feed the electrical wires (C) from the mains through the electrical back plate (B), fix back plate to the junction box (A) with the most adequate screws (D) (not supplied) and prepare to wire up.

2.

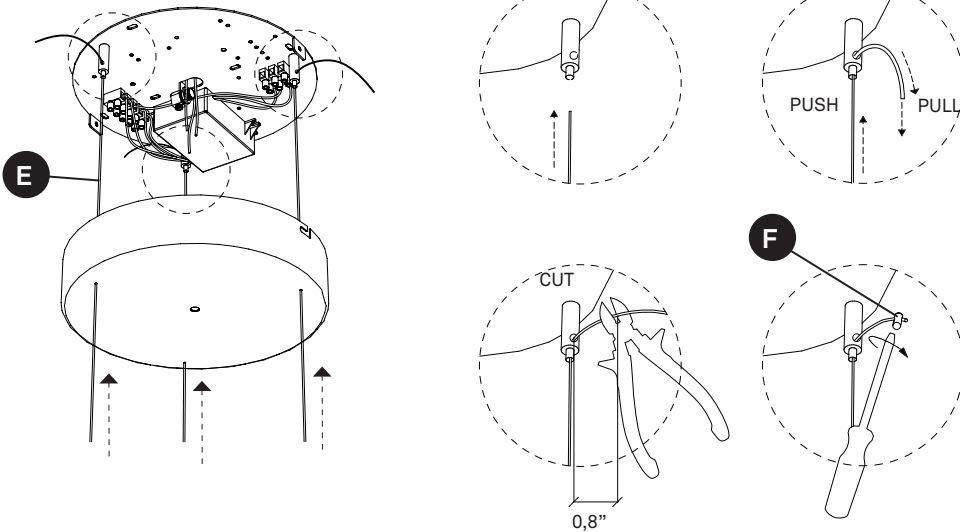

2. Adjust the height of your lamp by raising or lowering the stainless steel adjustment cable (E) and cut off the excess.

**IMPORTANT!** Pay attention to the numeration of the suspenders and steel cables. They must match.

For added security put on the stopper (F) and tighten it.

**Note:** if you want to roll up the excess stainless steel wire instead of cutting it off, do so but make sure that this wire cannot touch any of the electrical connections in the canopy.

Level the lamp with the level supplied, adjusting the height of the steel cables if necessary the suspenders.

3.

**OPTION 1  
NON DIMMABLE**

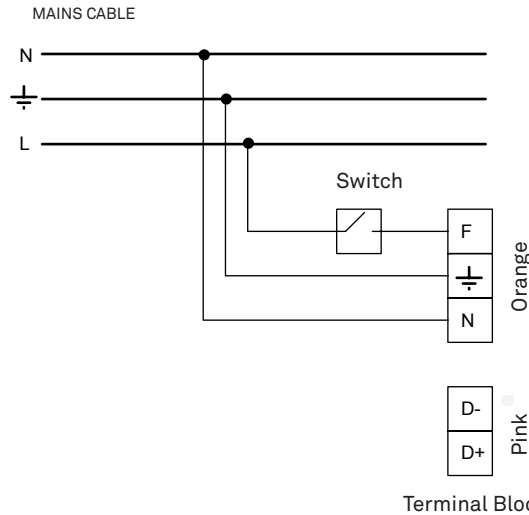

**3. MAINS CONNECTION OPTIONS**

Turn off the mains before installing the lamp.

Connect the lamp to the mains as follows.

**OPTION 1: NON DIMMABLE**

You should have a three wire cable coming from the mains.

Connect poles **N** and **GND** (⊕) as shown in the terminal block Orange. Connect the line (**L**) that goes through the switch installation to the pole **F** (terminal block Orange).

Poles D- and D+ are not used.



ASSEMBLY INSTRUCTIONS

**OPTION 2  
DIMMING**

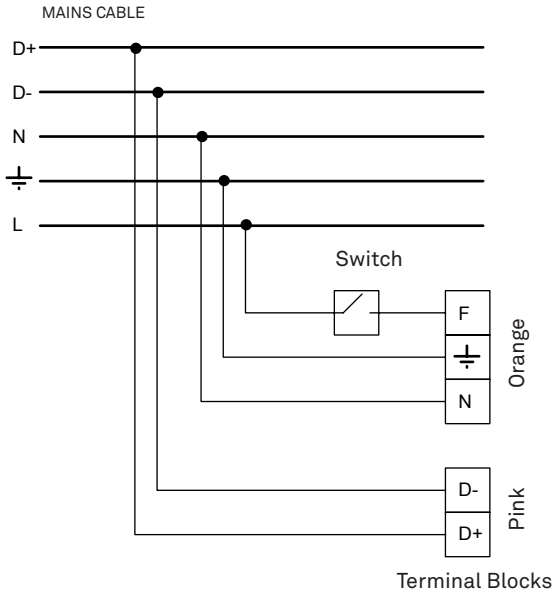

**OPTION 2: DIMMING**

You should have a five wire cable coming from the mains.

Connect poles **N** and **GND** (⊕) as shown in the terminal block Orange. Connect the line (**L**) that goes through the switch installation to the pole **F** (terminal block Orange).

After connecting the mains wires to the terminal block take the other two wires (the +/- dimming controls) and connect them to the dimming terminal block (terminal block Pink).

**OPTION 3  
LINE DIMMING  
ONLY 120V**

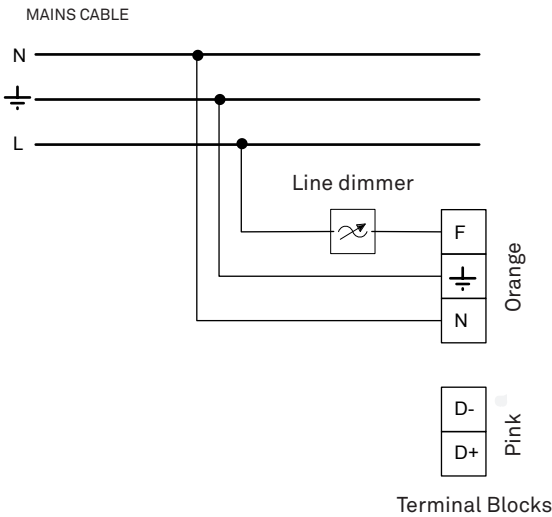

**OPTION 3: LINE DIMMING**

You should have a three wire cable coming from the mains.

Connect poles **N** and **GND** (⊕) as shown in the terminal block Orange. Connect the line (**L**) that goes through the line dimmer installation to the pole **F** (terminal block Orange).

Poles D- and D+ are not used.

4.

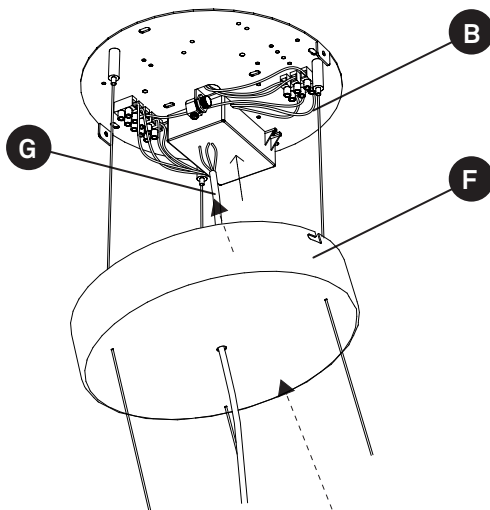

4. Now take the 3 cables coming from the lamp (G), and feed them through the canopy cover (F). Then, make the connections to the driver in the canopy (B) as indicated at point 5.



ASSEMBLY INSTRUCTIONS

5. LAMP CONNECTION

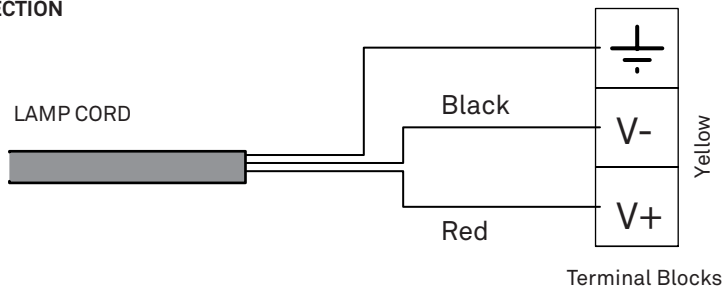

5. LAMP CONNECTION

In the canopy (B) connect the electrical cable from the lamp to the terminal block indicated (Yellow).

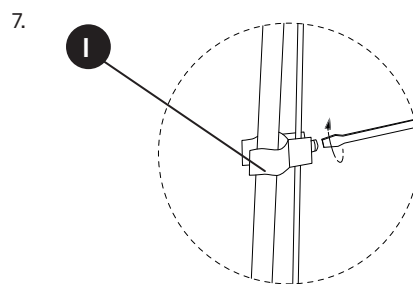
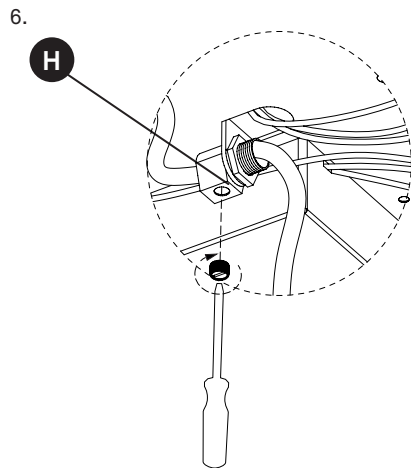

6. Tighten the screw on the electrical cable trap (H).

Once all your wiring is complete raise the canopy and screw on the canopy support screws that holds the cover in place.

7. Put on the cable clips (I) and clip them to the electrical cable.

8. Turn on the mains again.

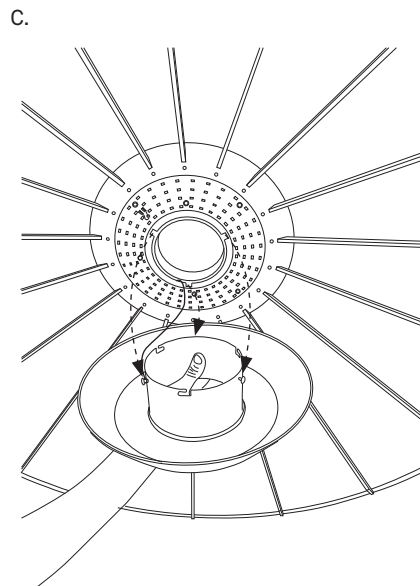
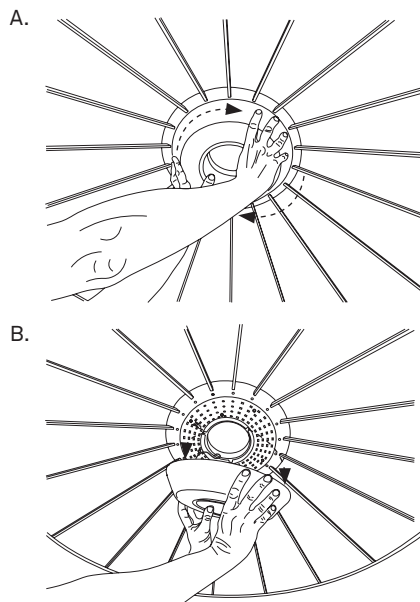

How to unmount the diffuser.

A - Take the acrylic diffuser with both hands and turn it counter clockwise till it comes free.

B - Once the diffuser is free pull it gently downwards separating it from the fixture. The diffuser is joined to the main fixture via a security cable.

C - Once you have removed the diffuser you can clean it inside with a soft clean cloth and a non aggressive window cleaner.

To put the diffuser back on follow the same steps backwards.

**Note:** Be careful not to touch the LED's with your fingers as this can effect the life of the individual LED.

© Luziferlamps, S.L.  
Valencia, Spain. 2018.  
All rights reserved.  
www.import-ent.com  
support@import-ent.com

GENERAL CARE INSTRUCTIONS

REV.06-2018

D38\_328

Use and care of your lamp.

You have just purchased an original handmade product by LZP. Your lamp is made out FSC® certified natural wood with our patented veneer finish Timberlite®. This treatment both protects and safeguards the wood veneer against breakages.

Depending on the type of fixture use a feather duster, soft cleaning cloth or damp cloth for cleaning. On our more delicate shades, like those made from wood strips, a feather duster or an air blower is preferable. In our more solid shades a damp cloth may be used. Clean only the flat surface of the veneer with the cloth, and please avoid any moisture contact along the edge of the veneer.

Acrylic Diffusers

The acrylic diffusers on your lamp can be cleaned with a regular window cleaning spray and a soft cloth. Do not use solvents of any kind.

Integrated LED

All LEDs are included in your lamp. Never touch the LED surface with your bare hands as this may reduce the life of your LED.

Precautions

Luminaire for indoor use only.

Avoid direct sunlight, strong indirect sunlight and moisture on your lamp. Unplug the lamp before cleaning or changing the light bulb.

Installation of the fixture should only be performed by qualified electrical personnel or by the LZP service department.