

ASSEMBLY INSTRUCTIONS  
ISTRUZIONI DI MONTAGGIO  
INSTRUCCIONES DE MONTAGE  
MONTAGE-ANLEITUNG  
INSTRUCCIONES DE MONTAJE

## FLOED

STORAGE MILANO / 2020

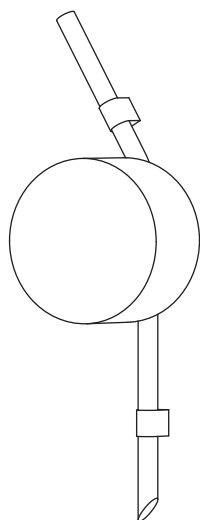



Class I / Classe I / Classe I / Schutzklasse I / Clase I

- EN. Appliance suitable for installation on normally inflammable surfaces.
- IT. Apparecchio idoneo ad essere installato su superfici normalmente in infiammabili.
- FR. Appareil destiné à être installé des surfaces normalement inflammables.
- D. Gerät, welches auf Oberflächen installiert werden kann, die normalerweise entzündbar sind.
- ES. Aparato apto para ser instalado sobre superficies normalmente inflamables.



- EN. It certifies the conformity of the product to the european community low voltage directive.
- IT. Attesta la conformità del prodotto alle disposizioni delle direttive comunitarie.
- FR. Il atteste la conformité du produit aux dispositions des directives communautaires.
- D. Das Zeichen bestätigt die Übereinstimmung des Produkts mit den Bestimmungen der EU-Richtlinien.
- ES. Certifica la conformidad del producto a las disposiciones de las normas de la comunidad.



- EN. The use of the WEEE symbol indicates that this product may not be treated as household waste.
- IT. Il simbolo RAEE utilizzato per questo prodotto indica che quest'ultimo non può essere trattato come rifiuto domestico.
- FR. L'utilisation du symbole WEEE indique que ce produit ne peut pas être traité comme déchet domestique.
- D. Durch Verwendung des WEEE-Symbols weisen wir darauf hin, dass dieses Produkt nicht als normaler Haushaltsmüll behandelt werden darf.
- ES. El símbolo RAEE en un producto indica que éste no se puede eliminar como cualquier otra basura.



## WARNING

The safety is guaranteed by the appropriate use of the following instructions, so you must keep them. Always disconnect the main voltage before working on the appliance. Never use abrasive products or aggressive detergents for cleaning the lamp. If the external cable of this appliance is damaged, it must be replaced by the manufacturer, its after sales service or other equivalent qualified person only in order to avoid any danger. Kundalini will not provide a replacement until the nature of defect has been determined.

## ATTENZIONE

La sicurezza dell'apparecchio è garantita con l'uso appropriato delle seguenti istruzioni, pertanto è necessario conservarle. Togliere sempre la tensione prima di operare sull'apparecchio. Per pulire la lampada non usare mai prodotti abrasivi o detersivi aggressivi. Se il cavo esterno di questo apparecchio viene danneggiato, deve essere sostituito esclusivamente dal costruttore, dal suo servizio assistenza, o da personale qualificato equivalente, al fine di evitare pericoli. Kundalini non effettuerà nessuna sostituzione se non dopo aver accertato la natura del difetto.

## ATTENTION

La sûreté de l'appareil n'est garantie qu'en suivant scrupuleusement les instructions ci-après. Il est donc nécessaire de les conserver. Isoler l'appareil du secteur avant toute manipulation. Pour nettoyer la lampe, ne jamais utiliser de produits abrasifs ou de nettoyeurs agressifs. Si le câble externe de cet appareil est endommagé, il doit être remplacé uniquement par les soins du constructeur, par son service après-vente ou bien par le personnel équivalent, et ce afin d'éviter tout danger. Kundalini ne remplacera aucun appareil sans en avoir pu vérifier le défaut.

## ACHTUNG

Die Sicherheit dieses Artikels wird nur durch die strikte Befolgung der nachfolgenden Betriebsanleitung gewährleistet. Bitte heben Sie diese unbedingt auf. Vor allen Arbeiten ziehen Sie bitte den Stecker aus der Dose. Für die Reinigung der Lampe niemals Schleifmittel oder aggressive Reinigungsmittel verwenden. Sollte das Außenkabel der Lampe beschädigt werden, ist es ausschließlich vom Service-Dienst des Herstellers oder gleichwertigen, qualifiziertem Personal auszutauschen, um somit Gefahren zu vermeiden. Kundalini leistet grundsätzlich erst nach einer gründlichen Überprüfung Ersatz.

## ATENCIÓN

La seguridad del aparato está garantizada sólo con el uso apropiado de las instrucciones siguientes, por lo tanto es necesario atenderlas puntualmente. Desconectar siempre la alimentación antes de trabajar en el aparato. Nunca utilice productos abrasivos o detergents agresivos para limpiar la lámpara. Si el cable externo de este aparato se deteriora será necesario sustituirlo; la sustitución podrá efectuarla exclusivamente el fabricante, su servicio de asistencia o personal cualificado equivalente para evitar peligros. Kundalini no efectuará sustitución alguna hasta después de haber verificado la naturaleza del defecto.

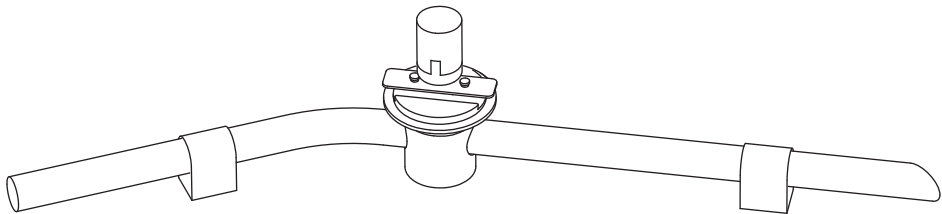

**BOX N.1**



**#2.5**

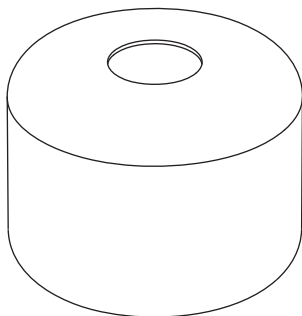

**BOX N.2**

.1

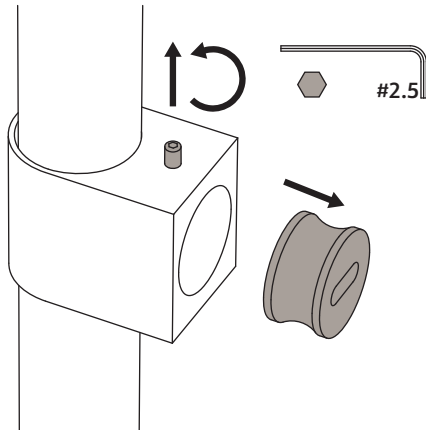

.2

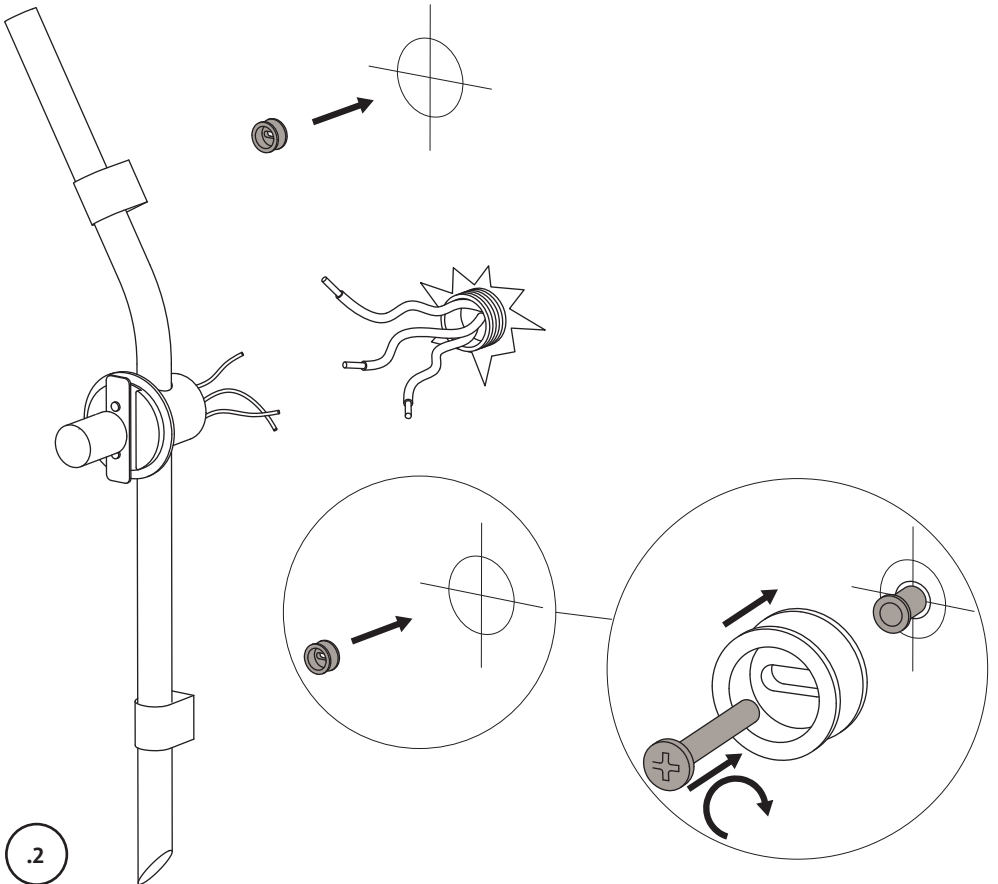

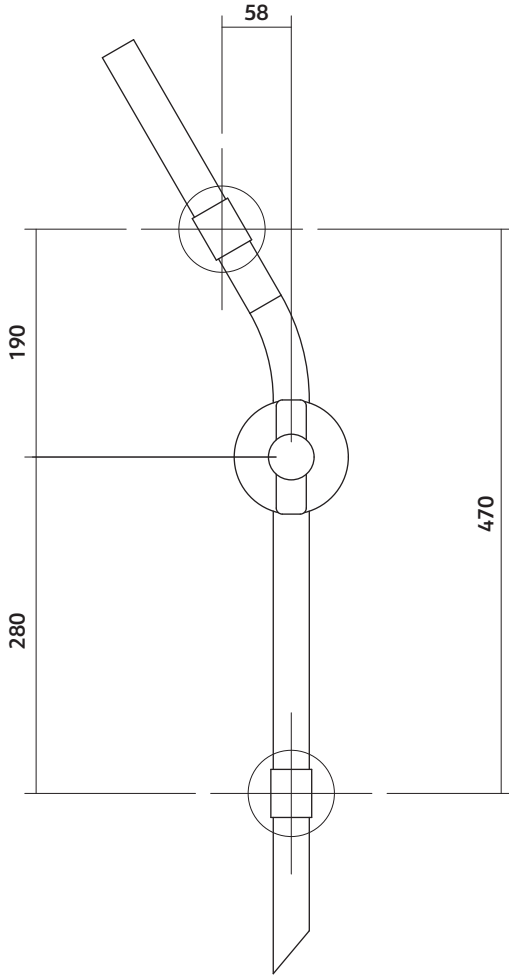
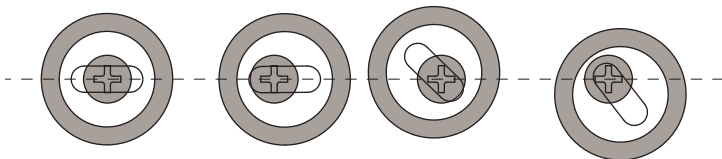

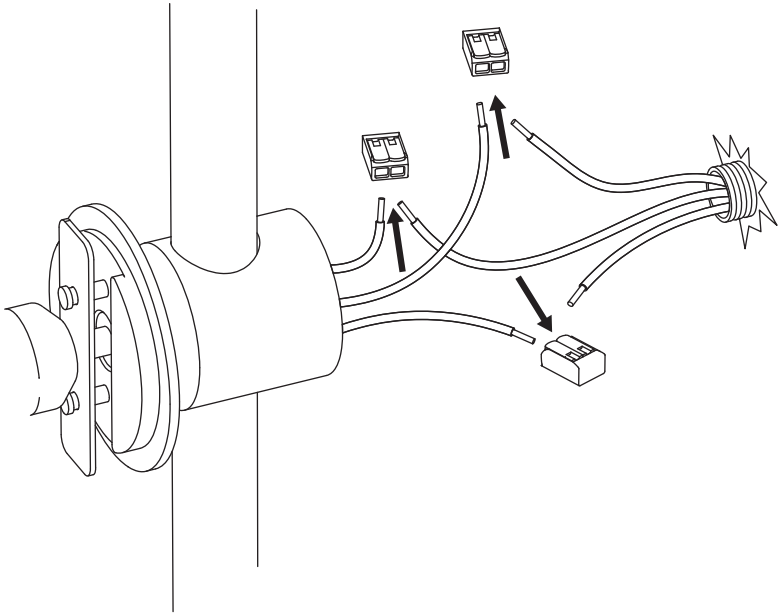

.4

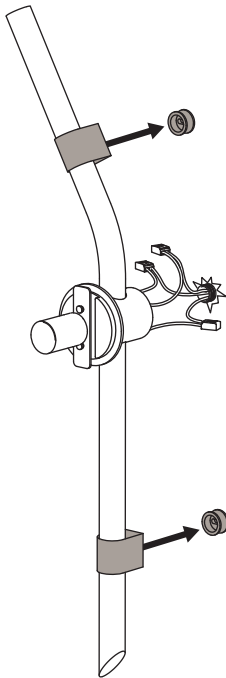

.5

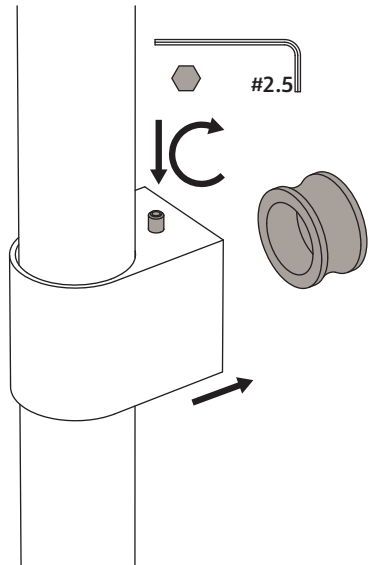

.6

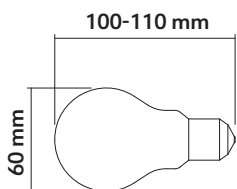
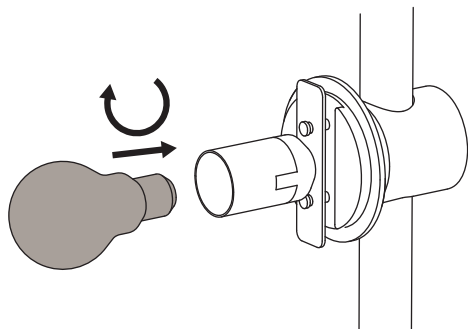

suggested bulb shape: A-19 / A-60

.7

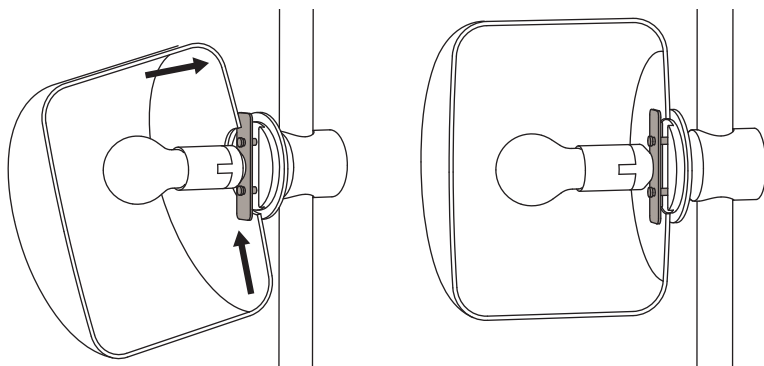

.8

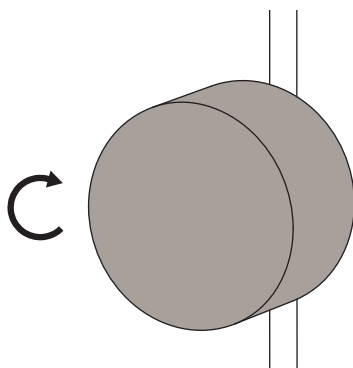

**BULBS, LAMPADINE, AMPOULES, LEUCHTENMITTEL, BOMBILLAS**  
fluo 1x20W E27 (E26 US)  or led 1x10W E27 (E26 US)  L max 105 mm  
Energy efficiency class from A++ to E

**FEEDING, ALIMENTAZIONE, ALIMENTATION, SPANNUNG, TENSION DE RED**  
220-240 / 120 V

