

KUNDALINI

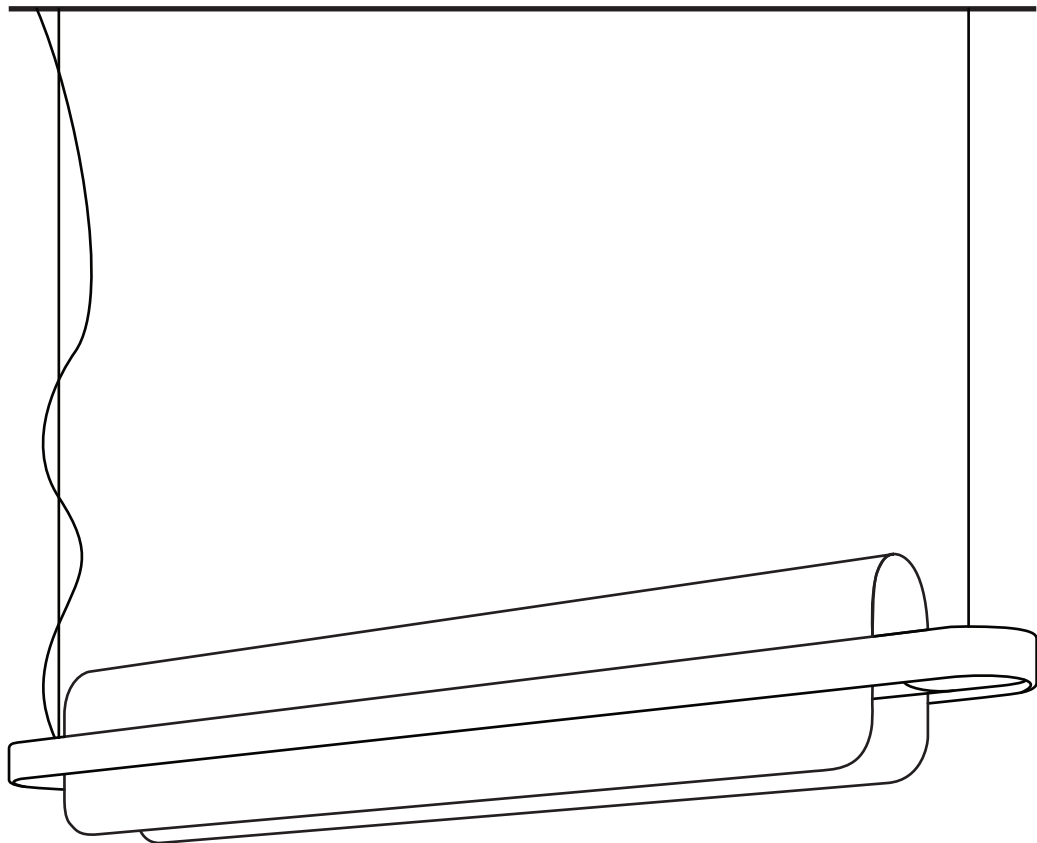

NAMI

A.Saggia & V. Sommella, 2017

**Istruzioni di montaggio
Assembly instructions
Montage-anleitung
Instrucciones de montaje
Instrucciones de montaje**



Classe I-Class I-Schutzklasse I-Classe I-Class I



IT-Attesta la conformità del prodotto alle disposizioni delle direttive comunitarie.

EN-It certifies the conformity of the product to the european community low voltage directive.

DE-Das Zeichen bestätigt die Übereinstimmung des Produkts mit den Bestimmungen der EU-Richtlinien.

FR-Il atteste la conformité du produit aux dispositions des directives communautaires.

ES-Certifica la conformidad del producto a las disposiciones de las normas de la comunidad.

IT-Attenzione, pericolo scossa elettrica

EN-Caution, risk of electric shock.

DE-Achtung, Stromschlaggefahr.

FR-Attention, risque de choc électrique.

ES-Atención, riesgo de descarga eléctrica.



IT-Il simbolo RAEE utilizzato per questo prodotto indica che quest'ultimo non può essere trattato come rifiuto domestico.

EN-The use of the WEEE symbol indicates that this product may not be treated as household waste.

DE-Durch Verwendung des WEEE-Symbols weisen wir darauf hin, dass dieses Produkt nicht als normaler Haushaltsmüll behandelt werden darf.

FR-L'utilisation du symbole WEEE indique que ce produit ne peut pas être traité comme déchet domestique.

ES-El símbolo RAEE en un producto indica que éste no se puede eliminar como cualquier otra basura.



ATTENZIONE

La sicurezza dell'apparecchio è garantita con l'uso appropriato delle seguenti istruzioni, pertanto è necessario conservarle. Togliere sempre la tensione prima di operare sull'apparecchio.

Per pulire la lampada non usare mai prodotti abrasivi o detergenti aggressivi.

Se il cavo esterno di questo apparecchio viene danneggiato, deve essere sostituito esclusivamente dal costruttore, dal suo servizio assistenza, o da personale qualificato equivalente, al fine di evitare pericoli.

Kundalini non effettuerà nessuna sostituzione se non dopo aver accertato la natura del difetto.

La sorgente luminosa di questo apparecchio deve essere sostituita esclusivamente dal produttore, dal suo servizio di assistenza o da personale qualificato equivalente.

WARNING

The safety is guaranteed by the appropriate use of the following instructions, so you must keep them.

Always disconnect the main voltage before working on the appliance.

Never use abrasive products or aggressive detergents for cleaning the lamp.

If the external cable of this appliance is damaged, it must be replaced by the manufacturer, its after sales service or other equivalent qualified person only in order to avoid any danger.

Kundalini will not provide a replacement until the nature of defect has been determined.

The light source must be replaced by the manufacturer, its after sales service or other equivalent qualified person only.

ACHTUNG

Die Sicherheit dieses Artikels wird nur durch die strikte Befolgung der nachfolgenden Betriebsanleitung gewährleistet. Bitte heben Sie diese unbedingt auf.

Vor allen Arbeiten ziehen Sie bitte den Stecker aus der Dose.

Für die Reinigung der Lampe niemals Schleifmittel oder aggressive Reinigungsmittel verwenden

Sollte das Außenkabel der Lampe beschädigt werden, ist es ausschließlich vom Service-Dienst des Herstellers oder gleichwertigen, qualifiziertem Personal auszutauschen, um somit Gefahren zu vermeiden.

Kundalini leistet grundsätzlich erst nach einer gründlichen Überprüfung Ersatz.

Die Lichtquelle darf nur von der i Service-Dienst des Herstellers oder gleichwertigen, qualifiziertem Personal auszutauschen.

ATTENTION

La sûreté de l'appareil n'est garantie qu'en suivant scrupuleusement les instructions ci-après. Il est donc nécessaire de les conserver.

Isoler l'appareil du secteur avant toute manipulation.

Pour nettoyer la lampe, ne jamais utiliser de produits abrasifs ou de nettoyeurs agressifs.

Si le câble externe de cet appareil est endommagé, il doit être remplacé uniquement par les soins du constructeur, par son service après-vente ou bien par le personnel équivalent, et ce afin d'éviter tout danger.

Kundalini ne remplacera aucun appareil sans en avoir pu vérifier le défaut.

La source lumineuse doit être remplacée uniquement par les soins du constructeur, par son service après-vente ou bien par le personnel équivalent.

ATENCIÓN

La seguridad del aparato está garantizada sólo con el uso apropiado de las instrucciones siguientes, por lo tanto es necesario atenderlas puntualmente.

Desconectar siempre la alimentación antes de trabajar en el aparato.

Nunca utilice productos abrasivos o detergentes agresivos para limpiar la lámpara.

Si el cable externo de este aparato se deteriora será necesario sustituirlo; la sustitución podrá efectuarla exclusivamente el fabricante, su servicio de asistencia o personal cualificado equivalente para evitar peligros.

BOX 1

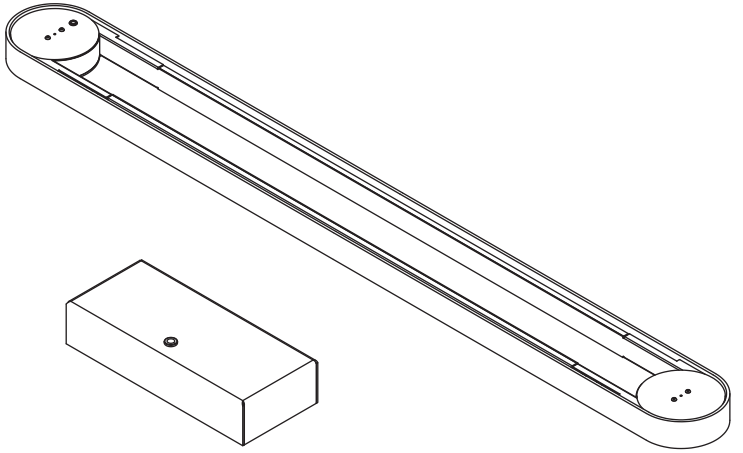

1x

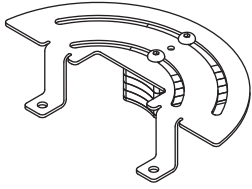

1x

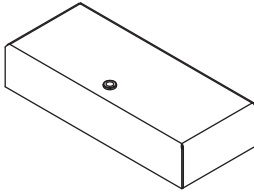

1x

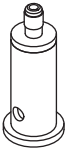

2x



4x



1x #3

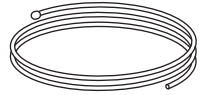

2x

BOX 2

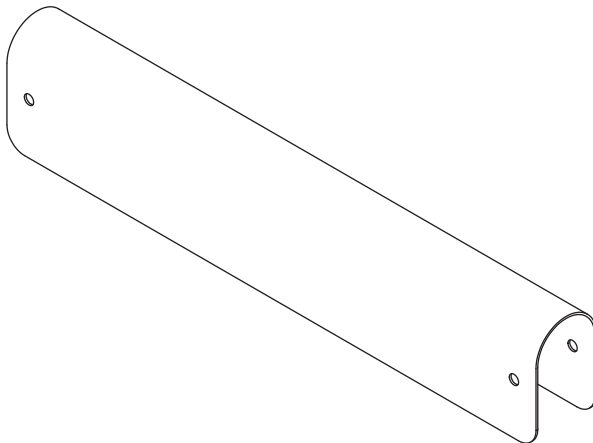

1x

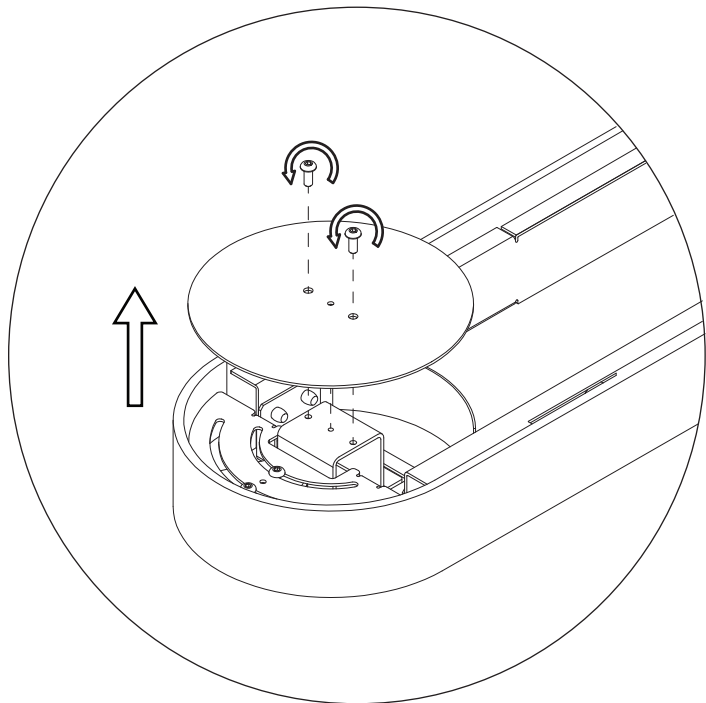
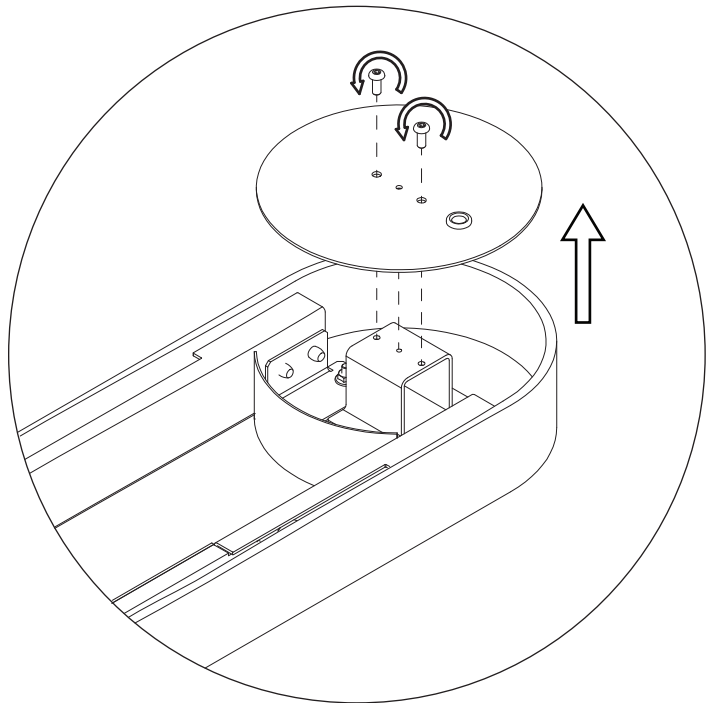
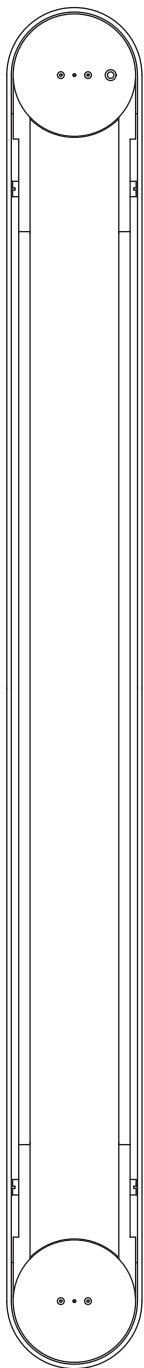

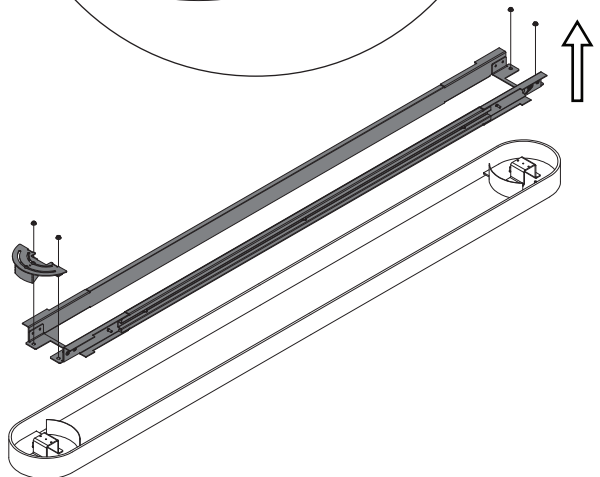
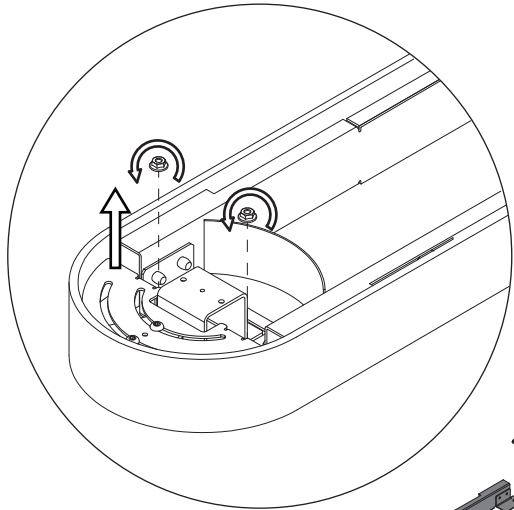
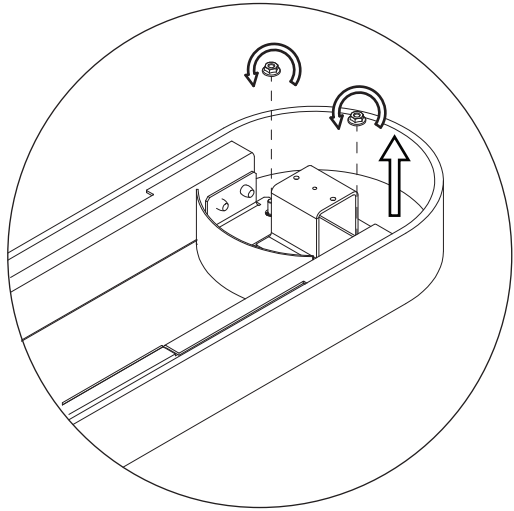
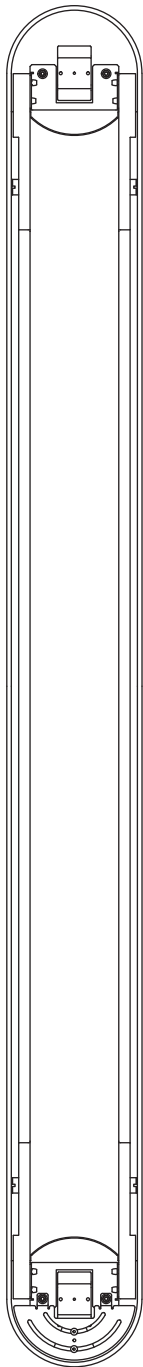

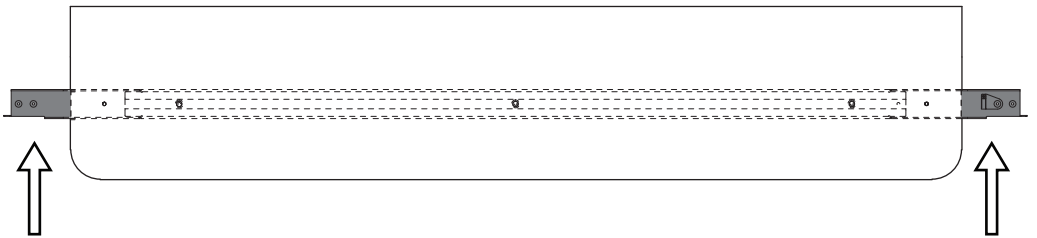
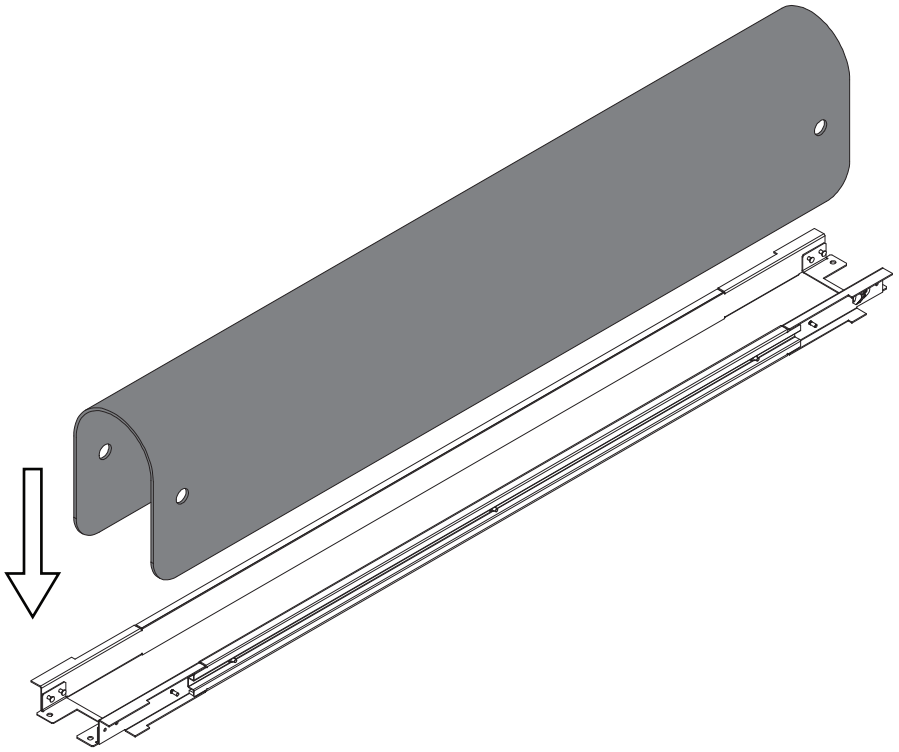

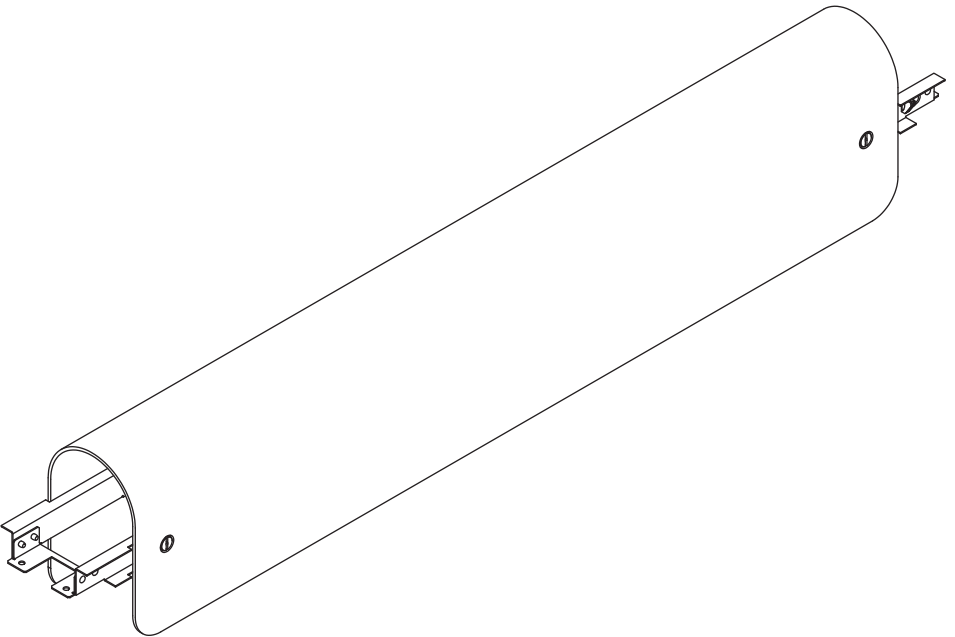
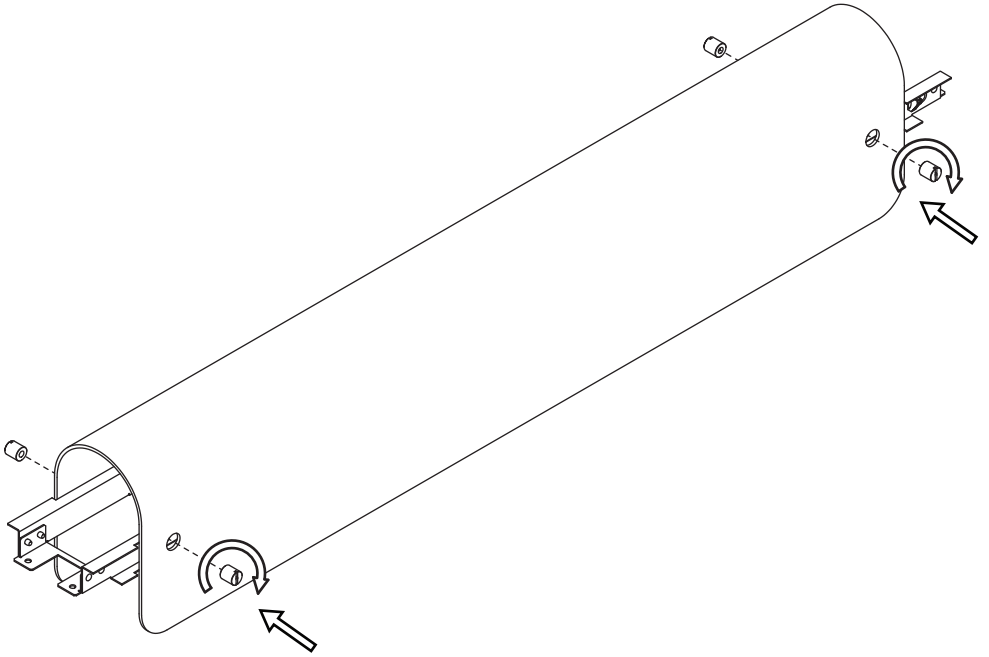

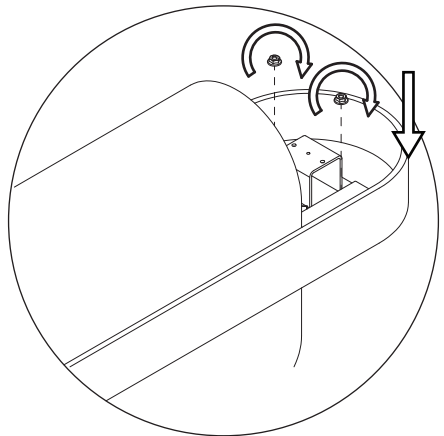
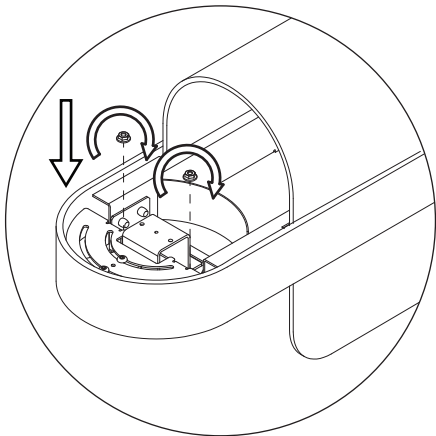
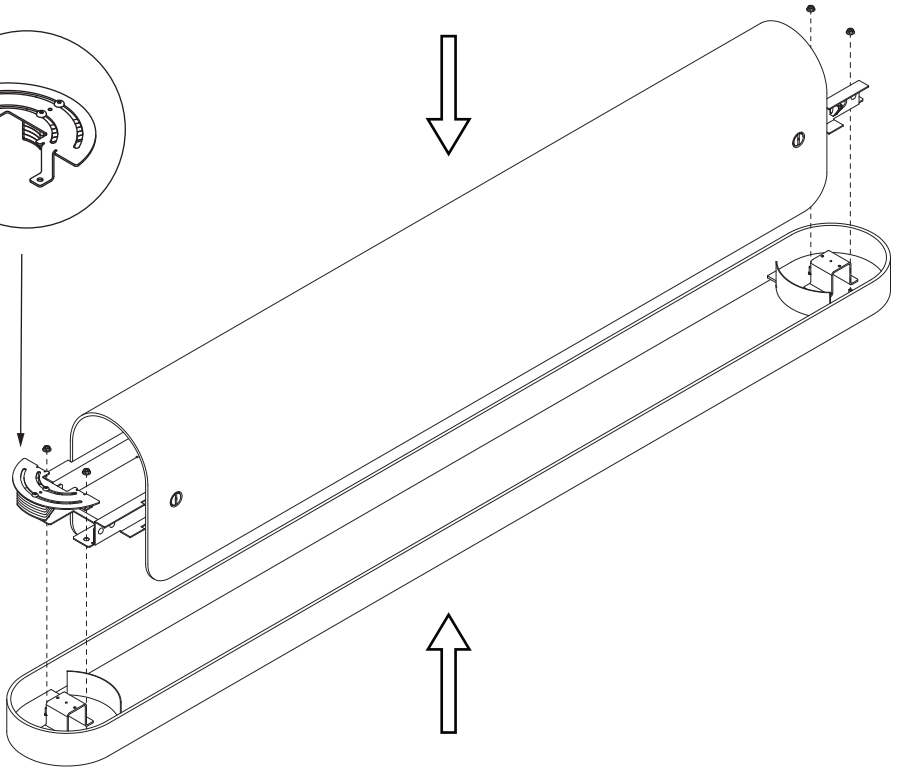

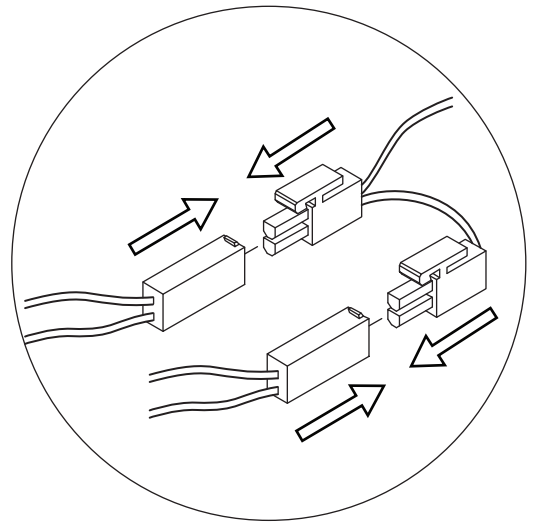
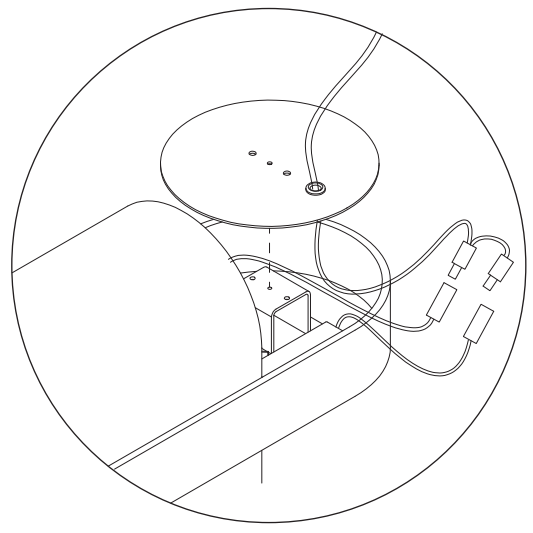
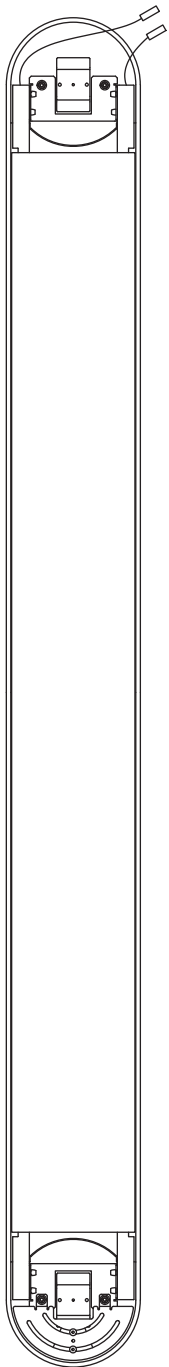

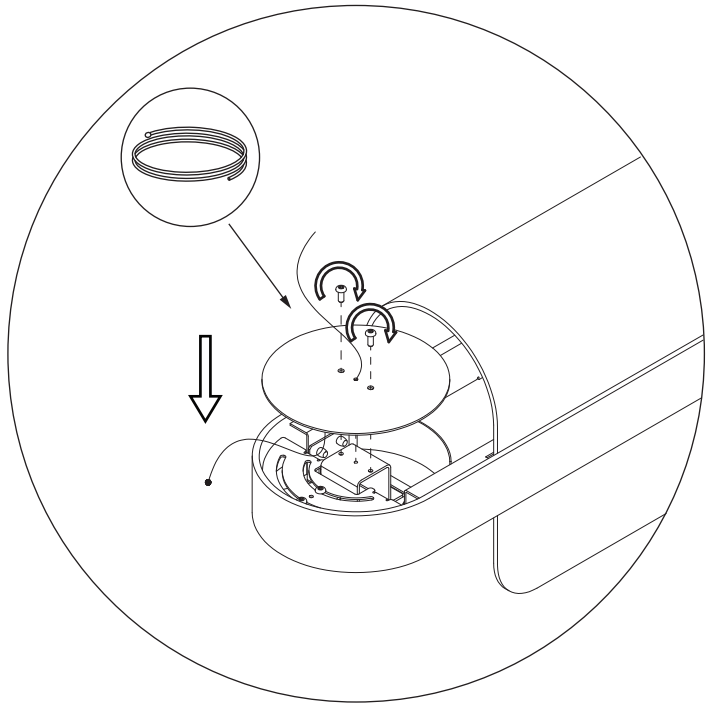
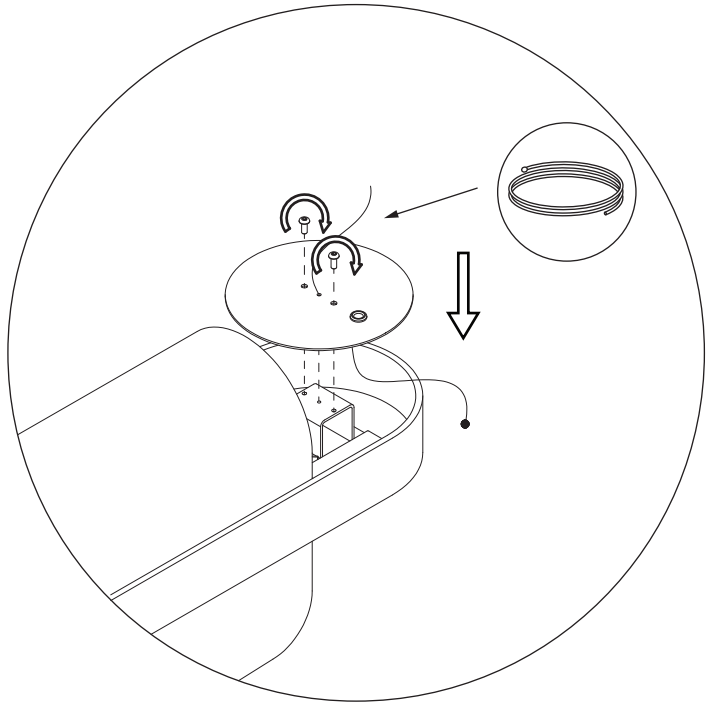
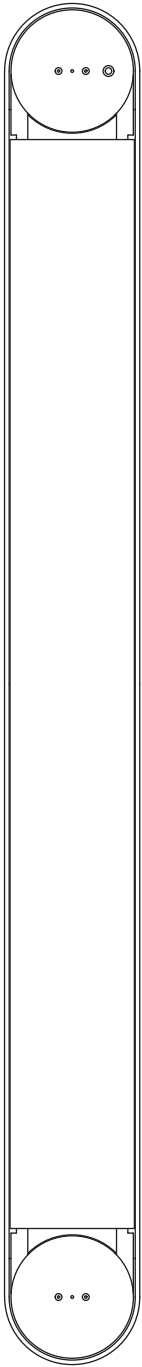

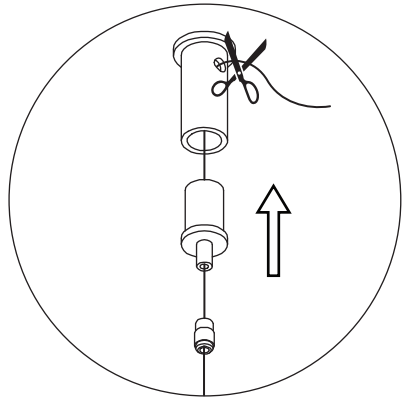
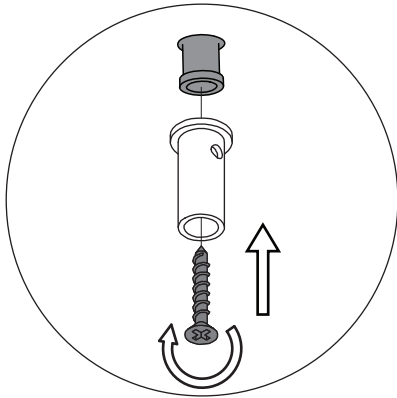
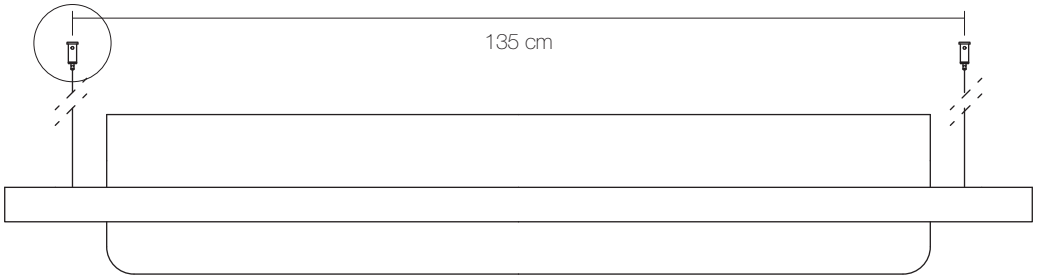

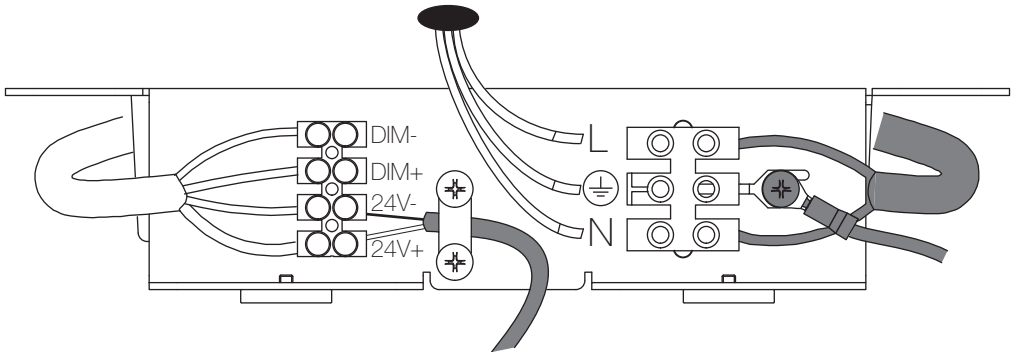
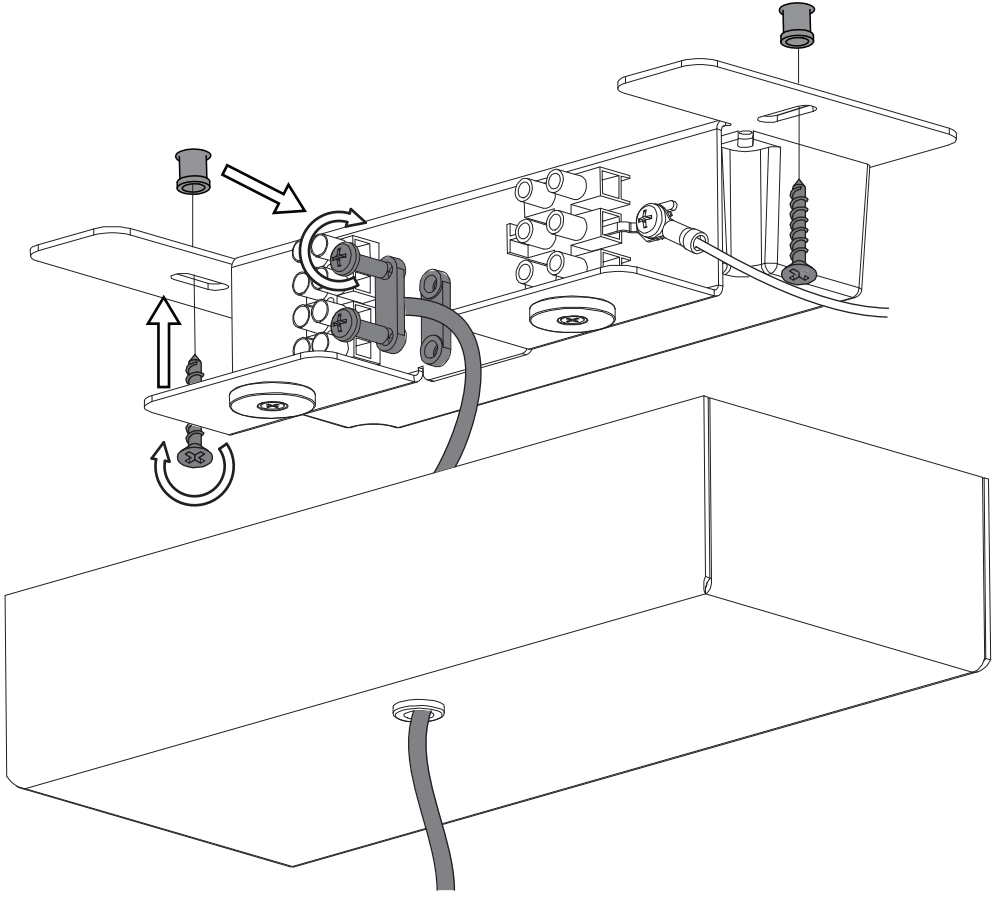

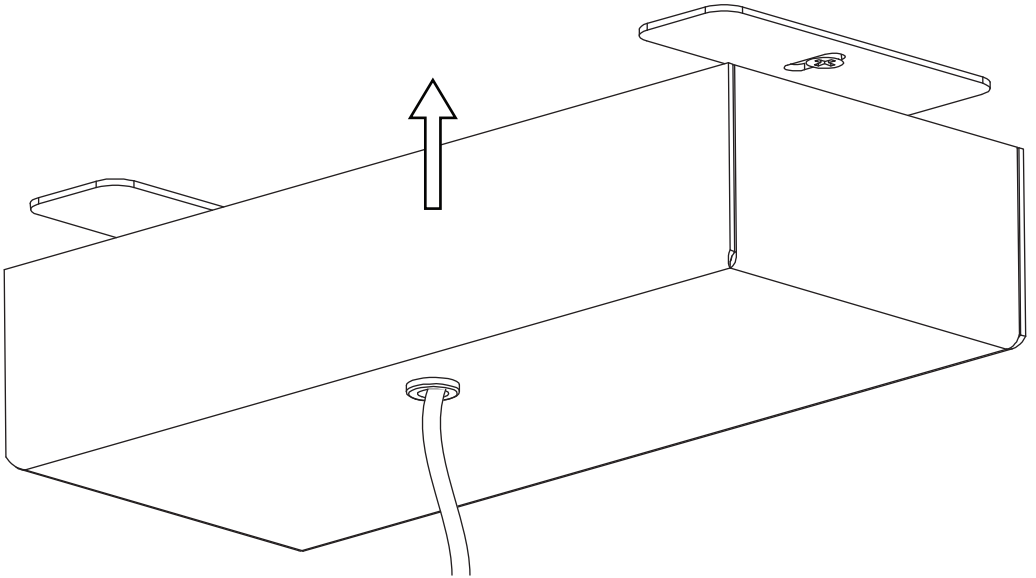

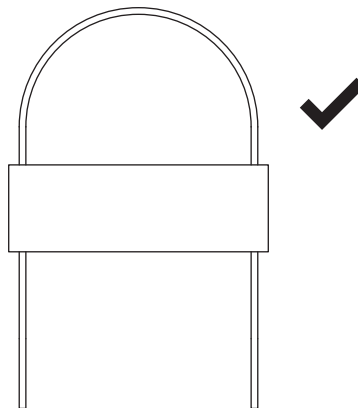
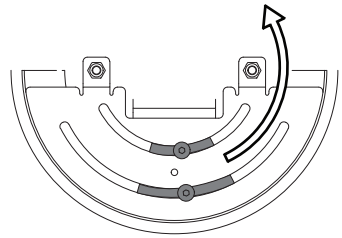
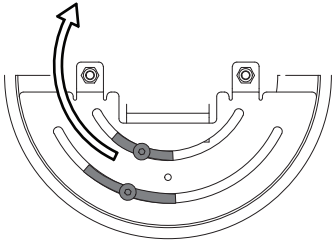
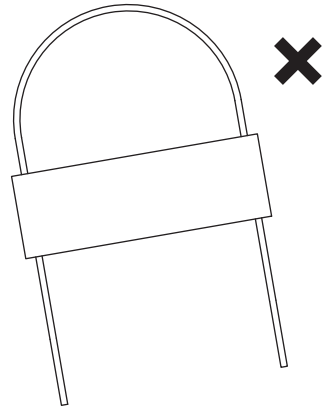
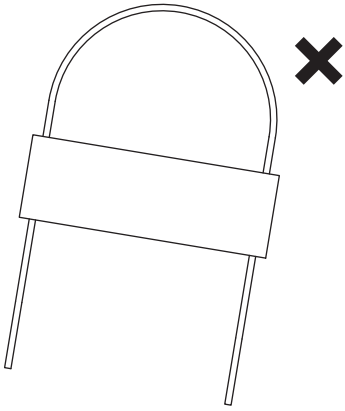

ISTRUZIONI DI MONTAGGIO

Togliere la tensione di rete. Inserire il cavo di alimentazione della lampada nel rosone. Bloccare il cavo attraverso il bloccacavo. Fissare il rosone utilizzando viti e tasselli idonei alle caratteristiche del soffitto. Collegare i cavi di alimentazione provenienti dalla rete alle morsettiere. Collegare il cavo di terra (colore giallo-verde) all'apposito dispositivo.

Dimmer

Collegare i cavi del dimmer negli ingressi preposti della morsettiere, contrassegnata dall'etichetta "dim + dim -". La lampada accetta esclusivamente segnale dimmer di tipo 1-10V o 10V PWM. Note: impostando il dimmer al minimo la lampada non viene spenta. Per spegnere la lampada inserire un interruttore ON-OFF sul cavo di Linea.

ASSEMBLY INSTRUCTIONS

Disconnect the mains voltage supply. Plug the power cable of the lamp to the canopy. Lock the cable screwing the cable clamp. Fix canopy using screws and Fischer screws suited to the ceiling characteristics. Connect the power leads from the grid to the terminal board. Connect the earth wire (colour yellow-green) to the specific device.

Dimmer

Connect the dimmer cables to the inputs of the terminal board, labeled with the label "dim + dim -". The lamp only accepts 1-10V or 10V PWM dimmer signal. Note: If the dimmer is set to the minimum, the lamp will not turn off. To turn off the lamp, insert an ON-OFF switch on the line cable.

MONTAGE-ANLEITUNG

Die Netzspannung abschalten. Das Versorgungskabel der Lampe in die Rosette einführen. Das Kabel mit dem Kabelstopper arretieren. Die Rosette befestigen, dabei für die jeweilige Decke geeignete Schrauben und Dübel verwenden. Die von dem Versorgungsnetz kommenden Versorgungskabel an die Klemmen. Den Erdungskabel (gelb-grün) an die entsprechende Vorrichtung anschließen.

Dimmer

Schließen Sie die Dimmerkabel an die Eingänge von Anschluss, an, welche mit dem Verweis „dim + dim -“, gekennzeichnet sind. Die Leuchte akzeptiert nur 1-10V oder 10V PWM Signale. Hinweis: Auch wenn der Dimmer auf das Maximum seiner Leistung geschaltet ist, schaltet sich die Leuchte nicht aus. Um die Leuchte auszuschalten muss ein Ein/Aus Knopf angebracht werden.

INSTRUCTIONS DE MONTAGE

Couper le courant. Insérer le câble d'alimentation de la lampe dans la rosace. Bloquer le câble au moyen du bloque-câble. Fixer la rosace en utilisant des vis et chevilles adaptées aux caractéristiques du plafond. Relier les câbles d'alimentation provenant du circuit électrique aux bornes. Relier le câble de terre (couleur jaune-vert) au dispositif prévu.

Dimmer

Connecter les câbles du variateur dans les entrées des bornes, marqué par l'étiquette « dim + dim - ». La lampe accepte uniquement le signal dimmer de type 1-10V ou 10V PWM. Notes: en réglant la luminosité au minimum la lampe ne s'éteint pas. Pour éteindre la lampe insérer un interrupteur marche-arrêt sur la ligne de câble.

INSTRUCCIONES DE MONTAJE

Quitar la tensión de red. Insertar el cable de alimentación de la lámpara en el plafón. Bloquear los cables por medio del bloqueador de cables. Fijar el plafón utilizando tornillos apropiados para las características del techo. Conectar los cables de alimentación procedentes de la red a las borneras. Conectar el cable de tierra (color amarillo-verde) al dispositivo correspondiente.

Dimmer

Para conectar los cables del dimmer en las entradas del terminal, marcado por la etiqueta "dim + dim -". La lámpara sólo acepta señal dimmer de tipo 1-10V o PWM 10V. Notas: ajustando el dimmer al mínimo la lámpara no se apaga. Para apagar la lámpara insertar un interruptor ON-OFF en el cable de línea.

LAMPADINE-BULBS-LEUCHTENMITTEL-AMPOULES-BOMBILLAS:

board led 4 x 15W
2700 K - 2520x2 lm - CRI>80

Energy efficiency class A+

ALIMENTAZIONE-FEEDING-SPANNUNG-ALIMENTATION-TENSION DE RED:

100-240 V

KUNDALINI SRL

I-20090 Trezzano sul Naviglio - Milano

Viale Leonardo da Vinci, 277

phone +39 02 3653 8950

fax +39 02 3653 8964

www.kundalini.it

info@kundalini.it

JOIN OUR COMMUNITY



[kundalini.lighting](https://www.facebook.com/kundalini.lighting)



[kundalini_lighting](https://www.instagram.com/kundalini_lighting)
