

# Penna Sconce 16 and 40

## Installation Instructions

cerno®

### General Product Information



This product is suitable for damp locations.

This product is to be installed to a standard 4" junction box with 3" round plaster ring or an octagon junction box.



### CAUTION - RISK OF FIRE



This product requires installation by a qualified electrician. Before installing be sure to read all instructions and **TURN POWER OFF TO THE JUNCTION BOX**

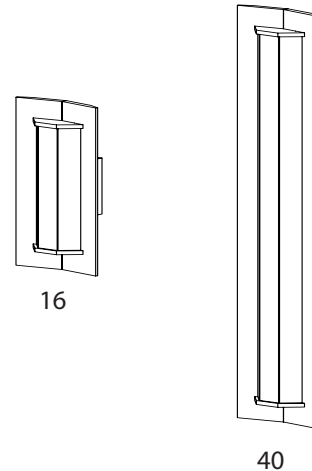

### Electrical Connections

- 1 Screw the mounting plate onto the junction box using the #8-32X3/4" machine screws.
- 2 Pull the line voltage wires through the center hole in the mounting plate. Use wire nuts to make connections between line voltage wires and the driver.
- 3 (Optional) If 0-10V dimming control is to be used, connect purple and grey LED Driver leads to leads from remote 0-10V dimmer.

### CRITICAL NOTE:

If 0-10V dimming is not being used, the tinned ends of the purple and grey LED Driver leads should be snipped off and these leads should be capped individually such that they remain isolated from one another.

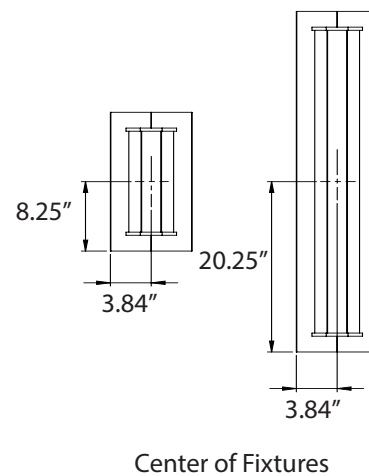

Center of Fixtures

### Dimming Notes

Input Voltage	Dimming Modes
120 VAC	Triac, ELV, or 0-10V
240 VAC	0-10V only
277 VAC	0-10V only

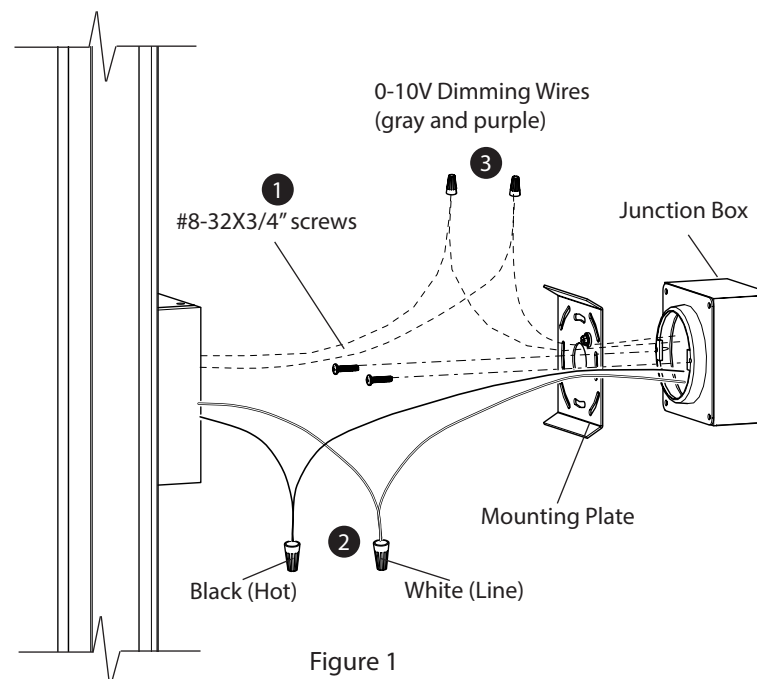
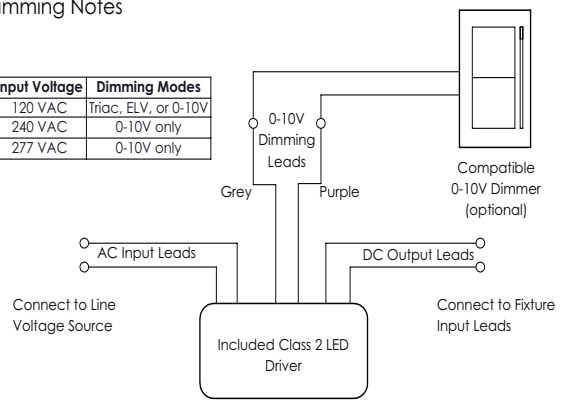

Figure 1

## Mounting the Fixture

- 4 Align the fixture with the mounting plate. Use the provided 1/8" allen key to tighten the set screws and mount the fixture onto the mounting plate.

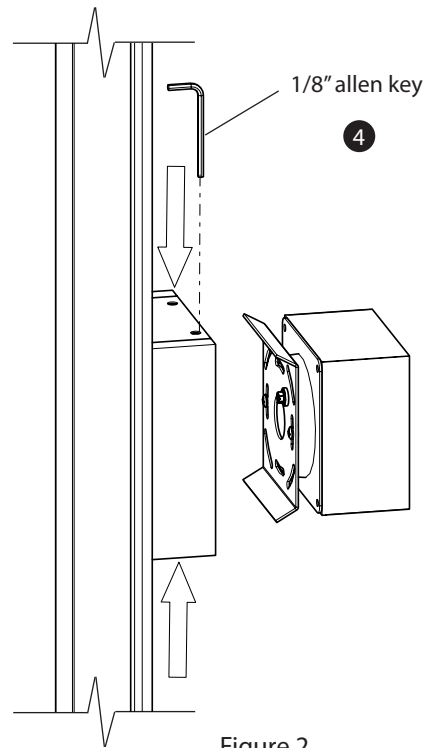

Figure 2