

General Product Information



This product is suitable for damp locations.

This product is to be installed to a standard 4" junction box with 3" round plaster ring or an octagon junction box.



CAUTION - RISK OF FIRE



This product requires installation by a qualified electrician. Before installing be sure to read all instructions and **TURN POWER OFF TO THE JUNCTION BOX**

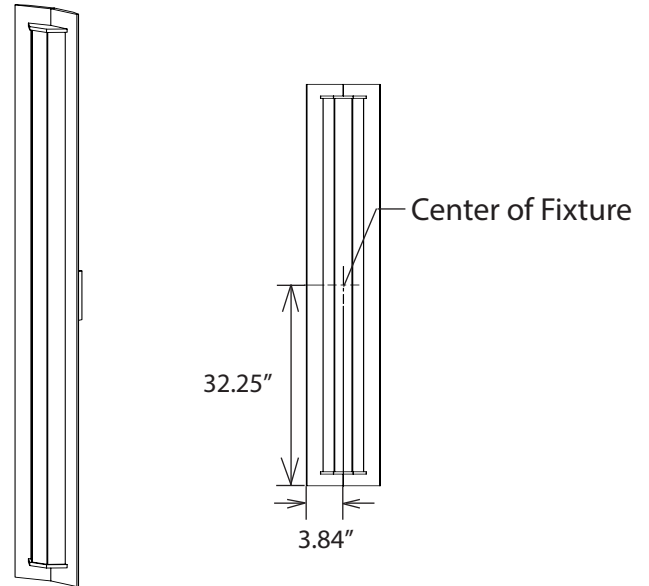

Adjusting the Fixture Height

- 1 Strike a vertical line going along the center of the junction box. Screw the mounting blocks 24in below and above the center of the junction box.

WARNING

The included anchors are supplied only as a convenience. It is the responsibility of the installer to verify that the installation conditions and hardware used are suitable for supporting the load of the fixture.

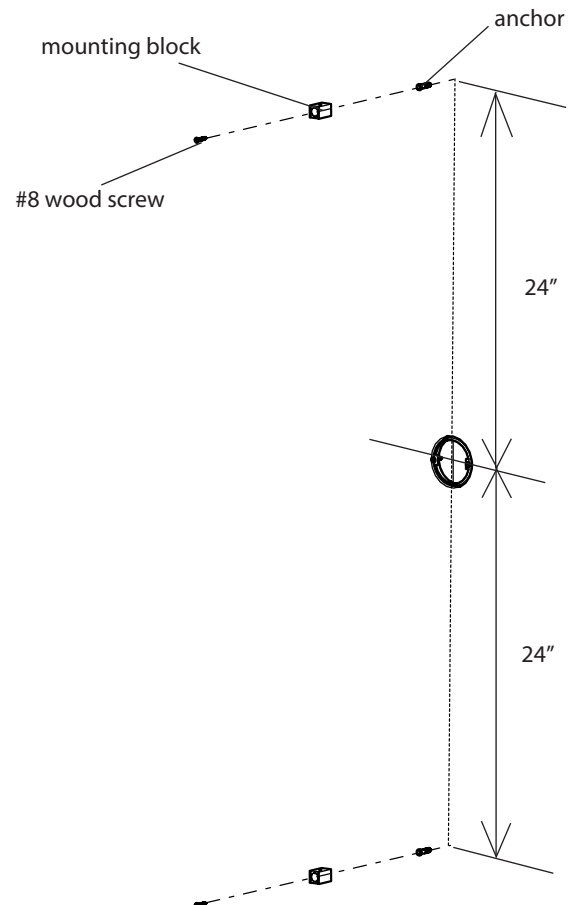

Figure 1

Electrical Connections

- 2 Screw the mounting plate onto the junction box using the #8-32X3/4" machine screws.
- 3 Pull the line voltage wires through the center hole in the mounting plate. Use wire nuts to make connections between line voltage wires and the driver.
- 4 (Optional) If 0-10V dimming control is to be used, connect purple and grey LED Driver leads to leads from remote 0-10V dimmer.

CRITICAL NOTE:

If 0-10V dimming is not being used, the tinned ends of the purple and grey LED Driver leads should be snipped off and these leads should be capped individually such that they remain isolated from one another.

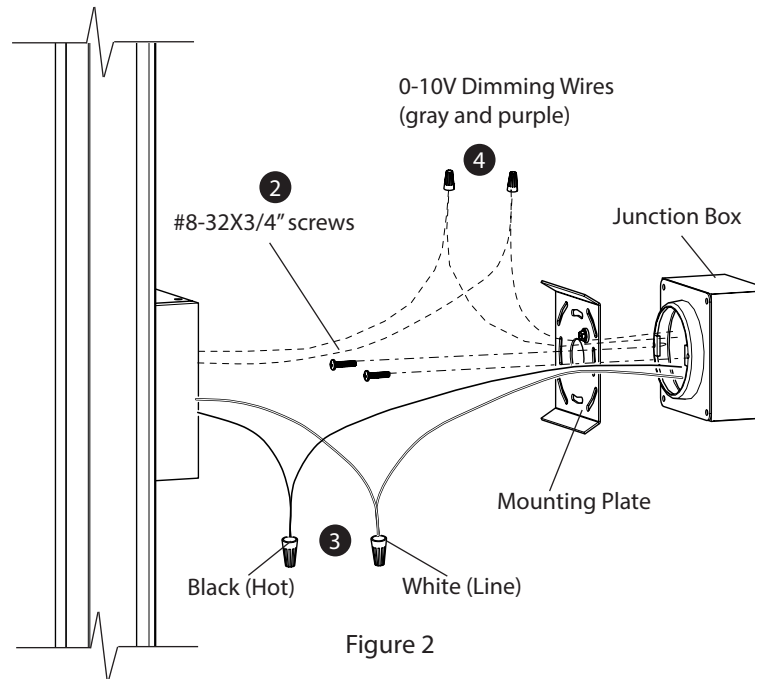
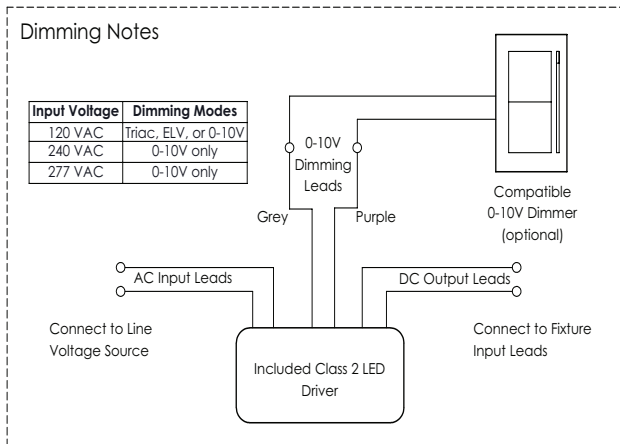

Figure 2

Mounting the Fixture

- 5 Use the provided 5/64" allen key for the set screws on both mounting blocks.
- 6 Use the provided 1/8" allen key to tighten the set screws and mount the fixture onto the mounting plate.

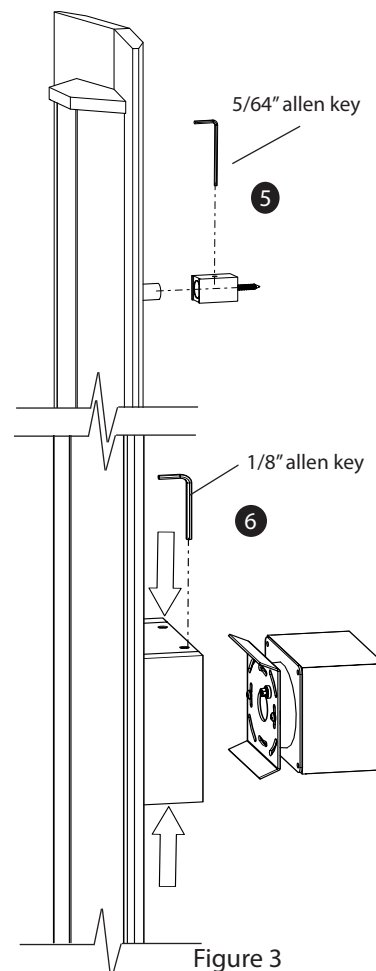

Figure 3