

Date \_\_\_\_\_

Name \_\_\_\_\_

Client \_\_\_\_\_

Project name \_\_\_\_\_

Quote# \_\_\_\_\_

Type/Quantity \_\_\_\_\_

**Listings**

Specification Sheet

**WALKER II S 40 927**  
**6 22621 9200**

[Weblink](#)

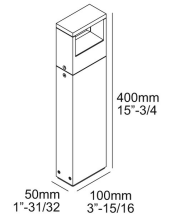
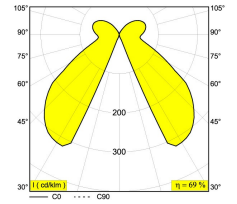

Available colors: ALU GREY-DARK GREY (6 22621 9200 A-N)  
 DARK GREY-GOLD COLORED (6 22621 9200 N-GC)

LED CLUSTER 5,2W / CRI>90 / 2700K / 630lm  
 INCL.LED POWER SUPPLY 350mA-DC

LED Technics: Light source: 630 lm // 5 W // 121 lm/W  
 Luminaire: 433 lm // 5 W // 72 lm/W

120V / 60Hz

Class 2 N.a.  
 Ada N.a.

Weight: 3.7 LBS  
 Protection level: IP54 - suitable for wet locations  
 Minimum distance: n.a.

Options: PIN 17  
 JUNCTION BOX  
 IP68 CONNECTOR 3P

For detailed installation instructions, please consult the manual. [22621\\_XXX0\\_HAND.pdf](#)

**WALKER II S 40 927**  
**6 22621 9200**

**Related references**

**WATERPROOF CONNECTION PARTS**

[Weblink / Specsheet](#)

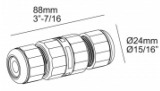

IP68 CONNECTOR 3P  
6 216 12 02

[Weblink / Specsheet](#)

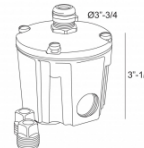

JUNCTION BOX  
6 216 12 00

**Related references**

**PINS AND PLATES FOR BOLLARDS**

[Weblink / Specsheet](#)

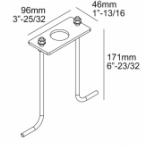

PIN 17  
15222 0170

WALKER II S 40 927  
6 22621 9200

Related project picture of product family:

