

SCHONBEK
Signature[™]

Embrace
S4844- __ __ O

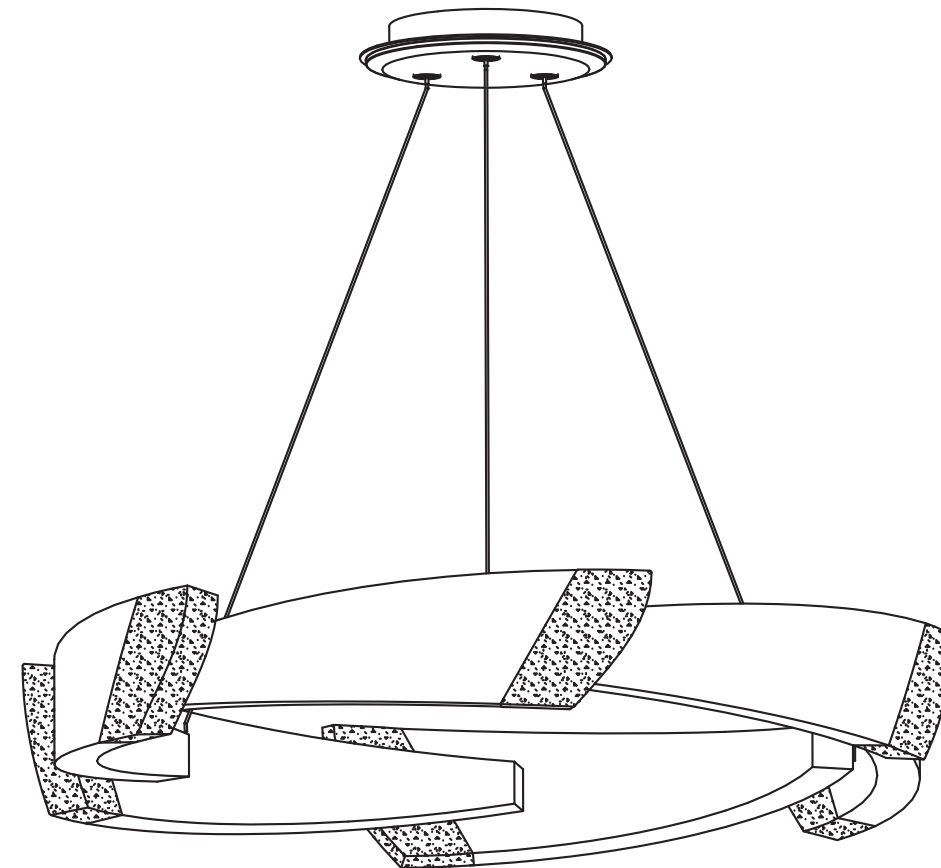

THIS DESIGN IS THE PROPRIETARY
TRADE DRESS/TRADEMARK OF
W SCHONBEK LLC.

SCHONBEK
Signature[™]

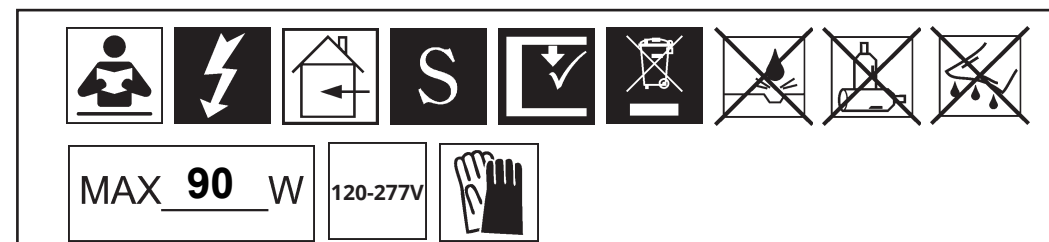

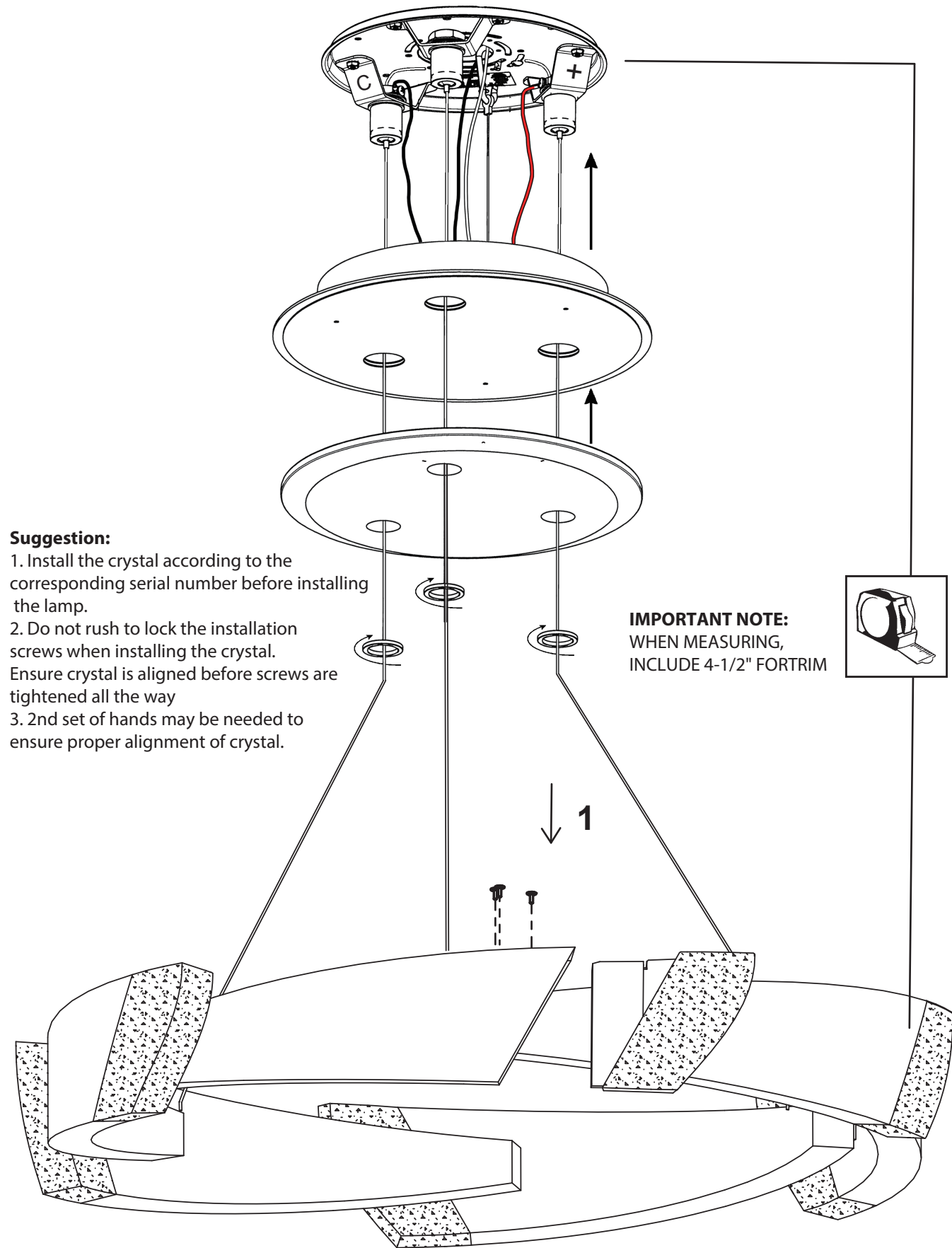

Suggestion:

1. Install the crystal according to the corresponding serial number before installing the lamp.
2. Do not rush to lock the installation screws when installing the crystal. Ensure crystal is aligned before screws are tightened all the way
3. 2nd set of hands may be needed to ensure proper alignment of crystal.

IMPORTANT NOTE:
WHEN MEASURING,
INCLUDE 4-1/2" FORTRIM



10

