

Ceiling Canopy (Compact Fluorescent & LED)

CKDCF | 1.3



GENERAL PRODUCT INFORMATION:



These fixtures are intended to be installed utilizing NEC compliant junction boxes.

This product is suitable for damp locations.

CAUTION - RISK OF FIRE
 This product must be installed in accordance with the applicable installation code by a person familiar with the construction and operation of the product and the hazards involved.
 Use minimum 90°C supply conductors.

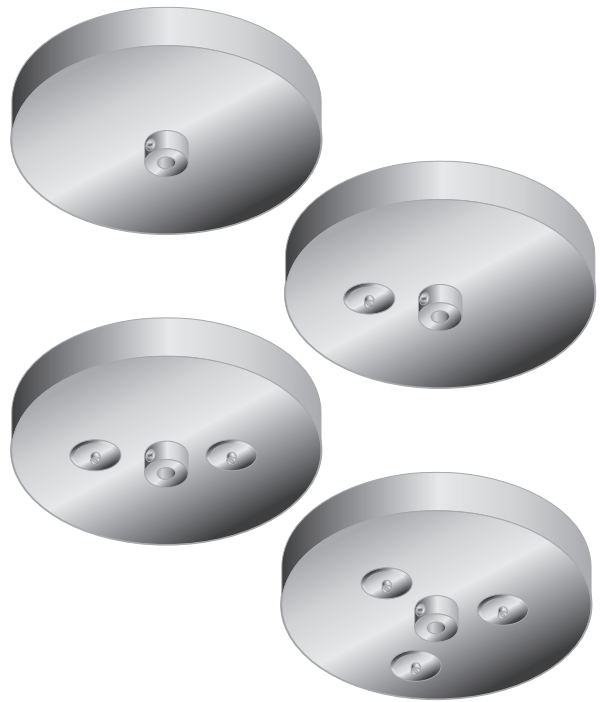

Preparing the Canopy

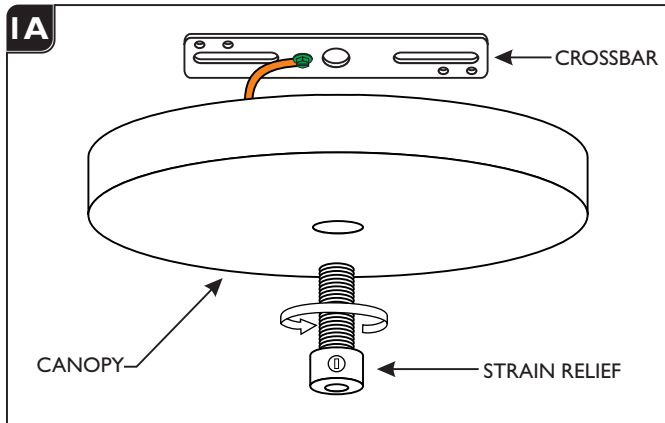

1 Remove the crossbar from the canopy by completely unscrewing the strain relief.

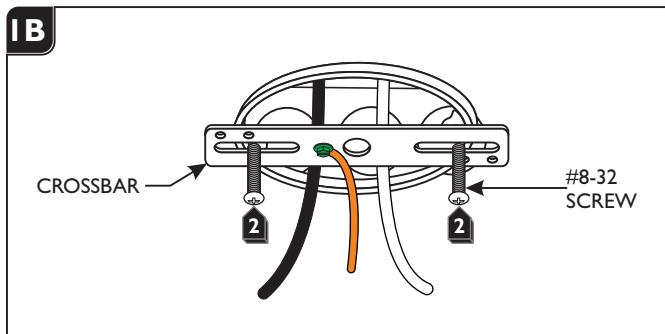

2 Mount the crossbar assembly to the electrical box with the two provided #8-32 screws.

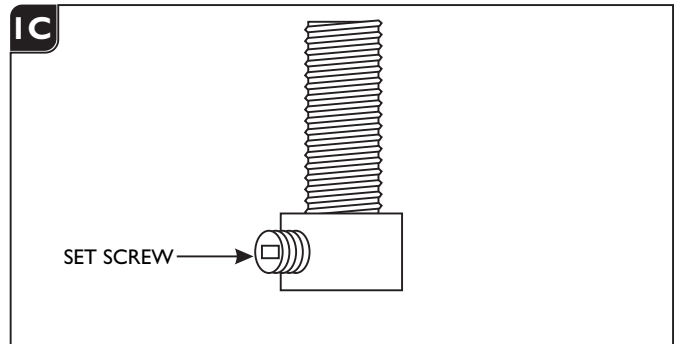

3 Loosen (**Do Not Remove**) the set screw on the strain relief.

Install the Fixture (No Suspension Cables)

Note: For canopies with suspension cables, skip section 2 and continue on section 3.

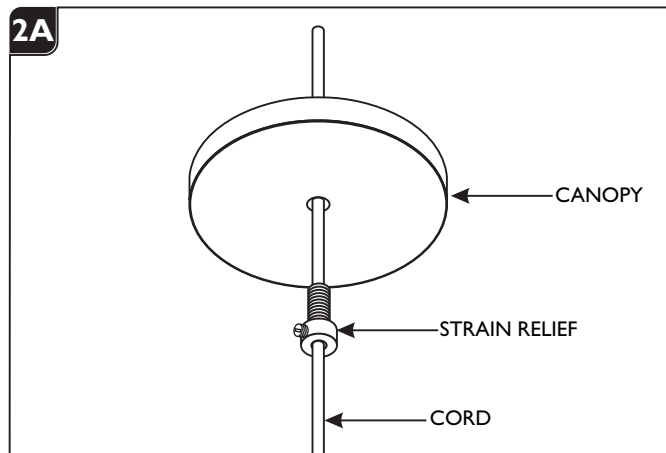

- 1 Feed the cord through the primary strain relief and the canopy.

Note: If the fixture has a cord with a cloth cover, taping down the frayed end of the cloth may assist in feeding it through the strain relief.

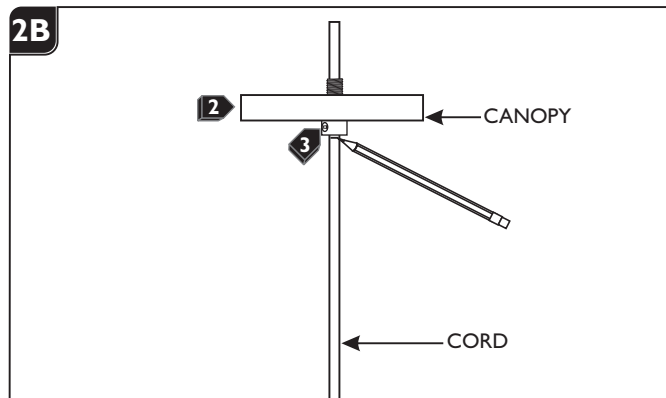

- 2 Adjust the fixture height (from bottom of the fixture shade to top of the canopy) by moving the canopy and strain relief up or down.
- 3 When the desired height is achieved, tighten the set screw on the strain relief.
- 4 Mark the cord underneath the strain relief.
- 5 Move on to section 4.

Install the fixture (With Suspension Cables)

NOTE: Make sure to support the fixture while adjusting the aircraft cables. An assistant is recommended to complete the remaining steps.

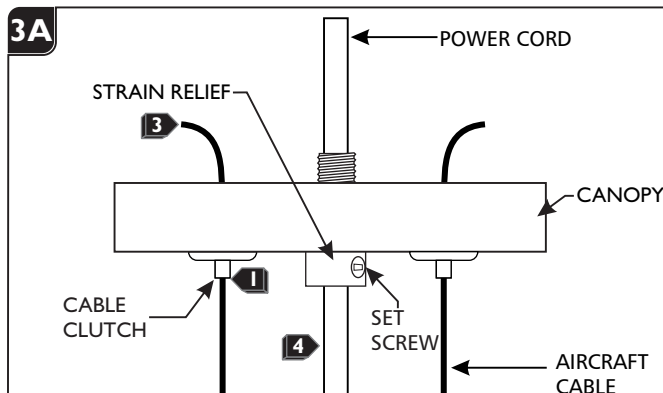

- 1 Feed the aircraft cable(s) through the cable clutch in the canopy.
- 2 Evenly pull the aircraft cable up through the canopy to raise the fixture to the desired length.
- 3 Cut off the excess aircraft cable leaving enough for fine leveling later.
- 4 If necessary loosen the set screw in the strain relief and feed the power cord from the fixture into the canopy port.

Note: If the fixture has a cord with a cloth cover, taping down the frayed end of the cloth may assist in feeding it through the strain relief.

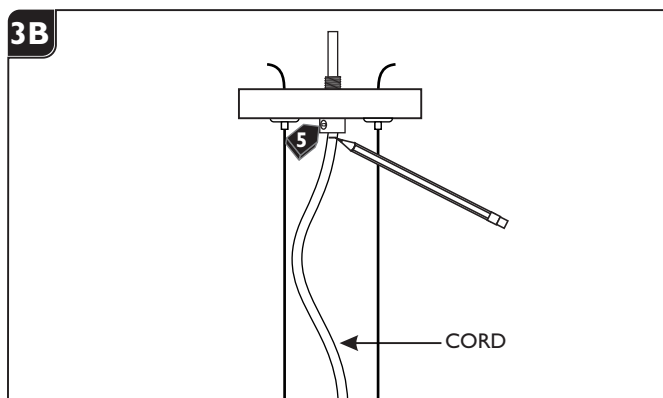

NOTE: The power cord does not support the fixture. For a casual "lazy cord" look, cut the power cord several inches longer than the drop height of the fixture.

- 5 Once the desired look is determined, tighten the set screw on the strain relief.
- 6 Mark the cord underneath the strain relief.

Install the Canopy

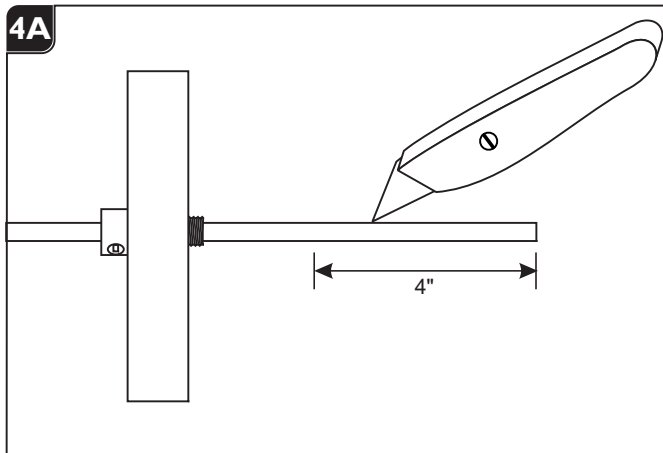

- 1 Leave 6" of the cord behind the canopy for power connections. Cut the excess cord.
- 2 From the end of the cord, strip the insulation 4" using a sharp knife. **Make sure not to nick the inner wires.**
- 3 Strip the end of the wires.

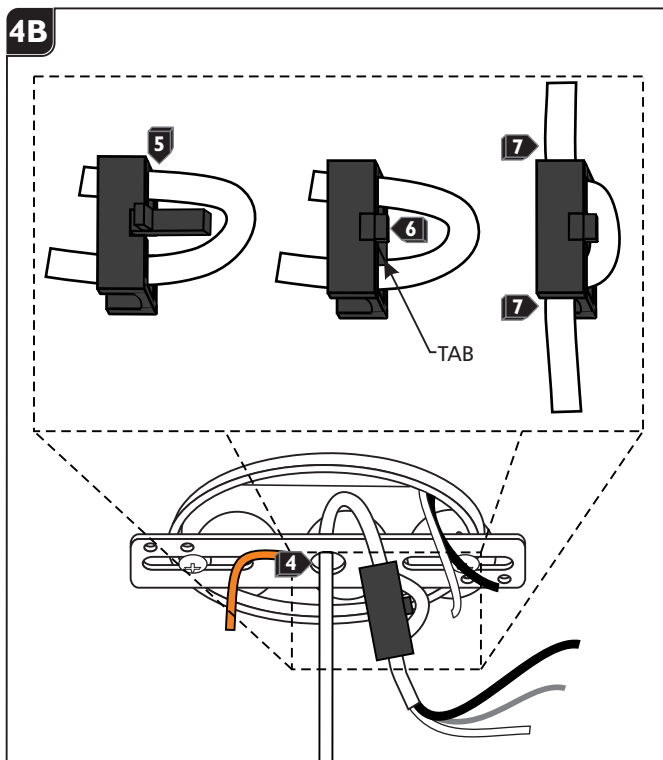

- 4 Feed the fixture wires through the crossbar center hole and then pull them out of the electrical box. **Note:** If the cord has a cloth cover, peel back or remove the cloth where the secondary strain relief is installed.
- 5 Install the secondary strain relief by first feeding the power cord through it.
- 6 Snap the strain relief tab into place.
- 7 Pull the cord to take up the slack and fit the rest of the cord in the strain relief's openings.

Connect the Power (Compact Fluorescent)

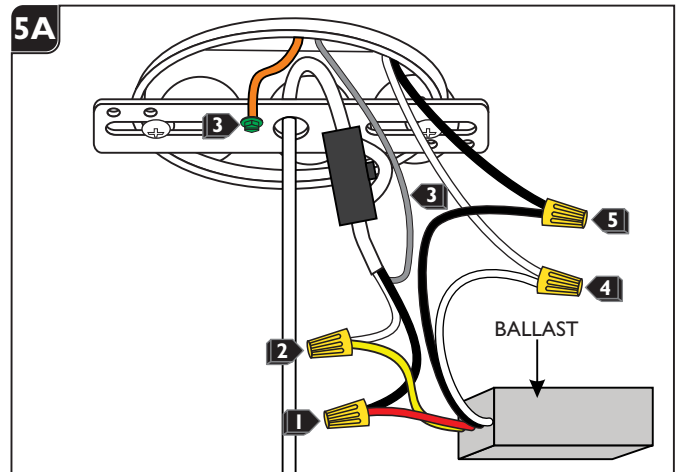

- 1 Connect the red ballast wire to one of the insulated pendant wires with a wire nut.
- 2 Connect the yellow ballast to the other insulated pendant wire with a wire nut.
- 3 Connect the fixture and the crossbar ground wire to a suitable ground in accordance with local electrical codes.
- 4 Connect the white ballast wire to the neutral power line wire with a wire nut.
- 5 Connect the black ballast wire to the hot power line wire with a wire nut. **Skip to section 7A**

Connect the Power (LED)

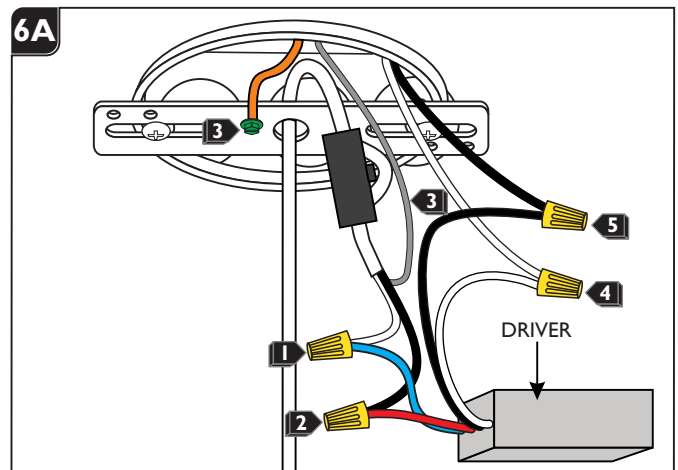

- 1 Connect the negative driver wire (labeled -) to the pendant wire with white tracer (white wire) with a wire nut.
- 2 Connect the positive driver wire (labeled +) to the remaining pendant wire (black wire) with a wire nut.
- 3 Connect the fixture and the crossbar ground wire to a suitable ground in accordance with local electrical codes.
- 4 Connect the white driver wire to the neutral power line wire with a wire nut.
- 5 Connect the black driver wire to the hot power line wire with a wire nut.

Complete Installation

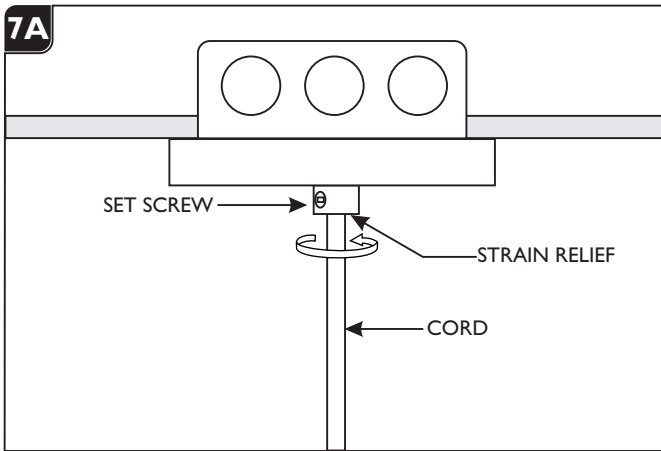

NOTE: It is recommended that one person hold the fixture while the electrician finishes the installation.

- 1 Place all wires, wire nut connections, ballast/driver, and the secondary strain relief properly inside the canopy.
- 2 Loosen the set screw on the primary strain relief.
- 3 Align the canopy center hole with the crossbar center hole.
- 4 Slide the canopy up against the ceiling and secure it in place by tightening the primary strain relief into the crossbar. **Do not turn the cord.**
- 5 Push the cord into the canopy and line up the marked point on the cord with bottom of the primary strain relief.
- 6 Tighten the plastic set screw to secure the cord.

Adjust the Suspension Cables (Optional for Multiple Suspension Cable Canopies)

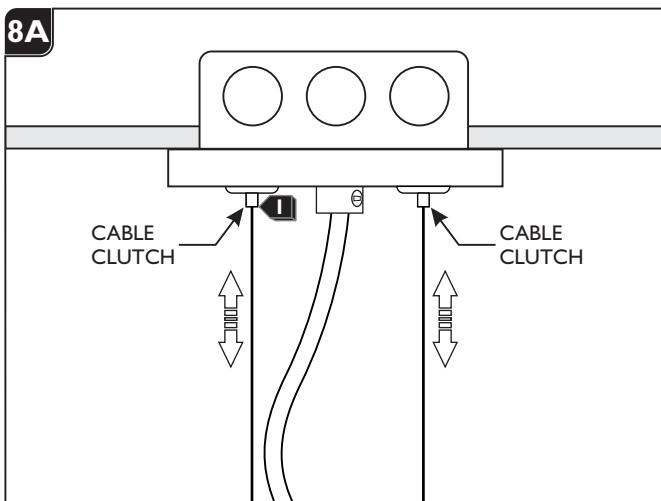

- 1 Adjust the aircraft cables until the fixture is level; feed the cable into the cable clutch to raise the fixture and push in on the cable clutch nipple to release the cable and lower the fixture.

SAVE THESE INSTRUCTIONS!

 **TECH LIGHTING**
7400 Linder Ave, Skokie, IL 60077
847.410.4400

www.techlighting.com

© 2020 Tech Lighting, L.L.C. All rights reserved.

Visual Comfort & Co.