



Bronze Relief Valves

Dome Top - Screwed or Flanged Connections

GRESSWELL G55 RELIEF VALVES

Side Outlet discharge with leak proof Dome Cover over the adjusting screw. These valves are commonly used for preventing a safe pressure being exceeded in pressurised systems.

The lift is proportional to the system overpressure.

Available with stainless steel trim, PTFE, viton and silicon soft seats.

SIZE RANGE

DN	15	20	25	32	40	50	65	80
in	1/2"	3/4"	1"	1 1/4"	1 1/2"	2"	2 1/2"	3"

PIPE CONNECTIONS

INLET: Threaded 'G' (BSP) Male to BS EN ISO 228/BS 2779

OUTLET: Threaded 'Rp' Parallel Female to BS 21/BS EN 10226/ISO 7

Alternative thread standards, e.g. 'R' x 'Rc' (BSPT) or ANSI B1.20.1 (NPT) are available upon request.

FLANGED: Most flange standards can be accommodated, e.g. BS EN 1759 (Class designated), BS EN 1092 (PN designated) or BS 10 (Table designated) - please specify.

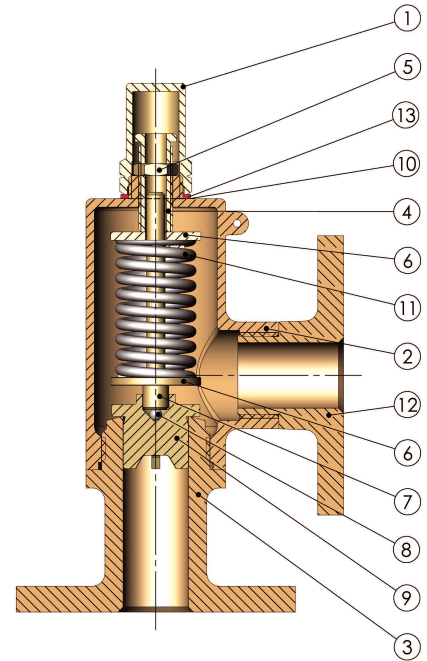

STANDARD SPECIFICATION

No.	Component	Material	No.	Component	Material
1	Dome Top	Cu Alloy BS EN 12164 CW614N	6	Spring Plate	Cu Alloy BS EN 12164 CW614N
2	Body	Cu Alloy BS EN 1982 CC491K	7	Spindle	Cu Alloy BS EN 12164 CW614N
3	Base (Metal Seat)	Cu Alloy BS EN 1982 CC491K	8	Ball	St. Steel AISI 420
3P	PTFE Seat	Virgin PTFE	9	Valve	Cu Alloy BS EN 12165 CW602N
3V	Viton Seat	Viton 85 Brown	10	Label	Metallised Polymer
3S	Silicone Seat	Silicone 50 Blue	11	Spring 15 - 50mm	St. Steel BS2056 302 S26
3FL	Flanged Inlet	Cu Alloy BS EN 1982 CC491K		Spring 65 & 80mm	Carbon Steel BS5216 ND3
4	Adjusting Screw	Cu Alloy BS EN 12164 CW614N	12	Flanged Outlet	Cu Alloy BS EN 1982 CC491K
5	Lock Nut	Cu Alloy BS EN 12164 CW614N	13	Washer	Fibre

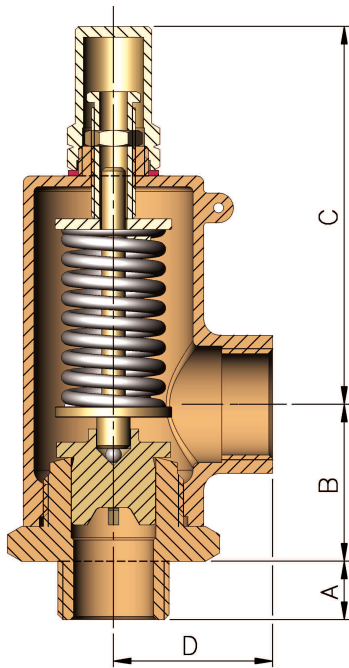

FEATURES & BENEFITS

Gresswell Valves are quality assurance approved to BS EN ISO 9001: 2008. Certificate No. 10002498.

Manufactured in accordance with BS 6759 Parts 1, 2 & 3 and compliant with BS EN ISO 4126 Part 1 with full Cat IV PED approval.

Only 3 springs are needed to cover the full pressure range.

Clear operating and maintenance instructions are supplied with each despatch.

Screwed/Flanged or a combination of both are available as standard.

See leaflet Ref: DC G55 & G90 for Discharge Capacities.

TESTING

All Gresswell Relief Valves are given a hydraulic seat tightness test before leaving the factory and the adjustment range is clearly marked.

All valves are supplied pre-set.

Flanged valves are pressure tested to ensure soundness of joints.

Special tests or witness testing can be arranged at extra cost.

DIMENSION CHART

Size	A	B	C	D	Weight (kg)
DN15	16	35	87	34	0.6
DN20	16	36	97	40	0.8
DN25	17	47	113	48	1.5
DN32	23	51	136	51	2.0
DN40	24	51	138	56	2.6
DN50	27	60	127	62	3.5
DN65	28	87	156	78	6.9
DN80	28	94	170	83	9.0

All dimensions in millimetres (mm). Flange dimensions vary according to specification (available upon request).

SEAT TYPES - SPRING/PRESSURE RANGES

Seat Housing	Valve Disc	Pressure Range	Temperature Range	Spring Ranges (bar & p.s.i.)		
				A (Low)	B (Medium)	C (High)
Bronze	Bronze	to 20.7 bar (300 p.s.i.)	-15° to +225°C	0.5 - 3.5 (7 - 50)	3.5 - 10.4 (50 - 150)	10.4 - 20.7 (150 - 300)
Bronze PTFE insert	Bronze	to 20.7 bar (300 p.s.i.)	-15° to +225°C	0.5 - 3.5 (7 - 50)	3.5 - 10.4 (50 - 150)	10.4 - 20.7 (150 - 300)
Bronze VITON seal†	Bronze	to 20.7 bar (300 p.s.i.)	-15° to +200°C	0.5 - 3.5 (7 - 50)	3.5 - 10.4 (50 - 150)	10.4 - 20.7 (150 - 300)

† SILICON seal also available on request - available set pressures will be confirmed at time of order.



GRESSWELL VALVES

Halesfield 21, Telford, Shropshire, TF7 4NX

Tel: 01952 580946 Fax: 01952 582546

email: sales@gresswellvalves.com

www.gresswellvalves.com