



Stainless Steel Relief Valves Dome Top - Screwed or Flanged Connections

GRESSWELL G36 RELIEF VALVES

Side Outlet discharge with leak proof Dome Cover over the adjusting screw. These valves are commonly used for preventing a safe pressure being exceeded in pressurised systems.

The lift is proportional to the system overpressure.

Available with PTFE, viton and silicon soft seats.

SIZE RANGE

DN	15	20	25	40	50
in	½"	¾"	1"	1½"	2"

PIPE CONNECTIONS

INLET: Threaded 'G' (BSP) Male
to BS EN ISO 228/BS 2779

OUTLET: Threaded 'Rp' Parallel Female
to BS 21/BS EN 10226/ISO 7

Alternative thread standards, e.g. 'R' x 'Rc' (BSPT) or ANSI B1.20.1 (NPT) are available upon request.

FLANGED: Most flange standards can be accommodated, e.g. BS EN 1759 (Class designated), BS EN 1092 (PN designated) or BS 10 (Table designated) - please specify.

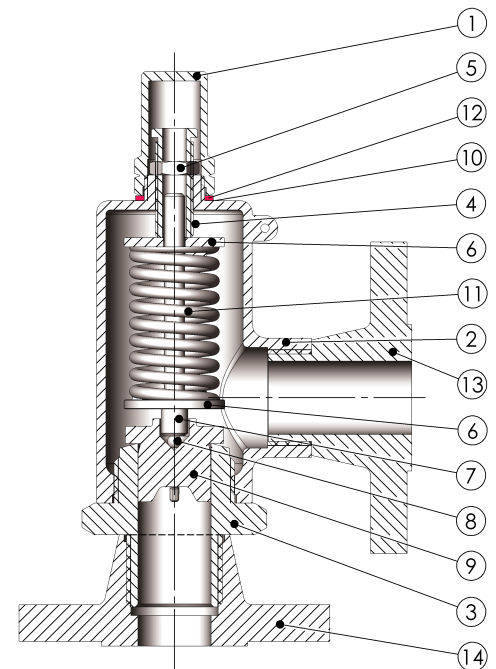

STANDARD SPECIFICATION

No.	Component	Material	No.	Component	Material
1	Dome Top	St. Steel AISI 316 (DIN 1.4401)	6	Spring Plate	St. Steel AISI 316 (DIN 1.4401)
2	Body	St. Steel ASTM A351/A351M CF8M	7	Spindle	St. Steel AISI 316 (DIN 1.4401)
3	Base	St. Steel ASTM A351/A351M CF8M	8	Ball	St. Steel AISI 420
3P	PTFE Seat	Virgin PTFE	9	Valve	St. Steel ASTM A351/A351M CF8M
3V	Viton Seat	Viton 85 Brown	10	Label	Metallised Polymer
3S	Silicone Seat	Silicone 50 Blue	11	Spring	St. Steel BS2056 302 S26
4	Adjusting Screw	St. Steel AISI 316 (DIN 1.4401)	12	Washer	PTFE
5	Lock Nut	St. Steel AISI 316 (DIN 1.4401)	13/14	Flanges (optional)	St. Steel AISI 316L (DIN 1.4404)

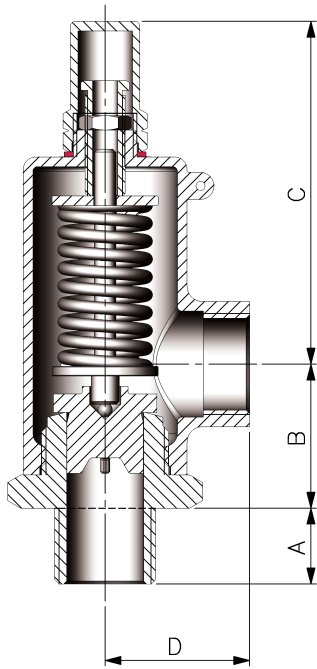

FEATURES & BENEFITS

Gresswell Valves are quality assurance approved to BS EN ISO 9001: 2008. Certificate No. 10002498.

Manufactured in accordance with BS 6759 Parts 1, 2 & 3 and compliant with BS EN ISO 4126 Part 1 with full Cat IV PED approval.

Only 3 springs are needed to cover the full pressure range.

Clear operating and maintenance instructions are supplied with each despatch.

Screwed/Flanged or a combination of both are available as standard.

See leaflet Ref: DC G36 for Discharge Capacities.

TESTING

All Gresswell Relief Valves are given a hydraulic seat tightness test before leaving the factory and the adjustment range is clearly marked.

All valves are supplied pre-set.

Flanged valves are pressure tested to ensure soundness of joints.

Special tests or witness testing can be arranged at extra cost.

DIMENSION CHART

Size	A	B	C	D	Weight (kg)
DN15	17	35	87	33	0.6
DN20	14	36	97	40	0.8
DN25	25	47	113	48	1.5
DN40	23	53	134	56	2.6
DN50	27	61	126	62	3.5

All dimensions in millimetres (mm). Flange dimensions vary according to specification (available upon request). Please note that DN32, DN65 & DN80 valves are not available in stainless steel.

SEAT TYPES - SPRING/PRESSURE RANGES

Seat Housing	Valve Disc	Pressure Range	Temperature Range	Spring Ranges (bar & p.s.i.)		
				A (Low)	B (Medium)	C (High)
316 St. Steel	316 St. Steel	to 20.7 bar (300 p.s.i.)	-60° to +350°C	0.5 - 3.5 (7 - 50)	3.5 - 10.4 (50 - 150)	10.4 - 20.7 (150 - 300)
316 St. Steel PTFE insert	316 St. Steel	to 20.7 bar (300 p.s.i.)	-40° to +225°C	0.5 - 3.5 (7 - 50)	3.5 - 10.4 (50 - 150)	10.4 - 20.7 (150 - 300)
316 St. Steel VITON seal	316 St. Steel	to 20.7 bar (300 p.s.i.)	-15° to +200°C	0.5 - 3.5 (7 - 50)	3.5 - 10.4 (50 - 150)	10.4 - 20.7 (150 - 300)

† SILICON seal also available on request - available set pressures will be confirmed at time of order.



GRESSWELL VALVES

Halesfield 21, Telford, Shropshire, TF7 4NX
 Tel: 01952 580946 Fax: 01952 582546
 email: sales@gresswellvalves.com
 www.gresswellvalves.com