

User Manual of Intelligent Robotic Vacuum Cleaner

V41P

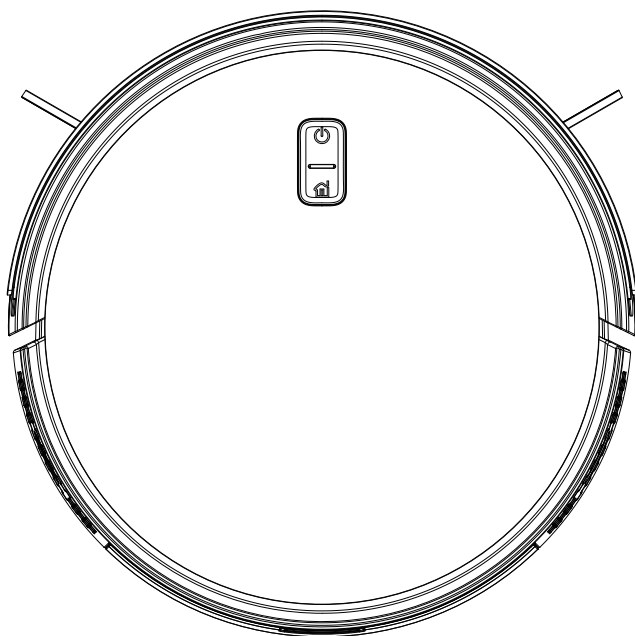

Customized for you for more convenient and quieter cleaning without leaving any dead corners

Table of Contents

Safety Instructions	1~3
Instructions for use	1
Safety warnings	1
Safety precautions	2
Child safety	2
About the batteries	3
Scope of use	3
Disclaimers	3
Precautions for Use	4
Use restrictions	4
Battery and charging	4
Product List	5
Product Appearance	6~7
Main machine	6
Dust box and water tank module	7
Mopping module	7
Charging dock	7
Installation Instructions	8~9
Remote Control Instructions	10
Product appearance	10
Button operation instructions	10
Main Machine Instructions	11
Cleaning/pause	11
Automatic cleaning	11
Timed cleaning	11
Charging	11
Cleaning of designated rooms with magnetic strips	11
Reset Wi-Fi	11
Cleaning mode	11
Daily Maintenance	12~15
Dust box and filter	12
Water tank and mopping module	13
Rolling brush/Side brush	14
Sensor	14
Universal wheel	15
Charging pole piece	15
Battery	15
Basic Parameters	16
Common Faults	16
Troubleshooting	17
Warranty Card	18

Safety Instructions

Instructions for use

Please pay attention to the following basic safety precautions before using the product:

- * Read the user manual carefully and follow the instructions in the user manual when using the product.
- * Keep the user manual well for future reference.
- * If you need to transfer the product to a third party, please attach the user manual along with the product.
- * Any operation not in conformity to the instructions in the user manual may result in serious personal injury or damage to the product itself.

Safety warnings

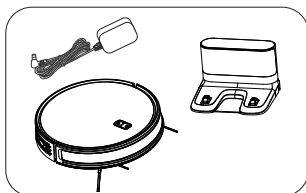

⚠ This product can only use the adapter, batteries and charging dock that are provided with this product. Failure to do so may result in damage to the product, electrical shock, or fire caused by high voltage.

⚠ Do not use this product if the host machine and accessories of this product are found to be damaged. Contact our after-sales service department. Except for the service technicians designated or authorized by our company, no one may disassemble, repair or modify this product.

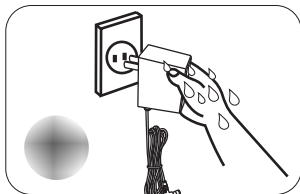

⚠ Unplug the product before maintenance.

⚠ Do not touch the power plug or the product when your hands are wet, as this may result in electrical shock.

⚠ If the power cord is damaged, it must be replaced by the manufacturer, its service department or a similar professional to avoid danger.

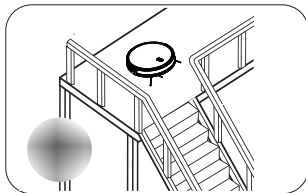

⚠ To prevent the product from falling accidentally, do not use this product in a suspended place without a protective fence, which may result in personal injury.

⚠ In most cases, the anti-drop sensor can prevent the robotic vacuum cleaner from rolling down the stairs and falling suddenly. If the sensor is dirty or the robotic vacuum cleaner is used on a carpeted, reflective or dark-colored floor, the sensitivity of the sensor will decrease. It is recommended to set up a physical barrier in the area where the robotic vacuum cleaner may fall.

⚠ The user shall not replace the batteries privately.

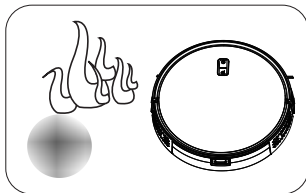

⚠ Prevent clothing or any part of your body (hair, fingers, etc.) from getting caught in the brush or wheel of the robotic vacuum cleaner. Failure to do so may result in personal injury.

⚠ Do not place the product near fire or flammable/explosive/corrosive materials.

⚠ If the user manual is lost, please contact your local dealer to obtain the electronic version of the manual.

Safety precautions

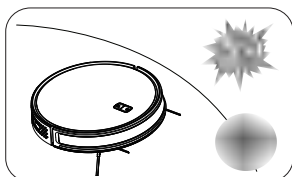

- The product can only be used indoors.

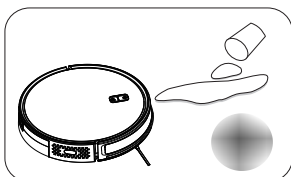

- Prevent the suction of water, oil or other liquids, which may damage the vacuum cleaner.

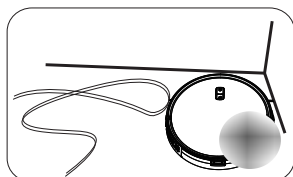

- Arrange scattered wires on the floor before use for fear of affecting the normal operation of the vacuum cleaner.



- Remove fragile objects before use.

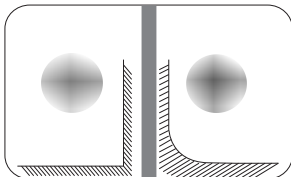

- The charging dock shall be placed against the wall and on a flat floor for fear of affecting product functionality.

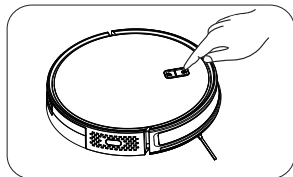

- Please wait for 15 seconds after power on. The robotic cleaner is checking.

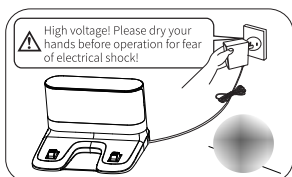

- Unplug the charging dock if it remains unused for a long time.

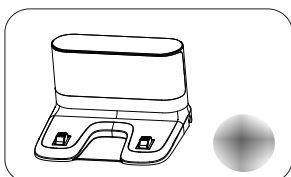

- When the product is working, removal of the charging dock will affect the normal recharging of the machine.

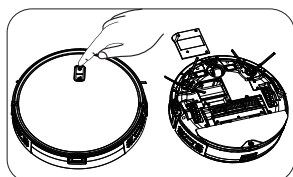

- Please turn off the power switch when the robot cleaner is not in use, so as to avoid damage to the battery. It is required to use the manufacturer's original battery, otherwise damage or accident may occur.

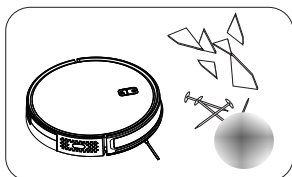

- Do not use the product to suck in sharp objects (e.g. shattered glass and nails) for fear of damage to the product.

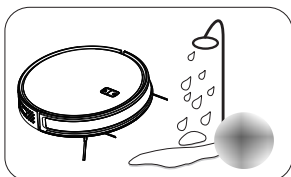

- Do not use the product in a wet, flammable, explosive or corrosive environment.

Child safety



* Children under the age of 8 are not allowed to use this product. Persons with physical, sensory or intellectual disabilities or lack of relevant experience/knowledge cannot use the machine unless under supervision, operating instructions or awareness of the danger. Children are not allowed to play with the machine or clean/repair the machine unless under supervision.

* Children are not allowed to play with the product's packaging bag for fear of suffocation.

About the batteries



1. Only the batteries provided by the manufacturer are applicable to the product.
2. Be sure to turn off the power switch before taking out the battery.
3. The batteries shall be removed when the product is discarded.
4. If you need to replace the battery of the host machine, please contact our after-sales service department.
Use of wrong batteries may cause a safety accident.
5. In case of battery leakage, protect your skin and clothing against the battery fluid. Wipe off the fluid with a dry cloth immediately and send the battery to a recycling station or an authorized service center. Do not throw it away.
6. Please properly dispose of the old batteries of the product. The batteries contain hazardous substances harmful to the environment. Please follow the local environmental regulations and send them to the designated recycling site.



Scope of use

* The product is suitable for the following floors:



Wooden floor

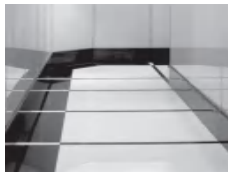

Ceramic tile

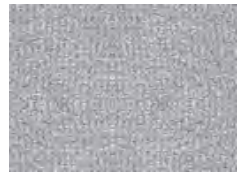

Short-staple carpet

Disclaimers

Under any of the following circumstances, the product will be excluded from the scope of free warranty, but paid repair can be provided:

- A. Damage due to the user's failure to operate the product in strict accordance with our user manual or due to improper storage;
- B. The machine or parts have exceeded the free warranty period;
- C. Damage due to disassembly by those other than the maintenance personnel of our company or authorized by our company;
- D. A valid purchase voucher number cannot be provided;
- E. The product model on the warranty card does not match that of the product to be repaired or is altered;
- F. Damage caused by irresistible factors such as natural disasters;
- G. Product failure or damage caused by unexpected factors or man-made causes (including operational errors, liquid ingress, improper plugging/unplugging, scratching, handling, bumping, input of inappropriate voltage, etc.)

Note : Our company provides a warranty for the product in accordance with the "National New Regulations on Warranty". For details, please check the warranty card provided with the product.

Precautions for Use

Use restrictions

- The product is only used for floor cleaning in the home environment. Do not use it outdoors (such as open balconies), in places other than the floor (such as sofas), or in commercial or industrial environments.
- Do not use it in a suspended environment (such as duplex floors, open balconies, top of furniture) without protective fences.
- Do not use it in an environment where the temperature is higher than 40°C or lower than 0°C, or there are any liquids and viscous objects on the floor.
- Please arrange the cables on the floor in your home before use, so as to prevent the main machine from dragging the cables during operation.
- Please put away the fragile objects and sundries on the floor (such as vases and plastic bags), so as to prevent blocking or slight collision of the main machine during operation, which may cause damage to valuables in the home.
- Do not allow people (including children) with physical, mental or sensory impairments to use or operate the product.
- Do not allow children to play with the robotic cleaner as a toy. Please supervise children and pets to stay away as much as possible when the main machine is working.
- Keep the rolling brush out of reach of children.
- Do not place any objects (including children and pets) on the stationary or moving main machine.
- When the main machine is working, please do not place any part of your body, pet hair, fingers, etc. close to the suction port of the machine put.
- Do not use it to clean burning objects (such as unextinguished cigarette butts).
- Do not use it to clean long-staple carpets (some dark-colored carpets may not be cleaned normally).
- Do not allow the main machine to pick up hard or sharp objects (such as decoration waste, glass and nails).
- Please clean or maintain the main machine and charging dock when the machine is turned off or the power is off.
- Do not wipe any part of the product with a damp cloth or any liquid.
- Please use the product in accordance with the instructions of the user manual. The user shall be responsible for any loss and injury caused by improper use.

Battery and charging

- Do not use any third-party batteries, chargers or charging docks.
- Do not disassemble, repair or modify the battery or charging stock without permission.
- Do not place the charging stock near a heat source (such as a radiator).
- Do not wipe or clean the battery connector with a damp cloth or wet hands.
- Do not throw away waste batteries at will, which shall be disposed of by a professional recycling agency.
- **If** the power cord is damaged or broken, please stop using it immediately and purchase or replace it through official channels.
- **If** you need to transport the product, please make sure that the main machine is turned off, and it is advisable to use the original packaging box.
- **If** the product is not in use for a long time, please turn off the main machine after fully charging it and store it in a cool and dry place, and charge it at least once every three months to avoid over-discharge of the battery.

Product List

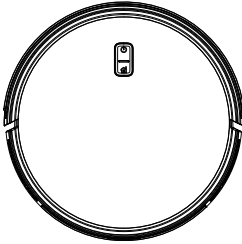

Main machine

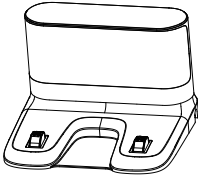

Charging dock

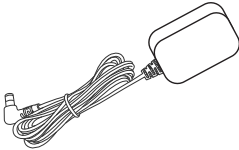

Power adapter

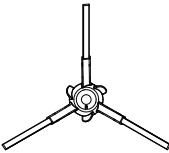

Right side brush x2
(One of them as the spare part)

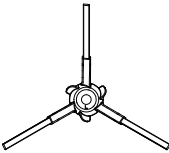

Left side brush x2
(One of them as the spare part)

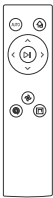

Remote control

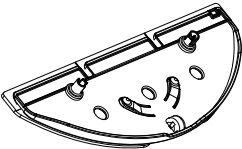

Mopping module
(Already installed on the main machine)



Cleaning brush

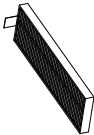

Spare filter

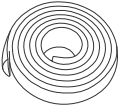

Virtual wall magnetic strip



User manual and other documents

Product Appearance

Main machine

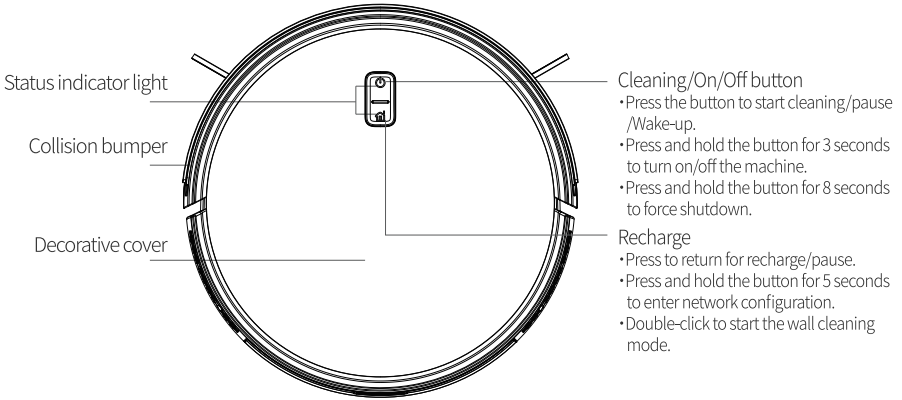

Notes:

- During cleaning, recharge or partial cleaning, press any button to pause the current task.
- Press and hold the recharge button and the collision buffer at the same time for 10s until the power indicator light goes out to enter the CEC test mode.

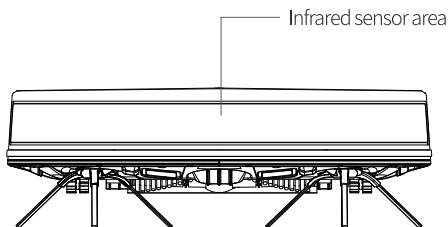
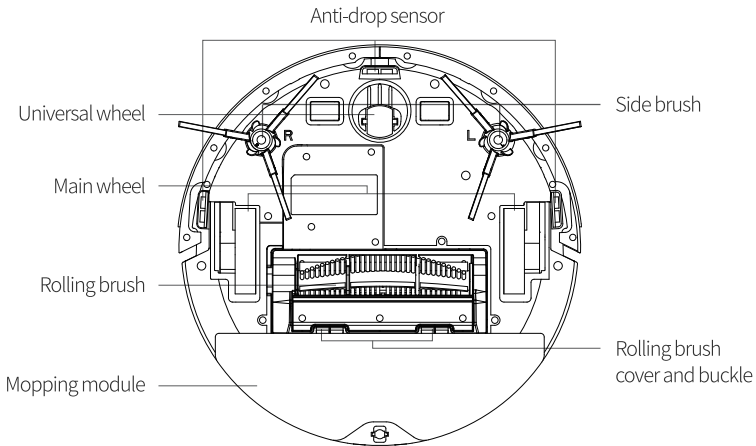

Dust box and water tank module

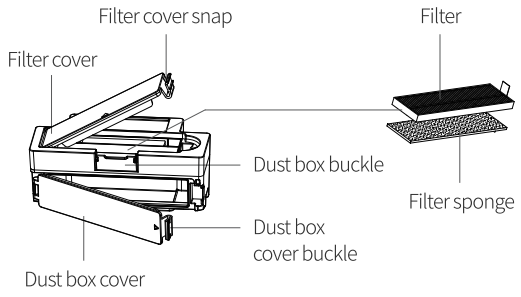
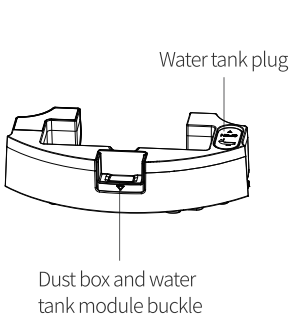
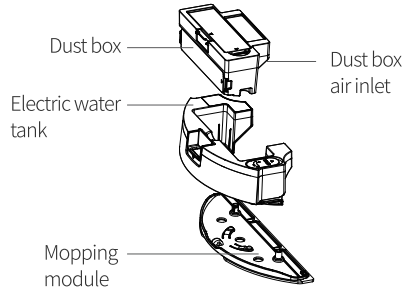
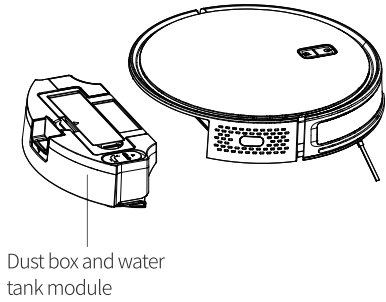

Mopping module

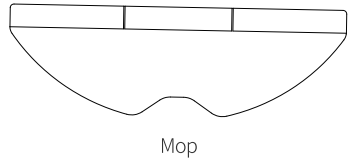
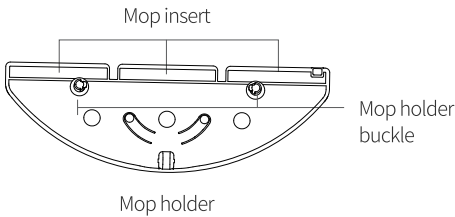

Charging dock

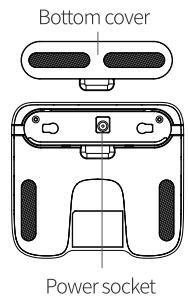
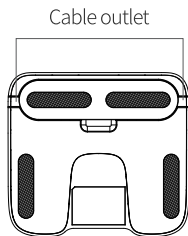
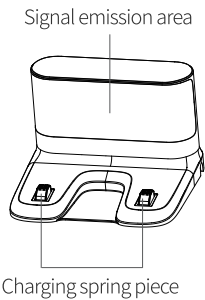

Installation Instructions

1) Connect the power cord, put the excess wire into the wire slot, and remove the lens protective film before use.

Notes:

- The power cord hanging on the floor may be dragged by the main machine, causing power disconnection of the charging dock.
- When the machine is charged, the indicator light of the machine flashes intermittently.

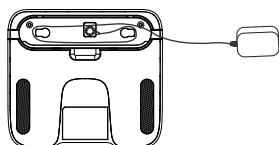

2) Place the charging dock on the level floor and connect it to the power source.

Note:

- Please make sure that there are no obstacles within at least 2 meters in front and 1 meter on the left and right.

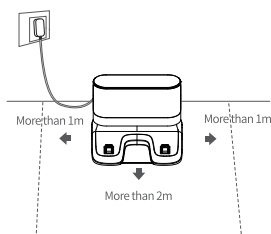

3) To facilitate the cleaning and better recharging of the main machine, please do not move the charging dock randomly and frequently. If the position of the charging dock is changed, the main machine may lose the position memory of the charging dock. When recharging again, it will relocate and search for the charging dock.

Note:

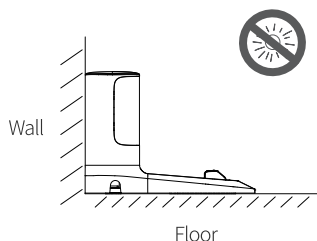

- Avoid direct sunlight.
- For better recharging, do not put the charging dock on the carpet.
- Do not install the machine on or near the wooden floor for fear of damage of the floor by the damp mop.
- When the machine completes the cleaning task and returns to the charging dock for recharge, please take out the mopping module promptly and pour out the water in the water tank.
- If the machine stays somewhere for a long time due to failure when mopping the floor, please solve this problem promptly for fear of damage of the floor by the damp mop.

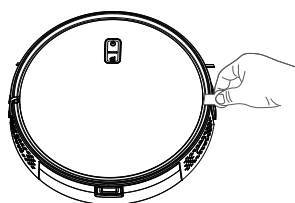

4) Before use, please remove the protective strip and protective film on the front bumper of the device to ensure the normal use of the device.



5) Turn on and charge

Press and hold the button  to turn on the main machine, and the indicator light flashes slowly. Place the main machine within one meter directly in front of the charging dock, click on the button , and the main machine will automatically search for the charging dock and proceed to charge.

Note:

- The machine cannot be turned on if the battery level is low. Please place the main machine on the charging dock, and it will automatically turn on. The main machine can be turned on, and work normally when its battery level is $\geq 12\%$.

Charging dock

Main machine

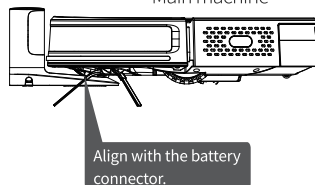

6) Install the mopping module

a. Install the mop

Wet the mop and wring it out until it does not drip. Insert the mop as shown in the figure, and stick it firmly.

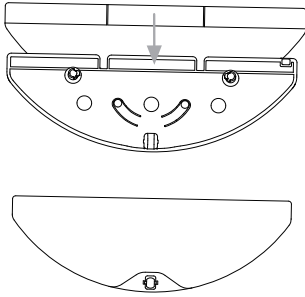

b. Place the mopping module

Take out the dust box and water tank module, make sure that the water tank cover is closed tightly and there is no water leakage, align the mop holder buckle with the corresponding hole of the dust box and water tank module, and install the mopping module.

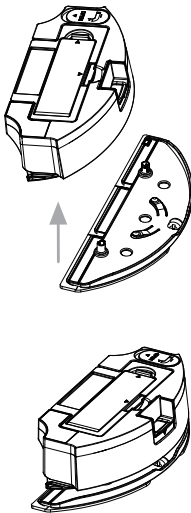

Tips:

- Never overturn the machine when installing the mopping module.
- If there is trash in the dust box, please empty it or take out the separate dust box before installing the mopping module.

c. Fill the water tank with water

Open the water tank cover, fill it with tap water and put back the water tank cover.

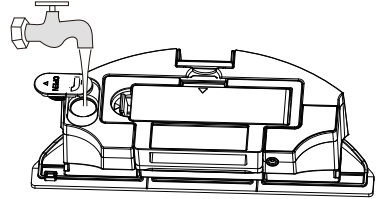

Tips:

- This machine does not support the use of floor cleaners or disinfectants. Do not use any cleaner other than those specified, as it might damage the robotic vacuum cleaner.
- For the sake of a long service life, it is advisable to use softer tap water or pure water.

d. Install the module

Put the installed dust box and water tank module (with the mopping module) back into the machine.

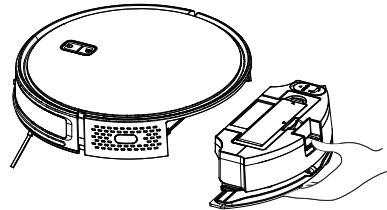

Tips:

- The mopping mode is only suitable for clean floors without tough stains.
- In order to achieve a better effect, it is advisable to use the robotic vacuum cleaner to clean the floor thrice before installing the mopping module.

Remote Control Instructions

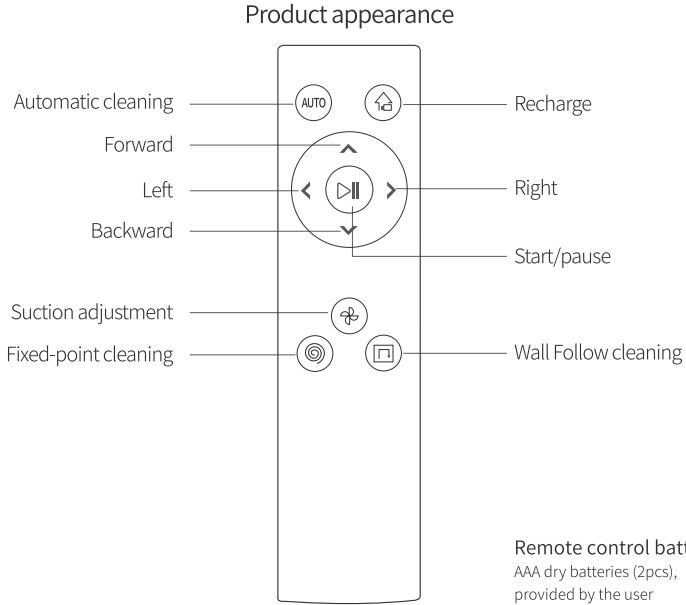

Button operation instructions

Button	Operation	Function Description
Cleaning startup/ pause button	Press it (when the machine is paused).	Start cleaning (continue cleaning if there is a cleaning task, and start the automatic cleaning mode if there is no cleaning task).
	Press it (when the machine is operating).	Pause/stop: including cleaning pause and recharging stop.
Forward button	Press it to work. Release it to stop.	Start remote cleaning according to the received signal and move forward.
Left button		Start remote cleaning according to the received signal and rotate to the left on the spot.
Right button		Start remote cleaning according to the received signal, and rotate to the right on the spot.
Backward button		Start remote cleaning according to the received signal and move backward.
Recharge button	Press it.	Start/pause recharging.
Suction adjustment	Press it.	Press it to cycle through the suction levels.
Fixed-point cleaning	Press it.	Fixed-point cleaning: It starts spiral cleaning with the current position of the robotic cleaner as the starting point, and returns to the starting point to end the cleaning when it hits an obstacle or the diameter reaches 1 meter.
Wall Follow cleaning	Press it.	The main machine moves straight forward, and when the wall is identified, it starts to clean along the wall. After performing cleaning twice, it automatically returns for recharge.

Tips :

- When the machine is sleeping, you need to press its button to wake it up before using it.
- To ensure the cleaning effect, when the machine is in the charging dock, the fixed-point cleaning can not be activated.
- In order to avoid misoperation, you can not use the remote control to wake up the main machine in the sleep mode, and you need to press the sweeping button on the main machine to wake it up.

Main Machine Instructions

Cleaning/pause

Method 1: After turning on the machine, press and hold the button  on the main machine to start cleaning (press any button to pause during cleaning).

Method 2: Click on the cleaning button in the APP to start cleaning (press the pause button to pause the current task).

Note :

- The robotic cleaner cannot be used to clean liquids.
- If the battery level is lower than 12%, the cleaning task cannot be performed. Please charge the battery before starting the cleaning.
- Please arrange all kinds of wires on the floor (including the power cord of the charging dock) before cleaning, so as to prevent the main machine from dragging wires or objects during cleaning, which may cause power disconnection or damage to objects or wires.

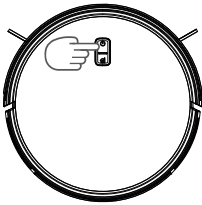

Method 1

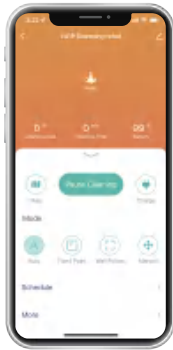

Method 2

Automatic cleaning

The main machine starts to clean in a bow-shaped path. After the entire room is cleaned, it enters the Wall Follow cleaning mode. After performing Wall Follow cleaning twice, it automatically returns for recharge.

Timed cleaning

You can use the mobile App to preset the cleaning time, and the main machine will automatically start cleaning at the specified time, and automatically return to the charging dock to charge after the cleaning is over.

Charging

Automatic mode: After the cleaning is over, the device will automatically return to the charge dock for charging.

Manual mode: In the pause state, press the button  to start recharge, or start recharge in the App. The indicator light flashes intermittently when the device is charged.

Note :

- If the device fails to find the charge dock, please manually put the main machine back onto the charging dock for charging.

Cleaning of designated rooms with magnetic strips

When you want to specify a room for separate cleaning, the robotic cleaner will not go beyond the magnetic strip and will clean the current room separately if a magnetic strip is placed at the door of the designated cleaning room.

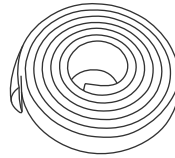

Reset Wi-Fi

When the mobile phone cannot connect to the device due to change of configuration or password of the router or other reasons, please press and hold the button  for 5 seconds until there is a voice prompt "Wi-Fi has been reset", and the Wi-Fi indicator light turns to blue and flashes fast, indicating that the reset is successful. (Figure 1)

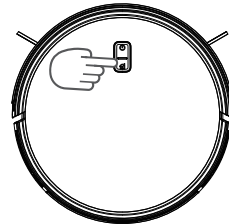

(Figure 1)

Cleaning mode

Use the mobile App to choose Automatic, Wall Follow or Fixed-point cleaning.

Daily Maintenance

Please turn off the machine and unplug the adapter before cleaning and maintaining the machine.

Dust box and filter

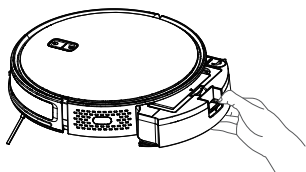

Step 1

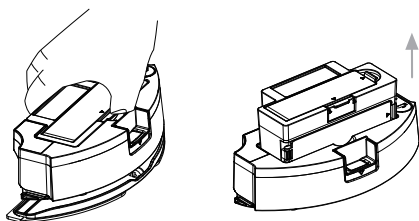

Step 2

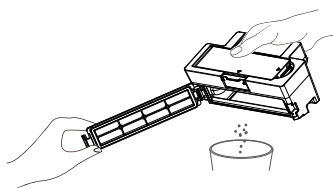

Step 3

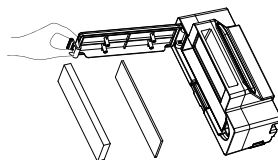

Step 4

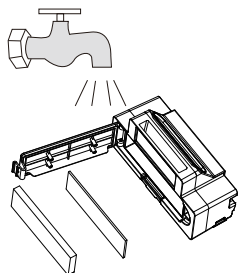

Step 5

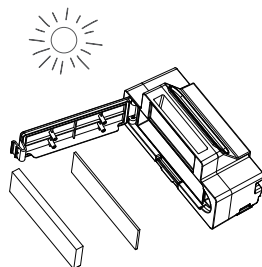

Step 6

Step 1: Press the button to take out the dust box and water tank module.

Step 2: Press the buckle of the dust box and take out the dust box.

Step 3: To avoid spilling trash, keep the dust box opening up. Hold the dust box with your right hand, open the buckle of the dust box cover with your left hand, and pour out the trash. To avoid clogging of the filter, please tap the dust box gently when pouring out the trash. (It is advisable to empty the dust box after each cleaning or at least once a week.)

Step 4: After a long period of use, remove the filter assembly (It is advisable to replace the filter assembly every 6-12 months to ensure good cleaning effect of the device).

Step 5: Rinse the dust box and filter (not too frequently but advisably monthly).

Step 6: After rinsing, shake off water droplets vigorously. Please be sure to wait until the dust box and filter are completely air-dried before using it to ensure its service life.

Note:

- Please rinse with clean water. Do not add any detergent. Do not clean the filter with a brush or fingers.
- Do not put an incomplete dust box into the device to avoid accidentally triggering the cleaning operation and causing the air duct of the machine to be blocked and damaged.

Water tank and mopping module

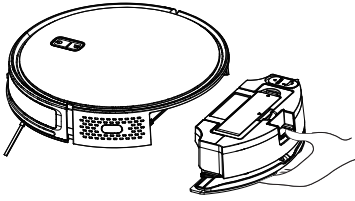

Step 1

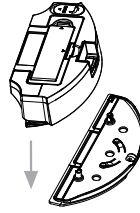

Step 2

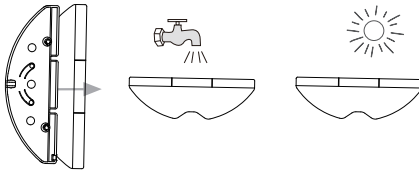

Step 3

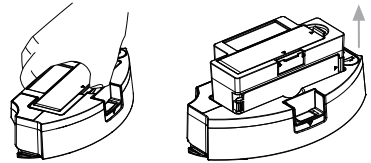

Step 4

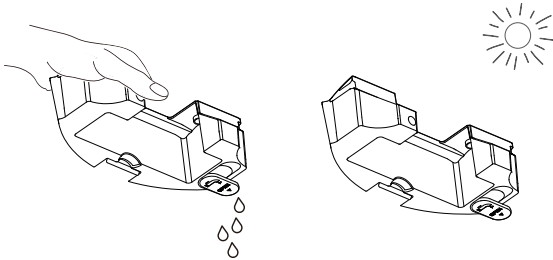

Step 5

Step 1: Press the button to take out the dust box and water tank module (with the mopping module).

Step 2: Remove the mopping module from the dust box and water tank module.

Step 3: Take the mop out of the mop holder, clean the mop and dry it before use.

Step 4: Press the buckle of the dust box, take out the dust box, and separate the dust box from the water tank.

Step 5: Take out the water tank, open the plug of the water tank, pour out the remaining water, and then shake off the water drops forcefully. If the water tank is to be left aside for a long time, please air-dry it completely to ensure its long service life.

Note:

- It is advisable to replace the mop regularly depending on the conditions of the mop, so as to ensure a good cleaning effect of the machine.
- Remove the mopping module promptly after each use, and clean the mop and water tank to prevent mold or unpleasant odors.

Rolling brush (to be cleaned every week)

- 1) Invert the robotic vacuum cleaner, press the buckle on the rolling brush cover to open the roller brush cover, and take out the rolling brush.
- 2) Use the blade on the cleaning brush to cut off the hair entangled on the rolling brush.
- 3) The bearing on the left side of the rolling brush can be removed to facilitate the removal of the hair entangled in the gap between the two ends.

Note :

- It is advisable to replace the rolling brush every 6-12 months to ensure a good cleaning effect of the machine.

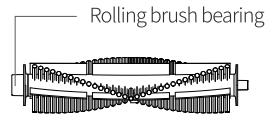
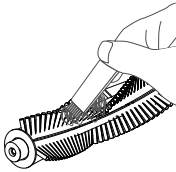

Side brush (to be cleaned every month)

- 1) Invert the robotic vacuum cleaner, remove the side brush, clean away the entangled hair and dirt inside, and then reinstall it.
- 2) The hair entangled on the side brush bristles can also be effectively removed by the blade on the cleaning brush.

Note:

- It is advisable to replace the main brush every 3-6 months to ensure a good cleaning effect of the device.

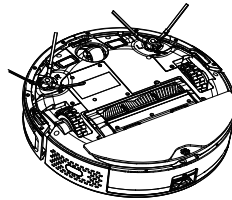
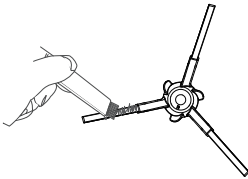

Sensor

Wipe and clean all the sensors of the main machine with a soft dry cloth, including:

- 1) Wall sensors on the left and right sides of the main machine
- 2) 3 anti-drop sensors at the bottom of the main machine
- 3) Infrared sensors on the left and right sides and front side of the main machine

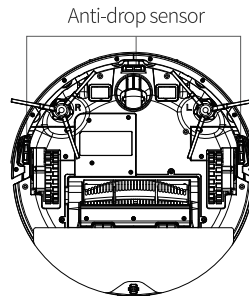
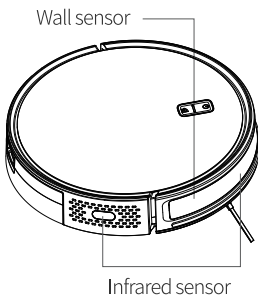

Universal wheel (to be cleaned every month)

Turn over the device and pull out the universal wheel, clean the hair and dirt on the wheel and axle, and reinstall and press it tightly.

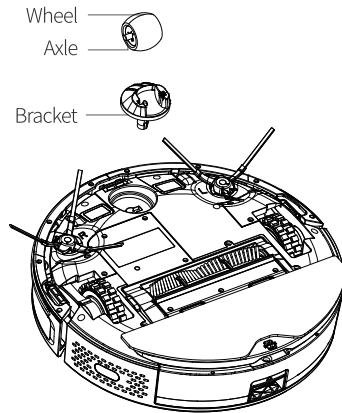

Charging pole piece

The positions of the battery electrode and the battery connector are shown in the figure. Please use a dry cloth to clean them. (Turn off the power when cleaning them. It is advisable to clean them monthly.)

Charging pole piece

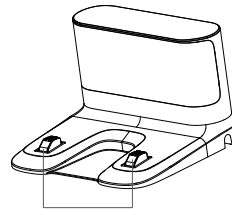
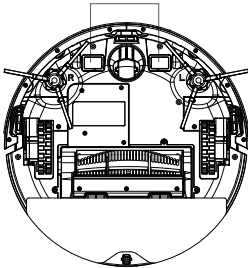





Charging spring piece

Battery

- The main machine has a built-in high-performance rechargeable lithium battery pack. In order to maintain battery performance, please keep the main machine in a charged state after daily use.
- If the machine is to be left aside for a long time, please turn it off for storage. In order to avoid damage to the battery due to over-discharge, it is advisable to charge it at least every three months.

Basic Parameters

Main machine		Charging dock	
Dimensions	328*328*81mm	Dimensions	145*131*94mm
Rated voltage	14.4V 	Rated power	12W
Input power	19V  0.6A	Output voltage	19V 
Battery	Lithium battery	Output current	0.6A 
Charging time	≤ 5h		
Noise	≤ 65dB (standard level)		

Common Faults

Fault	Solution
Startup failure	Place the device on the charging dock and align it with the battery connector, and the device will automatically turn on.
Charging failure	<ol style="list-style-type: none"> 1) Please remove the device, and make sure that both ends of the power adapter of the charging dock are plugged in. 2) Please wipe the battery connector and the battery electrode.
Recharge failure	<ol style="list-style-type: none"> 1) Please remove the obstacles near the charging dock and place the charging dock in an open area. 2) Please place the main machine next to the charging dock for recharge.
Abnormal operation	Shut down and restart.
Abnormal noise during cleaning	Clean the rolling brush, the side brush or the wheels after shutdown.
Decreased cleaning ability or dirt leakage	<ol style="list-style-type: none"> 1) Please clean the dust box. 2) Please clean or replace the filter. 3) Please clean the rolling brush.
Failure to connect to Wi-Fi	<ol style="list-style-type: none"> 1) Please make sure that the main machine is the area well covered by the Wi-Fi signal. 2) Please reset Wi-Fi, download the latest mobile client, and connect again. 3) Please check whether the password is wrong or contains special characters. 4) Please check whether it is connected to a 5G network, as the robotic vacuum cleaner only supports 2.4G networks.
Timed cleaning doesn't work	<ol style="list-style-type: none"> 1) Please check whether the battery level is ≥12% as timed cleaning will be started only when the battery level is ≥12%. 2) Please check whether the timed cleaning cycle is set accurately.

Troubleshooting

Voice Prompt and Indicator Light Prompt	Possible Cause
Error 0: You can hear the voice prompt "Please put back the dust box, and start again". And the start button and the recharge button flash slowly in red at the same time.	Cleaning is triggered when the dust box is taken out.
Error 1: You can hear the voice prompt "The cliff does not work well. Please wipe and move it to a new position to start". And the start button and the recharge button are normally on in red at the same time.	The device is picked up; or the device is suspended in the air.
Error 2: You can hear the voice prompt "The cliff sensor does not work well. Please wipe and move it to a new position, and start again". And the start button and the recharge button are normally on in red at the same time.	The anti-fall sensor is blocked or the device is placed in a high place.
Error 3: You can hear the voice prompt "The collision buffer is stuck. Please check". And the start button and the recharge button are normally on in red at the same time.	Its edge or collision sensor is stuck.
Error 4: You can hear the voice prompt "The charging does not work well. Please wipe the charging contact area". And the start button and the recharge button are normally on in red at the same time.	Excessive wear of the charging pole pieces of the robotic vacuum cleaner causes poor contact.
Error 5: You can hear the voice prompt "The fan does not work well. Please check and clean the filter". And the start button and the recharge button are normally on in red at the same time.	The fan of the robotic vacuum cleaner is blocked.
Error 6: You can hear the voice prompt "The battery level is low. Please put it back in the charging dock for recharge". And the start button and the recharge button are normally on in red at the same time.	Cleaning is triggered when the battery is extremely low and the main machine is not on the charging dock (the battery level is less than 5%).
Error 7: You can hear the voice prompt "Please put the machine on a level floor, and start again". And the start button and the recharge button are normally on in red at the same time.	The machine is tilted.
Error 8: You can hear the voice prompt "The wheels are stuck. Please check whether there are foreign objects stuck in the wheels, or move the machine to a nearby position and start again". And the start button and the recharge button flash slowly in red at the same time.	The wheels are stuck or entangled.
Error 9: You can hear the voice prompt "The rolling brush is stuck. Please remove the rolling brush and clean it". And the start button and the recharge button flash slowly in red at the same time.	The rolling brush is entangled or stuck.
Error 10: You can hear the voice prompt "The side brush is stuck. Please check". And the start button and the recharge button flash slowly in red at the same time.	The side brush is entangled or stuck.
Error 11: You can hear the voice prompt "The battery temperature is abnormal. Please do not use the battery until it returns to the normal temperature". And the start button and the recharge button flash slowly in red at the same time.	Abnormal battery.
Error 12: You can hear the voice prompt "The machine is trapped. Please clear away the surrounding obstacles". And the start button and the recharge button flash slowly in red at the same time.	Excessive obstacles around the robotic vacuum cleaner

- When a fault occurs during the operation of the main machine, the ring indicator flashes in red quickly and a voice prompt is given. Please refer to the above table to solve the fault.



Warranty Card



SYSPERL™

● WARRANTY CERTIFICATE
● ● ● ● ● ● ● ●
○ ○ ○ ○ ○ ○ ○ ● ● ●

ACTIVATE WARRANTY



SCAN QR CODE TO ACTIVATE WITHIN
14 DAYS, OR ACTIVATE BY VISITING
WWW.SYSPERLSHOP.COM

WARRANTY CARD

SHOP: AMAZON ALIEXPRESS EBAY

ORDER NUMBER: _____

PRODUCT MODEL
NUMBER/NAME: _____

DATE OF PURCHASE: _____

NAME: _____

ADDRESS: _____

E-MAIL: _____

PHONE: _____

SIGNATURE: _____

DATE: _____

Must return within 30 days of purchase
with copy of dated register receipt.

 Please make a copy of this for yourself, and mail to :
support.US@SysperlShop.com