

User Manual of Intelligent Robotic Vacuum Cleaner

V40P



Customized for you for more convenient and quieter cleaning without leaving any dead corners

Table of Contents

Safety Instructions	1~3
Instructions for use	1
Safety warnings	1
Safety precautions	2
Child safety	3
About the batteries	3
Scope of use	3
Disclaimers	3
Product Appearance	4~7
Main machine	4~5
Dust box	6
Charging dock	7
Product List	8
Installation Instructions	9~10
Remote Control Instructions	11
Product appearance	11
Remote control battery instructions	11
Button operation instructions	11
Main Machine Instructions	12~13
Cleaning/pause	12
Automatic cleaning	12

Charging	12
Cleaning of designated rooms with magnetic strips (optional)	13
Timed cleaning	13
Reset Wi-Fi	13
Cleaning mode	13
Daily Maintenance	14~17
Dust box and filter	14
Main brush/side brush	15
Sensor/universal wheel	16
Charging pole piece	17
Battery	17
Basic Parameters	18
Common Faults	19
Precautions for Use	20~21
Use restrictions	20
Battery and charging	21
Troubleshooting	22
Statement of Hazardous Substance Content	23
Warranty Card	24

Safety Instructions

Instructions for use

Please pay attention to the following basic safety precautions before using the product:

- * Read the user manual carefully and follow the instructions in the user manual when using the product.
- * Keep the user manual well for future reference.
- * If you need to transfer the product to a third party, please attach the user manual along with the product.
- * Any operation not in conformity to the instructions in the user manual may result in serious personal injury or damage to the product itself.

Safety warnings

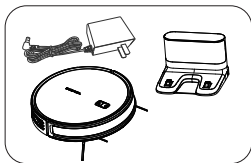

⚠ This product can only use the adapter, batteries and charging dock that are provided with this product. Failure to do so may result in damage to the product, electrical shock, or fire caused by high voltage.

⚠ Do not use this product if the host machine and accessories of this product are found to be damaged. Contact our after-sales service department. Except for the service technicians designated or authorized by our company, no one may disassemble, repair or modify this product.

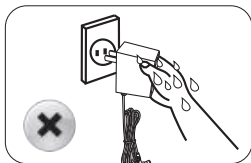

⚠ Unplug the product before maintenance.

⚠ Do not touch the power plug or the product when your hands are wet, as this may result in electrical shock.

⚠ If the power cord is damaged, it must be replaced by the manufacturer, its service department or a similar professional to avoid danger.

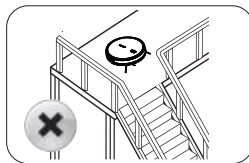

⚠ To prevent the product from falling accidentally, do not use this product in a suspended place without a protective fence, which may result in personal injury.

⚠ The user shall not replace the batteries privately.

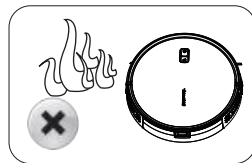

⚠ Prevent clothing or any part of your body (hair, fingers, etc.) from getting caught in the brush or wheel of the robotic vacuum cleaner. Failure to do so may result in personal injury.

⚠ Do not place the product near fire or flammable/explosive/corrosive materials.

⚠ If the user manual is missing, please contact your local dealer or call the after-sales service department to obtain an electronic user manual.

Safety precautions

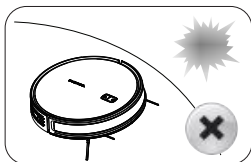

- The product can only be used indoors.

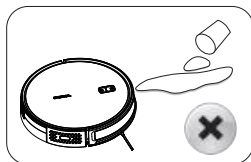

- Prevent the suction of water, oil or other liquids, which may damage the vacuum cleaner.

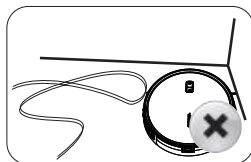

- Arrange scattered wires on the floor before use for fear of affecting the normal operation of the vacuum cleaner.

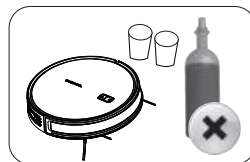

- Remove fragile objects before use.

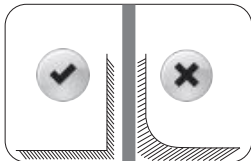

- The charging dock shall be placed against the wall and on a flat floor for fear of affecting product functionality.

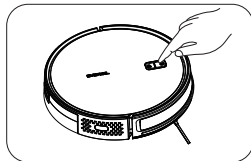

- Please wait for 15 seconds after power on. The robotic cleaner is checking.

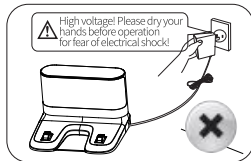

- Unplug the charging dock if it remains unused for a long time.

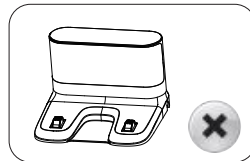

- When the product is working, removal of the charging dock will affect the normal recharging of the machine.

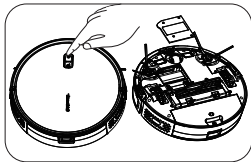

- Please turn off the power switch when the robot cleaner is not in use, so as to avoid damage to the battery. It is required to use the manufacturer's original battery, otherwise damage or accident may occur.

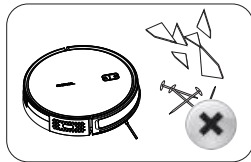

- Do not use the product to suck in sharp objects (e.g. shattered glass and nails) for fear of damage to the product.

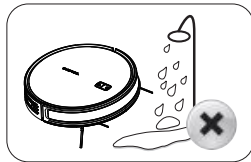

- Do not use the product in a wet, flammable, explosive or corrosive environment.

Child safety

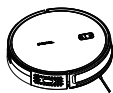

* Children under the age of 8 are not allowed to use this product. Persons with physical, sensory or intellectual disabilities or lack of relevant experience/ knowledge cannot use the machine unless under supervision, operating instructions or awareness of the danger. Children are not allowed to play with the machine or clean/repair the machine unless under supervision.

* Children are not allowed to play with the product's packaging bag for fear of suffocation.

About the batteries



1. Only the batteries provided by the manufacturer are applicable to the product.
2. Be sure to turn off the power switch before taking out the battery.
3. The batteries shall be removed when the product is discarded.
4. If you need to replace the battery of the host machine, please contact our after-sales service department. Use of wrong batteries may cause a safety accident.
5. If the batteries leak, prevent the contact of the liquid with the skin or clothing. Immediately wipe it with a dry cloth and send it to the recycling station or designated maintenance point. Do not discard it.
6. Please properly dispose of the old batteries of the product. The batteries contain hazardous substances harmful to the environment. Please follow the local environmental regulations and send them to the designated recycling site.

Scope of use

*The product is suitable for the following floors:



Wooden floor



Ceramic tile



Short-staple carpet

Disclaimers

Under any of the following circumstances, the product will be excluded from the scope of free warranty, but paid repair can be provided:

- A. Damage due to the user's failure to operate the product in strict accordance with our user manual or due to improper storage;
- B. The machine or parts have exceeded the free warranty period;
- C. Damage due to disassembly by those other than the maintenance personnel of our company or authorized by our company;
- D. A valid purchase voucher number cannot be provided;
- E. The product model on the warranty card does not match that of the product to be repaired or is altered;
- F. Damage caused by irresistible factors such as natural disasters;
- G. Product failure or damage caused by unexpected factors or man-made causes (including operational errors, liquid ingress, improper plugging/unplugging, scratching, handling, bumping, input of inappropriate voltage, etc.)

Note: Our company provides a warranty for the product in accordance with the "National New Regulations on Warranty". For details, please check the warranty card provided with the product.

Product Appearance

Main machine

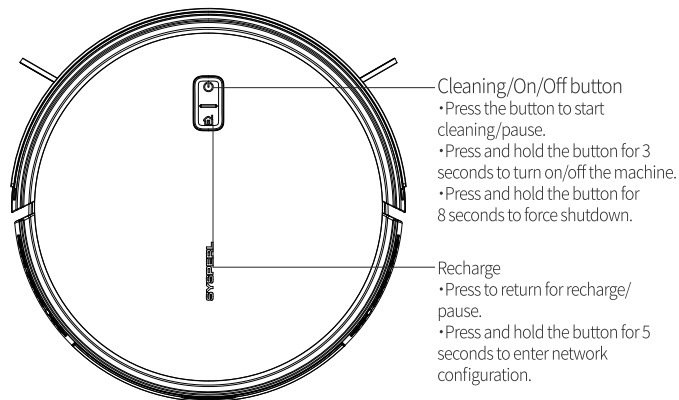
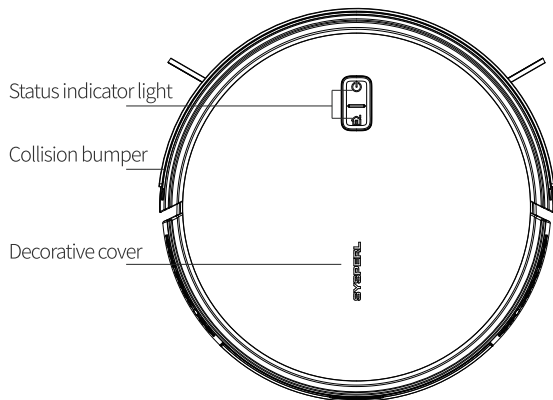

Notes:

- During cleaning, recharge or partial cleaning, press any button to pause the current task.
- Press and hold the recharge button and the collision buffer at the same time for 10s until the power indicator light goes out to enter the CEC test mode.

Main machine

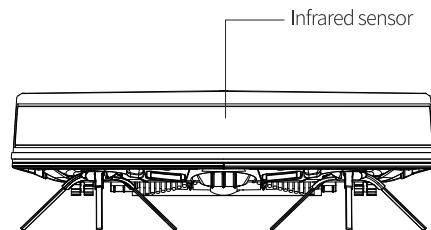
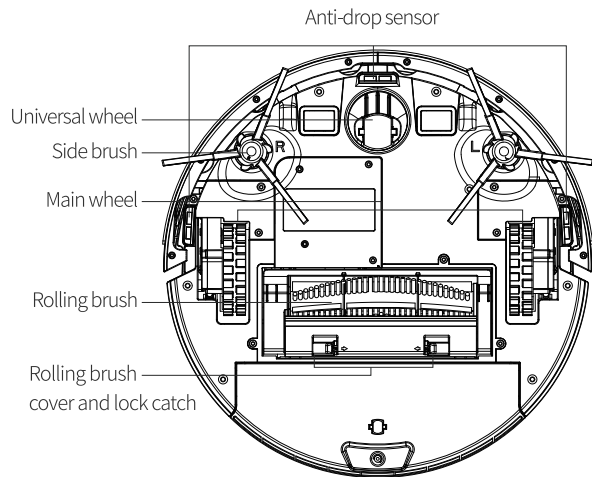

Dust box

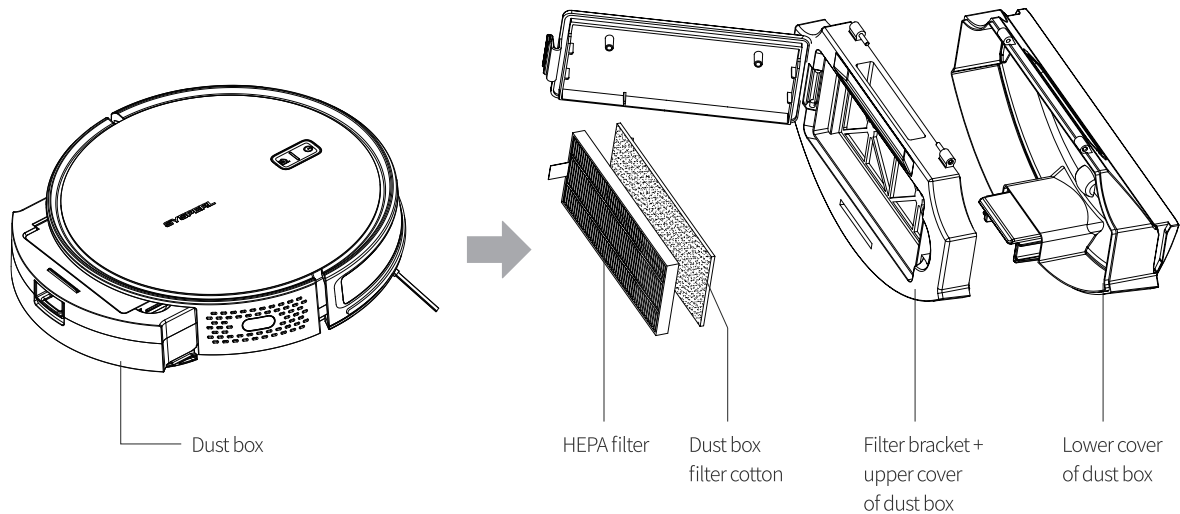

Charging dock

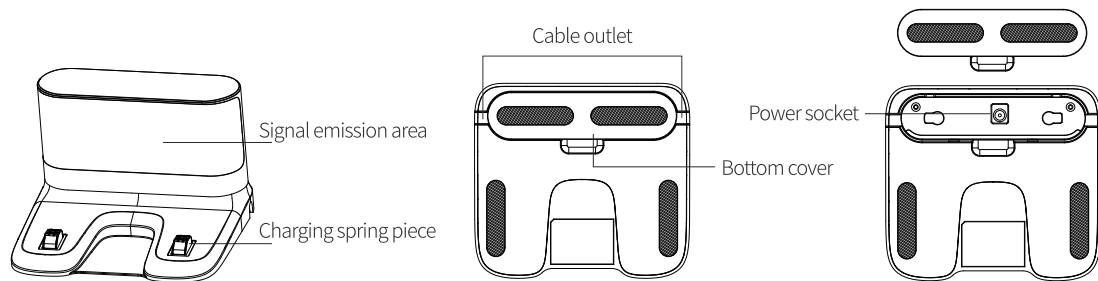

Product List

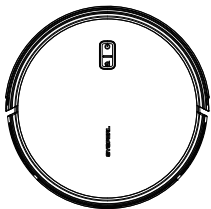

Main machine x1



Charging dock x1

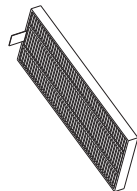

HEPA filter x2



Cleaning brush x1



Remote control x1

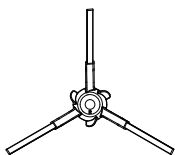

Right side brush x2

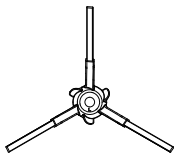

Left side brush x2

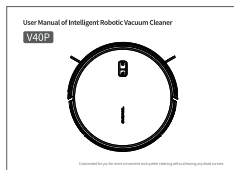

User manual x1

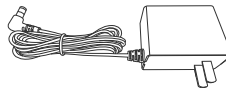

Power adapter x1

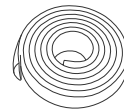

magnetic strip x1

Installation Instructions

1) Connect the power cord, put the excess wire into the wire slot, and remove the lens protective film before use.

Notes:

- The power cord hanging on the floor may be dragged by the main machine, causing power disconnection of the charging dock.
- When the machine is charged, the indicator light of the machine flashes intermittently.

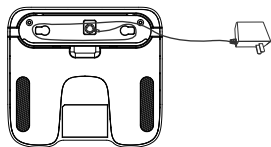

3) To facilitate the cleaning and better recharging of the main machine, please do not move the charging dock randomly and frequently. If the position of the charging dock is changed, the main machine may lose the position memory of the charging dock. When recharging again, it will relocate and search for the charging dock.

Note:

- Avoid direct sunlight.

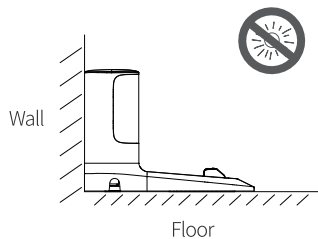

2) Place the charging dock on the level floor and connect it to the power source.

Note: Please make sure that there is space of more than 0.5 meters on both sides of the charging dock, and more than 1.5 meters in front.

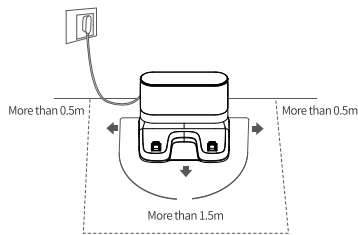

4) Before use, please remove the protective strip and protective film on the front bumper of the device to ensure the normal use of the device.

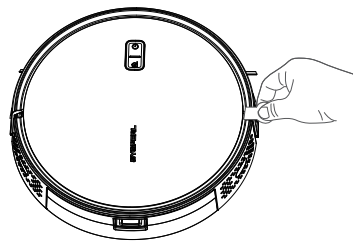

5) Turn on and charge

Press and hold the button  to turn on the main machine, and the indicator light flashes slowly. Place the main machine within one meter directly in front of the charging dock, click on the button , and the main machine will automatically search for the charging dock and proceed to charge.

Note: The machine cannot be turned on if the battery level is low. Please place the main machine on the charging dock, and it will automatically turn on. The main machine can be turned on, and work normally when its battery level is $\geq 12\%$.

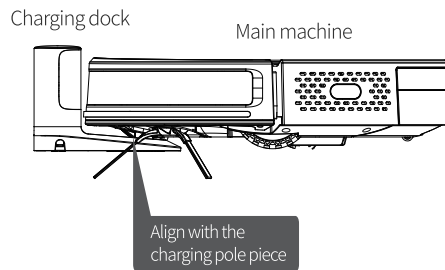

Remote Control Instructions

Product appearance

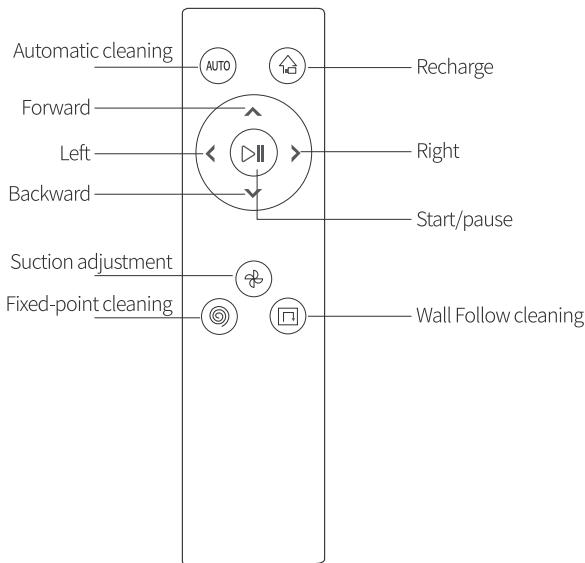

Remote control battery instructions

- Dry battery specifications: AAA

Button operation instructions

Button	Operation	Function Description
Cleaning startup/ pause button	Press it (when the machine is paused).	Start cleaning (continue cleaning if there is a cleaning task, and start the automatic cleaning mode if there is no cleaning task).
	Press it (when the machine is operating).	Pause/stop: including cleaning pause and recharging stop.
Forward button	Press it to work.	Start remote cleaning according to the received signal and move forward.
Left button		Start remote cleaning according to the received signal and rotate to the left on the spot.
Right button	Release it to stop.	Start remote cleaning according to the received signal, and rotate to the right on the spot.
Backward button		Start remote cleaning according to the received signal and move backward.
Recharge button	Press it.	Start/pause recharging.
Suction adjustment	Press it.	Press it to cycle through the suction levels.
Fixed-point cleaning	Press it.	Fixed-point cleaning: It starts spiral cleaning with the current position of the robotic cleaner as the starting point, and returns to the starting point to end the cleaning when it hits an obstacle or the diameter reaches 1 meter.
Wall Follow cleaning	Press it.	The main machine moves straight forward, and when the wall is identified, it starts to clean along the wall. After performing cleaning twice, it automatically returns for recharge.

Main Machine Instructions

Cleaning/pause

Method 1: After turning on the machine, press and hold the button  on the main machine to start cleaning (press any button to pause during cleaning).

Method 2: Click on the cleaning button in the APP to start cleaning (press the pause button to pause the current task).

Notes:

- The robotic cleaner cannot be used to clean liquids.
- If the battery level is lower than 12%, the cleaning task cannot be performed. Please charge the battery before starting the cleaning.
- Please arrange all kinds of wires on the floor (including the power cord of the charging dock) before cleaning, so as to prevent the main machine from dragging wires or objects during cleaning, which may cause power disconnection or damage to objects or wires.

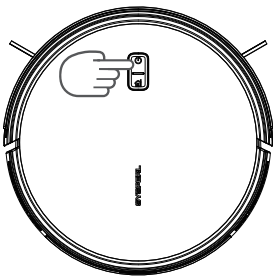

Method 1

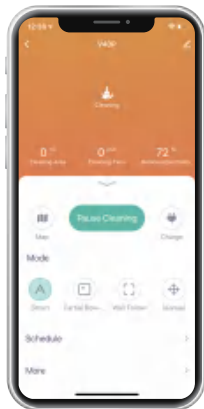

Method 2

Automatic cleaning

The main machine starts to clean in a bow-shaped path. After the entire room is cleaned, it enters the Wall Follow cleaning mode. After performing Wall Follow cleaning twice, it automatically returns for recharge.

Charging

Automatic mode: After the cleaning is over, the device will automatically return to the charge dock for charging.

Manual mode: In the pause state, press the button  to start recharge, or start recharge in the App. The indicator light flashes intermittently when the device is charged.

Note: If the device fails to find the charge dock, please manually put the main machine back onto the charging dock for charging.

Cleaning of designated rooms with magnetic strips (optional)

When you want to specify a room for separate cleaning, the robotic cleaner will not go beyond the magnetic strip and will clean the current room separately if a magnetic strip is placed at the door of the designated cleaning room.

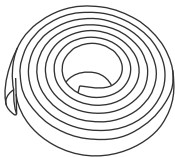

Timed cleaning

You can use the mobile App to preset the cleaning time, and the main machine will automatically start cleaning at the specified time, and automatically return to the charging dock to charge after the cleaning is over.

Reset Wi-Fi

When the mobile phone cannot connect to the device due to change of configuration or password of the router or other reasons, please press and hold the button  for 5 seconds until there is a voice prompt "Wi-Fi has been reset", and the Wi-Fi indicator light turns to blue and flashes fast, indicating that the reset is successful. (Figure 1)

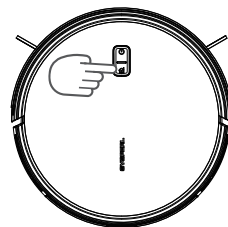

(Figure 1)

Cleaning mode

Use the mobile App to choose Automatic, Wall Follow or Fixed-point cleaning.

Daily Maintenance

Dust box and filter

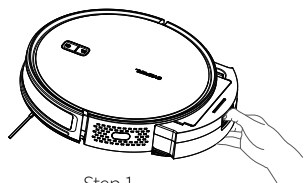

Step 1

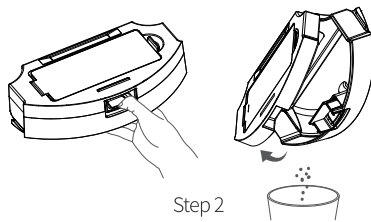

Step 2

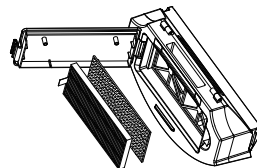

Step 3

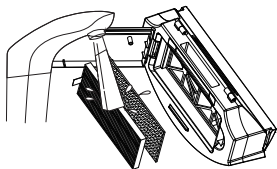

Step 4

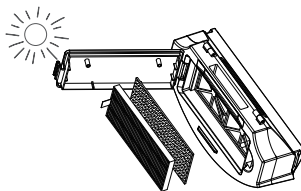

Step 5

Step 1: Press the button to take out the dust box.

Step 2: To avoid spilling of garbage, keep the dust box mouth up. Hold the transparent dust box with your right hand, open the lock catch of the dust box upper cover with your left hand, and pour out the garbage. To avoid clogging of the filter, please knock the dust box lightly when emptying it (It is advisable to clean it after each cleaning, at least once a week).

Step 3: After a long period of use, remove the filter assembly (It is advisable to replace the filter assembly every 6-12 months to ensure good cleaning effect of the device).

Step 4: Rinse the dust box and filter (not too frequently but advisably monthly).

Step 5: After rinsing, shake off water droplets vigorously. Please be sure to wait until the dust box and filter are completely air-dried before using it to ensure its service life.

Note: • Please rinse with clean water. Do not add any detergent. Do not clean the filter with a brush or fingers.

• Do not put an incomplete dust box into the device to avoid accidentally triggering the cleaning operation and causing the air duct of the machine to be blocked and damaged.

Main brush (to be cleaned every week)

- 1) Turn over the device and press the lock catch on the main brush cover to open the main brush cover and take out the main brush.
- 2) Use the blade from the provided cleaning tool set to cut off the hair wrapped around the main brush.
- 3) The main brush bearings on both sides of the main brush can be removed to facilitate taking out the hair entangled in the gaps at both ends.

Note: It is advisable to replace the main brush every 6-12 months to ensure good cleaning effect of the device.

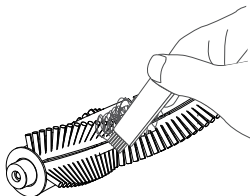

Main brush bearings

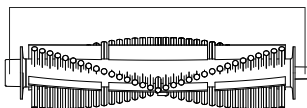

Side brush (to be cleaned every month)

- 1) Turn over the device to remove the side brush, remove the entangled hair and dirt, and then reinstall the side brush.
- 2) The hair entangled on the side brush can also be effectively removed with the blade on the dust removal brush.

Note: It is advisable to replace the main brush every 3-6 months to ensure a good cleaning effect of the device.

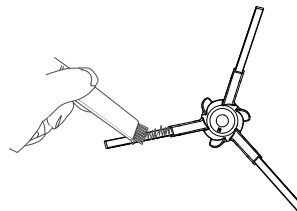
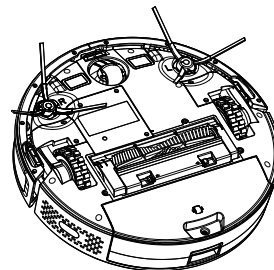

Sensor

Wipe and clean all the sensors of the main machine with a soft dry cloth, including:

- 1) Wall sensors on the left and right sides of the main machine
- 2) 3 anti-drop sensors at the bottom of the main machine
- 3) Infrared sensor protective cover

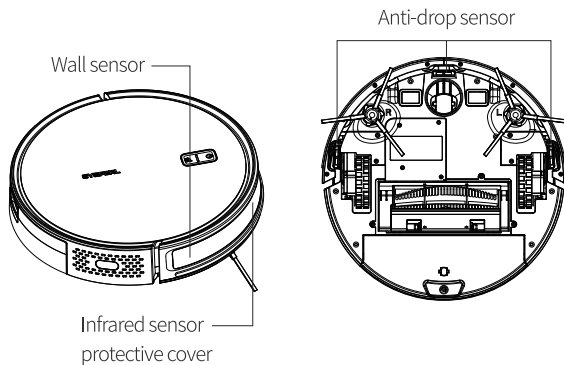

Universal wheel (to be cleaned every month)

Turn over the device and pull out the universal wheel, clean the hair and dirt on the wheel and axle, and reinstall and press it tightly.

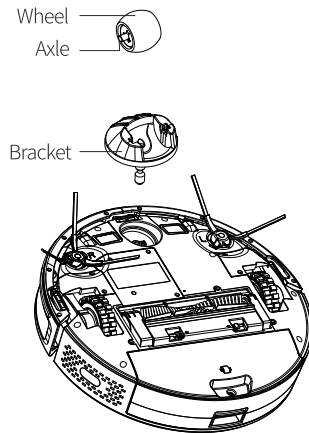

Charging pole piece

The position shown in the figure is the charging pole pieces. Please clean the charging pole pieces on the main machine and the charging dock with a dry cloth (please disconnect the power when cleaning, and it is advisable to clean them monthly).

Charging pole pieces

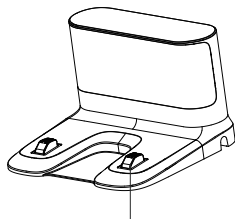
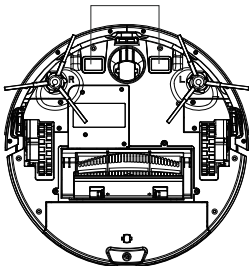

Charging spring piece

Battery

- The main machine has a built-in high-performance rechargeable lithium battery pack. To maintain battery performance, please keep the main machine in a charged state after daily use.
- If you do not use it for a long time, please turn it off for storage, and charge it at least once every three months to avoid damage to the battery due to over-discharge.

Basic Parameters

Main machine	
Dimensions	328*328*81mm
Rated voltage	14.4V $\overline{\text{---}}$
Input power	19V $\overline{\text{---}}$ 0.6A
Battery	Lithium battery
Charging time	\leq 6h
Noise	\leq 65dB (standard level)
Charging dock	
Dimensions	145*131*94mm
Rated power	12W
Output voltage	19V $\overline{\text{---}}$
Output current	0.6A $\overline{\text{---}}$

Common Faults

Fault	Cause and Solution
Startup failure	1) The battery level is low. Please place the device on the charging dock and align with the charging pole pieces, and the device will automatically turn on.
Charging failure	1) Please remove the device and check whether the indicator light of the charging dock is on, and make sure that both ends of the power adapter of the charging dock are plugged in. 2) Poor contact, please clean up the spring contacts on the charging dock and the charging contacts on the main machine. 3) Prevent the battery from being over-discharged due to long-term storage, which will lead to startup failure.
Recharge failure	1) There are lots of obstacles near the charging dock, please place the charging dock in an open area. 2) The main machine is far from the charging dock, please place the main machine near the charging dock and try again.
Abnormal operation	Shut down and restart.
Abnormal noise during cleaning	There may be foreign matter entangled in the main brush, side brush or wheels, please clean up after shutdown.
Decreased cleaning ability or dirt leakage	1) The dust box is full, please clean the dust box. 2) The filter is clogged, please clean or replace the filter. 3) The main brush is entangled by foreign matter. So please clean the main brush.
Failure to connect to Wi-Fi	1) The Wi-Fi signal is poor, please make sure the main machine is in a good Wi-Fi signal coverage area. 2) Wi-Fi connection is abnormal, please reset Wi-Fi and download the latest mobile APP and try again. 3) The password is entered incorrectly or the password has special characters. 4) The router is a 5G frequency band model, and this robotic cleaner only supports the 2.4G frequency band.
Timed cleaning doesn't work	Timed cleaning will be started when the battery level is low, and the remaining battery level $\geq 12\%$.
Whether the machine consumes power when it is placed on the charging dock all the time	When the power consumption is very low when the main machine is placed on the charging dock all the time, which helps to keep the battery in the best performance state.
Whether the machine needs to be charged for 16 hours for the first three times	Lithium battery has no memory effect when in use, and there is no need to wait when it is fully charged.

Precautions for Use

Use restrictions

- The product is only used for floor cleaning in the home environment. Do not use it outdoors (such as open balconies), in places other than the floor (such as sofas), or in commercial or industrial environments.
- Do not use it in a suspended environment (such as duplex floors, open balconies, top of furniture) without protective fences.
- **Do not use it in an environment where the temperature is higher than 40°C or lower than 0°C, or there are any liquids and viscous objects on the floor.**
- Please arrange the cables on the floor in your home before use, so as to prevent the main machine from dragging the cables during operation.
- Please put away the fragile objects and sundries on the floor (such as vases and plastic bags), so as to prevent blocking or slight collision of the main machine during operation, which may cause damage to valuables in the home.
- Do not allow people (including children) with physical, mental or sensory impairments to use or operate the product.
- Do not allow children to play with the robotic cleaner as a toy. Please supervise children and pets to stay away as much as possible when the main machine is working.
- Do not place the main brush cleaning tool in an area that children can touch.
- Do not place any objects (including children and pets) on the stationary or moving main machine.
- When the main machine is working, please do not place any part of your body, pet hair, fingers, etc. close to the suction port of the machine put.
- Do not use it to clean burning objects (such as unextinguished cigarette butts).
- Do not use it to clean long-staple carpets (some dark-colored carpets may not be cleaned normally).
- Do not allow the main machine to pick up hard or sharp objects (such as decoration waste, glass and nails).
- Please clean or maintain the main machine and charging dock when the machine is turned off or the power is off.
- Do not wipe any part of the product with a damp cloth or any liquid.
- Please use the product in accordance with the instructions of the user manual. The user shall be responsible for any loss and injury caused by improper use.

Battery and charging

- Do not use any third-party batteries, chargers or charging docks.
- Do not disassemble, repair or modify the battery or charging stock without permission.
- Do not place the charging stock near a heat source (such as a radiator).
- Do not wipe or clean the charging pole pieces with a damp cloth or wet hands.
- Do not throw away waste batteries at will, which shall be disposed of by a professional recycling agency.
- If the power cord is damaged or broken, please stop using it immediately and purchase or replace it through official channels.
- If you need to transport the product, please make sure that the main machine is turned off, and it is advisable to use the original packaging box.
- If the product is not in use for a long time, please turn off the main machine after fully charging it and store it in a cool and dry place, and charge it at least once every three months to avoid over-discharge of the battery.

Fault list of the robotic vacuum cleaner

Name	Fault
Main machine	The functions listed in the manual are invalid. Startup failure The main brush, the side brush, the fan or the main wheel does not work.
Power adapter	Failure to supply power to the charging dock normally.
Charging dock	Failure to supply power to the main machine normally.

Troubleshooting

Fault Prompt Voice and Light Display	Cause Analysis and Suggested Solution
Error 0: There is a voice prompt "Please put back the dust box and start again", and the Start button and the Recharge button light up in red and flash slowly at the same time.	Cause: Cleaning is triggered when the dust box is taken out.
Error 1: There is a voice prompt "Please wipe the cliff sensor and move it to a new position to start", and the Start button and the Recharge button light up in red and are normally on at the same time.	Cause: The device is picked up; or the device is suspended in the air.
Error 2: There is a voice prompt "Please wipe the cliff sensor and move it to a new position to start", and the Start button and the Recharge button light up in red and are normally on at the same time.	Cause: The anti-drop sensor is blocked or it is put in a high place.
Error 3: There is a voice prompt "Please check and remove foreign objects out of the way of the collision sensor", and the Start button and the Recharge button light up in red and are normally on at the same time.	Cause: Its edge or collision sensor is stuck.
Error 4: There is a voice prompt "As the charging is abnormal, please clean the charging contact area", and the Start button and the Recharge button light up in red and flash slowly at the same time.	Cause: Excessive wear of the charging pole pieces of the robotic cleaner, resulting in poor contact.
Error 5: There is a voice prompt "As the fan is abnormal, please check and clean the filter", and the Start button and the Recharge button light up in red and are normally on at the same time.	Cause: The fan of the robotic cleaner is blocked.
Error 6: There is a voice prompt "As the battery level is too low, please put it back onto the charging dock to charge", and the Start button and the Recharge button light up in red and are normally on at the same time.	Cause: The cleaning is triggered (the battery is charge level is less than 5%) when the battery level is extremely low and the main machine is not on the charging dock.
Error 7: There is a voice prompt "Please place the device on the level floor to start", and the Start button and the Recharge button light up in red and are normally on at the same time.	Cause: The machine is tilted.
Error 8: There is a voice prompt "As the left drive wheel is abnormal, please check and clean the drive wheel", and the Start button and the Recharge button light up in red and flash slowly at the same time.	Cause: The left wheel is stuck or entangled.
Error 9: There is a voice prompt "As the right drive wheel is abnormal, please check and clean the drive wheel", and the Start button and the Recharge button light up in red and flash slowly at the same time.	Cause: The right wheel is stuck or entangled.
Error 10: There is a voice prompt "As the main brush is abnormal, please check and clean the main brush", and the Start button and the Recharge button light up in red and flash slowly at the same time.	Cause: The main brush is entangled or stuck.
Error 11: There is a voice prompt "As the side brush is abnormal, please check and clean up the side brush", and the Start button and the Recharge button light up in red and flash slowly at the same time.	Cause: The side brush is entangled or stuck.

When the main machine is working abnormally, the ring indicator light flashes in red quickly and a voice prompt is given. Please refer to the above table for troubleshooting.

Statement of Hazardous Substance Content Status

Toxic and Hazardous Substances and Elements	Component Name					
	Plastic shell	Circuit board assembly	Power cord	Battery	Metal parts	Power adapter
Lead (Pb)	○	×	×	×	○	×
Mercury (Hg)	○	○	○	○	○	○
Cadmium (Cd)	○	○	○	○	○	○
Hexavalent chromium (Cr(VI))	○	○	○	○	○	○
Polybrominated biphenyl (PBB)	○	○	○	○	○	○
Polybrominated diphenyl ethers (PBDE)	○	○	○	○	○	○

Environmental service life of each component: 10 years for circuit board assembly, 10 years for the power cord, and 5 years for the battery. The environmental service life marked on the product refers to the safe service life during which leakage of toxic and hazardous substances will not occur to the product under the operating conditions specified in this user manual.

○: It indicates that the content of the toxic and hazardous substance in all homogeneous materials of this part is below the required limit specified in SJ/T11363-2006.

×: It indicates that the content of the toxic and hazardous substance in at least one of the homogeneous materials of this part exceeds the required limit specified in SJ/T11363-2006.



Remarks: The lead content in a small number of special-purpose SMD electronic components (such as high voltage resistors, ceramic resistors and diodes) in the parts marked “×” in the table may be $\geq 0.1\%$. As the screws and cores of data cables are made of alloys with better performance, their lead content may also be $\geq 0.1\%$. These components are in conformity to the exemption clauses specified in the EU RoHS Directive. Due to the limitations of the global technology development level at present, there are no alternative technologies and components, but the lead content of all the external contact parts of the product meets the environmental requirements.

Warranty Card



SYSPERL™

WARRANTY CERTIFICATE

ACTIVATE WARRANTY



SCAN QR CODE TO ACTIVATE WITHIN
14 DAYS , OR ACTIVATE BY VISITING
WWW.SYSPERLSHOP.COM



WARRANTY CARD

SHOP AMAZON: ALIEXPRESS:

ORDER NUMBER: _____

PRODUCT MODEL
NUMBER/NAME: _____

DATE OF PURCHASE: _____

NAME: _____

ADDRESS: _____

E-MAIL: _____

PHONE: _____

SIGNATURE: _____

DATE: _____

Must return within 30 days of purchase
with copy of dated register receipt.
Please make a copy of this for yourself, and mail to :
support.us@sysperlshop.com

CONFORMITY CERTIFICATE

Model: _____

Inspector: _____

Date of manufacture: _____