

SOLACE OTTOMAN TV BED

SIZE : 4ft6 & 5ft

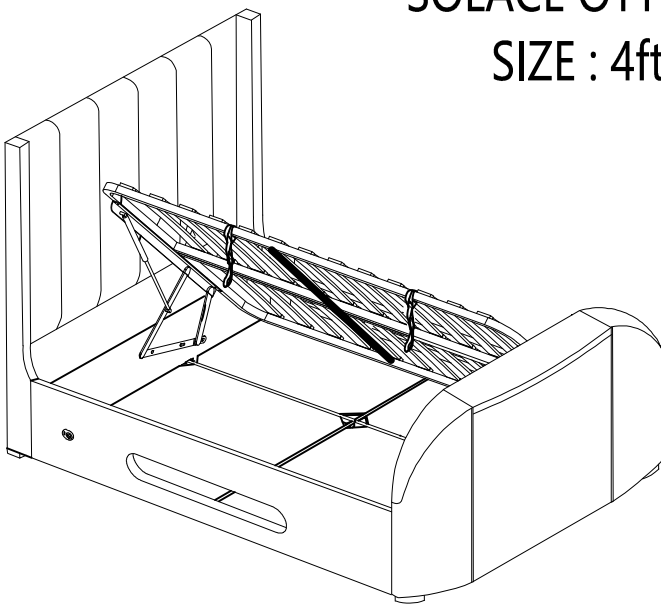

PLEASE READ this sheet prior to assembly to familiarise yourself with the various stages of construction. Carefully open the pack supplied and check the contents against the parts and fittings check list.

Do not destroy any of the packaging until you are certain that you have all the necessary parts for the assembly.

Please ensure that the packaging is disposed of in a safe environmentally friendly way.

CAUTION: There are small components used in the construction of this unit. These loose items should be kept away from young children during assembly, to avoid the danger of choking.

IMPORTANT: BEFORE STARTING TO ASSEMBLE THE BED - PLEASE READ THESE INSTRUCTIONS CAREFULLY

Parts Identification

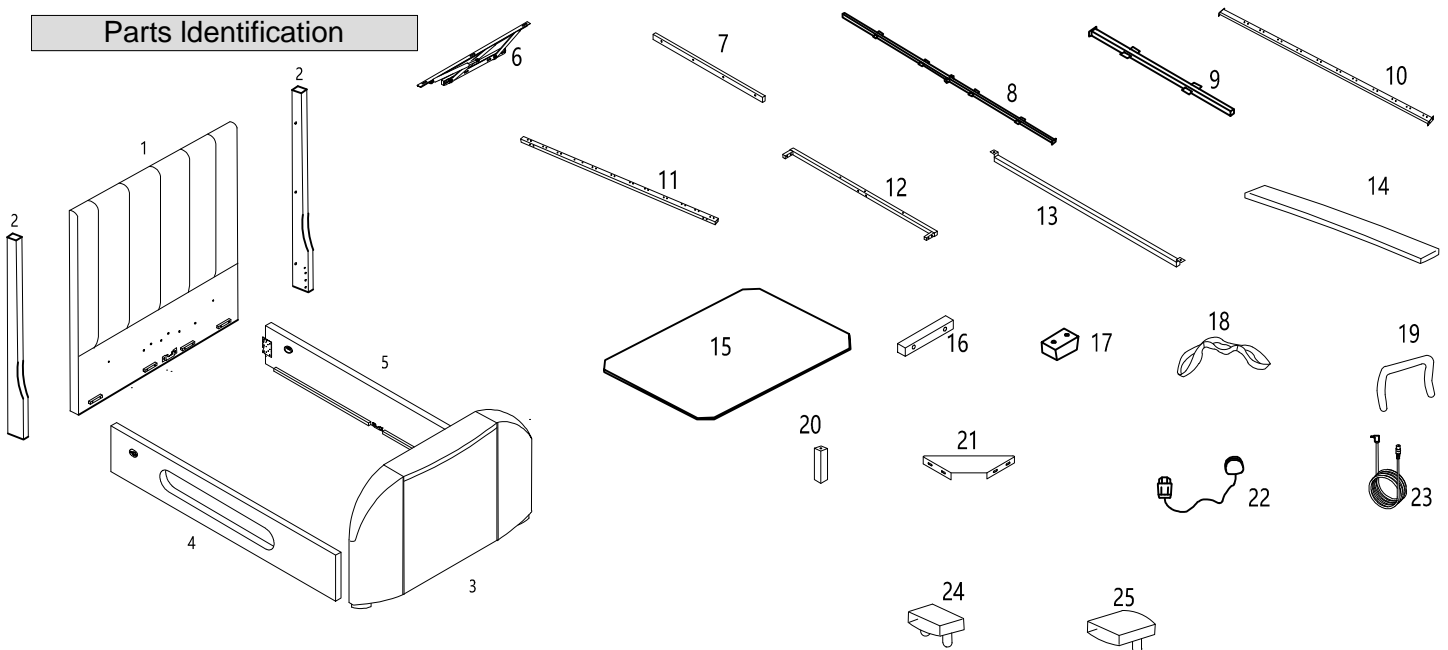

Parts Identification

Ref.	Description	Qty	Ref.	Description	Qty
1	Headboard	1	14	Slats	28
2	Headboard's Wing	2	15	Storage Board	4
3	Footboard	1	16	Wooden (FB)	4
4	Side Rail (Left)	1	17	Headboard Foot	2
5	Side Rail (Right)	1	18	Strap	2
6	Lift Up Mechanism	2	19	Mattress Stopper	2
7	Wooden	2	20	Center Support Leg	1
8	Bottom Cross Bar (Long)	1	21	Metal Corner Plate	4
9	Bottom Cross Bar (Short)	2	22	Main Power Lead	1
10	Support Bar	1	23	Aerial Lead 4 meter	1
11	Metal Frame Long	2	24	Single Plastic Cap Side	28
12	Metal Frame Short	2	25	Double Plastic Cap Center	14
13	Center Support Bar	1			

Fittings Checklist

Code	Description	Qty	Code	Description	Qty
A	Bolt (M8x16mm)	x14	I	Screw (M5x50mm)	x4
B	Bolt (M8x30mm)	x26	J	Bolt (M6x15mm)	x2
C	Bolt (M8x40mm)	x9	K	Flat Washer (M8x17mm)	x2
D	Bolt (M8x45mm)	x6	L	Allen Key M5	x1
E	Bolt (M8x60mm)	x6	M	Spanner M14	x1
F	Nut (M8x13mm)	x12	O	Non-slip Pad	x1
G	Flat Washer (M8x22mm)	x6			
H	Screw (M4x35mm)	x8			

Additional Tools Required

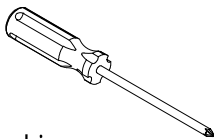

Cross-head Screwdriver

General Hints & TIPS

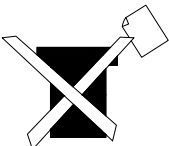

Please retain your assembly instruction and tools provided for future use. Periodically check that all bolts are still tight.

Assembly requires two persons.

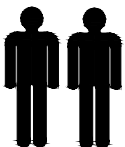

1.5 HOUR

Approximate time to assemble this product

IMPORTANT SAFETY INSTRUCTIONS

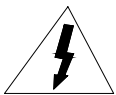

WARNING

RISK OF ELECTRIC SHOCK
DO NOT OPEN

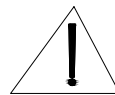

CAUTION: TO REDUCE THE RISK OF ELECTRIC SHOCK, DO NOT REMOVE COVER (OR BACK). NO USER - SERVICEABLE PARTS INSIDE. REFER SERVICING TO QUALIFIED SERVICE PERSONNEL.



The lightning flash with arrowhead symbol, within an equilateral triangle, is intended to alert the user to the presence of uninsulated "dangerous voltage" within the product's enclosure that may be of sufficient magnitude to constitute a risk of electric shock to persons.

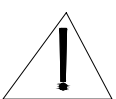



The exclamation point within an equilateral triangle is intended to alert the user to the presence of important operating and maintenance (servicing) instructions in the literature accompanying the appliance.

1. Read these instructions.
2. Keep these instructions.
3. Heed all warnings.
4. Follow all instruction.
5. Do not use this apparatus near water.
6. Clean only with dry cloth.
7. Do not block any ventilation openings. Install in accordance with the manufacturer's instructions
8. Protect the power cord from being walked on or pinched particularly at plugs, convenience receptacles, and the point where it exit from the apparatus
9. Only use attachment / accessories specified by the manufacture.
10. Unplug this apparatus during lightning storms or when unused for long periods of time
11. Refer all servicing to qualifide service personnel. Servicing is required when the apparatus has been damaged in any way, such as does not operate normally.
12. Warning to reduce the risk of electric shock, do not expose this apparatus near moisture.
13. The mains plug is used as the disconnect device, the disconnect device shall remain readily operable.
14. Unplug this apparatus when the apparatus has been damaged, then refer all servicing to Professional.

Assembly

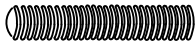
Stage 1

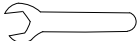
E  x6 F  x6 G  x6 M  x1

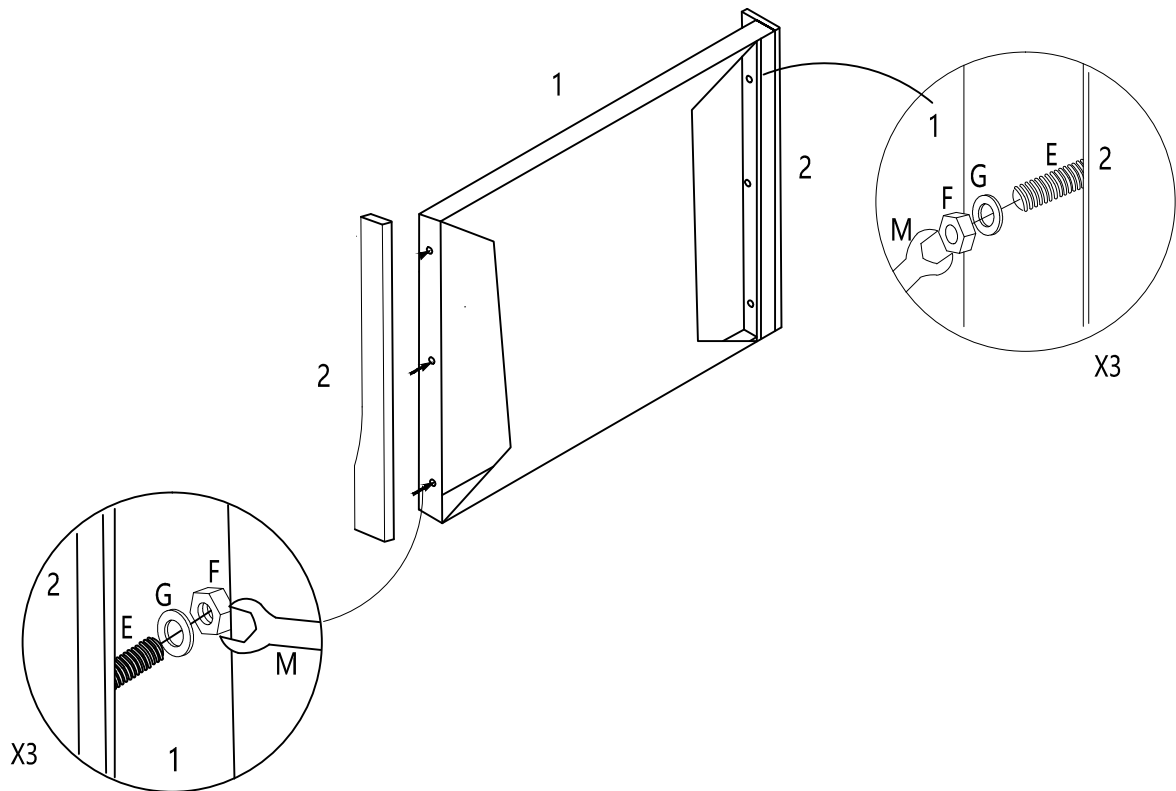

Stage 2

I  x4

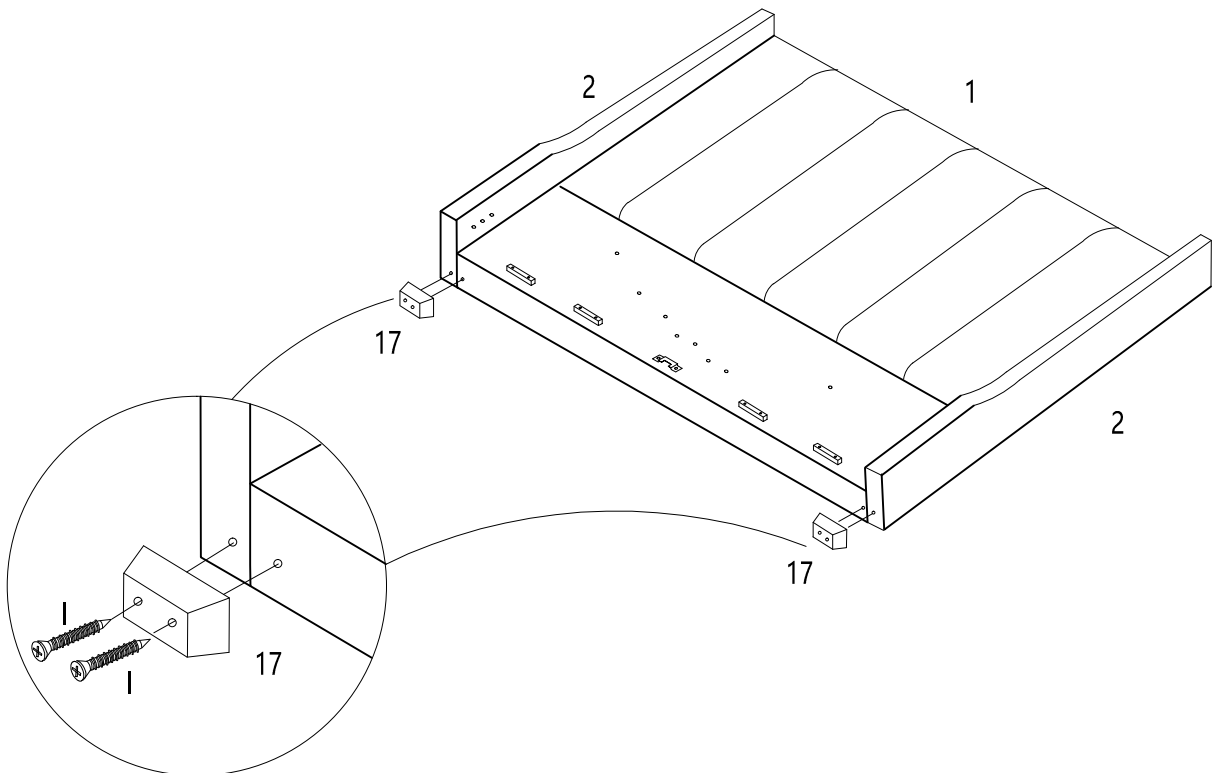

Assembly

Stage 3

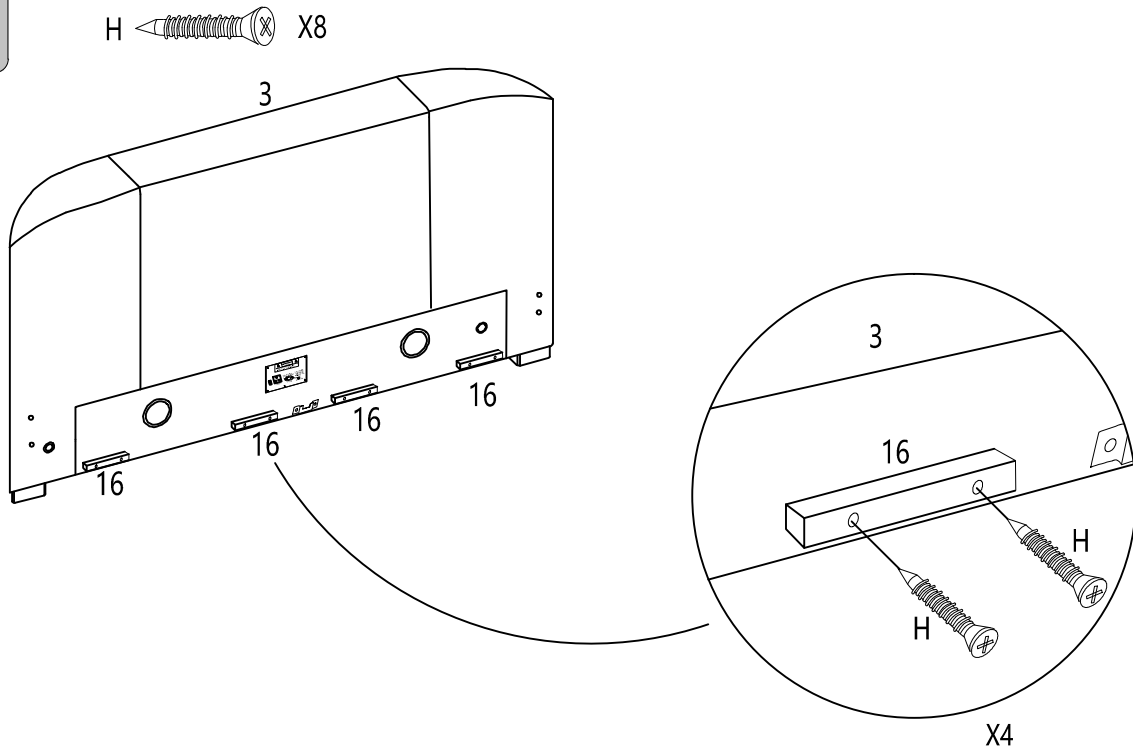

Stage 4

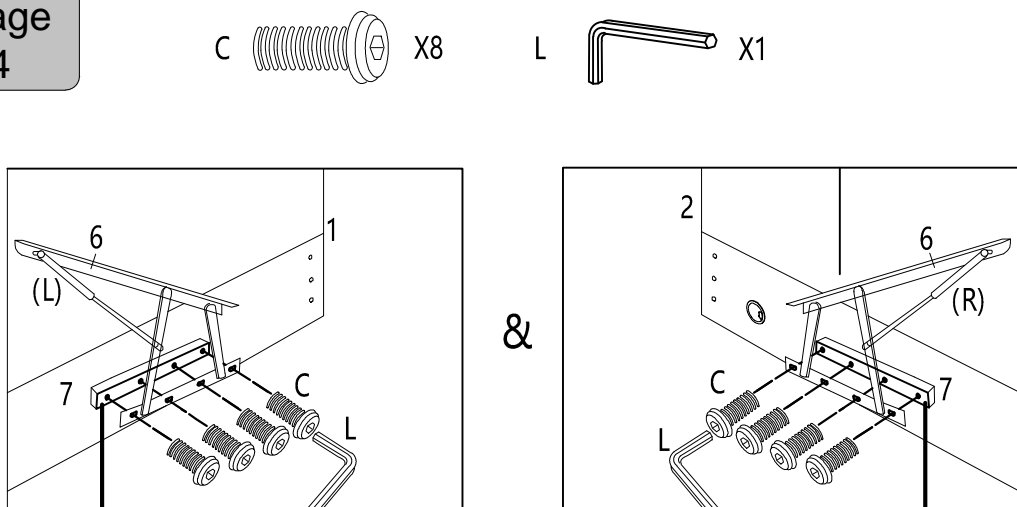

Please note:

When installing the Lift up mechanism (6), the support wood (7) must be installed first

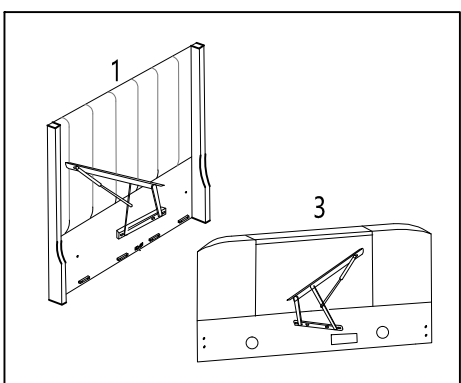

The metal frame base can be chosen to open left or right, and the gas lift mechanism can be installed left or right according to requirements.

Assembly

Stage 5

B  X10 L  X1

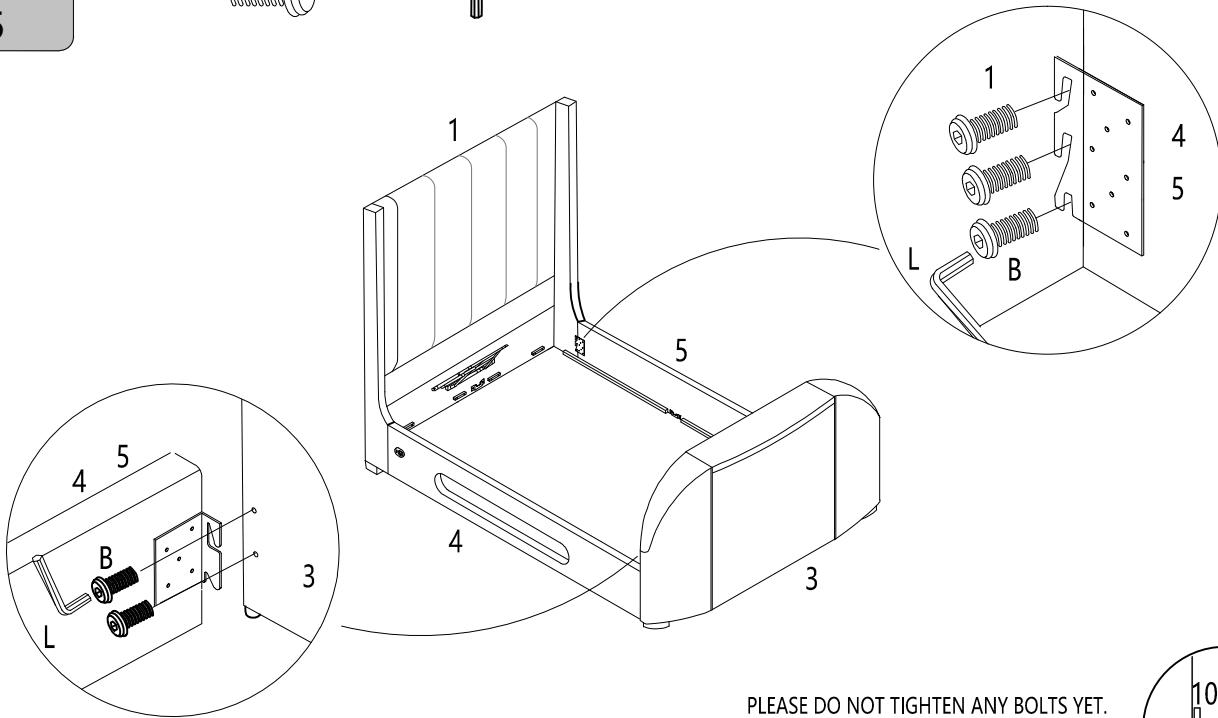

PLEASE DO NOT TIGHTEN ANY BOLTS YET.

Note: Do not tighten fully but leave 10mm protruding as in the diagram.

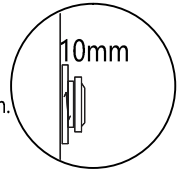

Stage 6

B  X16 L  X1

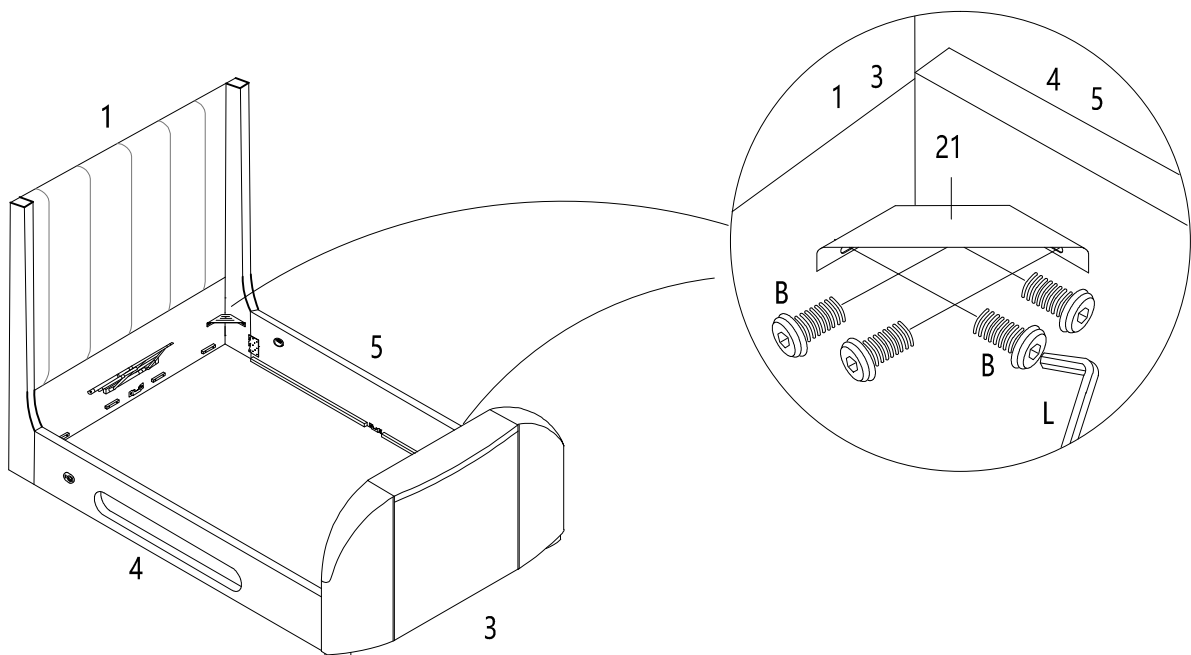

Assembly

Stage
7

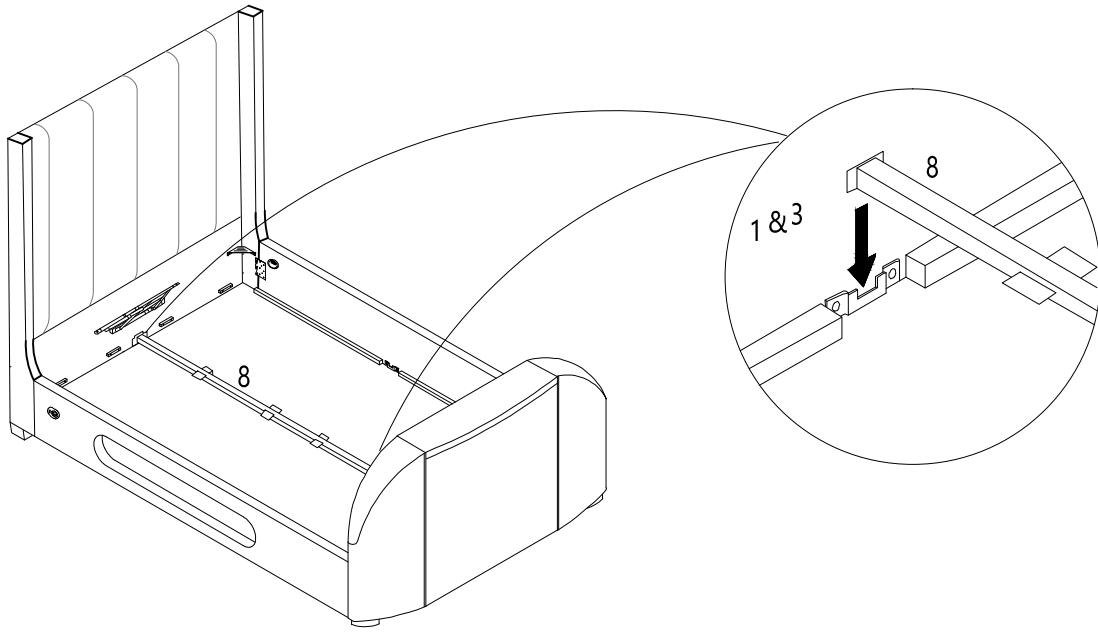

Stage
8

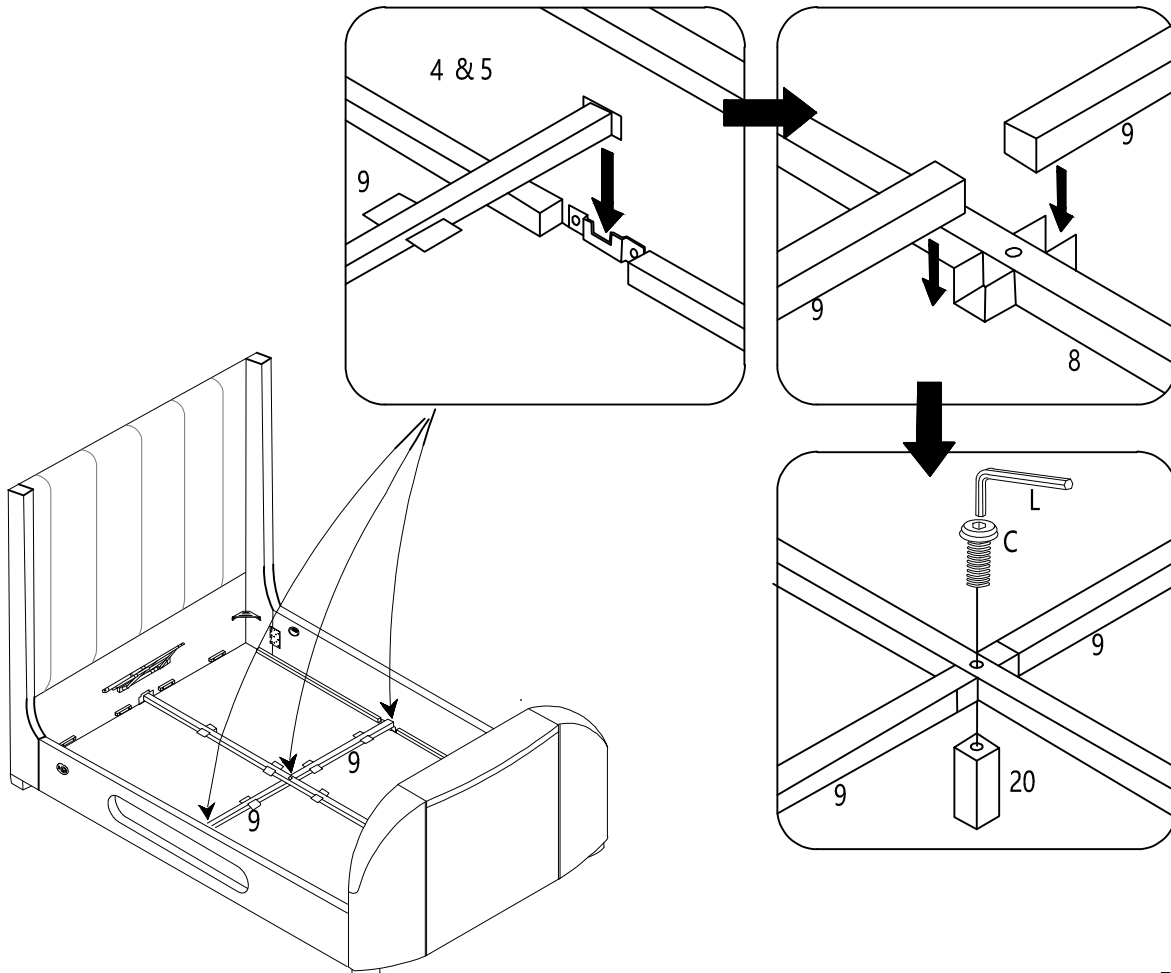

Assembly

Stage 9

Connect the Mains Power Lead (22) into the 3 Pin socket located on the right-hand side at bottom of the footboard (2). Connect UK plug to your wall socket. Note that the power supply to this plug must be earthed. The plug must be easy to reach if you need to disconnect the power at any time.

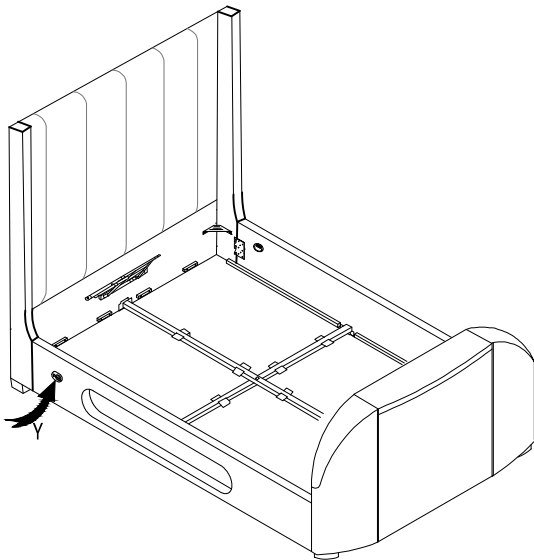
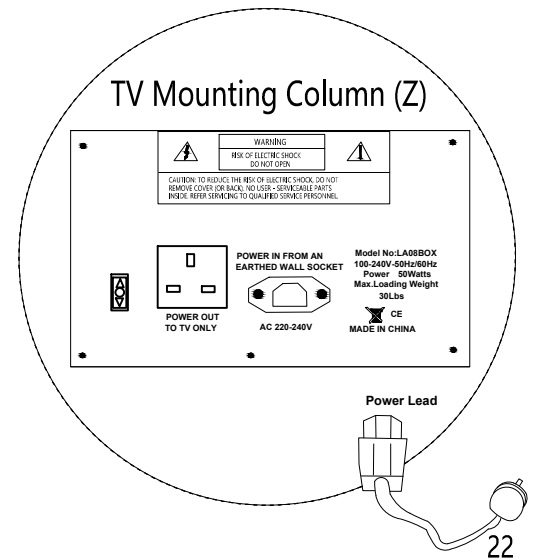

To operate the TV Mounting Column (Z) there is a switch (Y) in each side panel of the bed near the headboard (1). The switches are connected to the TV Lift control system by lift up socket on each side of the TV Mounting Column (Z) - make sure they are plugged in properly - align the arrows on the labels and push right in. One can now operate the TV Lift.

Note: If you press the Up or Down button in quick succession (1 Min) , the TV Lift does not move - this is normal, just press the button twice.

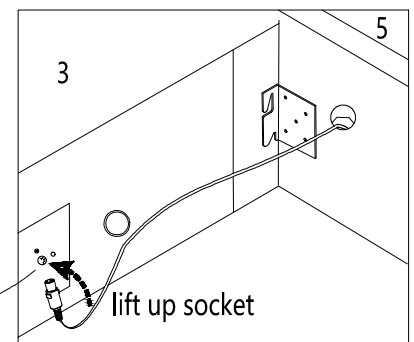
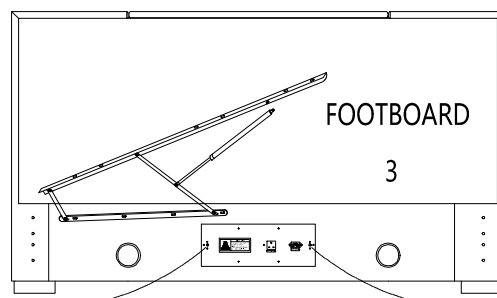
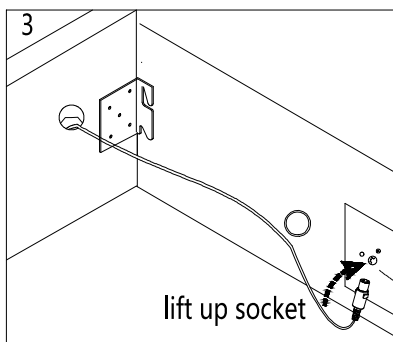
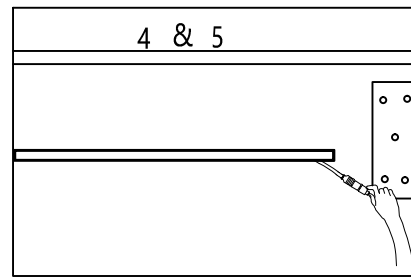
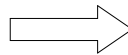
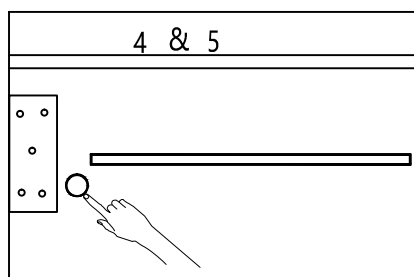

Assembly

Stage
10



Carefully remove the 2 x "VESA" screws from the back of the TV. VESA screws are used as standard screws to fit to other type of wall mountings.

Secondly, you may take out metal plate X from the TV lift mechanism and fix at the back of the TV unit by using 2 x "VESA" screws.

Connect the TV to the lift mechanism by adjusting the TV bracket located at the top of the TV lift by using the bolt (D) and flat washer (E) in your fixing bag.

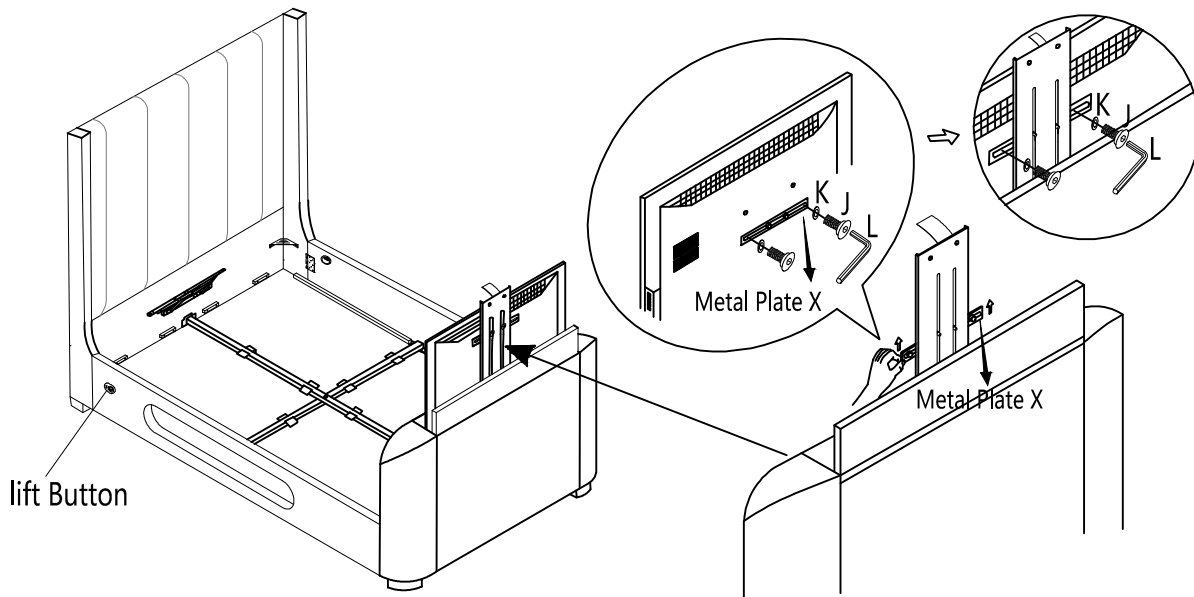

Pass the TV Power Lead, Aerial Lead through the LEFT or RIGHT duct. Choose the duct to suit connections on your TV.

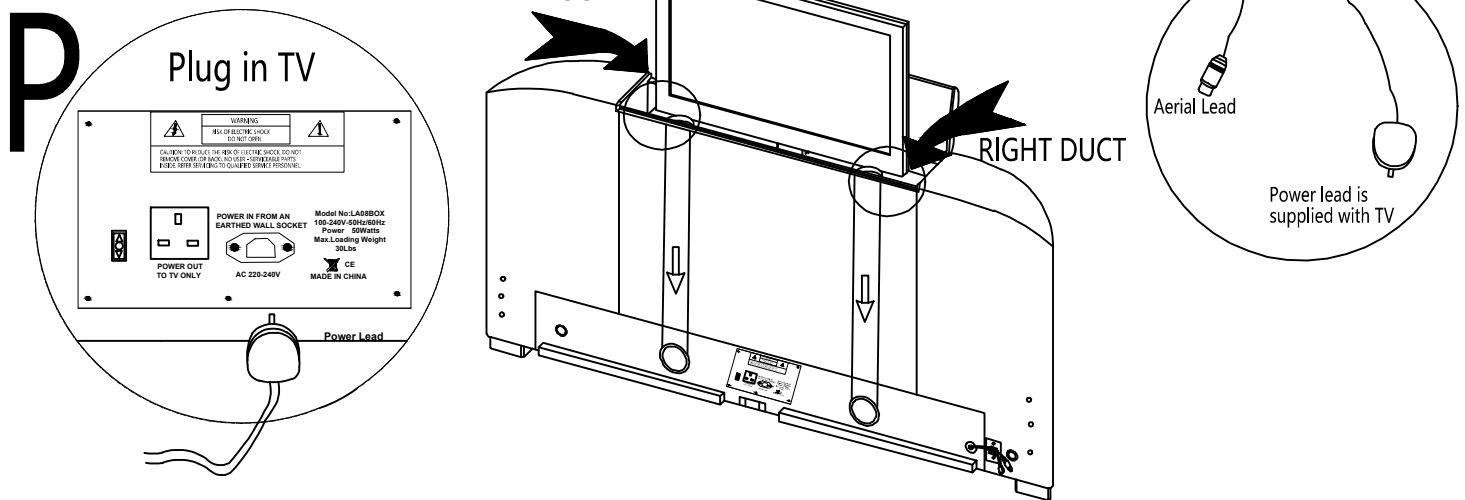

Note: Power socket for the TV is not to be used for any other equipment because it is not permanent. It cuts off power to TV when TV is down in the starting position. When TV raises up, power is restored automatically.

Assembly

Stage
11

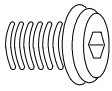
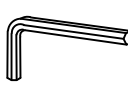
A  x12 L  x1

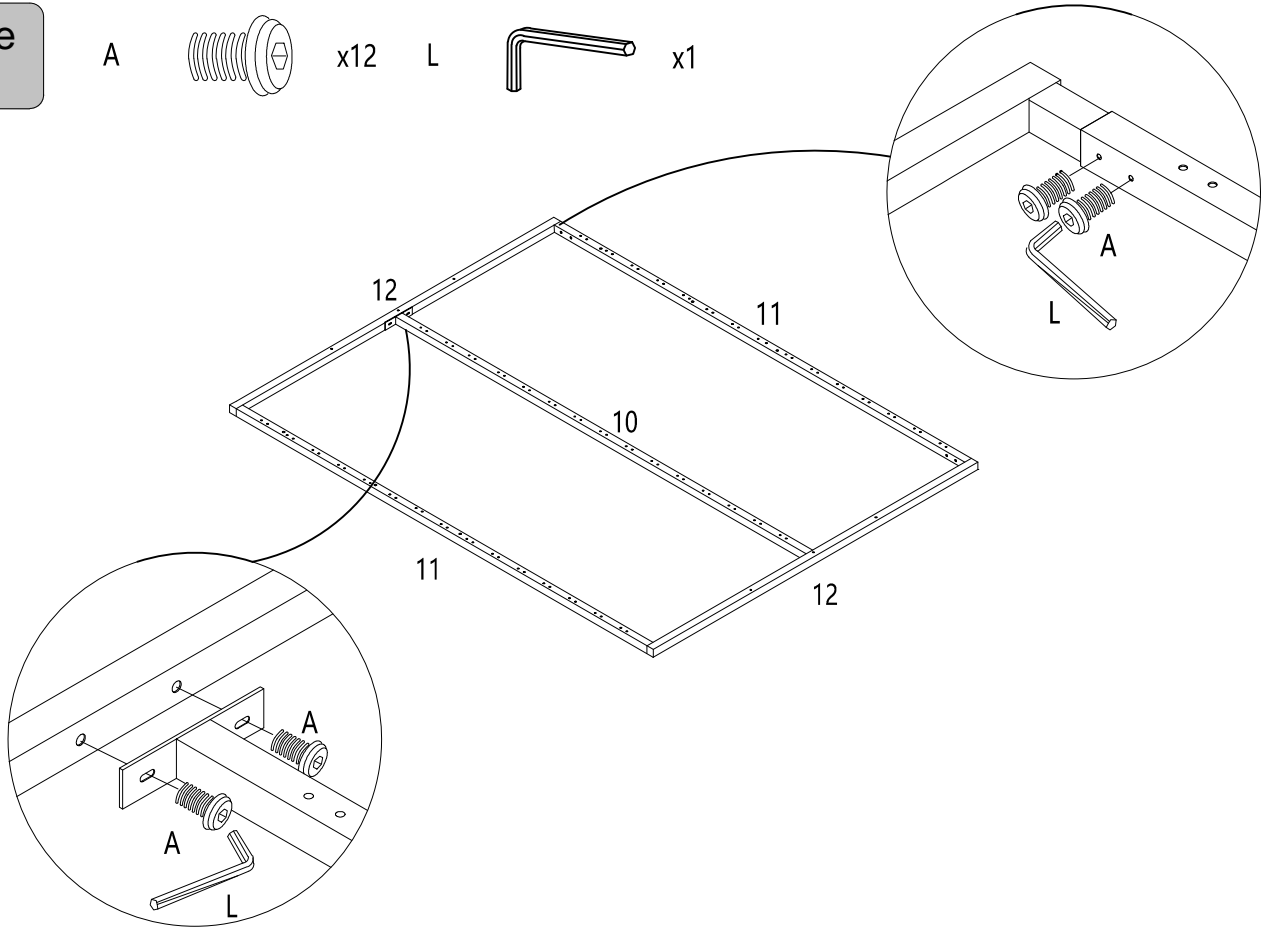

Stage
12

D  x6 F  x6 L  x1 M  x1

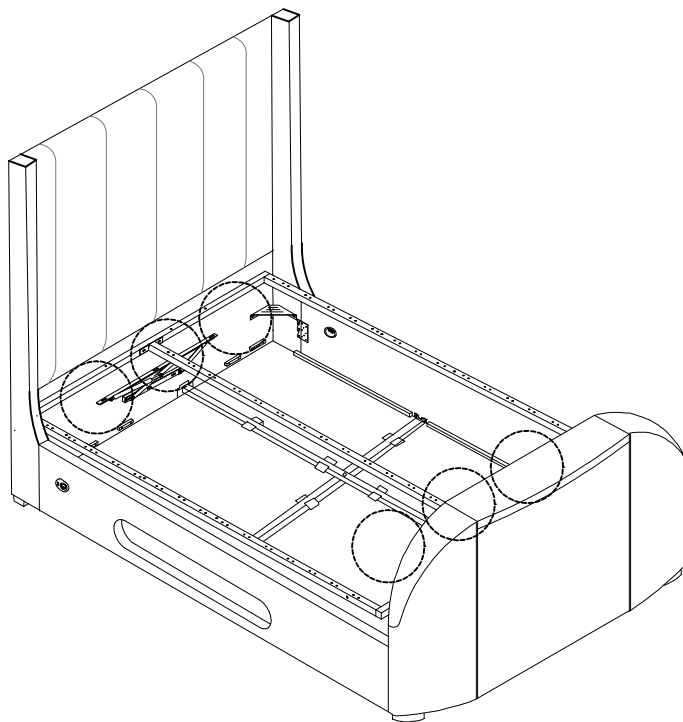

Assembly

Stage 13

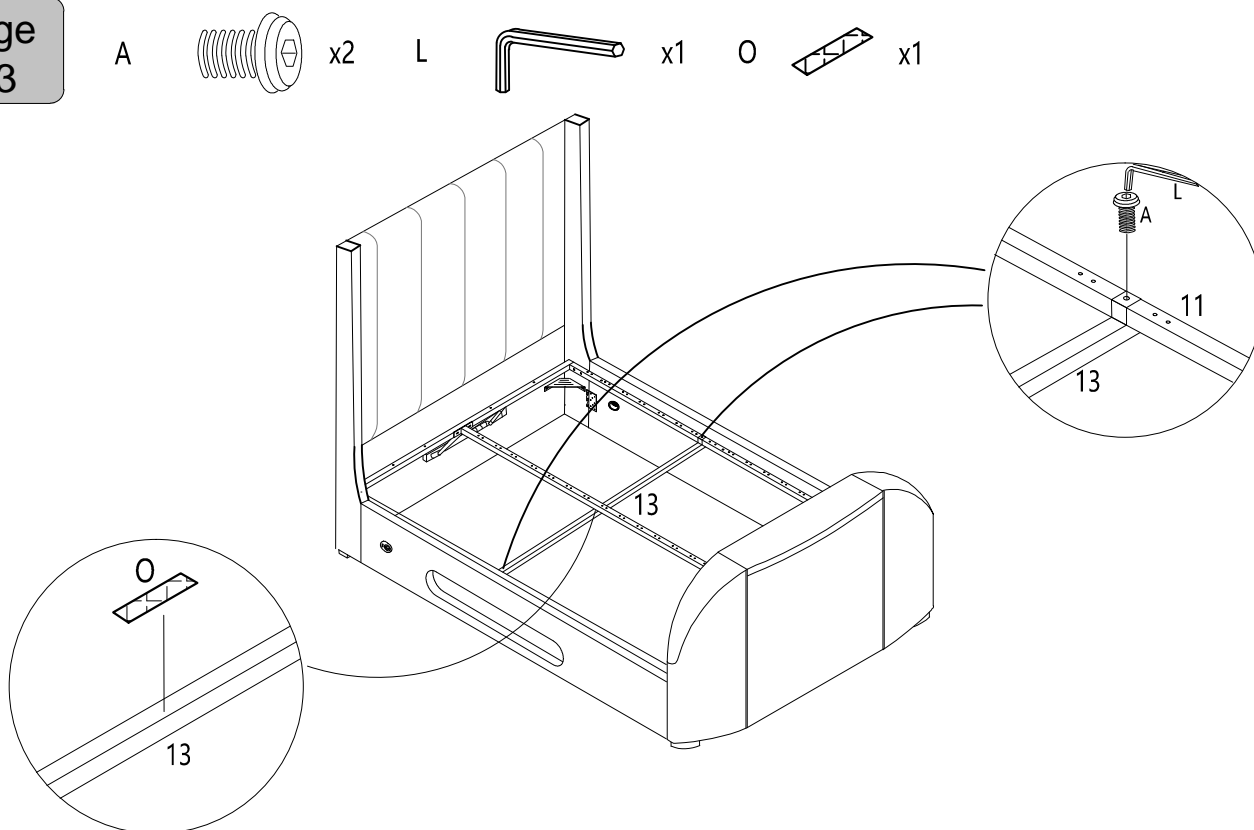

Please take note, the non-slip pad (Part O) should stick in the center of the horizontal support bar (Part 13) which overlaps with support bar (Part 10)

Stage 14

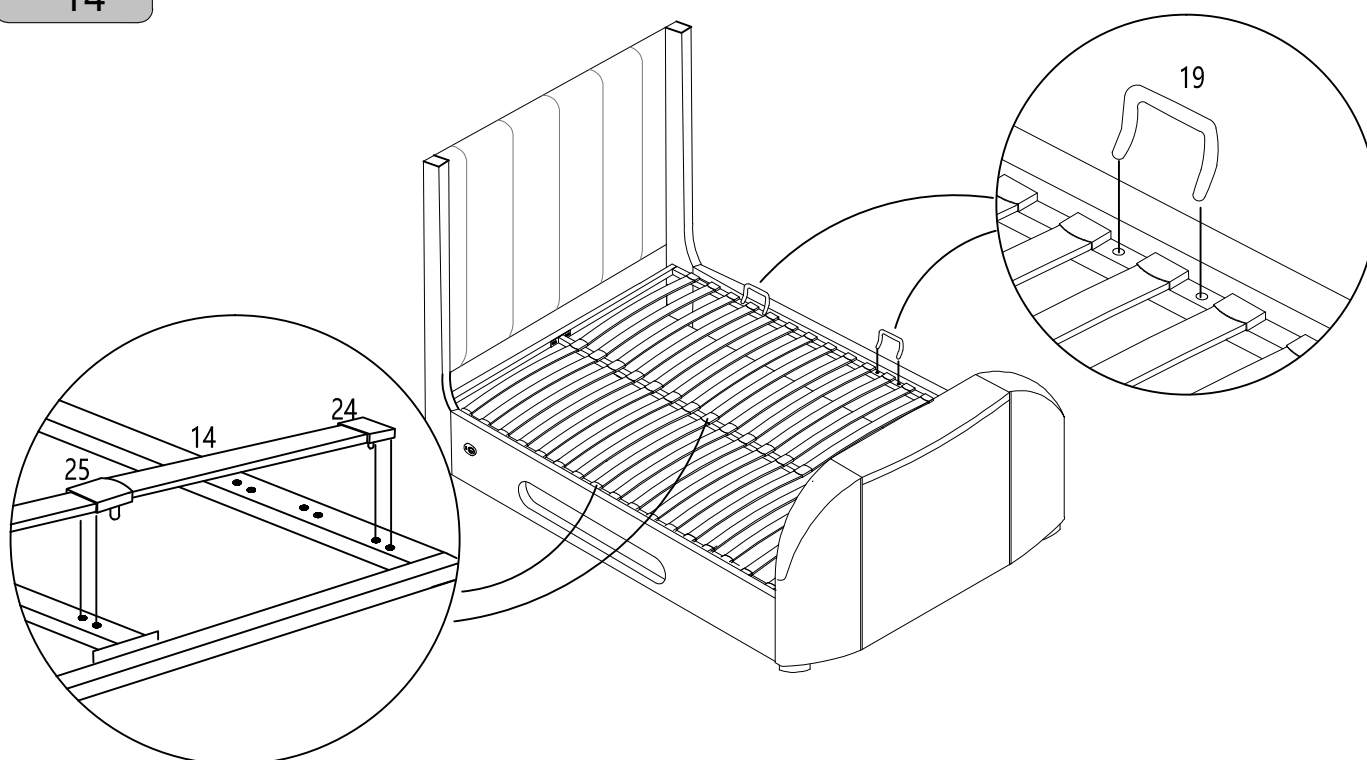

Assembly

Stage
15

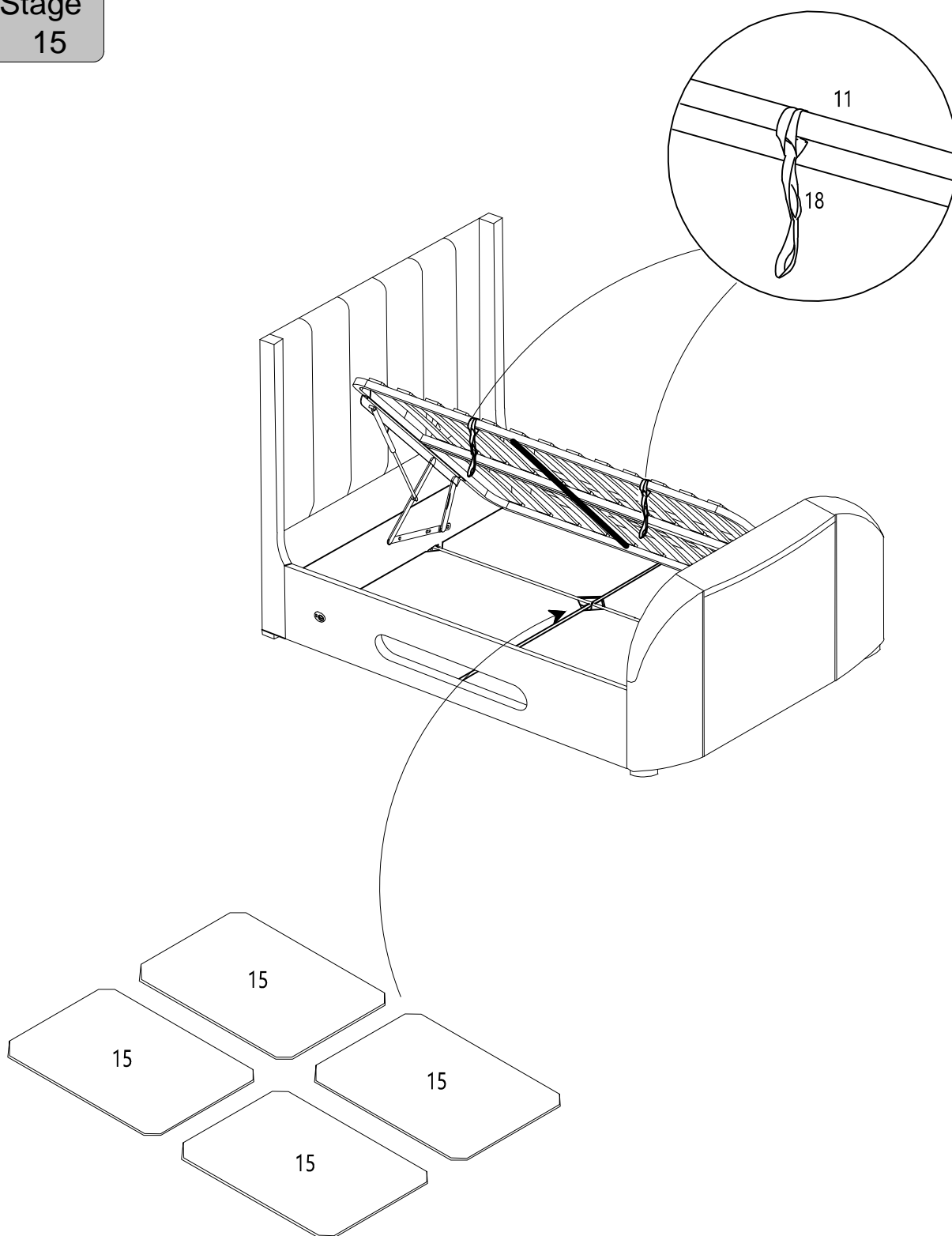

TROUBLESHOOTING.

1. If your TV lift does not operate, please check all power connections at the wall socket and into the base of the footboard.
2. If your TV lift still does not operate, please operate both TV lift buttons to see if one is not operating correctly.
3. If your TV lift still fails to operate, please contact customer service number for further help and information.