

ESSENCE OTTOMAN TV BED

SIZE : 4ft6 & 5ft

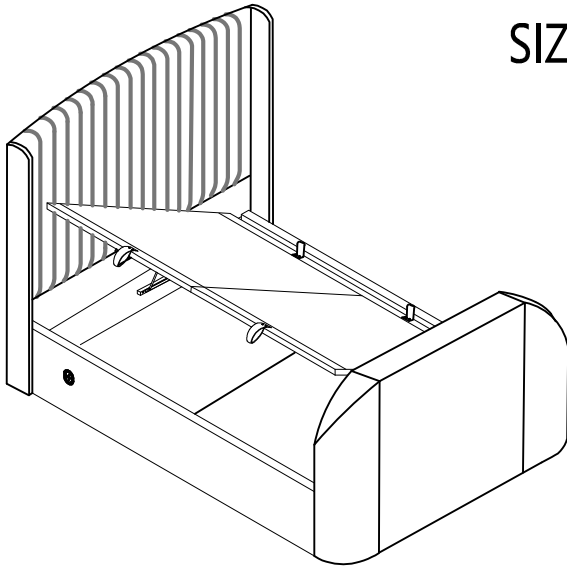

PLEASE READ this sheet prior to assembly to familiarise yourself with the various stages of construction. Carefully open the pack supplied and check the contents against the parts and fittings check list.

Do not destroy any of the packaging until you are certain that you have all the necessary parts for the assembly.

Please ensure that the packaging is disposed of in a safe environmentally friendly way.

CAUTION: There are small components used in the construction of this unit. These loose items should be kept away from young children during assembly, to avoid the danger of choking.

IMPORTANT: BEFORE STARTING TO ASSEMBLE THE BED - PLEASE READ THESE INSTRUCTIONS CAREFULLY



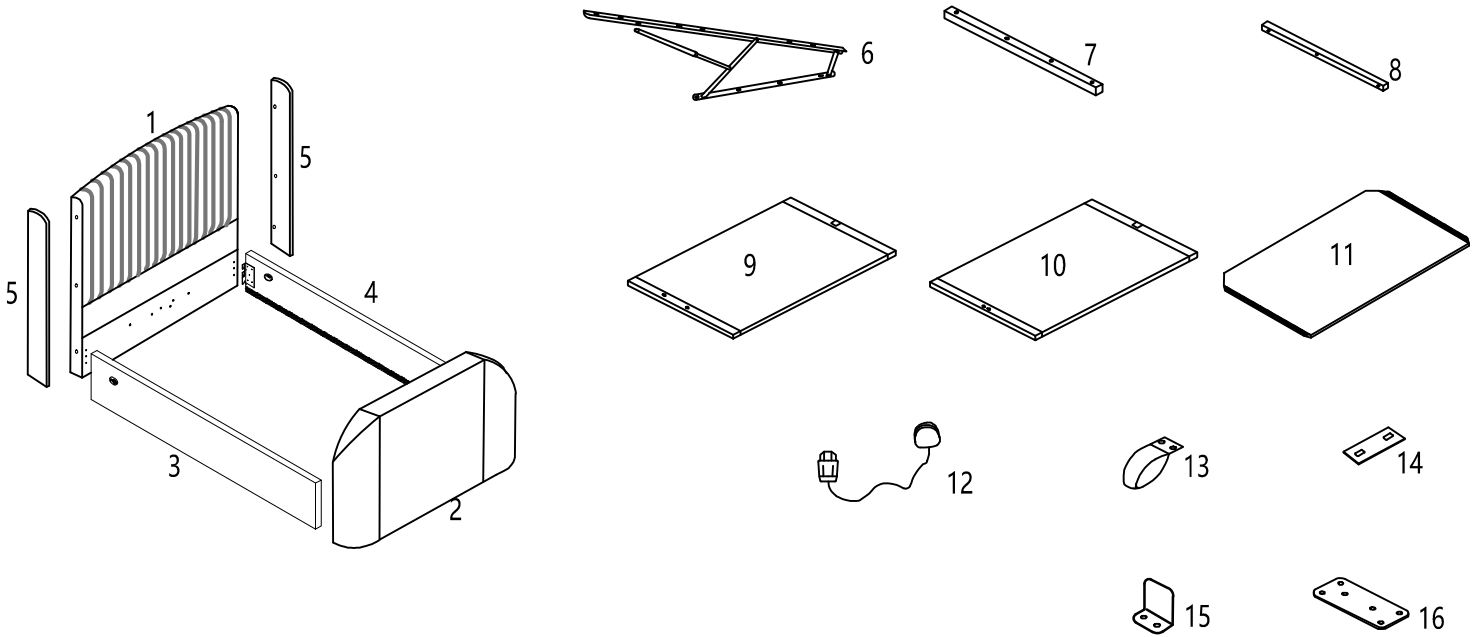

Parts Identification





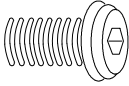
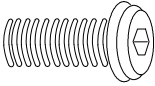
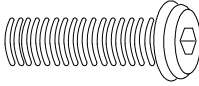

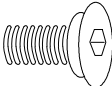

Parts Checklist

Ref.	Description	Qty	Ref.	Description	Qty
1	Headboard	1	10	Board Frame II	1
2	Footboard	1	11	Storage Board	2
3	Side Rail (Left)	1	12	Main Power Lead	1
4	Side Rail (Right)	1	13	Strap	2
5	Headboard Wings	2	14	Metal Plate (for strap)	2
6	Lift Up Mechanism	2	15	Mattress Stopper	2
7	Support Metal Bar	2	16	Metal Plate	1
8	Support Wood	2			
9	Board Frame I	1			

Fittings Checklist

Code	Description	Qty
A	Bolt (M8x30mm) 	x26
B	Bolt (M8x40mm) 	x8
C	Bolt (M8x60mm) 	x8
D	Flat Washer (M8x17mm) 	x12
E	Bolt (M6x15mm) 	x4
F	Bolt (M8x50mm) 	x6

Code	Description	Qty
G	Nut (M8x14mm) 	x6
H	Flat Washer (M8x22mm) 	x6
I	Spanner M14 	x1
J	Allen Key M5 	x1
K	Non-slip Pad 	x18
L	Screw (M4x20mm) 	x6

Additional Tools Required

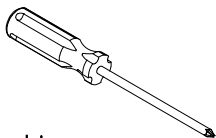

Cross-head Screwdriver

General Hints & TIPS

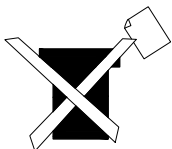

Please retain your assembly instruction and tools provided for future use. Periodically check that all bolts are still tight.

Assembly requires two persons.

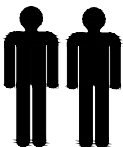

1.5 HOUR

Approximate time to assemble this product

IMPORTANT SAFETY INSTRUCTIONS



WARNING

RISK OF ELECTRIC SHOCK
DO NOT OPEN



CAUTION: TO REDUCE THE RISK OF ELECTRIC SHOCK, DO NOT REMOVE COVER (OR BACK). NO USER - SERVICEABLE PARTS INSIDE. REFER SERVICING TO QUALIFIED SERVICE PERSONNEL.



The lightning flash with arrowhead symbol, within an equilateral triangle, is intended to alert the user to the presence of uninsulated "dangerous voltage" within the product's enclosure that may be of sufficient magnitude to constitute a risk of electric shock to persons.

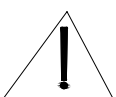

The exclamation point within an equilateral triangle is intended to alert the user to the presence of important operating and maintenance (servicing) instructions in the literature accompanying the appliance.

1. Read these instructions.
2. Keep these instructions.
3. Heed all warnings.
4. Follow all instruction.
5. Do not use this apparatus near water.
6. Clean only with dry cloth.
7. Do not block any ventilation openings. Install in accordance with the manufacturer's instructions
8. Protect the power cord from being walked on or pinched particularly at plugs, convenience receptacles, and the point where it exit from the apparatus
9. Only use attachment / accessories specified by the manufacture.
10. Unplug this apparatus during lightning storms or when unused for long periods of time
11. Refer all servicing to qualifide service personnel. Servicing is required when the apparatus has been damaged in any way, such as does not operate normally.
12. Warning to reduce the risk of electric shock, do not expose this apparatus near moisture.
13. The mains plug is used as the disconnect device, the disconnect device shall remain readily operable.
14. Unplug this apparatus when the apparatus has been damaged, then refer all servicing to Professional.

Assembly

Stage
1

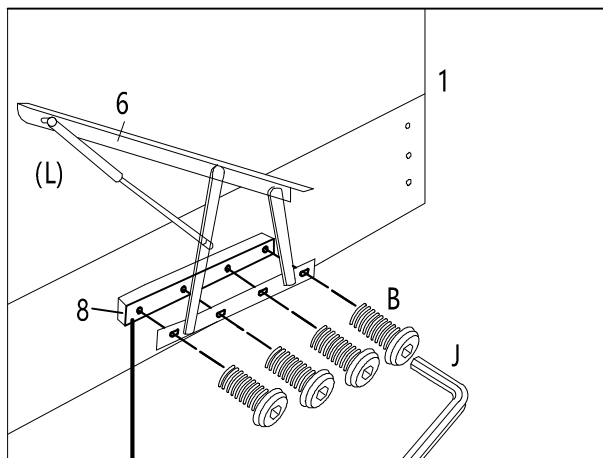
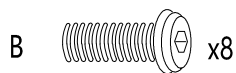

&

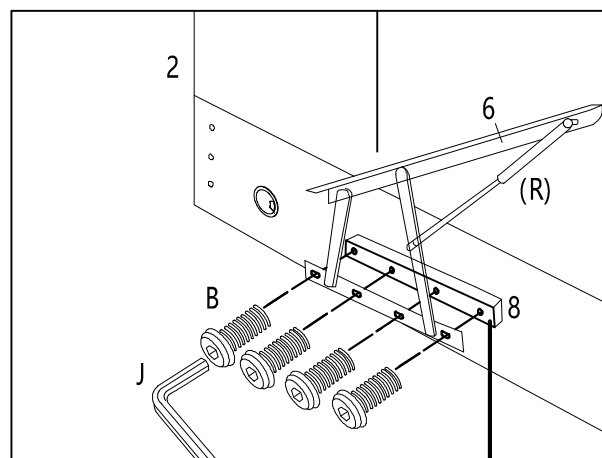

Please note:

When installing the Lift up mechanism (6), the support wood (8) must be installed first

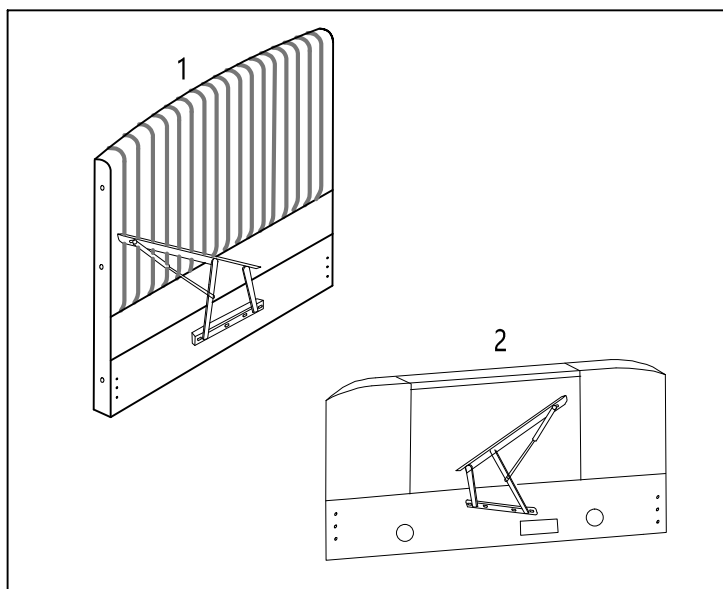

The metal frame base can be chosen to open left or right, and the gas lift mechanism can be installed left or right according to requirements.

Assembly

Stage 2

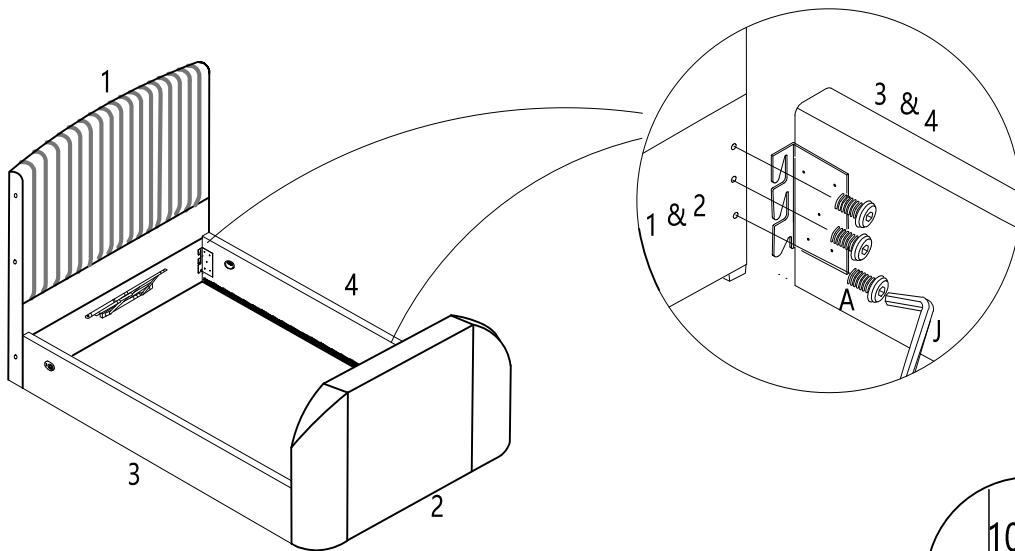

PLEASE DO NOT TIGHTEN ANY BOLTS YET.
Note: Do not tighten fully but leave 10mm protruding as in the diagram.

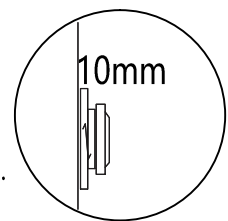

Stage 3

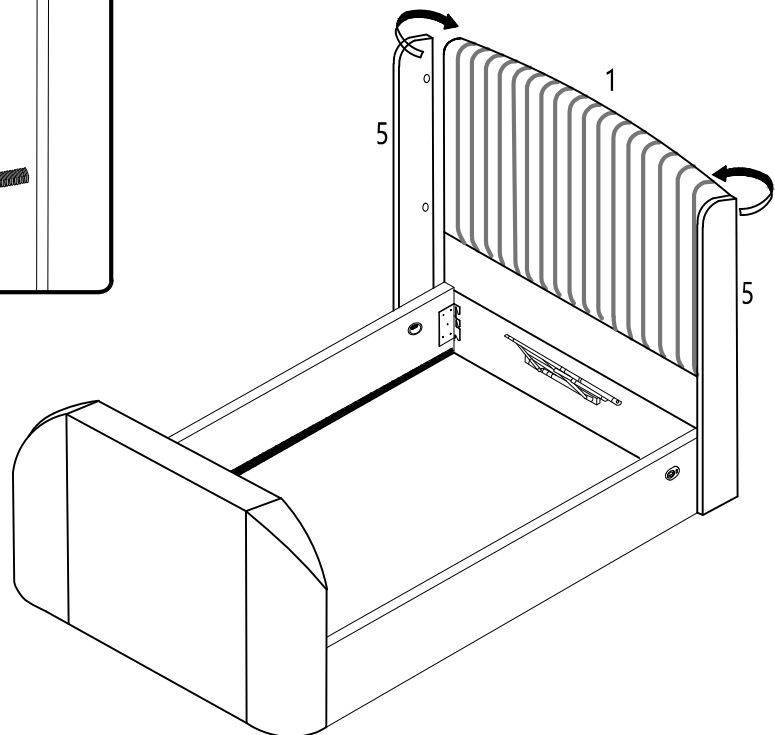
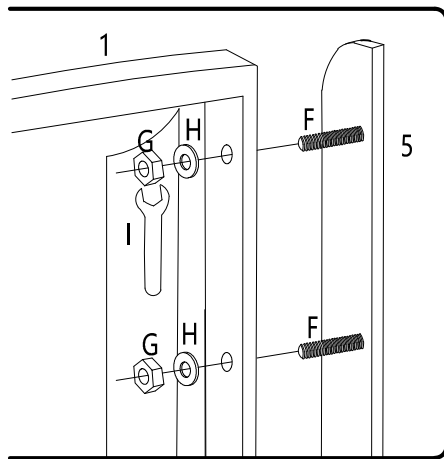
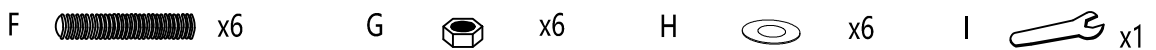

Assembly

Stage 4

Connect the TV lift up Power cord from the control box to the main power supply (extension lead might be needed).

The main power supply must be fully earthed and be easy to reach if you need to disconnect the power.

There is a spare button on the black control box that can be used when the side rail button is unusual.

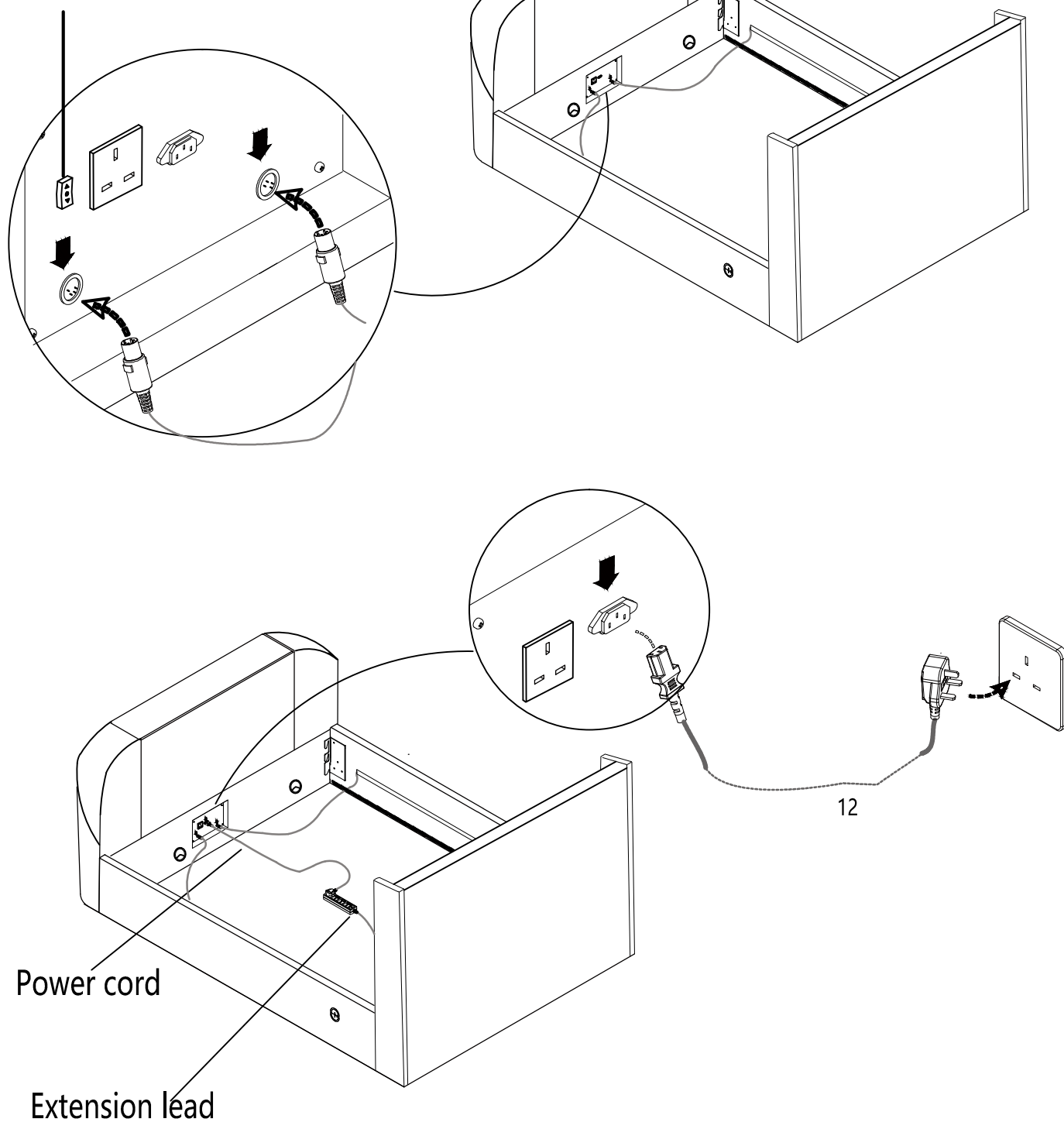

Assembly

Stage
5

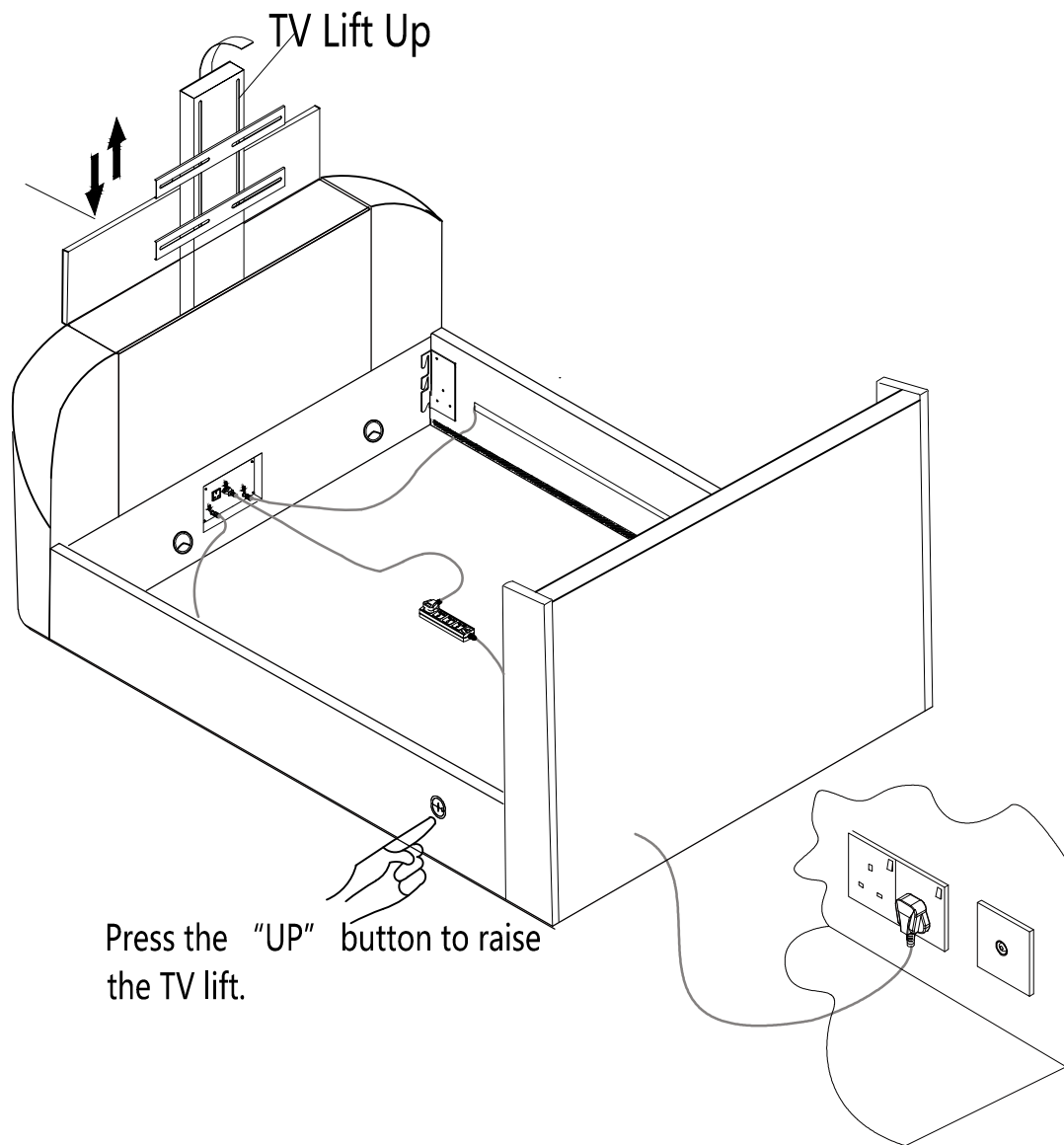

Press the "UP" button to raise the TV lift.

Connect the cables to the television & media equipment make sure the cables are not loose. If necessary use cable ties & cable clips to route cable safely.

When the TV is lowered, power for TV turns off automatically.
When the TV is raised, power turns back on automatically

Assembly

Stage
6

D  x4

E  x4

J  x1

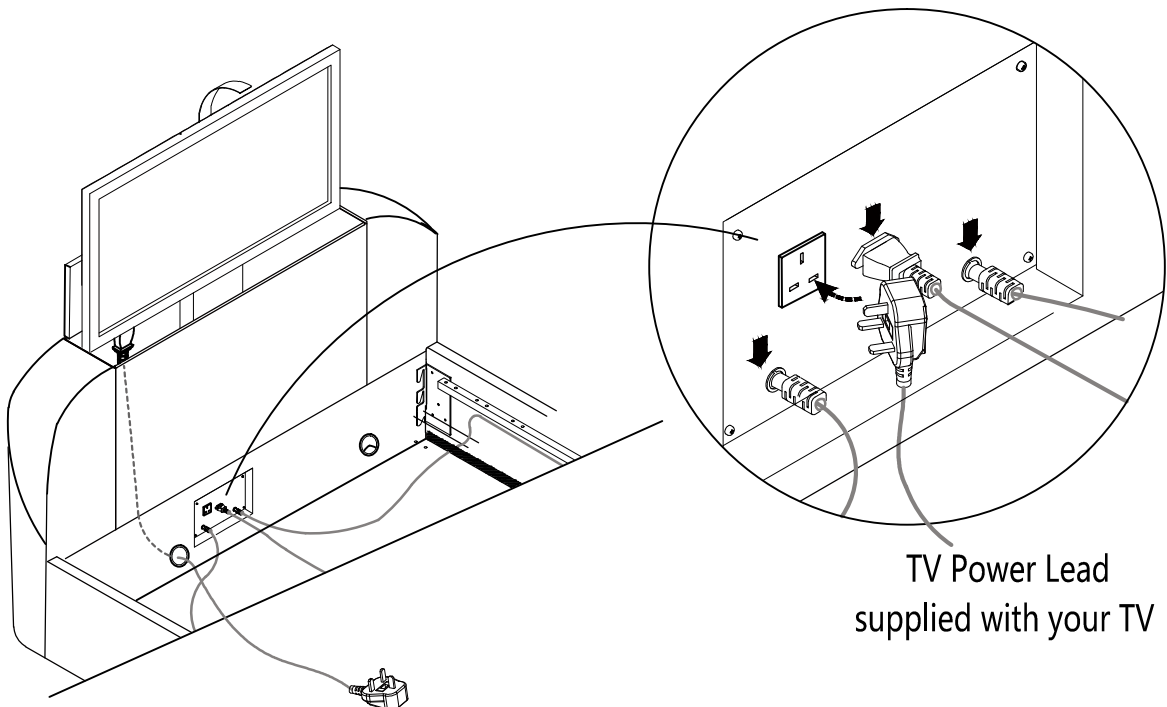
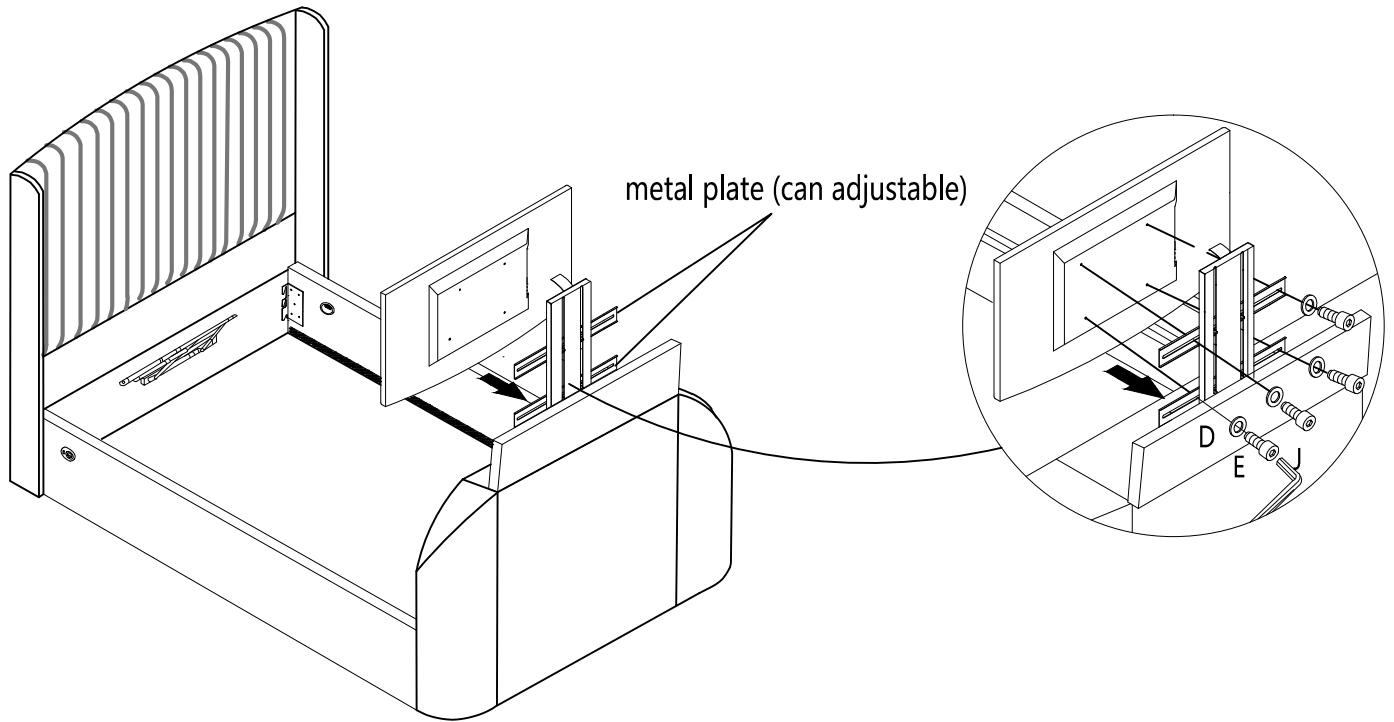

Note: For illustration purposes only, TV connections may vary.

Assembly

Stage
7

A  x8

C  x8

D  x8

J  x1

L  x6

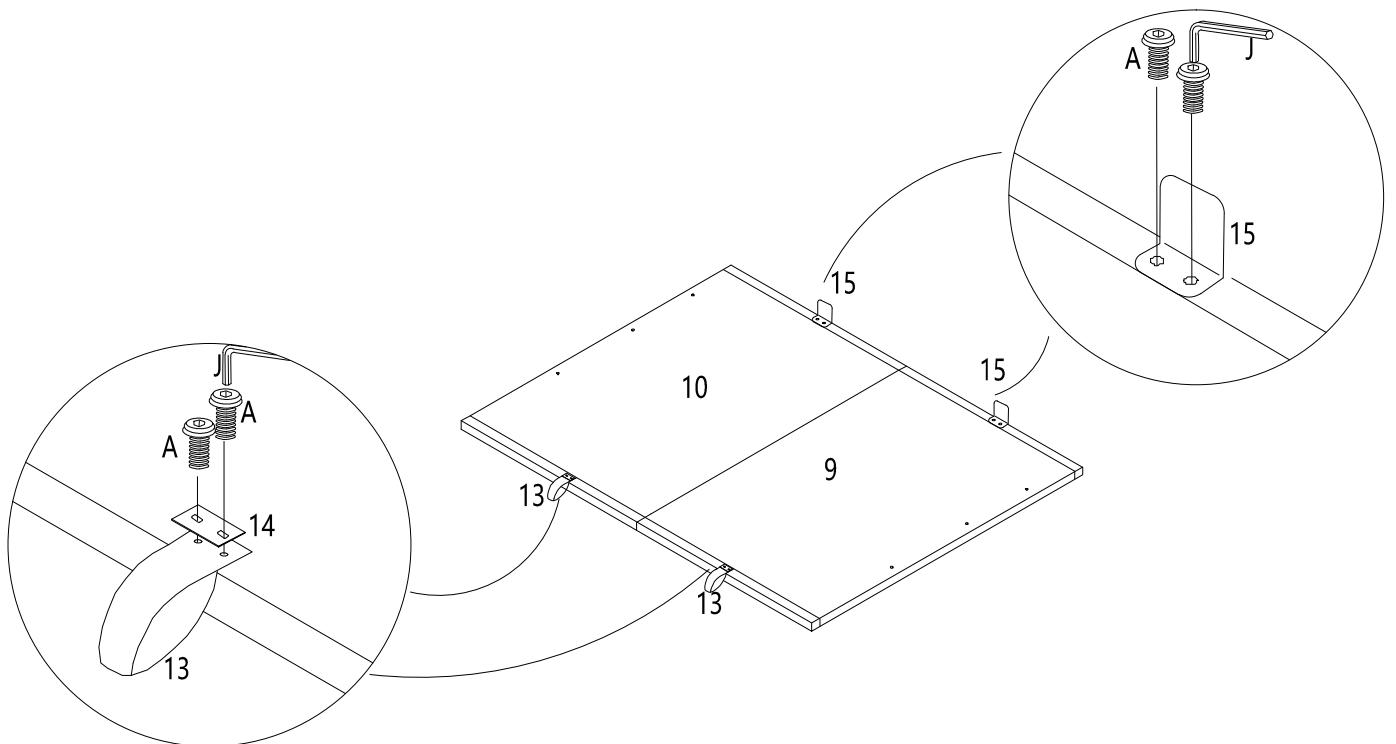
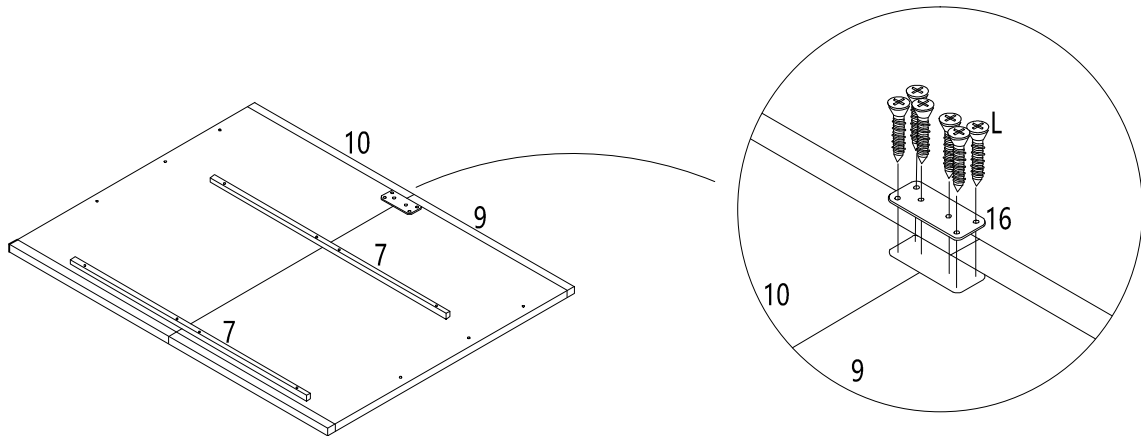
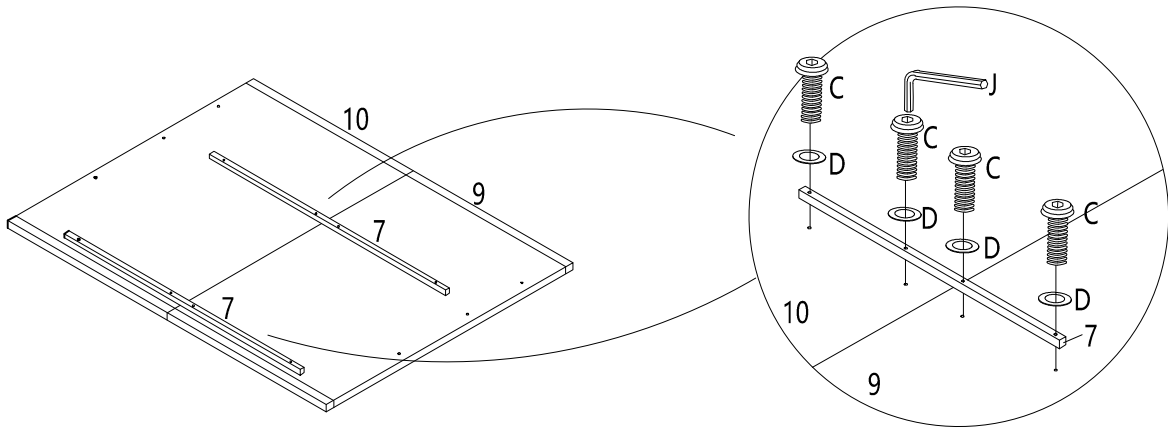

Assembly

Stage
8

A  x6 J  x1

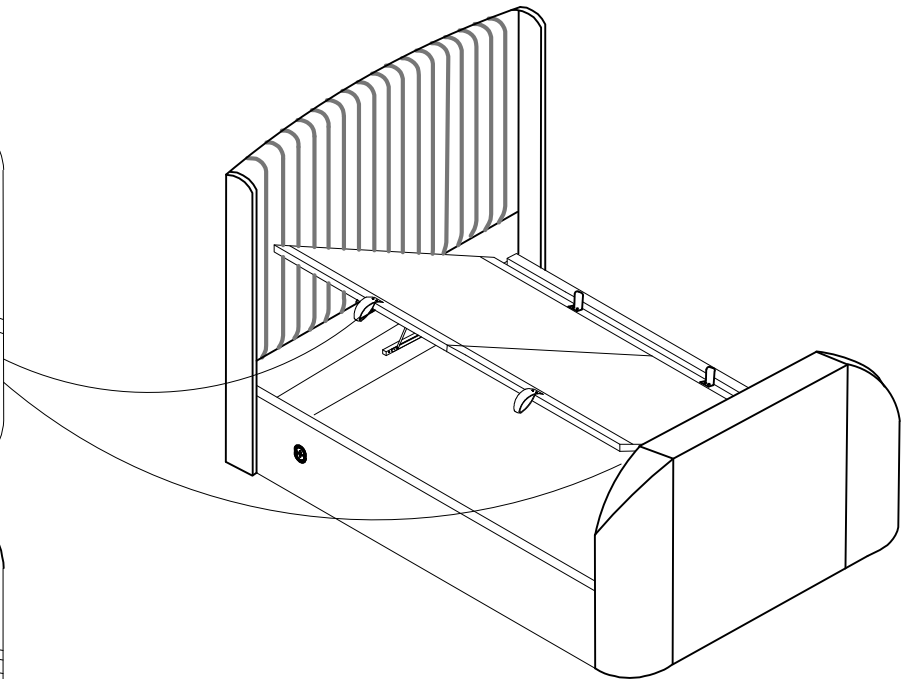
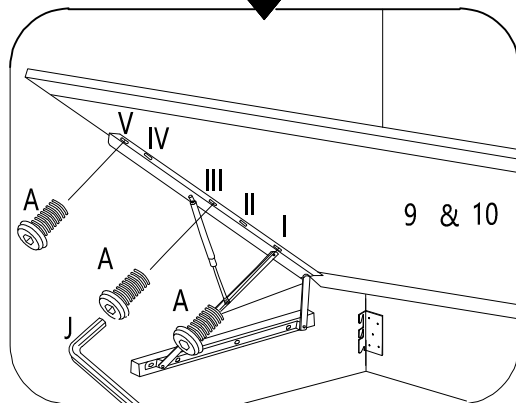
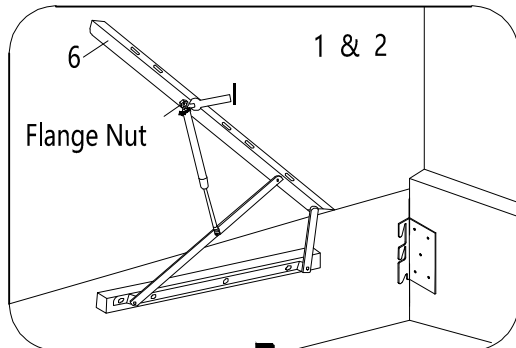

REMARKS: MUST assemble this part in SEQUENCE (I), (II), (III), (IV), (V).

Carefully lay frame down. Make sure there is an even gap each side.
Hold frame then tighten all ten bolt sets 100% using spanner (J) and allen key (I).

Assembly

Stage
9

K  x18

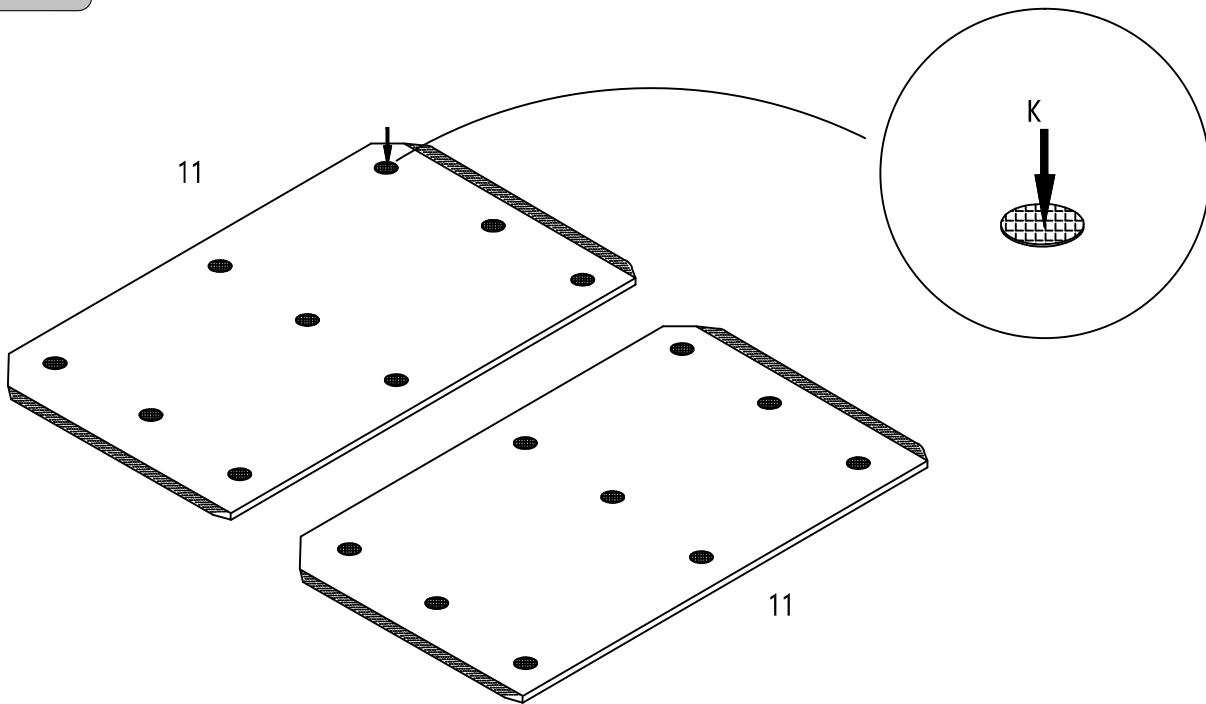

Stage
10

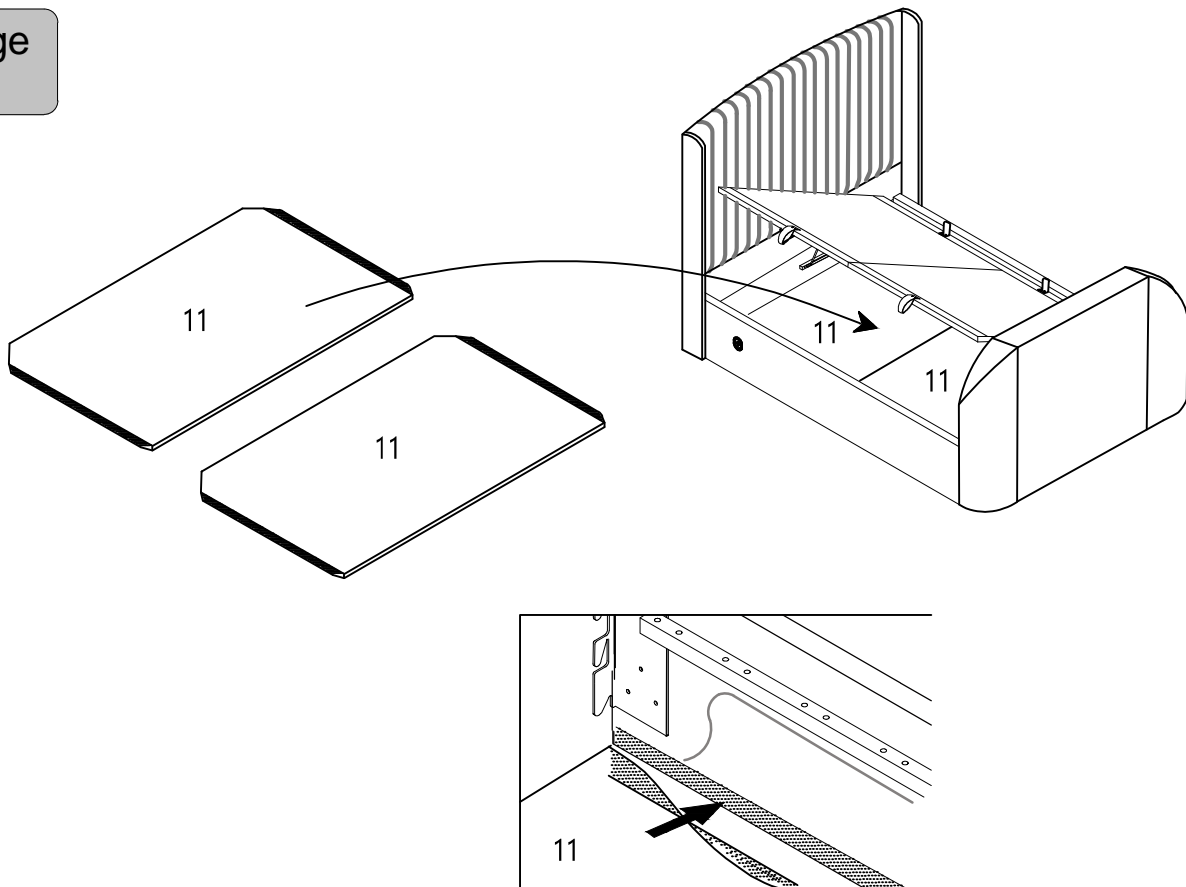

The storage board and side rail need to use Velcro to stick together in order to prevent movement.